

C10 Customizable AC Drive



www.saftronics.com

When flexibility is required in a variety of custom OEM applications the C10 with its Onboard Application Software Area can be modified and tailored to your specified application. The C10 has a robust set of standard features that are ideal for both the industrial and OEM marketplace.

EXPANDED FEATURES

- ▶ Onboard Application Software Area
Customize for your specific machine control
- ▶ 3 Control modes
 - Sensorless Vector
 - V/Hz
 - V/Hz with PG feedback
- ▶ Digital Pulse Train Input (0 to 32 KHz)
- ▶ Simple motor auto tuning for optimum motor performance
- ▶ Maximum output frequency 400 Hz
- ▶ PID Mode with sleep function
- ▶ Graphical LCD operator interface with Copy Function
- ▶ Built-in braking transistor

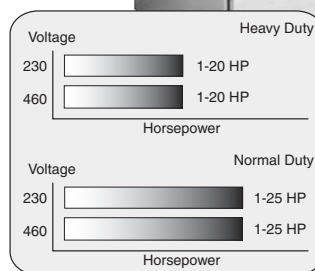

STANDARD FEATURES

- ▶ Dual Ratings
Normal Duty (110% O/L for 1 minute)
Heavy Duty (150% O/L for 1 minute)
- ▶ 3 Programmable analog inputs
- ▶ 2 Programmable analog outputs
- ▶ 8 Digital inputs (sink or source)
- ▶ 2 or 3 Wire control
- ▶ 3 Digital outputs
- ▶ 16 Preset speeds
- ▶ Speed Search
- ▶ RS-485 Modbus RTU
- ▶ Energy savings
- ▶ DC Injection braking
- ▶ Over/under torque detection 2 levels
- ▶ 2.5 - 15 KHz carrier frequency
- ▶ Power loss ride-thru
- ▶ 33 Monitoring functions
- ▶ Fault History (up to 4)

C10 Keypad

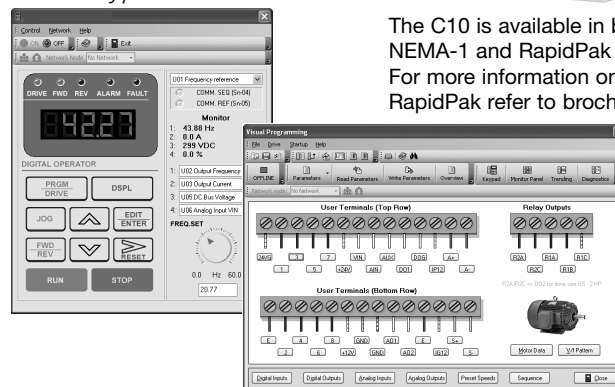

The C10 is available in both standard NEMA-1 and RapidPak configurations. For more information on Safronics RapidPak refer to brochure 027-2043.

C10 Visual Programming



SAFLINK™ is an innovative tool designed for easier programming and trouble-shooting of Safronics drives. Please visit our Web site at www.saftronics.com and try out a demo version.



Standard Specifications

Environmental Condition

Enclosures	NEMA 1
Installation Location: NEMA 1	Intended for indoor use only, less than 1000 meters (3300 feet) elevation, not in contact with corrosive gas, oil mist, dust or direct sunlight.
Stored Temperature	-25°C to +60°C (-13° to +140°F)
Ambient Temperature	-10°C to +40°C (+14 to 104°F)
Humidity	Below 90% RH (non-condensing)
Vibration	5.9 m/s ² (0.66)
Cooling Method	1 Hp and above – Fan-cooled

Output

Rated Output Voltage	230 VAC, 3-Phase, 200V - 230V 480 VAC, 3-Phase, 380V - 480V
Frequency Range	0.0 to 400 Hz
Overload Current Rating	150% of drive's rated current for 1 min. (HD)

Power Supply

Rated Input AC Voltage	230 VAC: 200 to 230 VAC 50/60 Hz, 3 phase (1 to 20 Hp) 460 VAC: 380 to 480 VAC 50/60 Hz, 3 phase (1 to 20 Hp) Voltage: +10%, -15%; Voltage Unbalance - Within 3% Frequency: +/-5%
Control System	Sinusoidal PWM Control (V/Hz control, Sensorless Vector)
Momentary Voltage Dip	230 VAC: When the input voltage is 165 VAC or more, the drive can be operated continuously. 460 VAC: When the input voltage is 310 VAC or more, the drive can be operated continuously. When the input voltage drops below 165/310 VAC from rated voltage, the drive can be operated for 15ms. The smooth recovery method is selectable.

Control

Starting Torque	V/F mode 150% at 3Hz / sensorless vector mode 150% at 1 Hz
Carrier Frequency	2.5-15 kHz
Frequency Command Resolution	Analog Command 0.06Hz / 60Hz Digital: 0.01 Hz
Output Frequency Accuracy (Stability)	Analog setting: ±0.1% or less of max. frequency @ 25°C ± 10°C Digital setting: ±0.01% or less of max. frequency (-10°C to +40°C)
Voltage/Frequency Characteristics (V/F)	15 preset V/F curve and a custom

Torque Boost	Auto: setting for optimum control corresponding to the load torque
Acceleration/Deceleration Characteristics	0.01 to 6000 seconds (Four acceleration/deceleration time settings are possible independent of each other by selecting digital input signals)
2 Analog Outputs	Scale calibration of externally connected analog meter (10 VDC, 0-200% gain setting)
Pattern Operation	16 independent stages (frequency up to 400 Hz, duration up to 6000 seconds each). Configuration: Single cycle Single cycle with continuous last setting speed
Momentary Power Loss Ride Thru	longer than 1 ms, stop otherwise
High/Low Limiter	Output frequency upper and lower range limit 0 to 100%
Bias	Magnitude of the zero offset can be set from -100% to +100%
Gain	Output frequency gain corresponding to the reference signal can be set from 0.0 to 1000%
Programmable Jump Frequency	Three selectable frequencies can be set to avoid a mechanical resonant point. Width is adjustable from 0 to 25.5 Hz (1 Hz steps.)
Slip Compensation Control	Maintains motor at constant speed with load fluctuations.
Torque Limit Control	Output torque can be controlled within a range of 30% to 200% (1% steps.)
16 Step Preset Speed	16 programmable preset speeds selectable by 4 contact closures.
PID	Normal or Inverse operation can be selected.
Momentary or Maintained Operation	Selection between the maintained contact operation/stop command (2-wire operation) or the momentary contact (3-wire operation).
Terminal Function Change	Multi-Use terminals changed via Function Code settings. Terminal 1 to 8 inputs; DO1 and DO2 transistor output and Form C relay output.
Sensorless Vector Control	Improves torque characteristics throughout the speed range and improves speed regulation.

Operation

Frequency Reference Signal	Speed potentiometer: 0 to +10 VDC, 10 to 0 VDC 4 to 20 mA, 20 to 4mA
Digital Input Signals	Multi-step frequency selection (1 to 16 steps) Acceleration and deceleration time selection (2 step) 3-Wire operation mode Coast-to-Stop command Alarm Reset External Fault (NO/NC) Forward Jog / Reverse Jog (one button operation)

DC injection brake command
UP command (UP)
DOWN command (DOWN)
PID control cancellation
External base block (NC/NO)
Link operation selection (Standard: RS485)
Inverter overheat warning
Multi-function analog input enable
Timer input
Speed search 1 and 2

Digital Output Signals

One programmable Form C output contact rated 250 VAC, 1.0 Amp.
One programmable auxiliary relay contact rated 250 VAC, 1.0 Amp
One open collector output rated 48 VDC, 50 mA from external power. Two relay and one open collector outputs can be configured to provide one of the following functions:

- Running
- Zero speed
- Frequency agree
- Setting frequency agree
- Frequency detection 1 and 2
- Inverter ready
- Undervoltage detected
- Base block active
- Keypad Run mode
- Keypad Reference mode
- Overtorque detected
- Fault
- Undervoltage Alarm
- Inverter overheat
- Motor overload
- Inverter overload
- Faulty retry
- Timer output
- RS-485 communication
- RS-485 communication fault

Protective Functions

- Overcurrent	- Inverter Overload
- Ground Fault	- Memory Faults
- Overvoltage	- Keypad Panel Communication Error
- Undervoltage	- EEPROM Fault
- Overheating of Heatsink	- MODBUS RTU Fault
- External Alarm	- Overtorque
- Overheating Internally	- PG Overspeed
- Overheating of Braking Resistor	- PG Open
- Motor 1 Overload	- Overspeed deviation

Keypad Features

Graphic LCD Panel (2-line 20 characters) English

- | | |
|----------------|---|
| Keypad Display | <ul style="list-style-type: none"> - Output frequency - Output Amps (A) - Output Volts (V) - DC Bus Voltage (VDC) - Analog input values (%) - Input terminal status - Output terminal status |
|----------------|---|

- | | |
|--|--|
| MODBUS RS485 RTU
Serial Communication | <ul style="list-style-type: none"> - Physical Level: EIA/RS485 - Transmission Distance: 500m max. - Number of nodes: 32 total - Transmission Speed: 1,200, 9,600, 4,800, 2,400 (bits/s) - Transmission mode: Half duplex - Transmission protocol: MODBUS RTU - Character code: Binary - Character length: 8 bits - Error check: CRC - Speed feedback (%) - Speed compensation (%) - PID input (%) - PID output (%) - Motor speed (RPM) |
|--|--|

Charge Lamp (LED)	Lights when DC Link capacitor voltage is present.
-------------------	---

Mounting Clearance

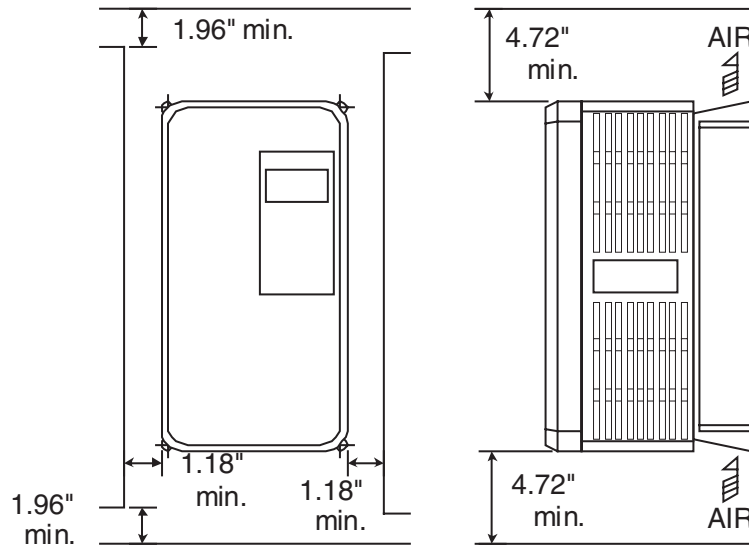

Dimensions 1 - 2 HP

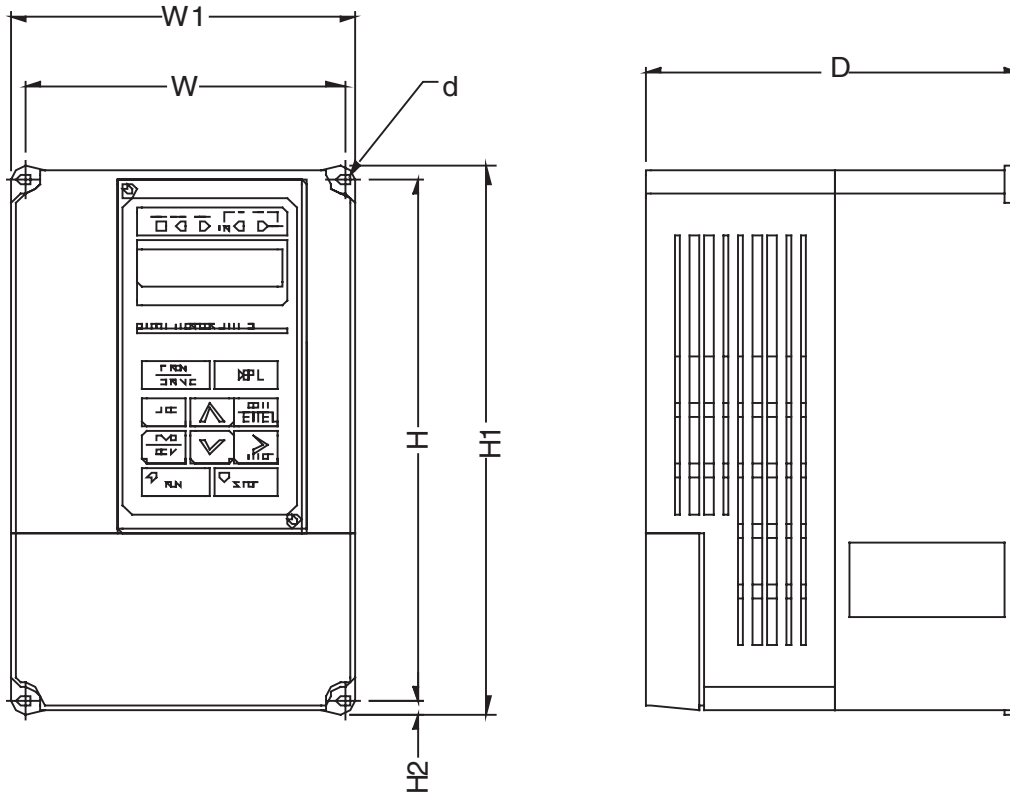

VOLTAGE	HP	MOUNTING DIMENSION (inches)				EXTERNAL DIMENSION (inches)			WEIGHT (lbs.)
		W	H	H2	D	W1	H1	D	
230 V 1Ø / 3Ø	1	4.80	8.15	0.19	M5	5.20	8.54	5.65	5.07
	2								
460 V 3Ø	1	4.80	8.15	0.19	M5	5.20	8.54	5.65	5.07
	2								

Dimensions 3 - 10 HP

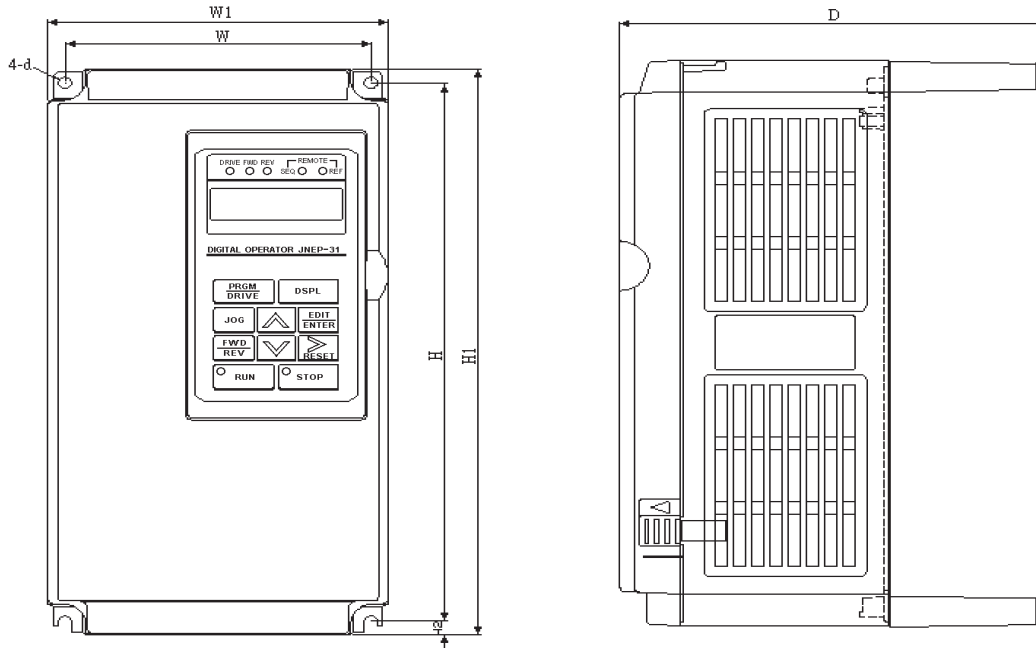

VOLTAGE	HP	MOUNTING DIMENSION (inches)				EXTERNAL DIMENSION (inches)			WEIGHT (lbs.)
		W	H	H2	D	W1	H1	D	
230 V 1Ø / 3Ø	3	4.96	10.47	0.27	M6	5.51	11.00	6.95	8.60
	5.0								
	7.5								
230 V 3Ø	10	7.56	11.26	0.28	M6	8.31	11.81	8.46	12.34
	3								
	5.0								
	7.5								
460 V 3Ø	10	7.56	11.26	0.28	M6	8.31	11.81	8.46	12.34
	3								
	5.0								
	7.5								

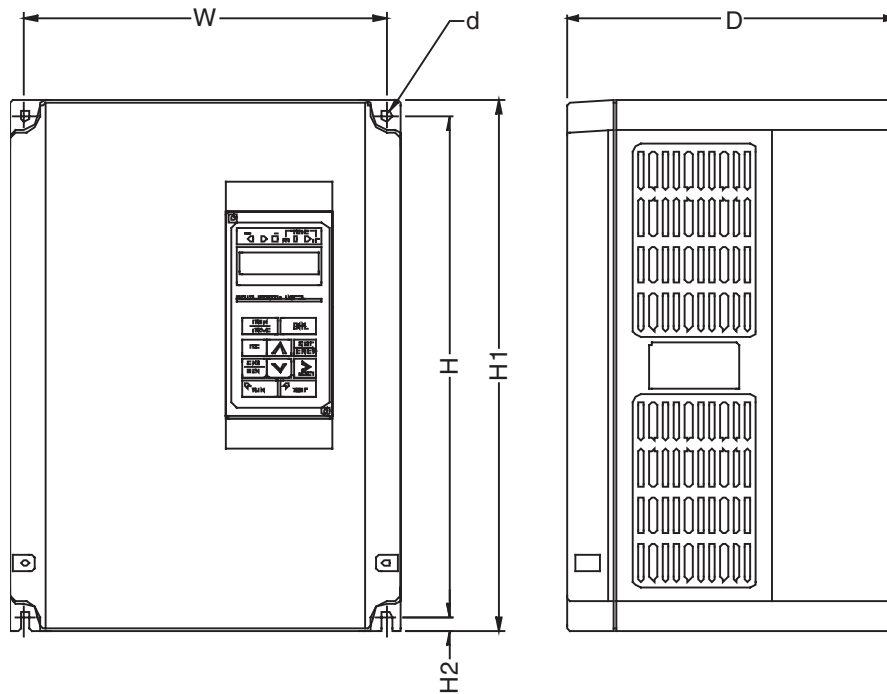

Dimensions 15 - 20 HP

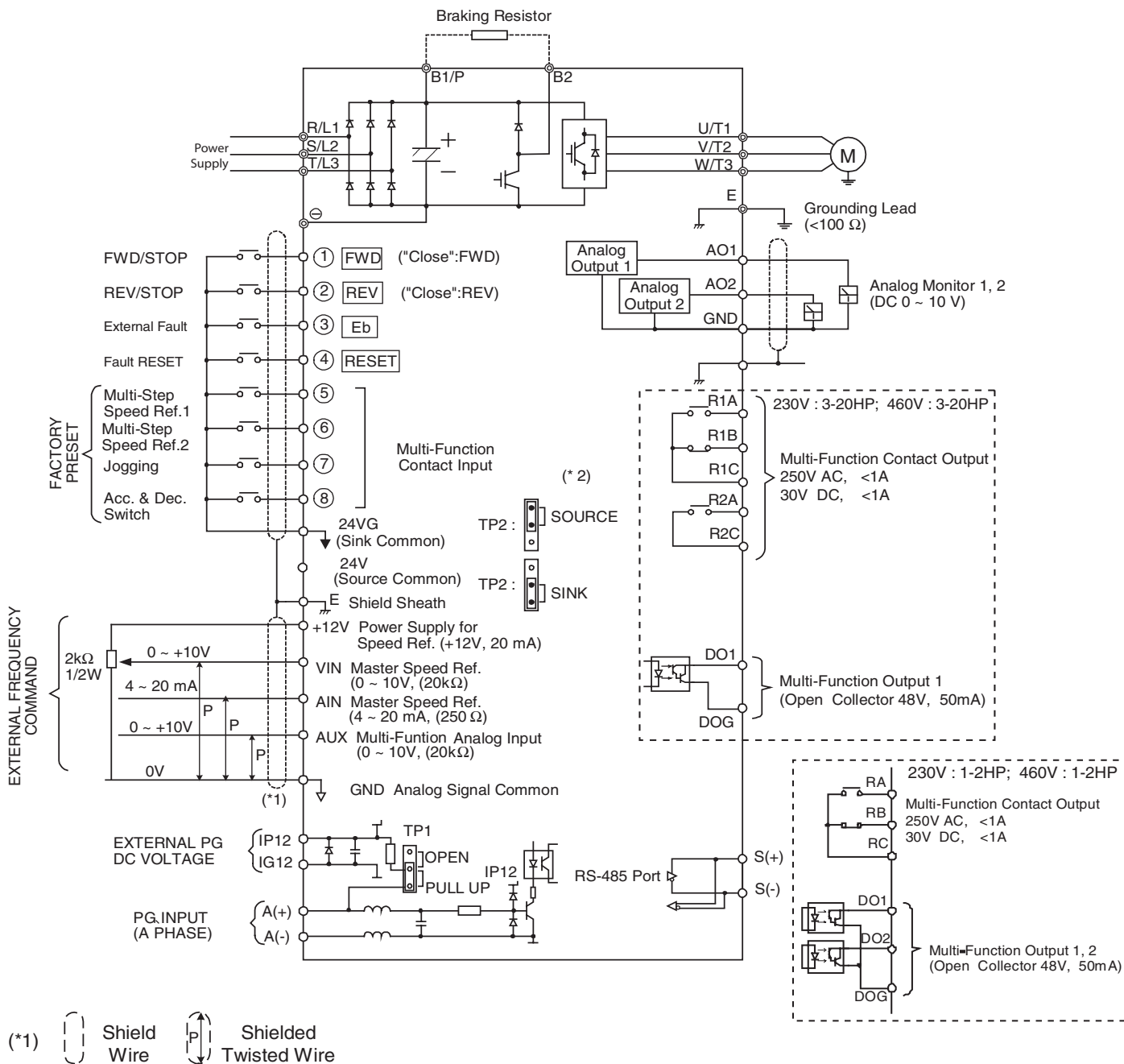

VOLTAGE	HP	MOUNTING DIMENSION (inches)				EXTERNAL DIMENSION (inches)			WEIGHT (lbs)
		W	H	H2	D	W1	H1	D	
230 V 3Ø	15	9.65	13.39	0.39	M6	10.43	14.17	8.86	26.46
	20								
460 V 3Ø	15	9.65	13.39	0.39	M6	10.43	14.17	8.86	26.46
	20								

Wiring Diagram 230V : 3-20HP, 460V : 3-20HP



(*1)  Shield Wire  Shielded Twisted Wire

(*2) Terminals ① ~ ⑧ can be set as SINK or SOURCE type input interface. When setting terminal as sink type input, the short jumper of TP2 must be set to SINK position. Set to SOURCE position for source type input.

(*3) The Terminal Arrangement

24VG	1	3	5	7	24V	VIN	AIN	AUX	DO1	DOG	IP12	A(+)	A(-)
	E	2	4	6	+12V	GND	GND	AO1	AO2	E	IG12	S(+)	S(-)

R2A	R2C	R1A	R1B	R1C
-----	-----	-----	-----	-----

(*4) The Control Board Code No. : 4P101C0060002