



**www.saftronics.com**

## **VG5 and VG5+ PG-X2 ENCODER INTERFACE CARD KIT**

### **TABLE OF CONTENTS**

	<b>PAGE</b>
SAFETY FIRST!	2
WARNING	2
DESCRIPTION	3
SPECIFICATION	3
KIT INCLUDES	3
INSTALLATION PROCEDURE	4
WIRING RECOMMENDATIONS	6
ENCODER SELECTION	6
ENCODER PARAMETER SETTINGS	7

**Saftronics, Inc.**

5580 Enterprise Pkwy., Ft. Myers, FL 33905

Telephone: (941) 693-7200

Fax: (941) 693-2431

P/N 027-2303

Card Number E001063-28

---

---

## **SAFETY FIRST !**

PLEASE READ THIS INSTRUCTION MANUAL THOROUGHLY BEFORE ATTEMPTING ANY INSTALLATION, OPERATION, MAINTENANCE OR INSPECTION. FAILURE TO FOLLOW THE RECOMMENDED PROCEDURES OR CAUTIONS IN THIS MANUAL COULD RESULT IN INJURY TO PERSONNEL AND/OR DAMAGE TO EQUIPMENT.

### **CAUTION !**

1. CHECK THE NAME WRITTEN ON THE PRODUCTS AND INSURE THAT THE PROPER PART HAS BEEN RECEIVED.
2. INSPECT THE PART FOR ANY DAMAGE DUE TO SHIPMENT.
3. THE OPTION CARD USES CMOS IC CHIPS AND CAN BE DAMAGED BY STATIC ELECTRICITY.
4. BEFORE INSTALLING THE OPTION CARD, TURN OFF ALL POWER TO THE EQUIPMENT AND INSURE THE CHARGE INDICATOR LAMP ON THE INVERTER IS OFF. LETHAL VOLTAGES ARE PRESENT !
5. DO NOT CONNECT OR DISCONNECT WIRING WHILE POWER IS ON !
6. FOLLOW GOOD STANDARD WIRING PRACTICES AND ANY APPLICABLE CODES THAT MAY APPLY.

### **WARNING!**

*Saftronics* manufactures component parts that can be used in a wide variety of industrial applications. The selection and application of *Saftronics* products remains the responsibility of the equipment designer or end user. *Saftronics* accepts no responsibility for how it's products may be incorporated into the final design.

Under no circumstances should any *Saftronics* product be incorporated into any product or design as the exclusive or sole safety control. Without exception, all controls should be designed to dynamically fault detect and fail safe under all circumstances. All products designed to incorporate a component part manufactured by *Saftronics*, must be supplied to the end user with appropriate warnings and instructions as to the safe use and operation. Any warnings provided by *Saftronics* must be passed through to the end user.

*Saftronics* offers an express warranty only as to the quality of it's products to conform to the catalog specifications. NO OTHER WARRANTY EXPRESS OR IMPLIED ARE OFFERED. *Saftronics* assumes no liability for any personal injury, property damage, losses or claims, arising out of the mis-application of it's products.

## Description

In order to provide speed feedback to control and minimize motor speed changes due to slip, the **PG-X2** card, designed for use with the **VG5** and **VG5+** series of inverters, provides an interface between the motor (incremental) encoder and the inverter control circuitry to facilitate feedback control. The **PG-X2** accepts a two phase input A and B (quadrature) for motor directional detection, and a marker pulse, Z input (one pulse per revolution). The **PG-X2** also provides A, B, and Z outputs for monitoring or control and a 5 Vdc / 12 Vdc @ 200 mA max. supply to power the encoder. The card can be used with the inverter in the V/F or Flux Vector modes (see Table 1, and also refer to the VG5 or VG5+ programming manual, part number).

## Specification

- 1 - A, B, & Z inputs - differential RS-422 compatible
- 2 - Input Frequency Range - 50 Hz to 300 kHz
- 3 - A, B, & Z outputs - differential RS-422 Compatible
- 4 - Encoder Power Supply - 5 Vdc or 12 Vdc @ 200 mA max. (see Notes)

### **Notes:**

- a. Either the 5 Vdc or the 12 Vdc supply may be used; both **cannot** be used simultaneously.
- b. The maximum current available from either supply is 200 mA. If the encoder requirements exceed this, then an external supply must be provided (see FIGURE 6).

## Kit Includes

- (1) PG-X2 Encoder Interface Card (Figure 1)
- (2) SRNT41028-9 Mounting Spacer (Figure 2)

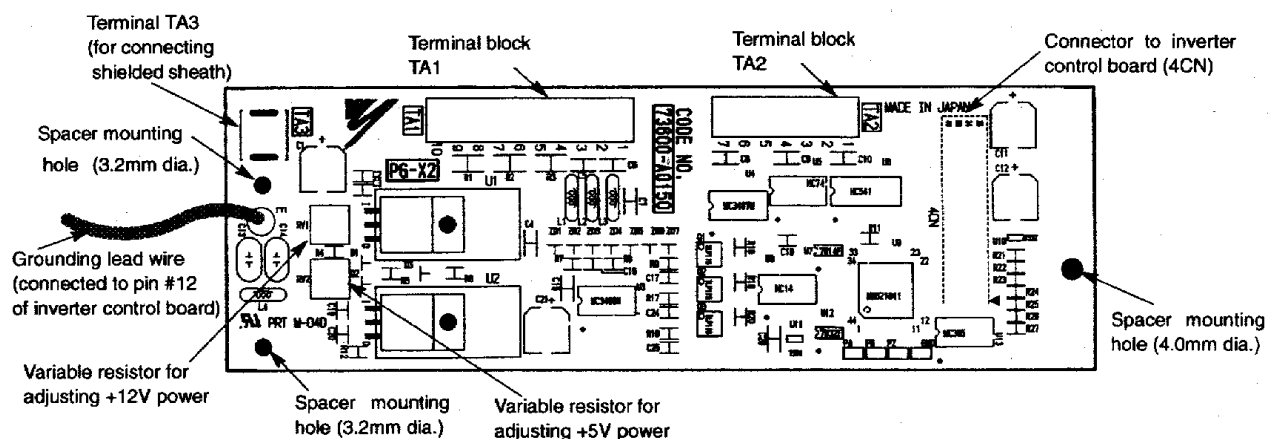
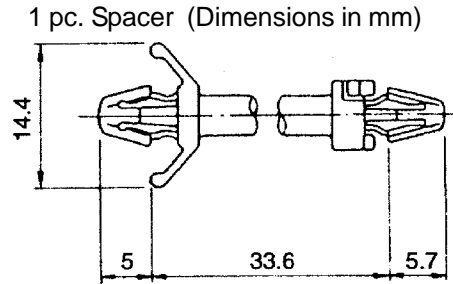

FIGURE 1: Encoder Interface Card

Verify that the attachment below is in the package:

FIGURE 2: Spacer (Code No. SRNT41028-9)



**Installation Procedure**

- (1) Turn OFF the main power to the inverter and wait for the time specified on the cover of the inverter. Remove the cover and verify that the CHARGE indicator lamp is OFF.
- (2) Insert the attached spacer (SRNT41028-9) into the spacer mounting hole in the mounting base of the inverter (see FIGURE 3).

Inverters of 3.7 kW or smaller capacities have two closely placed holes. Insert the spacer into the hole on the 7CN side. Inserting into the wrong hole will stack the spacer. Be careful to insert in the proper hole in the proper inserting direction.

- (3) Align the two holes of PG-X2 and projections as shown in the detailed side view, first at location (a) and then at (b), and precisely place the card on the option A connector. Insert the spacer mounted at (2) above into the PG-X2 spacer mounting hole (see Part A of the side view).

Verify that 4CN is precisely aligned to PG-X2. Gently push the card until it clicks.

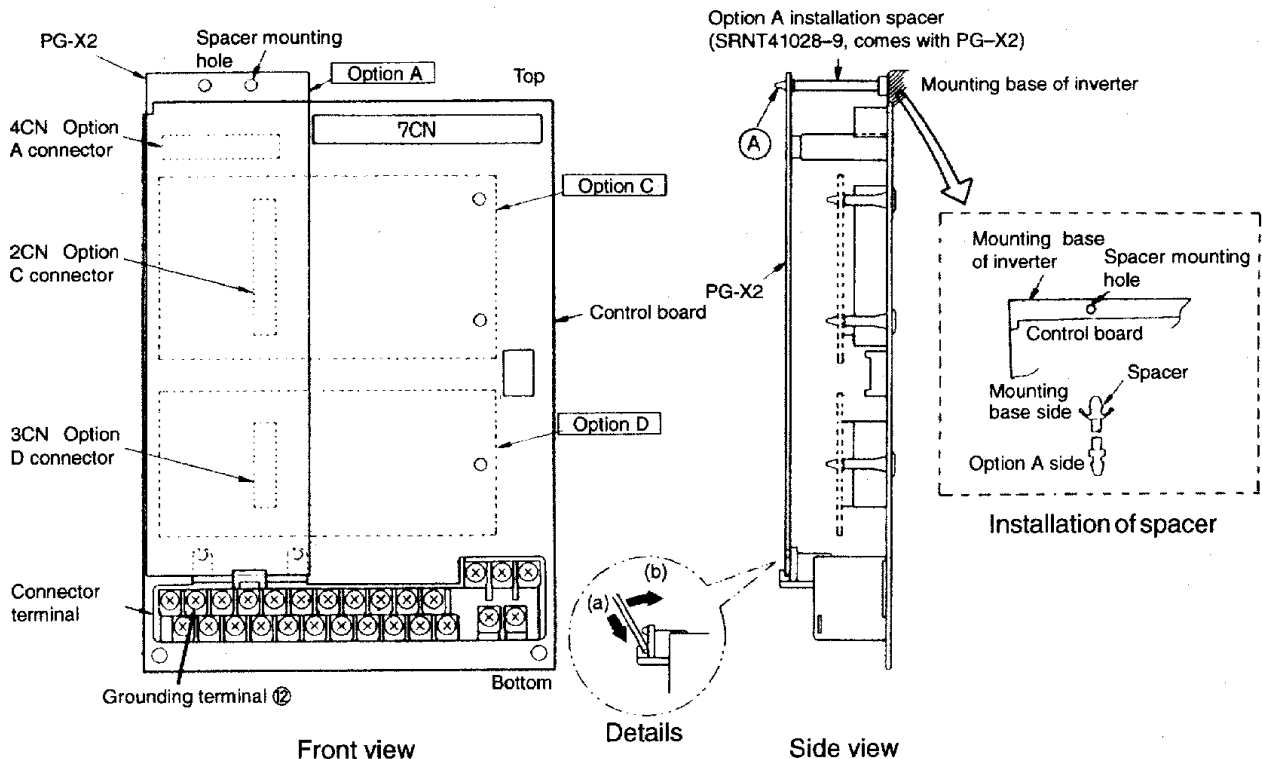
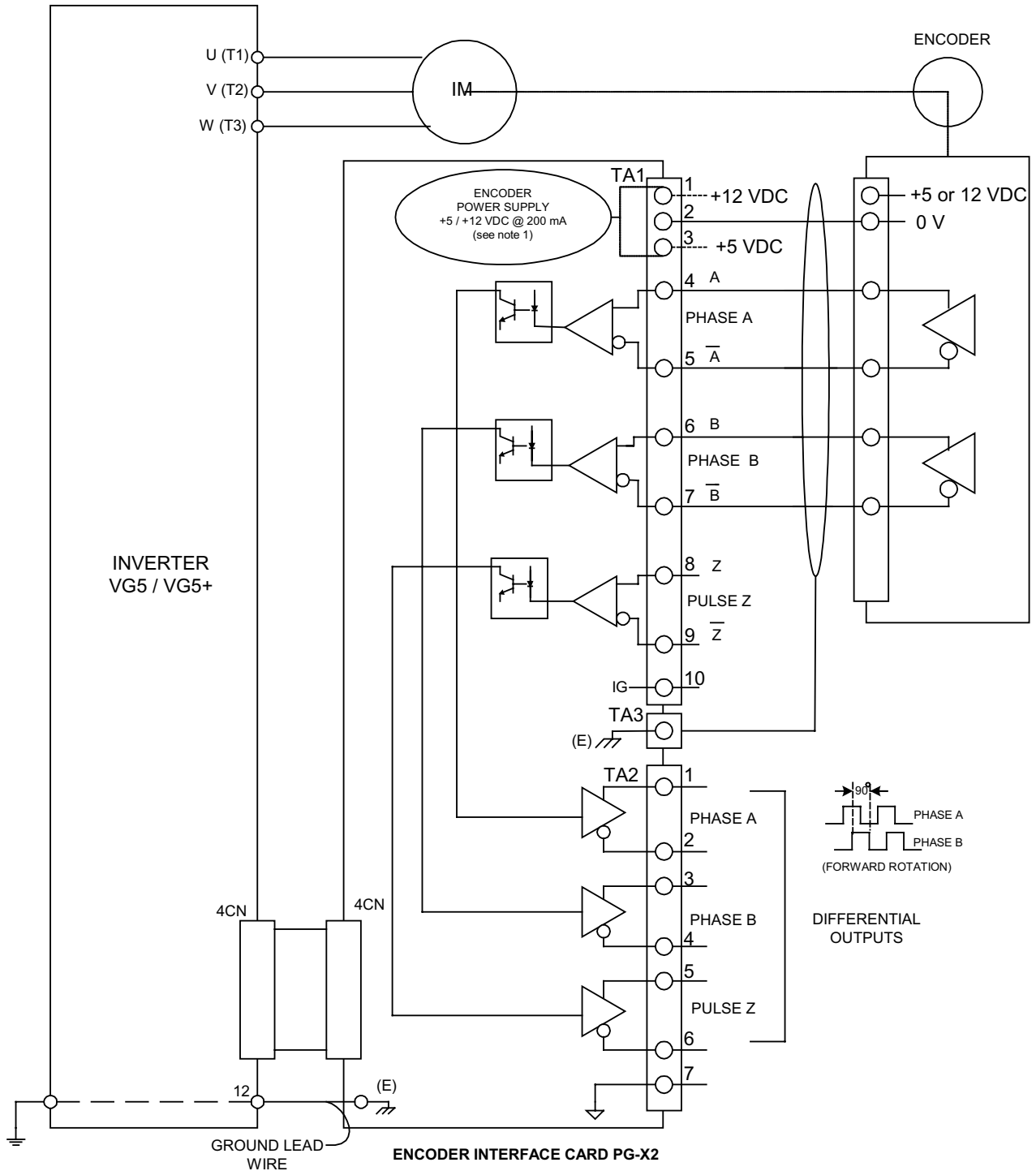

FIGURE 3: Installation of Encoder Interface Card PG-X2



Notes: 1- TA1 1-2 (0v) : +12 VDC @ 200 mA max.  
TA1 3-2 (0v) : + 5 VDC @ 200 mA max.  
**Do not use both supplies at the same time.**  
If the encoder requires more than 200 mA,  
then an external supply must be used (see  
Fig.6)

FIGURE 4: Interconnection Diagram

**Wiring Recommendations**

- (1) All signal wiring (from terminals TA1 and TA2) of the PG-X2 card should be run separately from any power wiring or cable.
- (2) Use shielded twisted cable between the PG-X2 card and the encoder, and ground the shield properly as shown in FIGURE 5. Good shield grounding practices will help minimize any noise problems. Also, the cable length should not exceed 160 ft. (50 m).

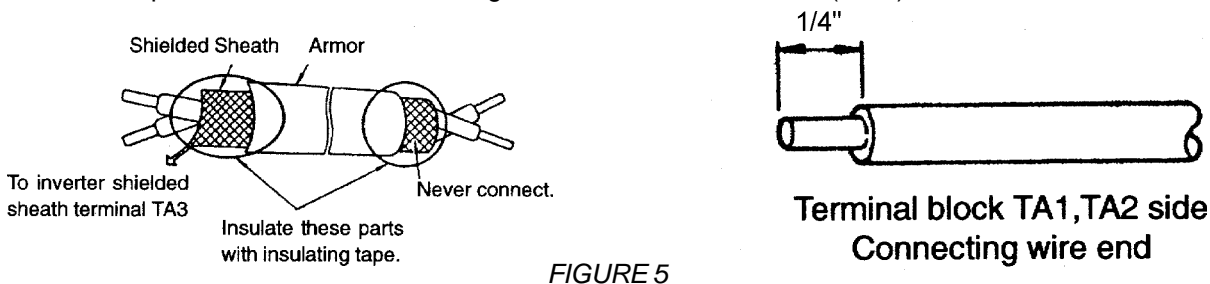

FIGURE 5

- (3) Applicable wire sizes for terminal blocks TA1 and TA2 are shown in the following table. The terminals are the MKDS1 series, manufactured by Phoenix Contact GmbH & Co.

	<u>AWG</u>	<u>I(A)</u>	<u>VAC(V)</u>
Stranded	16	12	125
Solid	16	12	125
UL	22-16	10	300
CSA	22-16	10	300
CSA	22-16	10	300

**Encoder Selection**

The maximum frequency of the encoder output pulses that can be detected is 300 kHz. To find the output frequency, f (Hz), according to the following formula.

$$f \text{ (Hz)} = \frac{\text{Motor rotation speed (r/min) at max. frequency output} \times \text{Encoder constant (p/rev)}}{60}$$

If the encoder current requirements is 200 mA or greater, provide a separate power supply. (If momentary power loss ride-through function is necessary, provide back-up capacitor or take other necessary measures.)

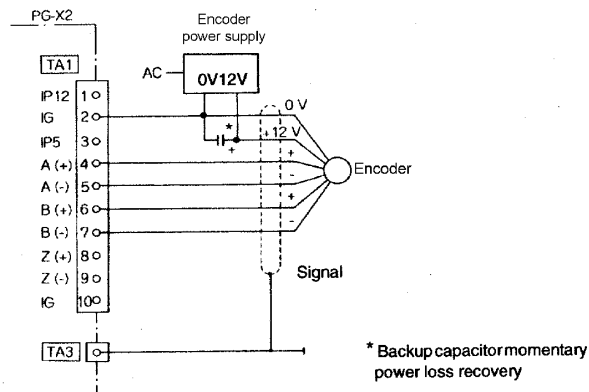

FIGURE 6: Connection example with encoder when using separate power supply

**Table 1: VG5 and VG5+ Encoder (PG) Parameter Settings**

Digital Operator Function Display	Digital Operator Display	Constant No.	Constant Name	Setting Range	Factory Setting	Change during Operation (O=Enable, x=Disable)	Data Selection	Control Method			
								V/f Control	V/f with PG Feedback	Open Loop Vector	Flux Vector
PG Option Setup	PG Pulse/Rev	F1-01	PG constant	0 to 60000	600	x		x	o	x	o
	PG Fdbk Loss Sel	F1-02	Operation selection at PG open circuit	0 to 3	1	x	0 : Ramp to Stop 1 : Coast to Stop 2 : Fast-Stop 3 : Alarm Only	x	o	x	o
	PG Overspeed Sel	F1-03	Operation selection at overspeed	0 to 3	1	x	0 : Ramp to Stop 1 : Coast to Stop 2 : Fast-Stop 3 : Alarm Only	x	o	x	o
	PG Deviation Sel	F1-04	Operation selection at deviation	0 to 3	1	x	0 : Ramp to Stop 1 : Coast to Stop 2 : Fast-Stop 3 : Alarm Only	x	o	x	o
	PG Rotation Sel	F1-05	PG rotation	0/1	0	x	0 : Fwd=C.C.W. 1 : Fwd=C.W.	x	o	x	o
	PG Output Ratio	F1-06	PG division rate	1 to 132	1	x		x	o	x	o
	PG Ramp P/I Sel	F1-07	Integral value during accel/decel enable/disable	0/1	0	x	0 : Disabled 1 : Enabled	x	o	x	x
	PG Overspd Level	F1-08	PG overspeed detection level	0 to 120%	115%	x		x	o	x	o
	PG Overspd Time	F1-09	PG overspeed detection delay time	0 to 2.0s	1.0s	x		x	o	x	o
	PG Deviate Level	F1-10	Excessive speed deviation detection level	0 to 50%	10%	x		x	o	x	o
	PG Deviate Time	F1-11	Excessive speed deviation detection delay time	0 to 2.0s	1.0s	x		x	o	x	o
	PG# Gear Teeth 1	F1-12	Number of PG gear teeth 1	0 to 1000	0	x		x	o	x	x
	PG# Gear Teeth 2	F1-13	Number of PG gear teeth 2	0 to 1000	0	x		x	o	x	x
ASR Tuning*	ASR P Gain 1	C5-01	ASR proportional gain 1	0 to 300.00	0.00	o		x	o	x	o
	ASR I Time 1	C5-02	ASR integral time 1	0 to 10.000sec	0.00sec	o		x	o	x	o
	ASR P Gain 2	C5-03	ASR proportional gain 2	0 to 300.00	0.00	o		x	o	x	o
	ASR I Time 2	C5-04	ASR integral time 2	0 to 10.000sec	0.00sec	o		x	o	x	o
	ASR Limit	C5-05	ASR limit	0.0 to 20.0%	0.0%	x		x	o	x	x
	ASR Delay Time	C5-06	ASR primary delay time	0.000 to 0.500s	0.000s	x		x	x	x	o
	ASR Gain SW Freq	C5-07	ASR switching frequency	0.0 to 400.0Hz	0.0Hz	x		x	x	x	o

\* ASR = Automatic Speed Regulation