



INSTRUCTION MANUAL

DOCUMENT NO. 027 - 2182
Rev. 1.01 Jun. 29, 2005

A faint, light gray world map is centered in the background of the page, showing the continents of North America, South America, Europe, Africa, Asia, and Australia.

***C10 MODBUS
Communications
Protocol***

Saftronics, Inc.

5580 Enterprise Pkwy
Ft. Myers, FL 33905
Tel. (239) 693 - 7200
Fax (239) 693 - 2431
www.saftronics.com

Contents

	Page
1- Introduction	3
2 - Specifications	3
3 - Terminal Wiring	3
4 - Related parameters for MODBUS communication Node address	3 – 4
<i>a. Node Address</i>	3
<i>b. Transfer Speed</i>	3
<i>c. Data Parity</i>	3
<i>d. Stopping Method while RS485 Communications Fault</i>	4
5 - C10 set-up with Host controller	4
<i>a. Operation procedure</i>	4
<i>b. Communication status indication of C10</i>	4
6 - Protocol Format	5 – 6
<i>a. MODBUS Message structure</i>	5
<i>b. Data bit format for MODBUS RTU mode</i>	5
<i>c. Follower Address</i>	5
<i>d. Function Code</i>	5
<i>e. Data Characters</i>	5
<i>f. CRC-16 data</i>	6
<i>g. C10 return messages</i>	6
7 – Message Format	7 – 9
<i>a. Read Command</i>	7
<i>b. Write Command</i>	8
<i>c. Loop Test Command</i>	8
<i>d. Write Holding Register Command</i>	9
8 – Holding Register Tag list	10 – 18
<i>a. Control Data Register (Read / Write)</i>	10
<i>b. Monitor Data Register (Read Only)</i>	11 - 14
<i>c. C10 Parameter Register (Read / Write)</i>	14 - 18
9 – Error Code	19
 Appendix – Example of RS232 communication application	 19 - 23

1. Introduction

The **C10** series inverter can communicate with a **PC** or **PLC** using the **RS485 MODBUS RTU mode** protocol.

2. Specifications

(a) **RS-485** interface is used.

(b) **MODBUS RTU** mode protocol

(c) **Communication Format** : (Set by **C10** parameters)

Transfer Speed: 1200/2400/4800/9600BPS (Set by parameter **Sn-37**)

Parity : no parity/even parity/odd parity (Set by parameter **Sn-38**)

3. Terminal Wiring

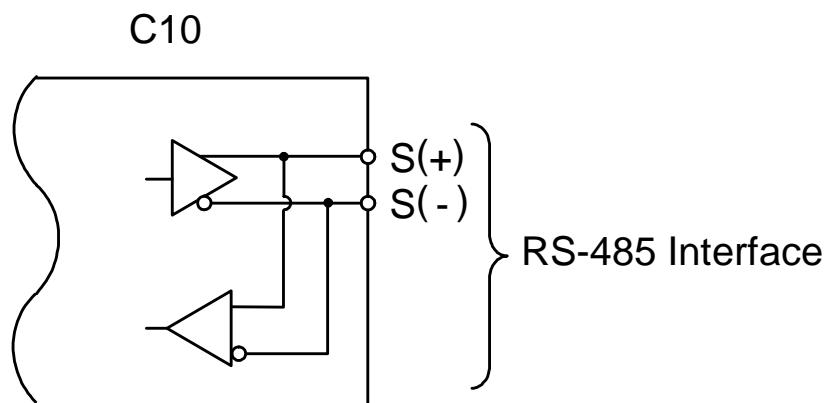

4. Related parameters for MODBUS communication Node address

(a) **Node Address**

Sn-36 = 1-31 **C10** Node address (Default = 1)

(b) **Transfer Speed** (Baud rate)

Sn-37 = 0 1200 BPS
 = 1 2400 BPS (Default = 1)
 = 2 4800 BPS
 = 3 9600 BPS
 = 4 19200 BPS (Firmware 55.02)

(c) **Data Parity**

Sn-38 = 0 No Parity (Default = 0)
 = 1 Even Parity
 = 2 Odd Parity

(d) Stopping Method while RS485 Communication Fault

- Sn-39** = 0 Decelerating to stop by **Bn-02**
 (Default = 0)
 = 1 Coasting to stop
 = 2 Decelerating to stop by **Bn-04**
 = 3 Continuous operation
 (Can be stopped by **STOP** Key)

(e) Time-out Check

- Cn-27** = 00.0 s Don't care
 = 01.0 s Checked Error (Default = 01.0 s)

5. C10 set-up with host controller**(a) Operation procedure**

1. Turn on the **C10** and set the related parameters.
2. Connect **C10** and host controller.
3. Host controller sends communication message.

(b) Communication status indication of C10

The Run/Stop command (**Sn-04**) or Frequency Reference (**Sn-05**) can be set via **RS-485** communication. The **C10** will display "**Alarm RS-485**" if it does not receive any message from the host controller after 5 seconds from power-up. This message will disappear after the **C10** has received messages from the host controller. If Time-out Check (**Cn-27**) is set, the **C10** will display "**Alarm RS-485**" if it does not receive any message within the time set by (**Cn-27**).

Parameter **Sn-39** sets the "**Alarm RS-485**" display format.

- Sn-39** = 0 Decelerate to stop by **Bn-02** ("**Alarm RS-485**" lights up)
 = 1 Coasting to stop ("**Alarm RS-485**" lights up)
 = 2 Decelerate to stop by **Bn-04** ("**Alarm RS-485**" lights up)
 = 3 Continuous operation ("**Alarm RS-485**" flash)

6. Protocol Format

- (a) A MODBUS RTU mode message consists of four parts: follower address, function code, data and CRC-16 character. The interval between two messages needs a 3.5 characters transferring time.

T1 T2 T3 T4	Follower Address	Function Code	Data Character	CRC-16 Character	T1 T2 T3 T4
-------------	------------------	---------------	----------------	------------------	-------------

T1~T4 : 3.5 min. characters transferring time.

- (b) Data bit format for MODBUS RTU mode

	LSB								MSB		
	Bit0	Bit1	Bit2	Bit3	Bit4	Bit5	Bit6	Bit7	Bit8	Bit9	Bit10
Even/Odd Parity	Start	1	2	3	4	5	6	7	8	Parity	Stop
No Parity	Start	1	2	3	4	5	6	7	8	Stop	Stop

- (c) Follower Address

Parameter ***Sn-36*** sets the node address of each ***C10 (1~31)***. Every follower receives the message sent from the host controller but only the one addressed returns a message to master. If the master sends a message with a follower address of 0, all followers will execute this command but do not return a message to master. ***This message can only be used for Run/Stop, Fault Reset (Address 0000H) and Frequency Reference (Address 0001H).***

- (d) Function Code

Code	Function	Note
03H	Read Data of Holding Register	-----
06H	Write Data to Single Register	-----
08H	Loop Test	-----
10H	Write Data to Holding Register	the Follower Address can be 0

- (e) Data Characters

Detail descriptions will be explained later in this manual.

(f) CRC-16 data***CRC-16 Generation Procedure.***

1. Load a 16-bit register with FFFFH. Call this the **CRC** register.
2. Exclusive OR the first 8-bit byte of the message with the low order byte of the 16-bit CRC register, putting the result in the CRC register.
3. Shift the CRC register one bit to the right (toward the LSB), zero filling the MSB. Extract and examine the LSB.
4. If LSB is 0, repeat procedure c (another shift).If LSB is 1, Exclusive OR the CRC register with the polynomial value A001H.
5. Repeat procedure **3 & 4** until eight shifts have been performed. When this is done, a complete byte will have been processed.
6. Repeat procedures **2 thru 5** for the following byte of the message until all bytes of the message are processed. Now, the value of CRC register is the CRC- 6 data.
7. When the CRC is placed into the message, the upper and lower bytes must be swapped.

(g) C10 return messages

1. Please refer to the “Message Format” on the next page for a more detailed description of the **C10** returning messages.
2. The **C10** needs 5ms to return messages after receiving a normal message from the host controller.
3. In the next two cases, the **C10** does not return any message :
 - A - An error is detected in received data message (parity error, framing error, overrun error or CRC-16 error).
 - B - The Follower Address is different from parameter **Sn-36** (**C10** Follower No.).

7. Message Format

The C10 supports three MODBUS Function Codes.

Table 1 Message Length

Function	Code	Function	Host Query		C10 Return	
			Byte (Min.)	Byte (Max.)	Byte (Min.)	Byte (Max.)
Data Read	03H	Read Data from Holding Register	8	8	7	37
Data Write	06H	Write Data to Single Holding Register	8	8	8	8
Loop Test	08H	Loop Test	8	8	8	8
Data Write	10H	Write Data to Holding Register	11	41	8	8

(a) **Read Command** : Read data from Holding Register (refer to p. **10 – 18** to see the holding register tag list)

Host Query

Follower Address		01H
Function Code		03H
Register Address	High Byte	00H
	Low Byte	00H
Register Count (*1)	High Byte	00H
	Low Byte	01H
CRC-16	Low Byte	84H
	High Byte	0AH

C10 Return (Normal)

Follower Address		01H
Function Code		03H
Data Byte Count		02H
Data	High Byte	00H
	Low Byte	00H
CRC-16	Low Byte	B8H
	High Byte	44H

*1 Host controller can read up to 16 registers in each transferring message

C10 Return (Error Detected)

Follower Address		01H
80H + Function Code		83H
Error Code		03H
CRC-16	Low Byte	01H
	High Byte	31H

(b) Write Command : Write Data to Single Holding Register (*2)

Host Query

Follower Address		01H
Function Code		06H
Address (*1)	High Byte	00H
	Low Byte	00H
Data	High Byte	00H
	Low Byte	01H
CRC-16	Low Byte	48H
	High Byte	0AH

C10 Return (Normal)

Follower Address		01H
Function Code		06H
Address (*1)	High Byte	00H
	Low Byte	00H
Data	High Byte	00H
	Low Byte	01H
CRC-16	Low Byte	48H
	High Byte	0AH

C10 Return (Error Detected)

Follower Address		01H
80H + Function Code		86H
Error Code		01H
CRC-16	Low Byte	83H
	High Byte	A0H

*1 If follower address is 0 (valid for address 0000H and 0001H only), all follower **C10s**' will execute this command but do not return message to master.

*2 Parameters modified will not be saved to EEPROM automatically. Parameters can be saved to EEPROM by writing data to address 0900H.

(c) Loop Test Command (test C10 communication status)

Host Query

Follower Address		01H
Function Code		08H
Test Code	High Byte	00H
	Low Byte	00H
Test Data (*1)	High Byte	AAH
	Low Byte	55H
CRC-16	Low Byte	5EH
	High Byte	94H

*1 The test data is arbitrary.

C10 Return (Normal)

Follower Address		01H
Function Code		08H
Test Code	High Byte	00H
	Low Byte	00H
Test Data	High Byte	AAH
	Low Byte	55H
CRC-16	Low Byte	5EH
	High Byte	94H

C10 Return (Error Detected)

Follower Address		01H
80H + Function Code		88H
Error Code		01H
CRC-16	Low Byte	87H
	High Byte	C0H

(d) Write Holding Register Command (*4)**Host Query**

Follower Address		01H
Function Code		10H
Register address (*3)	High Byte	00H
	Low Byte	00H
Register Count (*1)	High Byte	00H
	Low Byte	01H
Data Byte Count (*2)		02H
Data	High Byte	00H
	Low Byte	01H
CRC-16	Low Byte	67H
	High Byte	90H

C10 Return (Normal)

Follower Address		01H
Function Code		10H
Register address	High Byte	00H
	Low Byte	00H
Register Count (*1)	High Byte	00H
	Low Byte	01H
CRC-16		Low Byte 01H

- *1. Host controller can write to a maximum of 16 registers each time.
- *2. Data Byte Count = 2 * Access Count.
- *3. If follower address of host query message is 0, all follower C10s' will execute this command but do not return message to master.
- *4. Parameters modified will not be saved to EEPROM automatically. Parameters to EEPROM can be saved by writing data to address 0900H.

C10 Return (Error Detected)

Follower Address		01H
80H+Function Code		90H
Error Code		03H
CRC-16	Low Byte	0CH
	High Byte	01H

8. Holding Register Tag List

(a) Control Data Register (Read / Write)

Address	Bits	Function Description
0000H (*1)	0	0 : STOP 1 : RUN
	1	0 : Forward 1 : Reverse
	2	External Fault : 0 : Clear 1 : Set
	3	Fault Reset : 0 : Clear 1 : Set
	4	Reserved
	5	Reserved
	6	Reserved
	7	Reserved
	8	1 : PRG mode → DRV mode, Auto-reset to 0 0 : Invalid
	9	1 : DRV mode → PRG mode, Auto-reset to 0 0 : Invalid
	10	Reserved
	11	Reserved
	12	Reserved
	13	Reserved
	14	Reserved
15	Reserved	
0001H (*1)	Host Link Frequency Reference : 7530H/100% (30000/100%=Cn-02)	
0002H	Reserved	
0003H	Reserved	
0004H	Reserved	
0005H	Analog Output 1 Command : 10V/100.0%	
0006H	Analog Output 2 Command : 10V/100.0%	
0007H	0	Relay Output (RA-RB-RC) Command 0 : Clear 1 : Set
	1	Digital Output (DO1) Command 0 : Clear 1 : Set
	2	Digital Output (DO2) Command 0 : Clear 1 : Set
	3	Reserved
	4	Reserved
	5	Reserved
	6	Reserved
	7	Reserved
	8	Reserved
	9	Reserved
	10	Reserved
	11	Reserved
	12	Reserved
	13	Reserved
	14	Reserved
15	Reserved	

Monitor Data Register (Read Only) Con't

0021H	0	1 : Under Voltage Fault (UV1)
	1	1 : Over Current Fault (OC)
	2	1 : Over Voltage Fault (OV)
	3	1 : Over Heat Fault (OH)
	4	1 : Motor Over Load Fault (OL1)
	5	1 : C10 Over Load Fault (OL2)
	6	1 : Output Over Torque Fault (OL3)
	7	1 : External Fault 3 (EF3)
	8	1 : External Fault 5 (EF5)
	9	1 : External Fault 6 (EF6)
	10	1 : External Fault 7 (EF7)
	11	1 : External Fault 8 (EF8)
	12	1 : EEPROM Fault (CPF04)
	13	1 : CPU A/D Fault (CPF05)
	14	1 : Ground Fault (GF)
15	1 : PG Over Speed Fault	
0022H	0	1 : PG Speed Deviation Alarm
	1	1 : PG Line Alarm
	2	1 : Braking Resistor Over Heat Alarm
	3	1 : RS-485 Communication Alarm
	4	Reserved
	5	Reserved
	6	Reserved
	7	Reserved
	8	Reserved
	9	Reserved
	10	Reserved
	11	Reserved
	12	Reserved
	13	Reserved
	14	Reserved
15	Reserved	

Monitor Data Register (Read Only) Con't

0023H	0	1 : Under Voltage Alarm (UV1)		
	1	1 : Over Voltage Alarm (OV)		
	2	1 : Over Heat Alarm (OH)		
	3	1 : Output Over Torque Alarm (OL3)		
	4	1 : Two Line Terminal 1,2 External Alarm (EF)		
	5	1 : Base Block Alarm (BB)		
	6	1 : EEPROM Alarm		
	7	1 : External Alarm 3 (EF3)		
	8	1 : PG Over Speed Alarm		
	9	1 : PG Speed Deviation Alarm		
	10	1 : PG Line Alarm		
	11	1 : Braking Resistor Over Heat Alarm		
	12	1 : RS-485 Communication Alarm		
	13	Reserved		
	14	Reserved		
15	Reserved			
Address	Function		Description	
0024H	Frequency Reference		(30000/100%) 100%=Cn-02	
0025H	Output Frequency		(30000/100%) 100%=Cn-02	
0026H	PG Speed Feedback		(1000/100.0%) 100.0%=Cn-02	
0027H	Output Current		0.1A/1	
0028H	DC Voltage		1V/1	
0029H	Analog Input VIN value		10V/100.0%	
002AH	Analog Input AIN value		20mA/100.0%	
002BH	Analog Input AUX value		10V/100.0%	
002CH	Digital Input Status		0	1 : Close (DI①)
			1	1 : Close (DI②)
			2	1 : Close (DI③)
			3	1 : Close (DI④)
			4	1 : Close (DI⑤)
			5	1 : Close (DI⑥)
			6	1 : Close (DI⑦)
			7	1 : Close (DI⑧)
			8	Reserved
			9	Reserved
			10	Reserved
			11	Reserved
			12	Reserved
			13	Reserved
			14	Reserved
15	Reserved			

Monitor Data Register (Read Only) Con't

002DH	Analog Output AO1 Value	10V/100.0%	
002EH	Analog Output AO2 Value	10V/100.0%	
002FH	Digital Output Status	0	1 : Close (RA-RB-RC)
		1	1 : Close (DO1-DOG)
		2	1 : Close (DO2-DOG)
		3	Reserved
		4	Reserved
		5	Reserved
		6	Reserved
		7	Reserved
		8	Reserved
		9	Reserved
		10	Reserved
		11	Reserved
		12	Reserved
		13	Reserved
		14	Reserved
15	Reserved		

(c) C10 Parameter Register(Read/Write)

Address	Parameter	Unit
0101H	Sn-01 (C10 Capacity Selection)	-
0102H	Sn-02 (V/F Curve Selection)	-
0103H	Sn-03 (Operation Display)	-
0104H	Sn-04 (Run Source Selection)	-
0105H	Sn-05 (Frequency Command Selection)	-
0106H	Sn-06 (Stopping Method Selection)	-
0107H	Sn-07 (Priority of Stopping)	-
0108H	Sn-08 (Prohibition of REV Run)	-
0109H	Sn-09 (Output Frequency UP/DOWN Function)	-
010AH	Sn-10 (Frequency Command Characteristics Selection)	-
010BH	Sn-11 (Scanning Times at Input Terminal)	-
010CH	Sn-12 (Over Torque detection Selection)	-
010DH	Sn-13 (Output Voltage Limit Selection)	-
010EH	Sn-14 (Stall Prevention during Accel. Function Selection)	-
010FH	Sn-15 (Stall Prevention during Decel. Function Selection)	-
0110H	Sn-16 (Stall Prevention during Running Function Selection)	-
0111H	Sn-17 (Fault Retry Setting)	-
0112H	Sn-18 (Operation Selection at Power Loss)	-
0113H	Sn-19 (Zero Speed Braking Operation Selection)	-

C10 Parameter Register(Read/Write) Con't

0114H	Sn-20 (External Fault 3 Contact Selection)	-
0115H	Sn-21 (External Fault 3 Detection Selection)	-
0116H	Sn-22 (External Fault Operation Selection)	-
0117H	Sn-23 (Motor Overload Protection Selection)	-
0118H	Sn-24 (Vin, Ain Function Selection)	-
0119H	Sn-25 (DI⑤ Function Selection)	-
011AH	Sn-26 (DI⑥ Function Selection)	-
011BH	Sn-27 (DI⑦ Function Selection)	-
011CH	Sn-28 (DI⑧ Function Selection)	-
011DH	Sn-29 (Aux. Function Selection)	-
011EH	Sn-30 (RA-RB-RC Function Selection)	-
011FH	Sn-31 (DO1 Function Selection)	-
0120H	Sn-32 (DO2 Function Selection)	-
0121H	Sn-33 (AO1 Function Selection)	-
0122H	Sn-34 (AO2 Function Selection)	-
0123H	Sn-35 (Pulse Output Multiplier Selection)	-
0124H	Sn-36 (C10 Address)	-
0125H	Sn-37 (RS-485 Communication Baud Rate Setting)	-
0126H	Sn-38 (RS-485 Communication Parity Setting)	-
0127H	Sn-39 (RS-485 Communication Fault Stop Setting)	-
0128H	Sn-40 (PG Speed Control Function)	-
0129H	Sn-41 (Operation Selection at PG Open Circuit)	-
012AH	Sn-42 (Operation Selection at PG Large Speed Deviation)	-
012BH	Sn-43 (Operation Selection at PG Over Speed Deviation)	-
012CH	Sn-44 (Operation Mode Selection during Auto Run)	-
012DH	Sn-45 (Auto Run Mode Operation Selection 1)	-
012EH	Sn-46 (Auto Run Mode Operation Selection 2)	-
012FH	Sn-47 (Auto Run Mode Operation Selection 3)	-
0130H	Sn-48 (Auto Run Mode Operation Selection 4)	-
0131H	Sn-49 (Auto Run Mode Operation Selection 5)	-
0132H	Sn-50 (Auto Run Mode Operation Selection 6)	-
0133H	Sn-51 (Auto Run Mode Operation Selection 7)	-
0134H	Sn-52 (Auto Run Mode Operation Selection 8)	-
0135H	Sn-53 (Auto Run Mode Operation Selection 9)	-
0136H	Sn-54 (Auto Run Mode Operation Selection 10)	-
0137H	Sn-55 (Auto Run Mode Operation Selection 11)	-
0138H	Sn-56 (Auto Run Mode Operation Selection 12)	-
0139H	Sn-57 (Auto Run Mode Operation Selection 13)	-
013AH	Sn-58 (Auto Run Mode Operation Selection 14)	-
013BH	Sn-59 (Auto Run Mode Operation Selection 15)	-
013CH	Sn-60 (Auto Run Mode Operation Selection 16)	-
013DH	Sn-61 (Applied Torque Mode)	-

C10 Parameter Register(Read/Write) Con't

013EH	Sn-62 (Language Selection)	-
013FH	Sn-63 (Parameter Copy)	-
0140H	Sn-64 (PID Function)	-
0141H	Sn-65 (Braking Resistor Protection)	-
0200H	Cn-01 (Input Voltage)	0.1V
0201H	Cn-02 (Max. Output Frequency)	0.1Hz
0202H	Cn-03 (Max. Output Voltage)	0.1V
0203H	Cn-04 (Rated Output Frequency)	0.1Hz
0204H	Cn-05 (Middle Output Frequency)	0.1Hz
0205H	Cn-06 (Voltage at Middle Output Frequency)	0.1V
0206H	Cn-07 (Min. Output Frequency)	0.1Hz
0207H	Cn-08 (Voltage at Min. Output Frequency)	0.1V
0208H	Cn-09 (Motor Rated Current)	0.1A
0209H	Cn-10 (No-load Current of Motor)	1%
020AH	Cn-11 (Rated Slip of Motor)	0.10%
020BH	Cn-12 (Line-to-line Resistor of Motor)	0.001Ω
020CH	Cn-13 (Torque Compensation of Core Loss)	1W
020DH	Cn-14 (DC Injection Barking Starting Frequency)	0.1Hz
020EH	Cn-15 (DC Braking Current)	1%
020FH	Cn-16 (DC Injection Braking Time at Stop)	0.1s
0210H	Cn-17 (DC Injection Braking Time at Start)	0.1s
0211H	Cn-18 (Frequency Command Upper Bound)	1%
0212H	Cn-19 (Frequency Command Lower Bound)	1%
0213H	Cn-20 (Frequency Jump 1)	0.1Hz
0214H	Cn-21 (Frequency Jump 2)	0.1Hz
0215H	Cn-22 (Frequency Jump 3)	0.1Hz
0216H	Cn-23 (Frequency Jump Width)	0.1Hz
0217H	Cn-24 (Number of Retry Attempt)	1
0218H	Cn-25 (Stall Prevention Level during Accel.)	1%
0219H	Cn-26 (Stall Prevention Level during Running)	1%
021AH	Cn-27 (Communication Fault Detection Time)	0.1s
021BH	Cn-28 (LCD Digital Operator Display Unit)	1
021CH	Cn-29 (Freq. Agree Detection Level During Accel.)	0.1Hz
021DH	Cn-30 (Freq. Agree Detection Level During Decel.)	0.1Hz
021EH	Cn-31 (Frequency Agree Detection Width)	0.1Hz
021FH	Cn-32 (Over Torque Detection Level)	1%
0220H	Cn-33 (Over Torque Detection Time)	0.1s
0221H	Cn-34 (Carrier Frequency Setting)	1
0222H	Cn-35 (Speed Search Detection Level)	1%
0223H	Cn-36 (Speed Search Time)	0.1s
0224H	Cn-37 (Min. Base Block Time)	0.1s
0225H	Cn-38 (V/F Curve in Speed Search)	1%
0226H	Cn-39 (Low Voltage Alarm Detection Level)	1V
0227H	Cn-40 (Slip Compensation Primary Delay Time)	0.1s
0228H	Cn-41 (S-curve Characteristic Time at Accel. Start)	0.1s

C10 Parameter Register (Read/Write) Con't

0229H	Cn-42 (S-curve Characteristic Time at Accel. End)	0.1s
022AH	Cn-43 (S-curve Characteristic Time at Decel. Start)	0.1s
022BH	Cn-44 (S-curve Characteristic Time at Decel. End)	0.1s
022CH	Cn-45 (PG Parameter)	0.1P/R
022DH	Cn-46 (Pole no. of Motor)	2P
022EH	Cn-47 (ASR Proportional 1)	0.01
022FH	Cn-48 (ASR Integral Time 1)	0.1s
0230H	Cn-49 (ASR Proportional 2)	0.01
0231H	Cn-50 (ASR Integral Time 2)	0.1s
0232H	Cn-51 (ASR Upper Bound)	0.1%
0233H	Cn-52 (ASR Lower Bound)	0.1%
0234H	Cn-53 (Excessive Speed Deviation Detection Level)	1%
0235H	Cn-54 (Over Speed Detection Level)	1%
0236H	Cn-55 (PID Integral Upper Bound)	1%
0237H	Cn-56 (PID Primary Delay Time Constant)	0.1s

0400H	An-01 (Frequency Command 1)	0.01Hz	*1
0401H	An-02 (Frequency Command 2)	0.01Hz	*1
0402H	An-03 (Frequency Command 3)	0.01Hz	*1
0403H	An-04 (Frequency Command 4)	0.01Hz	*1
0404H	An-05 (Frequency Command 5)	0.01Hz	*1
0405H	An-06 (Frequency Command 6)	0.01Hz	*1
0406H	An-07 (Frequency Command 7)	0.01Hz	*1
0407H	An-08 (Frequency Command 8)	0.01Hz	*1
0408H	An-09 (Frequency Command 9)	0.01Hz	*1
0409H	An-10 (Frequency Command 10)	0.01Hz	*1
040AH	An-11 (Frequency Command 11)	0.01Hz	*1
040BH	An-12 (Frequency Command 12)	0.01Hz	*1
040CH	An-13 (Frequency Command 13)	0.01Hz	*1
040DH	An-14 (Frequency Command 14)	0.01Hz	*1
040EH	An-15 (Frequency Command 15)	0.01Hz	*1
040FH	An-16 (Frequency Command 16)	0.01Hz	*1
0410H	An-17 (Jog Frequency Command)	0.01Hz	*1
0500H	Bn-01 (Acceleration Time 1)	0.1s	*1
0501H	Bn-02 (Deceleration Time 1)	0.1s	*1
0502H	Bn-03 (Acceleration Time 2)	0.1s	*1
0503H	Bn-04 (Deceleration Time 2)	0.1s	*1
0504H	Bn-05 (Analog Frequency Cmd. Gain(Voltage))	0.1%	*1
0505H	Bn-06 (Analog Frequency Cmd. Bias(Voltage))	0.1%	*1
0506H	Bn-07 (Analog Frequency Cmd. Gain(Current))	0.1%	*1
0507H	Bn-08 (Analog Frequency Cmd. Bias(Current))	0.1%	*1
0508H	Bn-09 (Multi-Function Analog Input Gain)	0.1%	*1
0509H	Bn-10 (Multi-Function Analog Input Bias)	0.1%	*1
050AH	Bn-11 (Auto Torque Boost Gain)	0.1	*1
0BH	Bn-12 (Monitor 1)	1	*1

C10 Parameter Register(Read/Write) Con't

050CH	Bn-13 (Monitor 2)	1	*1
050DH	Bn-14 (Multi-Function analog Output AO1 Gain)	0.01	*1
050EH	Bn-15 (Multi-Function analog Output AO2 Gain)	0.01	*1
050FH	Bn-16 (PID Detection Gain)	0.01	*1
0510H	Bn-17 (PID Proportional Gain)	0.01	*1
0511H	Bn-18 (PID Integral Time)	0.01s	*1
0512H	Bn-19 (PID Differential Time)	0.01s	*1
0513H	Bn-20 (PID Bias)	1%	*1
0514H	Bn-21 (1st Step Time Under Auto Run Mode)	0.1s	*1
0515H	Bn-22 (2nd Step Time Under Auto Run Mode)	0.1s	*1
0516H	Bn-23 (3rd Step Time Under Auto Run Mode)	0.1s	*1
0517H	Bn-24 (4th Step Time Under Auto Run Mode)	0.1s	*1
0518H	Bn-25 (5th Step Time Under Auto Run Mode)	0.1s	*1
0519H	Bn-26 (6th Step Time Under Auto Run Mode)	0.1s	*1
051AH	Bn-27 (7th Step Time Under Auto Run Mode)	0.1s	*1
051BH	Bn-28 (8th Step Time Under Auto Run Mode)	0.1s	*1
051CH	Bn-29 (9th Step Time Under Auto Run Mode)	0.1s	*1
051DH	Bn-30 (10th Step Time Under Auto Run Mode)	0.1s	*1
051EH	Bn-31 (11th Step Time Under Auto Run Mode)	0.1s	*1
051FH	Bn-32 (12th Step Time Under Auto Run Mode)	0.1s	*1
0520H	Bn-33 (13th Step Time Under Auto Run Mode)	0.1s	*1
0521H	Bn-34 (14th Step Time Under Auto Run Mode)	0.1s	*1
0522H	Bn-35 (15th Step Time Under Auto Run Mode)	0.1s	*1
0523H	Bn-36 (16th Step Time Under Auto Run Mode)	0.1s	*1
0524H	Bn-37 (Timer Function ON Delay Time)	0.1s	*1
0525H	Bn-38 (Timer Function OFF Delay Time)	0.1s	*1
0526H	Bn-39 (Energy Saving Gain)	1%	*1
0900H	Save An, Bn, Sn and Cn into EEPROM	-	*1

***1 Parameters can be written in DRV mode or PRG mode.**

***2 Writing data 0000H to this address in PRG mode can save parameter to EEPROM.**

- All parameters can be read in PRG mode or DRV mode, but some parameters can be written in PRG mode only.

9. Error Code

Code	Description	Possible Cause
00H	CRC Code Error	CRC Word (High or Low Byte) Error
01H	Function Code Error	Function code is not 03H, 08H or 10H.
02H	Register Address Error	Register address is not in the range that can be accessed.
03H	Data Value Error	Data value is over range in writing message.
04H	Parameter Save Failure	Can not save into EEPROM.
06H	Parameter Save Busy	Saving into EEPROM is doing.
Not Response	UART Error	Parity, Overrun, Frame error.
Not Response	Data Format Error	Data string is not correct.

Appendix: Example of RS-485 Communication Application

A. Set C10 parameters

Sn-36 = 5 (C10 Follower Address), Sn=37, Sn-38, Sn=39, Cn-27

Sn-04 = 2 (Run/Stop by RS-485)

Sn-05 = 2 (Frequency Reference by RS-485)

Sn-30 = 22 (RA Output by RS-485), Sn-31 = 22 (DO1 Output by RS-485)

B. To control the C10 with the Host Controller via RS-485 serial communication proceed with the following four steps.

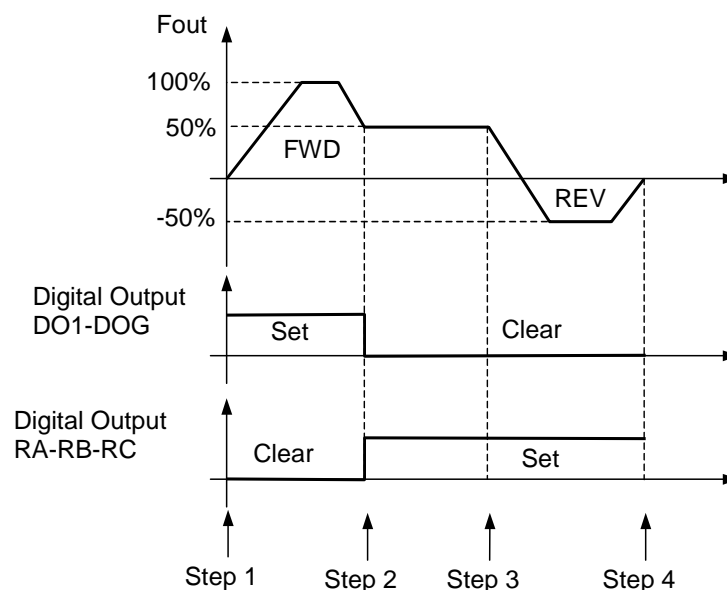

Step 1 – Run **C10** forward with 100% speed. (Set **DO1-DOG**)

Host Query

Follower Address		01H
Function Code		10H
Register Address	High Byte	00H
	Low Byte	00H
Register Count	High Byte	00H
	Low Byte	08H
Data Byte Count		10H
Data Value 1	High Byte	00H
	Low Byte	01H
Data Value 2	High Byte	75H
	Low Byte	30H
Data Value 3	High Byte	00H
	Low Byte	00H
Data Value 4	High Byte	00H
	Low Byte	00H
Data Value 5	High Byte	00H
	Low Byte	00H
Data Value 6	High Byte	00H
	Low Byte	00H
Data Value 7	High Byte	00H
	Low Byte	00H
Data Value 8	High Byte	00H
	Low Byte	02H
CRC-16	Low Byte	6CH
	High Byte	49H

C10 Return

Follower Address		01H
Function Code		10H
Register Address	High Byte	00H
	Low Byte	00H
Register Count	High Byte	00H
	Low Byte	08H
CRC-16	Low Byte	C1H
	High Byte	CFH

Data Value1 of Address 0000H = 0001H : Run **C10** Forward.

Data Value2 of Address 0001H = 7530H : Speed Reference 100%.

(Corresponding to Maximum Frequency Cn-02)

Data Value8 of Address 0007H = 0002H : Set DO1-DOG.

- When the **C10** received this message , it will start, accelerate to 100% speed in forward direction and set digital output terminal **DO1-DOG**.

Step 2 – Run **C10** forward with 50% speed. (Clear **DO1-DOG** Set **RA-RB-RC**.)

Host Query

Follower Address		01H
Function Code		10H
Register Address	High Byte	00H
	Low Byte	00H
Register Count	High Byte	00H
	Low Byte	08H
Data Byte Count		10H
Data Value 1	High Byte	00H
	Low Byte	01H
Data Value 2	High Byte	3AH
	Low Byte	98H
Data Value 3	High Byte	00H
	Low Byte	00H
Data Value 4	High Byte	00H
	Low Byte	00H
Data Value 5	High Byte	00H
	Low Byte	00H
Data Value 6	High Byte	00H
	Low Byte	00H
Data Value 7	High Byte	00H
	Low Byte	00H
Data Value 8	High Byte	00H
	Low Byte	01H
CRC-16	Low Byte	FDH
	High Byte	2EH

C10 Return

Follower Address		01H
Function Code		10H
Register Address	High Byte	00H
	Low Byte	00H
Register Count	High Byte	00H
	Low Byte	08H
CRC-16	Low Byte	C1H
	High Byte	CFH

Data Value1 of Address 0000H = 0001H : Run **C10** Forward.

Data Value2 of Address 0001H = 3A98H : Speed Reference 50%.

Data Value8 of Address 0007H = 0001H : Set RA-RB-RC. Clear DO1-DOG.

- When the **C10** receives this message, it will decelerate to 50% speed in forward direction, clear the digital output terminal **DO1-DOG** and set the digital output **RA-RB-RC**.

Step 3 – Run **C10** reverse with 50% speed. (Set **RA-RB-RC**.)

Host Query

Follower Address		01H
Function Code		10H
Register Address	High Byte	00H
	Low Byte	00H
Register Count	High Byte	00H
	Low Byte	08H
Data Byte Count		10H
Data Value 1	High Byte	00H
	Low Byte	03H
Data Value 2	High Byte	3AH
	Low Byte	98H
Data Value 3	High Byte	00H
	Low Byte	00H
Data Value 4	High Byte	00H
	Low Byte	00H
Data Value 5	High Byte	00H
	Low Byte	00H
Data Value 6	High Byte	00H
	Low Byte	00H
Data Value 7	High Byte	00H
	Low Byte	00H
Data Value 8	High Byte	00H
	Low Byte	01H
CRC-16	Low Byte	7FH
	High Byte	2FH

C10 Return

Follower Address		01H
Function Code		10H
Register Address	High Byte	00H
	Low Byte	00H
Register Count	High Byte	00H
	Low Byte	08H
CRC-16	Low Byte	C1H
	High Byte	CFH

Data Value1 of Address 0000H = 0003H : Run **C10** Reverse.

Data Value2 of Address 0001H = 3A98H : Speed Reference 50%.

Data Value8 of Address 0007H = 0001H : Set **RA-RB-RC**.

- When the **C10** receives this message, it will run at 50% speed in reverse direction, clear the digital output terminal **DO1-DOG** and set the digital output **RA-RB-RC**.

Step 4 – Stop C10. (Set RA-RB-RC.)**Host Query**

Follower Address		01H
Function Code		10H
Register Address	High Byte	00H
	Low Byte	00H
Register Count	High Byte	00H
	Low Byte	00H
Data Byte Count		02H
Data Value 1	High Byte	00H
	Low Byte	00H
CRC-16	Low Byte	A6H
	High Byte	50H

C10 Return

Follower Address		01H
Function Code		10H
Register Address	High Byte	00H
	Low Byte	00H
Register Count	High Byte	00H
	Low Byte	01H
CRC-16	Low Byte	C1H
	High Byte	CFH

Data Value1 of Address 0000H = 0000H : Stop **C10**.

- When the **C10** received this message, it will stop and decelerate to zero speed, digital output terminal **DO1-DOG** and **RA-RB-RC** do not change their status.