



# CSX & CSXi

## Compact Starter Series



## Remote Operator Manual

Saftronics, Inc.  
5580 Enterprise Pkwy., Ft. Myers, FL 33905  
Telephone: (239) 693-7200  
Fax: (239) 693-2431  
www.saftronics.com

REV December 2004  
PART NUMBER 027-2180

---

<b>Section 1</b>	<b>Introduction</b>	
	1.1 Important User Information .....	2
	1.2 General Description .....	2
<hr/>		
<b>Section 2</b>	<b>Installation</b>	
	2.1 Mounting .....	3
	2.2 Connection .....	4
<hr/>		
<b>Section 3</b>	<b>Specifications</b>	
	3.1 General Technical Data .....	5
	3.2 Dimensions .....	6
<hr/>		
<b>Section 4</b>	<b>Operation</b>	
	4.1 Functionality Range.....	6
	4.2 Operation .....	7
	4.3 Trip Codes .....	8
<hr/>		
<b>Section 5</b>	<b>4-20 mA Analog Output</b>	
	5.1 Overview .....	8
	5.2 Calibration .....	8
	5.3 Programming .....	8
<hr/>		
<b>Section 6</b>	<b>Troubleshooting</b>	
	6.1 General Faults .....	10

---

---

## Section 1 Introduction

---

### 1.1 Important User Information

Observe all necessary safety precautions when controlling the soft starter remotely. Alert personnel that machinery may start without warning.

It is the installer's responsibility to follow all instructions in this manual and to follow correct electrical practice.

Use all internationally recognised standard practice for RS485 communications when installing and using this equipment.

***The information contained in this manual is subject to change at any time and without prior notice. In no event will responsibility or liability be accepted for direct, indirect or consequential damages resulting from the use or application of this equipment***

### 1.2 General Description

The Remote Operator allows remote operation of the CSX Series soft starters, and offers the following functionality:

- Operational Control (Start, Stop, Quick Stop and Reset)
- Starter Status Monitoring (Start, Run and Trip)
- Performance Monitoring (Motor Current and Motor Temperature)
- Trip Code Display
- 4-20 mA Analog Output (Motor Current)
- Optional RS485 Network Connection <sup>1</sup>

<sup>1</sup> The Remote Operator can act as a gateway device for connection to an RS485 serial communications network, allowing remote control of a motor from an RS485 network using Modbus RTU or standard AP ASCII communications protocol. For further information, please refer to the Modbus Interface Installation Instructions.



#### NOTE

In order to use the Remote Operator with CSX Series starters, a Remote Operator Interface must also be installed.

---

## Section 2 Installation

---

This section describes the installation and connection procedures to use the Remote Operator for basic control and monitoring of a soft starter. The Remote Operator is pre-configured to control a soft starter once control supply power is applied to both devices. For basic operation, no parameter adjustments are required on the Remote Operator or the soft starter.

In order to use the Remote Operator's 4-20 mA Analog Output to monitor motor current, follow the instructions in **Error! Reference source not found.**

## 2.1 Mounting

The Remote Operator is rated IP54 or NEMA 12<sup>1</sup> when mounted correctly in accordance with these instructions. It is intended for use on the flat surface of a panel, with all external wiring connected from behind the panel.

The Remote Operator is supplied with a mounting bracket and four fasteners. The built-in gasket seal guarantees protection from outside the panel.

Select the panel location of the Remote Operator. The required panel cutout is 92 x 92 mm. Place the Remote Operator through the cutout and locate the mounting bracket at the rear of the panel onto the four studs. Use the four fasteners to tighten the mounting bracket up to the rear of the panel.

<sup>1</sup> For use on a flat surface of a NEMA 1 or NEMA 12 enclosure.

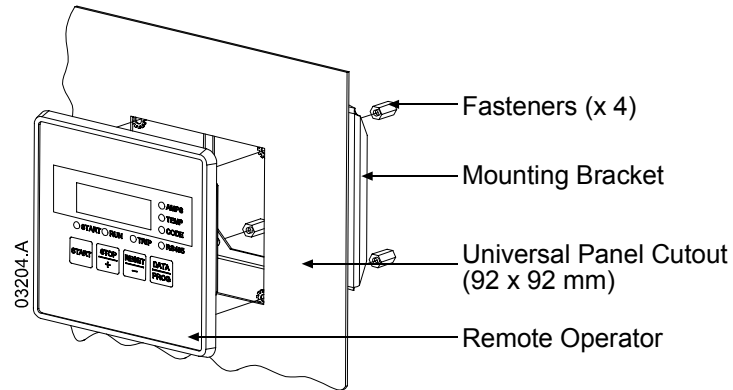

## 2.2 Connection

The Remote Operator requires a minimum of three electrical connections – the external power supply, the chassis earth and the RS485 Starter port to the soft starter. All external wiring, except the chassis earth (M4 stud provided), is connected to spring operated clamp connector terminals with a maximum wire size of 2.5 mm<sup>2</sup>. No special tools are required.

Once the Remote Operator is mounted, connect it to the starter as illustrated below.

### Grounding and Shielding

Twisted pair data cable with earth shield is recommended. The cable shield should be connected to a GND device terminal at both ends and one point of the site protective earth.

### Termination Resistors

In long cable runs prone to excessive noise interference, termination resistors should be installed between B1 (–) and B3 (+) of the soft starter and the Remote Operator. This resistance should match the cable impedance (typically 120 Ω). Do not use wire wound resistors.

### For Use with CSX Series

In order to use the Remote Operator with CSX Series soft starters, a Remote Operator Interface must first be installed to the starter using the following steps:

1. Remove control power and mains supply from the CSX.
2. Attach the Remote Operator Interface to the side of the CSX as illustrated.

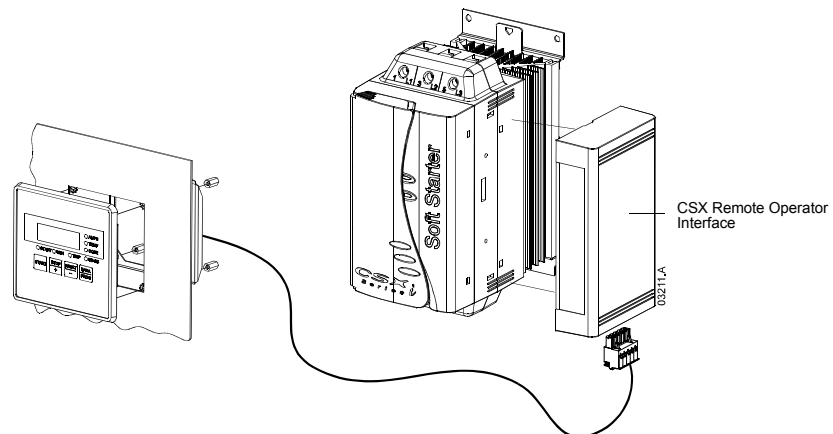

### NOTE

Control power and mains supply must be removed from the soft starter before attachment or removal of accessory modules. Failure to do so may result in equipment damage.

Once the Remote Operator Interface has been installed, wire between the Remote Operator and the interface as follows:

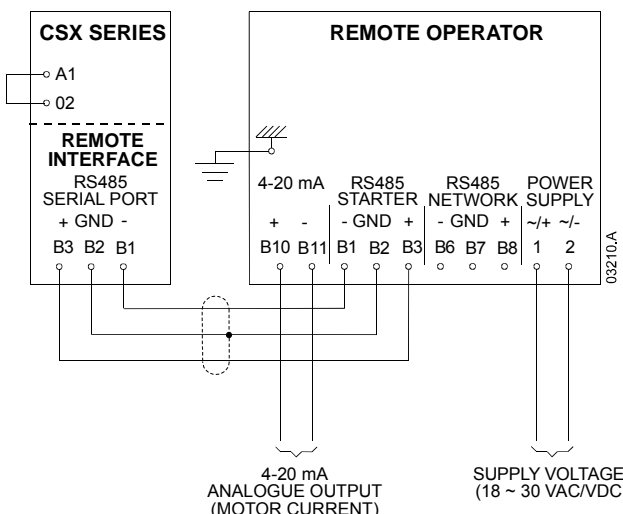

**NOTE**

For the Remote Operator to operate correctly, a link must also be made between A1 and 02 on the soft starter.

**Section 3**

**Specifications**

**3.1 General Technical Data**

<b>Enclosure</b>	
Front Panel Height .....	120 mm
Front Panel Width .....	120 mm
Inside Panel Depth (when mounted) .....	30 mm (max)
Panel Cutout .....	92 mm <sup>2</sup>
Weight .....	450 g
<b>Power Supply</b>	
Voltage .....	18 – 30 VDC/VAC (50/60 Hz)
.....	5A @ 30 VDC resistive
Consumption .....	250 mA (max)
.....	5A @ 30 VDC resistive
Connection (Terminals 1, 2) .....	2 pole spring clamp connector terminals
<b>RS485 Serial Network Port (Optional)</b>	
RS485 Network Interface .....	AP ASCII or Modbus RTU protocol (selectable)
.....	5A @ 30 VDC resistive
Connection (Terminals B6, B7, B8) .....	3 pole spring clamp connector terminals
<b>RS485 Serial Starter Port (Soft Starter Connection)</b>	
RS485 Soft Starter Interface .....	AP ASCII protocol as standard
.....	5A @ 30 VDC resistive
Connection (Terminals B1, B2, B3) .....	3 pole spring clamp connector terminals
<b>Analog Output</b>	
Motor Current Monitoring Interface .....	4 – 20 mA (max burden 200 Ω)
.....	5A @ 30 VDC resistive
Connection (Terminals B10, B11) .....	2 pole spring clamp connector terminals

Sundry	
Enclosure Rating .....	IP54 or NEMA 12 when correctly panel mounted
Pollution Degree .....	Pollution Degree 3
Operating Temperature .....	- 5 °C / + 60 °C
Relative Humidity .....	5 to 95% (max non-condensing)

This product has been designed for Class A equipment. Use of the product in domestic environments may cause radio interference, in which case the user may be required to employ additional mitigation methods.

Standards Approvals	
CE .....	IEC 60947-4-2
UL and C-UL .....	UL 508
C✓ .....	IEC 60947-4-2

### 3.2 Dimensions

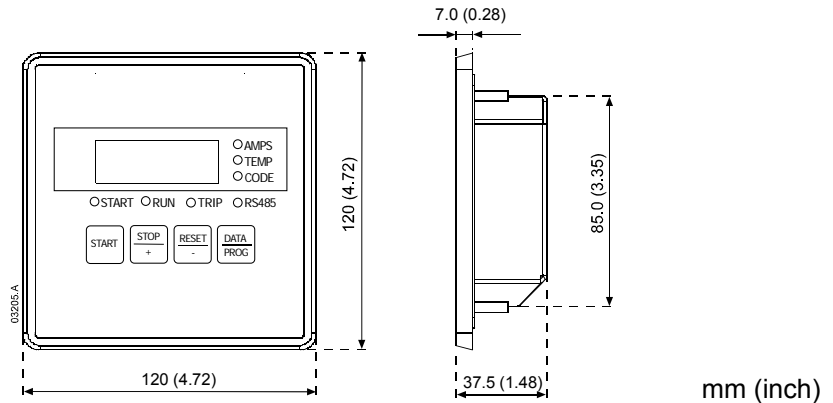

## Section 4 Operation

### 4.1 Functionality Range

The Remote Operator provides the following range of functions:

Description	CSX	CSXi	
Operational Control (Start, Stop, Reset, Quick Stop)	●	●	
Starter Status Monitoring (Ready, Starting, Running, Stopping, Tripped)	●	●	
Performance Monitoring (Motor Current, Motor Temperature)		●	
Trip Code Display	●	●	
4-20 mA Analog Output		●	

## 4.2 Operation

The Remote Operator performs all soft starter functions except programming of the soft starter. The Remote Operator can only be used to program its own user adjustable parameters. Uploading and downloading of the soft starter parameters is achieved locally at the soft starter or through the serial communications network if connected.

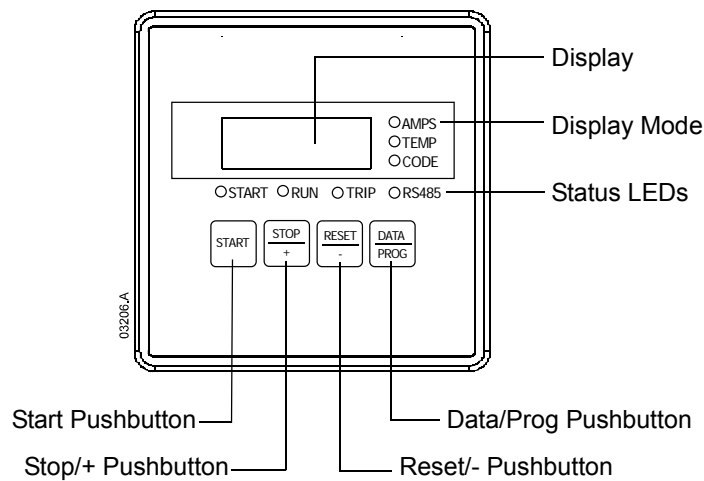

**Start Pushbutton:** Starts the motor.

**Stop/+ Pushbutton:** Stops the motor. <sup>1</sup>

**Reset/- Pushbutton:** Resets the starter. <sup>1</sup>

**Data/Prog Pushbutton:** Selects the data type to be shown on the display (Motor Current or Motor Temperature), or accesses Programming Mode.

**Display Mode:** Indicates the data type shown on the display:

- Motor Current
- Motor Temperature
- Trip Code

**Display:** Indicates the value of the selected data.

**Status LEDs:** Indicate the status of the starter, and of the RS485 link between the Remote Operator and the starter.

- The Start LED (Green) indicates that the soft starter is starting, running or stopping.
- The Run LED (Green) indicates that the soft starter is providing full voltage to the motor.
- The Trip LED (Red) indicates that the soft starter has tripped.
- The RS485 Status LED shows the condition of the serial link between the Remote Operator and the soft starter. When this is illuminated the connection is healthy. When the LED is flashing there has been loss of communication.

<sup>1</sup> Simultaneously pressing the Stop/+ and Reset/- pushbuttons initiates a quick stop, which immediately removes voltage from the motor, ignoring any soft stop time set on the starter.



### NOTE

Motor Current and Motor Temperature information is only available from CSXi starters. If connected to a CSX open loop soft starter, the display will show 2222 instead of Motor Current and 1.11 instead of Motor Temperature.

### 4.3 Trip Codes

If the soft starter trips, the relevant trip code is displayed on the Remote Operator display. The CODE and TRIP LEDs are illuminated. Some trip codes are not available from all starter models – refer to the table below.

Code	Description	CSX	CSXi	
1-1	Excess Start Time		●	
1-2	Motor Overload		●	
1-3	Motor Thermistor		●	
1-4	Phase Imbalance		●	
1-5	Supply Frequency	●	●	
1-6	Phase Sequence		●	
1-8	Power Circuit	●	●	
1-C	Communications Failure between interface and starter	●	●	
1-H	Communications Failure between interface and network	●	●	

## Section 5

### 4 – 20mA Analog

#### 5.1 Overview

The Remote Operator has a 4-20 mA Analog Output for monitoring motor current. The 4-20 mA output is available on terminals B10 and B11.

The analog output signal spans from 4 mA when the motor current is zero (ie soft starter is not running) to 20 mA when the motor current is 125% of the Motor FLC setting in the Remote Operator (Parameter 6).



#### NOTE

The 4-20 mA output is available only when the Remote Operator is connected to CSXi models.

#### 5.2 Calibration

The Remote Operator Motor FLC parameter (Parameter 6) must be adjusted to match the Motor FLC setting in the soft starter. The lower end of the analog output signal can be calibrated using the Remote Operator Analog Output 4 mA Offset parameter (Parameter 7). This is set to give a 4 mA output signal when the motor current is zero.

The 4-20 mA Analog Output must only be used for motor current monitoring and metering. It is not designed for process signal control use.

#### 5.3 Programming

When the 4-20 mA output is being used, the Remote Operator's Motor FLC and Analog Output 4 mA Offset parameters (Parameters 6 and 7) must be set to suit the application. Programming can only be carried out while the soft starter is not running.

##### Programming Procedure

- Enter Programming Mode by holding down the Data/Prog Pushbutton for four seconds. The default value of the first parameter will be displayed.
- Use the Data/Prog Pushbutton to advance to the next parameter.
- Use the Stop/+ and Reset/- pushbuttons to adjust parameter values.

Programming Mode is exited when the Data/Prog Pushbutton is pressed after Parameter 8.

**NOTE**

There is a 20 second timeout when the Remote Operator is in Programming Mode. Programming Mode will automatically close if no input is registered for 20 seconds. Any changes already made will be saved.

Parameter Number	Description	Default Setting	Adjustable Range
1	RS485 Network Baud Rate <sup>1</sup>	4	
2	RS485 Network Satellite Address <sup>1</sup>	20	
3	RS485 Network Timeout <sup>1</sup>	0	
4	RS485 Network Protocol <sup>1</sup>	1	
5	Modbus Protocol Parity <sup>1</sup>	0	
6	Motor FLC (A)	10	1 to 2868
7	Analog Output 4 mA Offset (%)	100	80 to 120
8	Start, Stop, Quick Stop function disable	0	0 = Remote Operator start, stop, quick stop function enabled. 1 = Remote Operator start, stop, quick stop function enabled. 2 = Remote Operator start, stop, quick stop function disabled. <sup>2</sup> 3 = Remote Operator start, stop, quick stop function disabled. <sup>2</sup>

<sup>1</sup> Parameters 1 to 5 are not relevant for the 4-20 mA output. Please refer to the Modbus Interface Installation Instructions for details.

<sup>2</sup> Remote Operator Reset/- Pushbutton is always enabled.

## Section 6 Troubleshooting

### 6.1 General Faults

The Remote Operator Display and Status LEDs can indicate abnormal operating or system conditions. This troubleshooting guide gives details of these conditions.

Display Indication	Problem	Possible Solution
No display	No control supply voltage	Check that correct voltage is present at terminals 1 and 2.
AMPS or TEMP LED flashing	Soft starter in restart delay mode	Wait for the restart delay (programmed in the soft starter) to elapse.
Four dashes on display and RS485 LED flashing	The Remote Operator has detected a loss of communication on the RS485 link to the soft starter	Verify and solve the cause for loss of communication. If communication is restored before the soft starter registers a Communications Failure, the display will return to active status and the RS485 LED will illuminate. If communications are restored after the soft starter registers a Communications Failure, the display will indicate a trip code. Use the Reset/- Pushbutton to reset the soft starter fault.
-	Incorrect or no 4-20 mA Analog Output signal	Check the correct voltage is present at terminals 1 and 2. Check that correct polarity is used at terminals B10 and B11. Check that the Motor FLC and Analog Output 4 mA Offset parameters are set correctly.
-	The motor cannot be started	Check that control voltage is connected to the starter. If connected to a CSX starter, check that terminals A1 and 02 are linked.