



**www.saftronics.com**

## **START-UP PROCEDURE**

### **FOR THE GP5 / FP5**

#### **TABLE OF CONTENTS**

	<b>PAGE</b>
INSTALLATION	2
EXAMPLE 1: Start/Stop & Speed Changes via the Keypad (Out of Box)	4
EXAMPLE 2: Remote Start/Stop (2-wire) & Speed Changes via Keypad	5
EXAMPLE 3: Remote Start/Stop (3-wire) & Speed changes via the Keypad	6
EXAMPLE 4: Remote Start/Stop (3-wire) & Speed Changes via a Remote Source	7
EXAMPLE 5: Remote Start/Stop (3-wire) & Speed Changes via the Speed Pot	8
EXAMPLE 6: Remote Start/Stop (2-wire) & Speed Changes via external source with 3 Present Speeds	9
ADJUSTING THE TRIM POT.	
WARNING	11

**Saftronics, Inc.**

5580 Enterprise Pkwy., Ft. Myers, FL 33905

Telephone: (941) 693-7200

Fax: (941) 693-2431

P/N 027-2073

## Start-Up Procedure for the GP5/FP5

The following procedure is to assist in the start-up of the GP5/FP5 inverter, by providing a step by step guide to installation, programming and basic operation of the GP5/FP5 inverter. The procedure is based on several common configurations used in the industry. For more detailed configurations and applications refer to the GP5/FP5 instruction manual (Part # 027-2005F) available at [www.saftronics.com](http://www.saftronics.com).

### Installation

1. Verify that the input voltage of the supply, motor and the drive model number are all marked with the same voltage. Caution: If improper voltage is applied to the inverter, severe damage will result.
2. Mount the inverter on a vertical surface with adequate space for proper air circulation (minimum 1.18 inches on each side and 4.72 inches above and below; (Instruction Manual Page 17).
3. Remove the front cover, connect conduit to the bottom plate, and connect power and ground wires to the correct terminals.  
Caution: Connect correct input voltage to terminal L1, L2, and L3.  
Connect motor to terminals T1, T2 and T3 only or severe damage will result.
4. Replace the cover and apply voltage to the inverter. The keypad will display "Frequency Ref. U- 01=0.00Hz"; *Drive*, *SEQ*, *REF* & *Stop* LED's should be illuminated on the keypad. Pressing the Local/Remote key will turn off the *SEQ* and *REF* LED's and put the inverter into local mode (keypad control). By pressing the RUN key and holding ▲ key until U-01= 6Hz is displayed, and then pressing the ENTER key, will enable you to check the rotation of the motor. If the rotation is incorrect remove power from the inverter, wait for the *Charge* LED to go out and then swap motor leads T1 and T2 and then repeat step 4 to verify the rotation is correct on the application.
5. Keypad - To access any parameter, press the DSPL key until "parameter" is displayed on the LCD readout. Use the ▲ and ▼ keys until the desired parameter is displayed then press ENTER. To change the value in the parameter simply use the ▲ and ▼ keys and press ENTER to accept that changed value. The keypad will then display END, to signify that the inverter has accepted the changes. For additional programming instructions on the keypad see the GP5/FP5 Instruction Manual, part # 027-2005F available at [www.saftronics.com](http://www.saftronics.com).

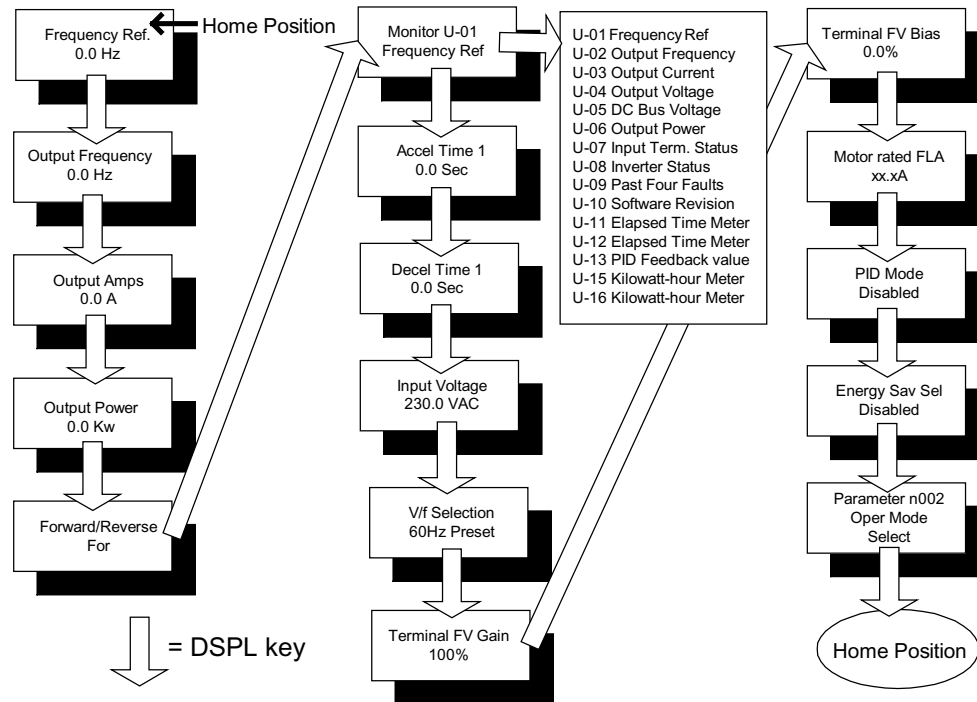

- Choose a Configuration from the table below, each example listed below contains a control wiring diagram, operation explanation, and all the necessary programming (associated with that mode). The GP5/FP5 inverter can be controlled in several more modes than explained in the start-up guide. The following configurations are generally considered the most commonly used in the field. For a more complete explanation, please refer to the GP5/FP5 Instruction Manual part # 027-2005F or download a copy from our website, www.saftronics.com.

**Table A: Inverter Configuration Examples**

Sequence (Start/Stop)	Reference (Speed Changes)	Description	Example Page
Keypad	Keypad	No control wiring needed to perform initial start-up and check rotation of the motor.	Example 1 Page 2
2-wire	Keypad	Start/Stop via the remote contact (PLC), speed changes via the keypad .	Example 2 Page 3
3-wire	Keypad	Start/Stop via the remote pushbuttons, speed changes via the keypad.	Example 3 Page 4
2-wire	4 to 20mA	Start/Stop and speed changes from a remote source such as a PLC.	Example 4 Page 6
3-wire	0 to 10Vdc (Speed Pot.)	Start/Stop via the remote pushbuttons, speed changes via a remote speed pot. or external source (0 to 10Vdc).	Example 5 Page 7
2-wire	Contact Closures	Start/Stop via the remote contact (PLC) and speed changes via present speeds or analog reference.	Example 6 Page 9

- Control Terminal Wiring- Remove power and wait until the *Charge* LED goes out before making control connections. The size of the control wiring should be between 16AWG and 20AWG wire. All control wiring should be shielded, with the shield grounded to the inverter's chassis ground and the other end left unconnected. All the control wiring terminates on the terminal strip located on the control card (the card that plugs into the keypad).

### **Example 1: Start/Stop & Speed Changes via the Keypad (Out of Box)**

When the inverter is set up with the sequence (start/stop) and the reference (speed changes) via the keypad, that is considered local mode. Local mode is generally used during initial start up or to check the rotation of the motor. The inverter can be easily put in into local mode by pressing the LOCAL/REMOTE key. When the inverter is in local mode the *SEQ* and *REF* LED's are not illuminated on the keypad. If power is removed and then restored, the inverter will come up in remote mode (*SEQ* and *REF* LED's are illuminated).

**Note:** *The inverter can be placed in local mode by changing the programming (N002= SEQ-OPR , REF-OPR). For a more detailed explanation, refer to the Instruction Manual (Page 37 part # 027-2007F).*

### **Operation**

The frequency ref.(speed change) is programmed into parameter U-01 (Frequency Ref.).

The inverter can be started by pressing the RUN key on the keypad.

The inverter can be stopped by pressing the STOP key on the keypad.

The direction of the motor can be changed, regardless of the motor speed, by pressing the DSPL key until Forward/Reverse is shown on the LCD readout, and then use the **▲** key to change the value, then press the ENTER key to change the direction of the motor.

**Table 1: Programming needed for Local Mode (Keypad control)**

Parameter	Display Text	Description
N002	Oper Mode Select SEQ=OPR REF=OPR	Sets the frequency via the keypad and sets the start/stop via the keypad.
N018/19	Accel Time Decel Time	Acceleration Time and Deceleration Time/ From stop to full speed.
N033	Motor Rated FLA N033= X.XA	Enter Full load amps from the motor nameplate data (This sets the motor protection level).
Frequency Ref.	Frequency Ref U1-01=XX.Hz	Sets the desired frequency reference (speed). Settable by pressing DATA/ENTER. Use the <b>▲</b> and <b>▼</b> arrow keys to set the frequency and then press DATA/ENTER.
Forward/Reverse	Forward/Reverse For	With this display, the motor direction can be changed regardless of motor speed.

**Note:** *After the changes are made, the DRIVE, SEQ and STOP LED's will be lit.*

### Example 2: Remote Start/Stop (2-wire) & Speed Changes via Keypad

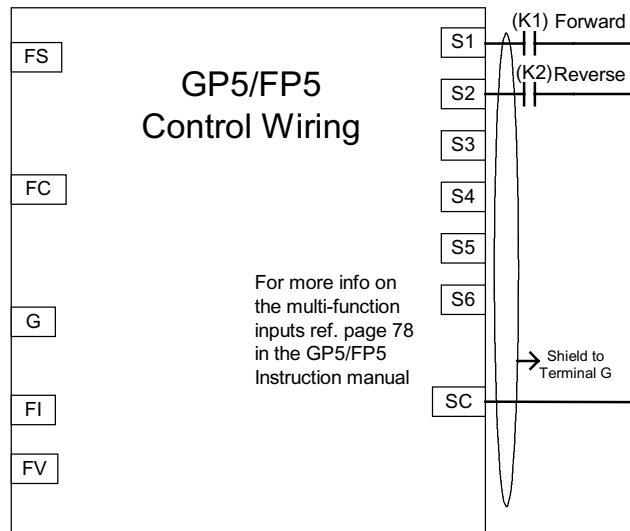

This configuration is used when the Start/Stop is via an external source such as a PLC or relay. It can also be used with a maintained switch when it is desirable to have the inverter restart on the return of power. It should not be used where the safety of personnel might be threatened by the restart of the machine.

#### Operation

Frequency reference (speed change) is programmed into parameter U-01 ( see table 2 for details).

Close (K1) to run in the forward direction at the speed set in U-01.

Close (K2) to run in the reverse direction at the speed set in U-01.

When both relays (input) are closed, the inverter will display an EF (External Fault) error.

When the LOCAL/REMOTE key is pressed, the inverter will act as Example 1.

**Table 2: Programming needed for remote Start/Stop (2-wire) and Speed Changes via the Keypad**

Parameter	Display	Description
N001	Password 8	The inverter will perform a 2-wire reset. CAUTION: This parameter sets all parameters to their factory settings and all previous settings will be lost. When the inverter completes the reset, the parameter returns to a value of 1.
N001	Password 3	Change to a value of 3 to access all parameters in the inverter.
N002	Oper Mode Select SEQ=OPR REF=OPR	Sets the frequency via the keypad and sets the start/stop via the keypad.
FLA	Motor Rated FLA x.x A	Enter the full load amps from the motor nameplate (this sets the motor protection level).
U1-01	Frequency Ref U-01=XX.Hz	Sets the desired frequency reference (speed). Settable by pressing DATA/ENTER. Use the ^ and v arrow keys to set the frequency and then press DATA/ENTER.
Forward/ Reverse	Forward/Reverse For	With this display, the motor direction can be changed regardless of motor speed.

**Note:** After the changes are made, the DRIVE, SEQ and STOP LED's will be lit.

### Example 3: Remote Start/Stop (3-wire) & Speed changes via the Keypad

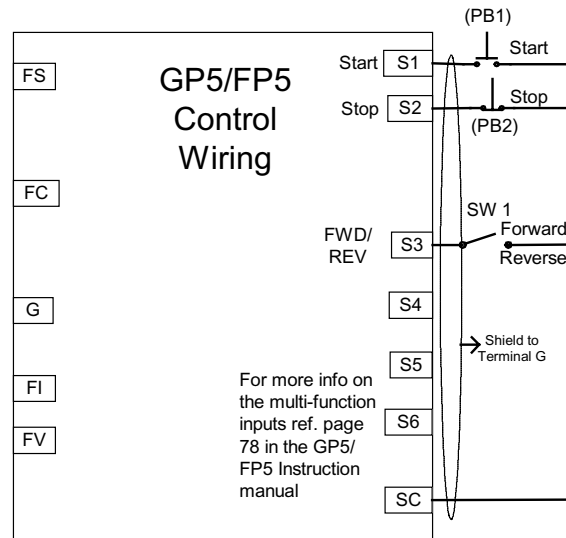

This mode is commonly used when an inverter is replacing existing equipment such as an across the line starter and the application requires minimal to no speed changes.

### Operation

The frequency reference (speed change) is programmed into parameter U-01.

By momentarily closing push-button (PB1), while push-button (PB2) is closed, the inverter will run up to the frequency reference set into U-01.

By opening push-button (PB2) at any time, the inverter will stop.

When switch (SW1) is in the open position the motor will run in the forward direction. If the switch (SW1) is closed, the motor will reverse direction.

When the LOCAL/REMOTE key is pressed, the inverter will act as Example 1.

**Table 3: Programming Needed for Start/Stop (3-wire) and Speed Changes via the Keypad**

Parameter	Display	Description
N001	Password 9	The inverter will perform a 3-wire reset CAUTION: This parameter sets all parameters to their factory settings and all previous settings will be lost. When the inverter completes the reset, the parameter returns to a value of 1.
N001	Password 3	Change to a value of 3, to access all parameters in the inverter.
N002	Oper Mode Select SEQ=TRM REF=OPR	Sets the frequency via the keypad and sets the start/stop via remote start/stop push-buttons.
FLA	Motor Rated FLA x.x A	Enter the full load amps from the motor nameplate. (this sets the motor protection level)
U1-01	Frequency Ref U-01=XX.Hz	Sets the desired frequency reference (speed). Settable by pressing DATA/ENTER. Use the ▲ and ▼ arrow keys to set the frequency and then press DATA/ENTER.

### Example 4: Remote Start/Stop (3-wire) & Speed Changes via a Remote Source

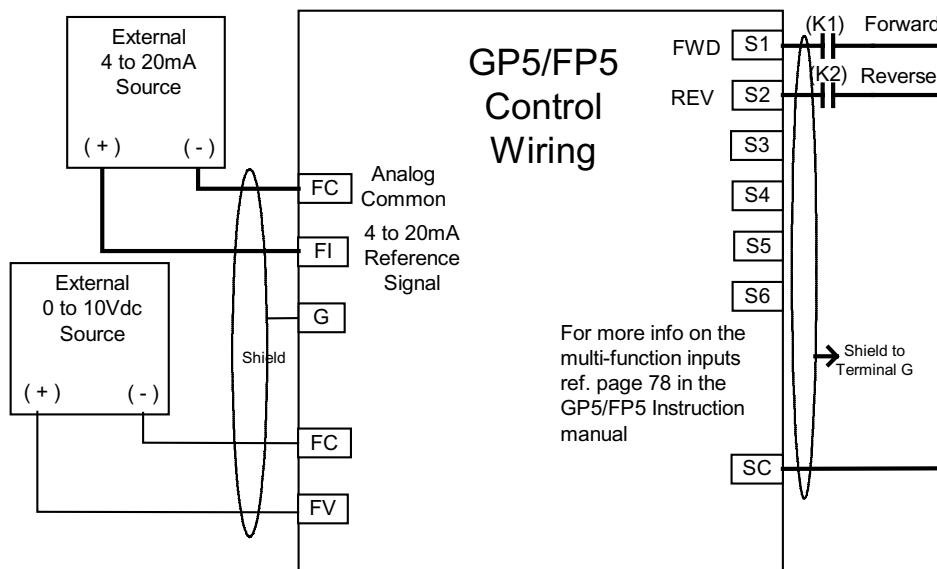

This configuration is used when the start & stop signals and the speed changes originate from a remote source such as a controller or PLC. It can also be used with a maintained switch, when it is desirable to have the drive restart on restoration of power. It should not be used where the safety of the attending personnel might be threatened by the automatic restart of the motor.

#### Operation

Close (K1) to run in the forward direction.

Close (K2) to run in the reverse direction.

When both relays are closed the inverter will fault on a External Fault and stop operation of the motor.

The frequency of the inverter will be proportional to the signal level on terminal FI ( 4mA=0Hz  
12mA=30Hz & 20mA =60Hz).

When the LOCAL/REMOTE key is pressed, the inverter will act as Example 1.

**Table 4: Programming needed for remote Start/Stop (2-wire) with 4 to 20mA signal for Speed Changes**

Parameter	Display	Description
N001	Password 8	The inverter will perform a 2-wire reset. CAUTION: This parameter sets all parameters to their factory settings and all previous settings will be lost. When the inverter completes the reset, the parameter returns to a value of 1.
N001	Password 3	Change to a value of 3, to access all parameter in the inverter.
N018/19	Accel Time Decel Time	Acceleration Time and Deceleration Time/ From stop to full speed.
N043	AnalogInput Sel FV=AUX FI =MSTR	This parameter sets terminal FI to be the master frequency reference or FV as the master from master frequency reference.
N033	Motor Rated FLA x.x A	Enter the full load amps from the motor nameplate (this sets the motor protection level).

**Note:** After the changes are made, the DRIVE, SEQ and STOP LED's will be lit.

### Example 5: Remote Start/Stop (3-wire) & Speed Changes via the Speed Pot

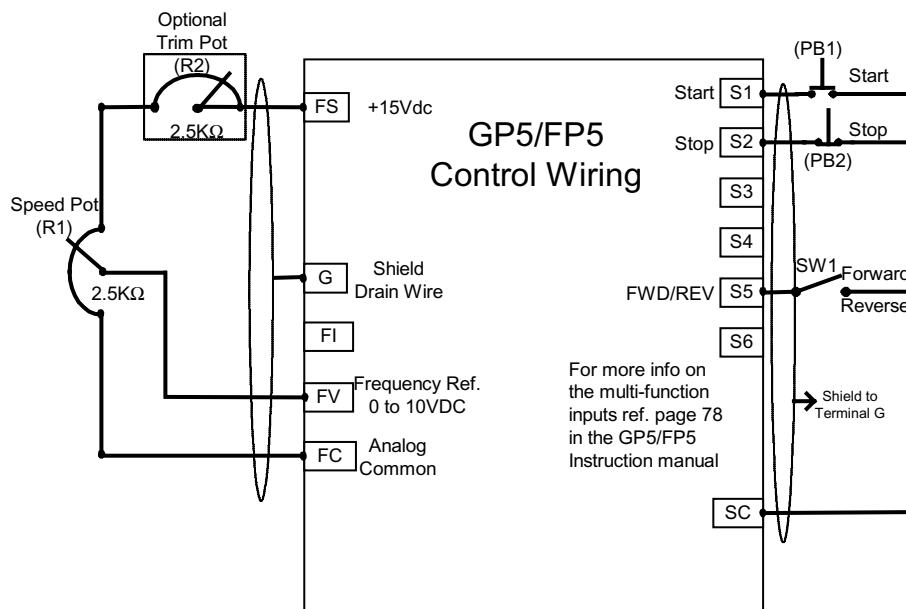

This configuration is best utilized when a person has control of the inverter and the application. Both potentiometers should be rated between 2kΩ and 5kΩ of resistance and rated at least 1/4 watt each. The trim pot. is optional, but without it the manual speed pot. will run the inverter at full speed when the pot is only turned 2/3 of a full turn.

### Operation

By momentarily closing push-button (PB1), while push-button (PB2) is closed, the inverter will run up to the frequency (speed) set into U-01 Frequency Ref..

By opening push-button (PB2) at any time, the inverter will stop.

When switch (SW1) is in the open position the motor will run in the forward direction. If the switch (SW1) is closed, the motor will reverse direction.

The frequency reference (speed) is proportional to the signal level present on terminal FV  
0V=0Hz, 5V=30Hz and 10V=60Hz.

When the LOCAL/REMOTE key is pressed, the inverter will act as Example 1.

**Table 5: Programming needed for Remote (3-wire) & Speed Changes via Speed Potentiometer**

Parameter	Display	Description
N001	Password 8	The inverter will perform a 2-wire reset. CAUTION: This parameter sets all parameters to their factory settings and all previous settings will be lost. When the inverter completes the reset, the parameter returns to a value of 1.
N001	Password 3	Change to a value of 3, to access all parameter in the inverter.
N018/19	Accel Time Decel Time	Acceleration Time and Deceleration Time/ From stop to full speed.
N033	Motor Rated FLA x.x A	Enter the full load amps from the motor nameplate (this sets the motor protection level).

**Note:** After the changes are made, the DRIVE, SEQ and STOP LED's will be lit.

### Example 6: Remote Start/Stop (2-wire) & Speed Changes via external source with 3 Present Speeds

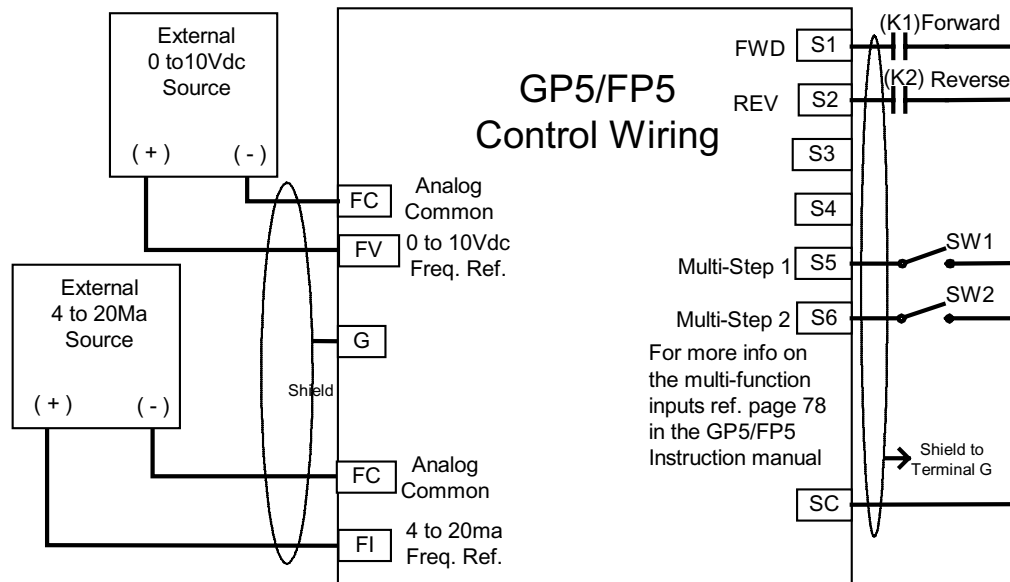

This configuration is generally used when the inverter is controlled via a remote source such as a PLC. It can also be used with a maintained switch when it is desirable to have the drive restart on restoration of power. It should not be used where the safety of the attending personnel might be threatened by automatic restart. Up to three speeds can be selected by using the switches SW1-SW2 to select the desired speed.

#### Operation

Close (K1) to run in the forward direction.

Close (K2) to run in the reverse direction.

When both relays are closed, the inverter will fault on a External Fault and stop operation of the motor.

The frequency of the inverter will be proportional to the signal level on terminal FV or FI (0Vdc=0Hz, 5Vdc=30Hz & 10Vdc =60Hz).

By closing any of the switches (SW1-SW2) and closing either (K1) or( K2) to determine the direction, the inverter will run at a present speed.

When the LOCAL/REMOTE key is pressed, the inverter will act as Example 1.

**Table 6: Programming needed for Remote Start/Stop (2-wire) & Multiple Inputs for Speed Changes**

Parameter	Display	Description
N001	Password 8	The inverter will perform a 2-wire reset. CAUTION: This parameter sets all parameters to their factory settings and all previous settings will be lost. When the inverter completes the reset, the parameter returns to a value of 1.
N001	Password 3	Change to a value of 3, to access all parameter in the inverter.
N018/19	Accel Time Decel Time	Acceleration Time and Deceleration Time/ From stop to full speed.
N025	Reference 2 X.X Hz	Sets the Frequency Reference (speed) when SW1 is closed and SW2 is open.
N026	Reference 3 X.X Hz	Sets the Frequency Reference (speed) when SW2 is closed and SW1 is open.
N027	Reference 4 X.X Hz	Sets the Frequency Reference (speed) when SW1 and SW2 are closed.
N033	Motor Rated FLA x.x A	Enter the full load amps from the motor nameplate (this sets the motor protection level).

**Table 7 : Truth Table for Present Speeds**

SW1 Status	SW2 Status	Reference Source
Open	Open	Analog value present on Terminal FV
Closed	Open	Frequency stored in Parameter N025
Open	Closed	Frequency stored in Parameter N026
Closed	Closed	Frequency stored in Parameter N027

### Adjusting the Trim pot.

Turn the main speed pot. all the way up (fully clockwise), then adjust the trim pot. until the frequency ref. display drops below 60Hz. That completes the calibration of the trim pot..

**Notes:**     Underlined words indicate a key on the keypad.  
*Italic words indicate an LED on the keypad.*

---

**WARNING!**

*Saftronics* manufactures component parts that can be used in a wide variety of industrial applications. The selection and application of *Saftronics* products remains the responsibility of the equipment designer or end user. *Saftronics* accepts no responsibility for how its products may be incorporated into the final design.

Under no circumstances should any *Saftronics* product be incorporated into any product or design as the exclusive or sole safety control. Without exception, all controls should be designed to dynamically fault detect and fail safe under all circumstances. All products designed to incorporate a component part manufactured by *Saftronics*, must be supplied to the end user with appropriate warnings and instructions as to the safe use and operation. Any warnings provided by *Saftronics* must be passed through to the end user.

*Saftronics* offers an express warranty only as to the quality of its products to conform to the catalog specifications. **NO OTHER WARRANTY EXPRESS OR IMPLIED IS OFFERED.** *Saftronics* assumes no liability for any personal injury, property damage, losses or claims, arising out of the misapplication of its products.

For more info visit [www.saftronics.com](http://www.saftronics.com)