



VM7

INSTRUCTION MANUAL



I.	Thank You!	1
II.	Safety/Hazards	1
III.	Waiver of Liability	2
IV.	Copyright	2
V.	Introduction	2
VI.	About This Manual	3
VII.	If You Have Difficulty	3
VIII.	Product Overview	4
IX.	Standard Features	4
X.	CE Marking	5
XI.	Model Numbers	6
XII.	Product Specifications	7

Chapter 1: Installation

1.0	Receiving	1-2
1.1	Assess the Environment	1-3
1.2	Positioning	1-3
1.3	Dimensions	1-4
1.4	Heat Dissipation	1-4

Chapter 2: Quickstart

2.0	Pre-Power Checks	2-2
2.1	Operating the Inverter	2-3
2.2	Operating the Digital Operator	2-4
2.3	LED Description	2-7
2.4	Monitoring	2-9
2.5	Setting and Referring Constants	2-10
2.6	Simple Data Setting	2-11

Chapter 3: Wiring

3.0	General Precautions	3-2
3.1	Power Wiring	3-4
3.1.1	Power Wiring Precautions	3-4
3.1.2	Input Protection	3-6
3.1.3	Wire Selection Recommendations	3-7
3.1.4	Power Interconnect Wiring	3-8
3.2	Control Wiring	3-9
3.2.1	Control Wiring Precautions	3-9
3.2.2	Terminal Locations	3-9
3.2.3	Control Terminal Layout	3-10
3.2.4	Terminal Definitions	3-11
3.2.5	Standard I/O Wiring	3-12
3.3	Grounding	3-13

Chapter 4: Programming

4.0	Programming	4-2
4.1	Keypad Layout	4-2
4.2	Key Functions	4-2
4.2.1	Display Key	4-3
4.2.2	Up/Down Arrows	4-3
4.2.3	Basic LED Description	4-4
4.2.4	Switching Local/Remote Modes	4-5
4.2.5	Selecting Run/Stop Commands	4-6
4.2.6	Selecting Frequency Reference	4-7
4.3	First Functions	4-10
4.3.1	Constant Set-Up and Initialization	4-10
4.3.2	When Torque is not Sufficient at Low Speed	4-12
4.3.3	Using V/f Mode	4-12
4.3.4	Decreasing Motor Speed Fluctuation	4-16
4.3.5	Selecting Run/Stop Commands	4-17
4.3.6	Selecting Frequency Reference	4-18

4.3.7	Selecting Frequency by Current Reference Input	4-20
4.3.8	Selecting Stopping Method	4-23
4.3.9	Setting Reverse Run Prohibit	4-24
4.3.10	Operator Stop Key Selection	4-24
4.3.11	Using Two Accel/Decel Times	4-25
4.3.12	Soft-Start Characteristics	4-26
4.3.13	Setting Preset Speeds	4-27
4.3.14	Operating at Low Speed	4-28
4.3.15	Adjusting Frequency Upper/Lower Limits	4-29
4.3.16	Motor Protection	4-29
4.3.17	Selecting Cooling Fan Operation	4-31
4.4	Second Functions	4-32
4.4.1	Building Interface Circuits with External Devices	4-32
4.4.2	Adjusting Frequency Reference Signal	4-36
4.4.3	Using Frequency Meter or Ammeter	4-38
4.4.4	Reducing Motor Noise or Leakage Current	4-39
4.4.5	Auto-Restart After Momentary Power Loss	4-41
4.4.6	Continuing Operation by Auto-Fault Reset	4-41
4.4.7	Jump Frequencies	4-42
4.4.8	Applying DC Injection Braking	4-42
4.4.9	Stall Prevention During Decel	4-43
4.4.10	Preventing Motor From Stalling	4-44
4.4.11	Stall Prevention During Run	4-45
4.4.12	Frequency Detection	4-46
4.4.13	Torque Detection	4-47
4.4.14	Time Chart at Up/Down Command Input	4-48
4.4.15	Holding Accel/Decel Temporarily	4-49
4.4.16	Using MODBUS Communications	4-51
4.4.17	Using Constant Copy Function	4-52

Table of Contents

Chapter 5: PM/Troubleshooting

5.0	Periodic Inspection	5-2
5.1	Operational Faults	5-2
5.2	Alarm and Fault Codes	5-6

Appendix A: Parameter List

First Functions (n01 to n35)	A-2
Second Functions (n36 to n79)	A-3

I. THANK YOU!

We at Safronics appreciate your purchase of this VM7 model adjustable frequency drive. When properly installed, operated, and maintained, this unit will provide a lifetime of reliable, troublefree operation.

This manual was written to serve as a tool for *qualified* personnel to use in the installation, programming, and troubleshooting of this equipment. It is **IMPORTANT** the installer thoroughly read and understand the information contained herein before any action is taken.

This document is organized via numbered chapters, which should be read in sequence before any work is performed.

II. SAFETY/HAZARDS



The safety of personnel is of utmost importance to Safronics, Inc. This symbol is used throughout this manual to identify specific hazards which can lead to personal injury, death, property damage or economic loss. The applicable procedures must be performed only by qualified personnel who have been instructed with respect to the hazards involved with potentially lethal voltages.

III. WAIVER OF LIABILITY

No patent liability is assumed with respect to the use of the information contained herein. Moreover, because we at Safronics are constantly improving our high quality products, the information contained in this manual is subject to change without notice. Every precaution has been taken in the preparation of this manual. Nevertheless, Safronics assumes no responsibility for errors or omissions. Neither is any liability assumed for damages resulting from the use of the information contained in this publication. In no event will Safronics be responsible or liable for indirect or consequential damages resulting from the use or application of this equipment.

IV. COPYRIGHT

© 2000 Safronics, Inc. All rights reserved. The information contained herein is the proprietary property of Safronics, Inc., and may not be copied, reproduced or transmitted to other parties without the expressed written consent of Safronics, Inc.

V. INTRODUCTION

The VM7 is a high performance, microprocessor-based AC motor speed controller. Its inherent programming and mechanical flexibility make it the *ultimate* general purpose inverter, for distributor and OEM alike. It is available as a protected chassis. The ultra-compact protected chassis units are available through 5HP at 230V and through 5HP at 460V. (see notes on product specifications)

VI. ABOUT THIS MANUAL

This document will serve as the installation, programming and troubleshooting manual for the VM7 Micro AC Drive. It must be read in its entirety before any installation or troubleshooting is performed. This manual should be followed in sequence, starting with Chapter 1. The chapters are organized as follows:

Chapter 1:	Installation
Chapter 2:	Quickstart
Chapter 3:	Wiring
Chapter 4:	Programming
Chapter 5:	PM & Troubleshooting

The VM7 adjustments are made through a family of programming parameters which have a number designator. By convention, this manual will print the **FUNCTION** numbers in bold to highlight them.

VII. IF YOU HAVE DIFFICULTY

Please reread the applicable sections of this manual. If you still have difficulty, contact your local distributor or authorized representative. If they are unable to answer your questions, please contact Safronics technical support by phone at 941-693-7200 or by fax at 941-693-2431. Before you contact the factory, make sure you have the unit model number, serial number, program data and wiring diagram available. Your cooperation will help us serve you promptly and efficiently.

VIII. PRODUCT OVERVIEW

The VM7 was designed as a compact, yet powerful platform to handle a wide variety of general purpose applications. This product uses the latest in microprocessor technology to provide a precise, reliable controller for three-phase AC motors.

The VM7 can be used with a single phase input, but must always be used with 3 phase AC motors. Consult with the factory for special input power requirements.

The VM7 has programmable I/O and will satisfy a wide variety of applications. This allows the product to suit the requirements of the user, distributor, or OEM.

IX. STANDARD FEATURES:

- Latest generation of power device technology
- Compact physical size
- High carrier frequency (low noise) without derate
- Keypad is standard
- Single-phase operation without unit derate
- Programmable I/O
- Fan ventilated design (no cooling fans)
- Keypad for storage of program
- RS-485 communications port is standard
- DC injection braking & DB transistor are included
- Designed to meet requirements of CE
- Meets requirements of cUL
- 400 Hz maximum output
- Comprehensive keypad displays
- 4 fault memory (nonvolatile to retain even after power removal)
- Comprehensive ground fault protection

X. CE MARKING

This product complies with the low voltage directive (73/23/EEC), the generic standard for industrial immunity (EN50081-2) and the CE marking directive (93/68/EEC). The VM7 also complies with the Electromagnetic Compatibility (EMC) Directive (89/336/EEC). when the following requirements for a conforming installation are applied:

- ☑ An input RFI filter must be installed to limit conducted emissions
- ☑ The controller must be mounted in an electromagnetically shielded enclosure to reduce radiated emissions. A typical NEMA or IEC metal enclosure is adequate provided there are no vents and the seams are continuously welded.
- ☑ The motor cables should be shielded cable or in metal conduit to attenuate radiated emissions
- ☑ Motor cable length must be kept as short as possible

Please Note: *The conformity of the VM7 controller and any applicable filters does not necessarily guarantee that the entire installation will conform. Many installation specific factors (wire routing, proper grounding, etc.) can influence the total installation and only direct measurements can ensure total conformity.*

XI. MODEL NUMBERS

Table 0.1: Model Numbers

Input Voltage	Model Number 3-Phase (Single-Phase)	Horsepower (kW)	Rated Output Current
3-Phase 200 - 230V (Single-Phase) 200-240V	VM720P1 (B0P1)	0.13 (.01)	0.8
	VM720P2 (B0P2)	0.25 (0.2)	1.6
	VM720P4 (B0P4)	0.50 / 0.75 (0.4)	3
	VM720P7 (B0P7)	1.0 (0.75)	5
	VM721P5 (B1P5)	2.0 (1.5)	8
	VM722P2	3.0 (2.2)	11
	VM723P7*	5.0 (3.7)	17.5
3-Phase 380V - 460V	VM740P2	0.50 (0.2)	1.2
	VM740P4	0.75 / 1.0 (0.4)	1.8
	VM740P7	1.5 / 2.0 (0.75)	3.4
	VM741P5	3.0 (1.5)	4.8
	VM742P2	3.0 (2.2)	5.5
	VM743P7	5.0 (3.7)	9.2

*Under Development

XII. PRODUCT SPECIFICATIONS: 230V

Voltage Class		230V Single- / 3-Phase						
Model VM7-XXXX	3-Phase	20P1	20P2	20P4	20P7	21P5	22P2	23P7*
	Single-Phase	B0P1	B0P2	B0P4	B0P7	B1P5	-	-
Max. Applicable Motor Output kW (HP)†		0.1 (0.13)	0.2 (0.25)	0.55 (0.5)	1.1 (1)	1.5 (2)	2.2 (3)	3.7 (5)
Output Characteristics	Inverter Capacity (kVA)	0.3	0.6	1.1	1.9	3.0	4.2	6.7
	Rated Output Current (A)	0.8	1.6	3	5	8	11	17.5
	Max. Output Voltage (V)	3-Phase, 200 to 230V (proportional to input voltage) Single-Phase, 200 to 240V (proportional to input voltage)						
	Max. Output Frequency (Hz)	400 Hz (programmable)						
Power Supply	Rated Input Voltage and Frequency	3-Phase, 200 to 230V, 50/60Hz Single-Phase, 200 to 240V, 50/60Hz						
	Allowable Voltage Fluctuation	-15 to +10%						
	Allowable Frequency Fluctuation	± 5%						
Control Characteristics	Control Method	Sine Wave PWM (V/f control)						
	Frequency Control Range	0.1 to 400Hz						
	Frequency Accuracy (Temperature Change)	Digital Reference: ±0.01% (-10 to +50°C) Analog Reference: ±0.5% (25 ±10°C)						
	Frequency Setting Resolution	Digital Reference: 0.1Hz (less than 100Hz)/1Hz(100Hz or more) Analog Reference: 1/1000 of max. output frequency						
	Output Frequency Resolution	0.01Hz						
	Overload Capacity	150% rated output current for one minute						
	Frequency Reference Signal	0 to 10VDC (20kΩ), 4 to 20mA (250Ω), 0 to 20mA (250Ω), frequency setting volume (selectable)						
	Accel/Decel Time	0.1 to 999 sec. (accel/decel time are independantly programmed)						
	Braking Torque	Short-term average deceleration torque‡ 0.1, 0.25kW (0.13HP, 0.25HP): 150% 0.55, 1.1kW (0.5HP, 1HP): 100% 1.5kW (2HP): 50% 2.2kW (3HP) or more: 20% Continuous regenerative torque: Approx. 20%						
V/f Characteristics	Possible to program any V/f pattern							

*Under Development

PRODUCT SPECIFICATIONS: 230V

Voltage Class		230V Single / 3-Phase						
Model VM7-XXXX	3-Phase	20P1	20P2	20P4	20P7	21P5	22P2	23P7*
	Single-Phase	B0P1	B0P2	B0P4	B0P7	B1P5	-	-
Protective Functions	Motor Overload Protection	Electronic thermal overload relay						
	Instantaneous Overcurrent	Motor coasts to a stop at approx. 200% of inverter rated current						
	Overload	Motor coasts to a stop after 1 minute at 150% of inverter rated output current						
	Overvoltage	Motor coasts to a stop if DC bus voltage exceed 410V						
	Undervoltage	Stops when DC bus voltage is approx. 200V or less (approx. 160V or less for single-phase series)						
	Momentary Power Loss	Following items are selectable: Not provided (stops if power loss is 15ms or longer), continuous operation if power loss is approx. 0.5s or shorter, continuous operation						
	Cooling Fin Overheat	Protected by electronic circuit						
	Stall Prevention Level	Can be set individual level during accel/decel, provided/not provided available during coast to a stop						
	Cooling Fan Fault	Protected by electronic circuit (fan lock detection)						
	Ground Fault	Protected by electronic circuit (rated output current level)						
Other Functions	Power Charge Indication	ON until the DC bus voltage becomes 50V or less. RUN lamp stays ON or digital operator LED stays ON. (Charge LED is provided for 400V)						
	Input	Multi-Function Input	Four of the following input signals are selectable: reverse run (3-wire sequence), fault reset, external fault (NO/NC contact input), multi-step speed operation, Jog command, accel/decel time select, external baseblock (NO/NC contact input), speed search command, accel/decel hold command, LOCAL/REMOTE selection, communication/control circuit terminal selection, emergency stop fault emergency stop alarm					
	Output Signals	Multi-Function Output	Following output signals are selectable (1 NO/NC contact output) Fault, running, zero speed, at frequency, frequency detection (output frequency \leq or \geq set value), during overtorque detection, during undervoltage detection*, minor error, during baseblock, operation mode, inverter run ready, during fault retry, during UV, during speed search, data output through communication					
	Standard Functions		Full range automatic torque boost, slip compensation, DC injection braking current/time at start/stop (frequency reference bias/gain, MEMOBUS communications (RS-485/422, max. 19.2K bps) (optional)					

*Under Development

PRODUCT SPECIFICATIONS: 230V

Voltage Class			230V Single-/3-Phase						
Model VM7-XXXX	3-Phase		20P1	20P2	20P4	20P7	21P5	22P2	23P7*
	Single-Phase		B0P1	B0P2	B0P4	B0P7	B1P5	-	-
Other Functions	Display	Status Indicator (LED)	RUN and ALARM provided as standard LED's						
		Digital Operator	Available to monitor frequency reference, output frequency, output current						
	Terminals		Main circuit: screw terminals Control circuit: plug-in screw terminal						
	Wiring Distance between Inverter and Motor		100m (328ft or less)						
Enclosure			Open chassis						
Cooling Method			Cooling fan is provided for 200V, 0.75kW (3-/single-phase), 400V, 1.5kW (3-phase), others are self-cooling						
Environmental Conditions	Ambient Temperature		Open Chassis: -10 to +50°C (14 to 122°F) (not frozen)						
	Humidity		95% RH or less (non-condensing)						
	Storage Temperature**		-20 to +60°C (-4 to 140°F)						
	Location		Indoor (free from corrosive gases or dust)						
	Elevation		1000m (3280ft) or less						
	Vibration		Up to 9.8 / S ² (1G) at less than 20Hz, Up to 2m / S ² (0.2G) at less than 20 to 50Hz						

* Under Development

** Temperature during shipping (for short period)

† Based on a standard 4-pole motor for max. applicable motor output

‡ Shows deceleration torque for uncoupled motor decelerating from 60Hz with the shortest possible deceleration time.

PRODUCT SPECIFICATIONS: 460V

Voltage Class		460V 3-Phase					
Model VM7-XXXX	3-Phase	40P2	40P4	40P7	41P5	42P2	43P7
Max. Applicable Motor Output kW(HP)		0.37 (0.5)	0.55 (0.75)	1.1 (1.5)	1.5 (2)	2.2 (3)	3.7 (5)
Output Characteristics	Inverter Capacity (kVA)	0.9	1.4	2.6	3.7	4.2	7.0
	Rated Output Current (A)	1.2	1.8	3.4	4.8	5.5	9.2
	Max. Output Voltage (V)	3-phase, 380 to 460V (proportional to input voltage)					
	Max. Output Frequency (Hz)	400Hz (programmable)					
Power Supply	Rated Input Voltage and Frequency	3-phase, 380 to 460V, 50/60Hz					
	Allowable Voltage Fluctuation	-15 to +10%					
	Allowable Frequency Fluctuation	±5%					
Control Characteristics	Control Method	Sine wave PWM (V/f control)					
	Frequency Control Range	0.1 to 400Hz					
	Frequency Accuracy (Temperature Change)	Digital reference: ±0.01%, -10 to + 50°C (14 to 122°F) Analog reference: ±0.5%, 25± 10°C (59 to 95°F)					
	Frequency Setting Resolution	Digital reference: 0.01Hz (less than 100Hz)/0.1Hz (100Hz or more) Analog reference: 1/1000 of max. output frequency					
	Output Frequency Resolution	0.01Hz					
	Overload Capacity	150% rated output current for one minute					
	Frequency Reference Signal	0 to 10VDC (20kΩ), 4 to 20mA (250Ω), 0 to 20mA (250Ω), frequency setting volume (selectable)					
	Accel/Decel Time	0.01 to 999 sec. (accel/decel time are independently programmed)					
	Braking Torque	Short-term average deceleration torque‡ 0.2kW: 150% 0.75kW: 100% 1.5kW (2HP): 50% 2.2kW (3HP) or more: 20% Continuous regenerative torque: Approx. 20% (150% with optional braking resistor, braking transistor built-in)					
V/f Characteristics	Possible to program any V/f pattern						

PRODUCT SPECIFICATIONS: 460V

Voltage		460V 3-Phase						
Model VM7-XXXX	3-Phase	40P2	40P4	40P7	41P5	42P2	43P7	
Protective Functions	Motor Overload Protection		Electronic thermal overload relay					
	Instantaneous Overcurrent		Motor coasts to a stop at approx. 200% of inverter rated current					
	Overload		Motor coasts to a stop after 1 minute at 150% of inverter rated output current					
	Overvoltage		Motor coasts to a stop if DC bus voltage exceed 820V					
	Undervoltage		Stops when DC bus voltage is approx. 400V or less					
	Momentary Power Loss		Following items are selectable: Not provided (stops if power loss is 15ms or longer), continuous operation if power loss is approx. 0.5s or shorter, continuous operation					
	Cooling Fin Overheat		Protected by electronic circuit					
	Stall Prevention Level		Can be set to individual levels during accel/decel, provided/not provided available during coast to a stop					
	Cooling Fan Fault		Protected by electronic circuit (fan look detection)					
	Ground Fault		Protected by electronic circuit (rated output current level)					
Other Functions	Power Charge Indication		ON until the DC bus voltage becomes 50V or less. Run lamp says ON or digital operator LED stays ON. (Charge LED is provided for 400V)					
	Input Signals	Multi-Function Input	Four of the following input signals are selectable: Forward/Reverse run (3-wire sequence), fault reset, external fault (NO/NC contact input), multi-step speed operation, Jog command, accel/decel time select, external baseblock (NO/NC contact input), speed search command, accel/decel hold command, LOCAL/REMOTE selection, communication/control circuit terminal selection, emergency stop fault emergency stop alarm					
	Output Signals	Multi-Function Output	Following output signals are selectable (1 NO/NC contact output): Fault, running, zero speed, at frequency, frequency detection (output frequency \leq or \geq set value), during overtorque detection, during undervoltage detection*, minor error, during baseblock, operation mode, inverter run ready, during fault retry, during UV, during speed search, data output through communication					
Standard Functions		Full-range automatic torque boost, slip compensation, DC injection braking current/time at stop (50% of inverter rated current, 0.5 sec. or less), frequency reference bias/gain, MEMOBUS communications (RS-485/422, max. 19.2K bps)						

PRODUCT SPECIFICATIONS: 460V

Voltage Class		460V 3-Phase					
Model VM7-XXXX	3-Phase	40P2	40P4	40P7	41P5	42P2	43P7
Other Functions	Display	Status Indicator (LED)	RUN and ALARM provided as standard LED's				
		Digital Operator (JVOP-140)	Available to monitor frequency reference, output frequency, output current				
	Terminals		Main circuit: screw terminals Control circuit: plug-in screw terminal				
	Wiring Distance between Inverter and Motor		100m (328ft or less)				
Enclosure		Open chassis					
Cooling Method		Cooling fan is provided for 200V, 0.75kW (3-/single-phase), 200V, 0.75kW (1.5HP), others are self-cooling					
Environmental Conditions	Ambient Temperature		Open chassis: -10 to +50°C (14 to 122°F) (not frozen)				
	Humidity		95% RH or less (non-condensing)				
	Storage Temperature**		-20 to +60°C (-4 to 140°F)				
	Location		Indoor (free from corrosive gases or dust)				
	Elevation		1000m (3280ft) or less				
	Vibration		Up to 9.8m / S ² (1G) at less than 20Hz Up to 2m / S ² (0.2G) at less than 20 to 50Hz				

* Under development

** Temperature during shipping (for short period)

† Based on a standard 4-pole motor for max. applicable motor output

‡ Shows deceleration torque for uncoupled motor decelerating from 60Hz with the shortest possible deceleration time.

Chapter 1:

Installation

What this chapter tells you:

- 1) How to properly receive the VM7.
- 2) How to assess the installation environment.
- 3) How to properly mount the VM7.
- 4) The unit dimensions and heat dissipation.



You must confirm the model number and output current (HP) rating of the inverter before you apply power. Application of the wrong voltage power supply can cause unit damage.

1.0 RECEIVING

The VM7 has been subjected to demanding tests prior to shipment from Safronics' factory. To ensure proper operation and life of the equipment you must verify the model number is proper for the application. Please do the following before applying power:

- ☑ Inspect the shipping container. If damaged, you should immediately notify both Safronics and the carrier and file a claim with the carrier within 14 days of receipt of the unit.
- ☑ Verify the model number on the box (and the inverter) matches the invoice and the original purchase order.
- ☑ If you find any discrepancy, please notify either your distributor or authorized Safronics agent immediately so corrective action can be implemented.

1.1 ASSESS THE ENVIRONMENT

The selection of the proper mounting location of the VM7 is imperative to achieve maximum operating performance and reliability. These units were designed to withstand the harsh demands of industrial installations. Nevertheless, caution should be exercised to ensure the chosen environment meets the following:

- Ambient temperature: 14 to 122°F (-10 to +50°)
- Protected from rain or moisture
- Protected from corrosive gases or liquids
- Sheltered from direct sunlight
- Free from excessive mechanical vibration
- Free from radioactivity
- Free from oil sprays or splashed
- Relative humidity: 95% max, non-condensing
- Salt spray
- Dust or metallic particles in the air
- Magnetic noise: welding machines, power devices, etc.
- Combustibles: thinner, solvents, etc.

1.2 POSITIONING

Make sure there is a minimum clearance of 1.18" (30 mm) around the sides of the VM7 unit and at least 4 inches above and below it to provide effective cooling and to meet NEC wiring requirements. The unit should be installed on a flat, vertical and level surface with the heatsink ribs oriented vertically.

1.3 DIMENSIONS

The VM7 is available as a NEMA 1 unit, Table 1.1 gives the overall dimensions.

1.4 HEAT DISSIPATION

The wattage figures given in Table 1.1 should be used for evaluating enclosure size for non-ventilated NEMA 12 and NEMA 4 enclosures.

Table 1.1 VM7 Mini Vector Dimensions

Voltage Class	Capacity HP (kW)	W	H	D	W1	H1	H2	d	Weight	Heat Loss (W)			Fig.
										Heatsink	Unit	Total	
230V 3-Phase	0.13 (0.1)	2.68 (68)	5.04 (128)	2.76 (70)	2.20 (56)	4.65 (118)	0.20 (5)	M4	1.10 (0.5)	3.7	9.3	13.0	1
	0.25 (0.2)	2.68 (68)	5.04 (128)	2.76 (70)	2.20 (56)	4.65 (118)	0.20 (5)	M4	1.10 (0.5)	7.7	10.3	18.0	1
	0.5 (0.4)	2.68 (68)	5.04 (128)	4.02 (102)	2.20 (56)	4.65 (118)	0.20 (5)	M4	1.77 (0.8)	15.8	12.3	28.1	1
	1 (0.75)	2.68 (68)	5.04 (128)	4.80 (122)	2.20 (56)	4.65 (118)	0.20 (5)	M4	1.98 (0.9)	28.4	16.7	45.1	1
	2 (1.5)	4.25 (108)	5.04 (128)	5.08 (129)	3.78 (96)	4.65 (118)	0.20 (5)	M4	2.96 (1.3)	53.7	19.1	72.8	2
	3 (2.2)	4.25 (108)	5.04 (128)	6.06 (154)	3.78 (96)	4.65 (118)	0.20 (5)	M4	3.31 (1.5)	60.4	34.4	94.8	2
	5 (3.7)	5.51 (140)	5.04 (128)	6.34 (161)	5.04 (128)	4.65 (118)	0.20 (5)	M4	4.62 (2.1)	96.7	52.4	149.1	2
230V Single-Phase	0.13 (0.1)	2.68 (68)	5.04 (128)	2.76 (70)	2.20 (56)	4.65 (118)	0.20 (5)	M4	1.10 (0.5)	3.7	10.4	14.1	1
	0.25 (0.2)	2.68 (68)	5.04 (128)	2.76 (70)	2.20 (56)	4.65 (118)	0.20 (5)	M4	1.10 (0.5)	7.7	12.3	20.0	1
	0.5 (0.4)	2.68 (68)	5.04 (128)	4.41 (112)	2.20 (56)	4.65 (118)	0.20 (5)	M4	1.98 (0.9)	15.8	16.1	31.9	1
	1 (0.75)	4.25 (108)	5.04 (128)	5.08 (129)	3.78 (96)	4.65 (118)	0.20 (5)	M4	3.31 (1.5)	28.4	23.0	51.4	2
	2 (1.5)	4.25 (108)	5.04 (128)	6.06 (154)	3.78 (96)	4.65 (118)	0.20 (5)	M4	3.31 (1.5)	53.7	29.1	82.8	2
460V 3-Phase	0.5 (0.2)	4.25 (108)	5.04 (128)	3.19 (81)	3.78 (96)	4.65 (118)	0.20 (5)	M4	2.20 (1.0)	9.4	13.7	23.1	2
	0.75 (0.4)	4.25 (108)	5.04 (128)	3.90 (99)	3.78 (96)	4.65 (118)	0.20 (5)	M4	2.43 (1.1)	15.1	15.0	30.1	2
	2 (0.75)	4.25 (108)	5.04 (128)	5.08 (129)	3.78 (96)	4.65 (118)	0.20 (5)	M4	3.31 (1.5)	30.3	24.6	54.9	2
	3 (1.5)	4.25 (108)	5.04 (128)	6.06 (154)	3.78 (96)	4.65 (118)	0.20 (5)	M4	3.31 (1.5)	45.8	29.9	75.7	2
	3 (2.2)	4.25 (108)	5.04 (128)	6.60 (154)	3.78 (96)	4.65 (118)	0.20 (5)	M4	3.31 (1.5)	50.5	32.5	83.0	2
	3 (3.0)	5.51 (140)	5.04 (128)	6.34 (161)	5.04 (128)	4.65 (118)	0.20 (5)	M4	4.62 (2.1)	58.2	37.6	95.8	2
	5 (3.7)	5.51 (140)	5.04 (128)	6.34 (161)	5.04 (128)	4.65 (118)	0.20 (5)	M4	4.62 (2.1)	73.4	44.5	117.9	2

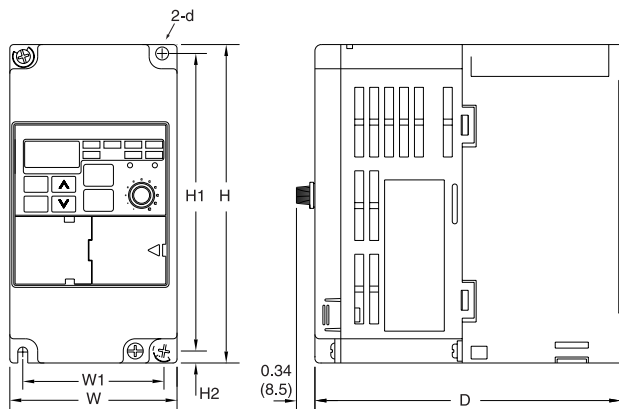

Figure 1

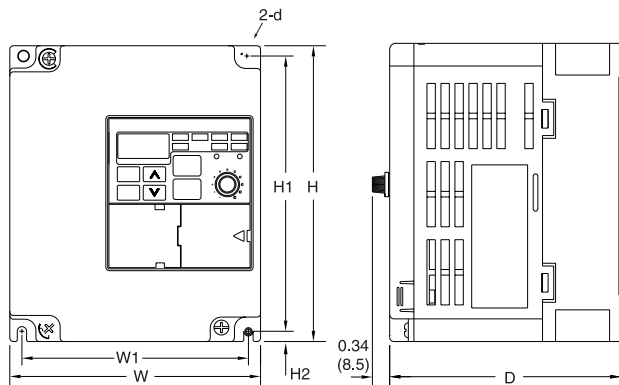

Figure 2

Chapter 2:

Quickstart

What this chapter tells you:

- 1) The features of the digital operator.
- 2) The functions of the digital operator.
- 3) The monitoring U-constants of the VM7.
- 4) Simple data setting of the VM7.



Only qualified personnel should attempt start-up of this equipment. Improper operation could present a hazard to personnel safety or to the driven equipment. This manual must be read and understood in its entirety before any changes are made to the programming parameters. Potentially lethal voltages are present in and around this equipment and extreme caution must be exercised at all times.

2.0 PRE-POWER CHECKS

You must first inspect the installation to make sure the inverter is mounted and wired in accordance with Chapters 1 & 3 of this manual. Take special care to look for the following:

- ☑ Make sure power is off (the red charge LED on the unit must also be off).
- ☑ Check to make sure wiring is secure and all screw terminals are tight.
- ☑ Make sure there is no loose debris in or around the inverter (closely check for metal filings).
- ☑ If possible, make sure the motor is uncoupled from the load. If this isn't possible, make sure the equipment is ready for rotation and be prepared to verify the direction of rotation.
- ☑ Measure the input voltage and make sure it is within the inverter's specifications.
- ☑ Verify the proper direction of motor rotation. This can easily be done by using the Run key on the keypad and apply a FREF to the drive.



You must confirm the model number and output current (HP) rating of the inverter before you apply power. Application of the wrong voltage power supply can cause unit damage.

2.1 OPERATING THE INVERTER

Test Run

The inverter will not operate until the reference frequency (speed) is set. There are three types of run command modes for the (N03):

1. Run command from the digital operator (volume/digital setting).
2. Run command from the control circuit terminal.
3. Run command from communications (MODBUS communications).

Prior to shipping, the drive is set up to receive run command and frequency reference from the operator. Table 2.1 has instructions for running the VM7 using the digital operator. For instructions on operation, refer to pages 2-5 and 2-11.

2.2 OPERATING THE DIGITAL OPERATOR

All functions of the VM7 are set by the digital operator. Below are descriptions of the display and keypad sections.

Digital Operator

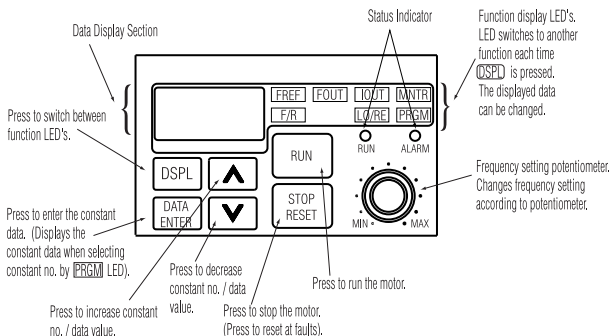

FREF Frequency reference setting/monitoring (GREEN)	FOUT Output frequency monitor (GREEN)	IOUT Output current monitor (GREEN)	MNTR Multi-function monitor (GREEN)
F/R Operator RUN command FWD/REV selection (GREEN)		LO/RE LOCAL/REMOTE Selection (RED)	PRGM Constant no./data (RED)

Table 2.1 VM7 Digital Operator

Operation Steps	Operator Display	12-LED Display	Status Indicator LED
1. Turn the power ON.	0.00		RUN ALARM
2. Turn the speed control fully to the left.	0.00		RUN ALARM
3. F/R blinks. Select FWD/REV run using keys. NOTE: Never select REV when reverse run is prohibited.	FOR or REV		RUN ALARM
4. Press DSPL to blink FREF. Then press RUN.	0.00		RUN ALARM
5. Operates the motor by turning the speed control to the right. (frequency reference corresponds to the speed control position is displayed.) NOTE: If the speed control is switched rapidly, the motor also accelerates or decelerates rapidly corresponding to the speed control movement. Pay attention to load status and switch the volume with the speed not to affect motor movement.	0.00 to 60.00 Minimum output frequency is 1.50Hz		RUN ALARM

Status Indicator Lamp : ON : Blinking : OFF

Operation Check Points

- Motor rotates smoothly
- Motor rotates in the correct direction
- Motor does not have abnormal vibration or noise
- Acceleration or deceleration is smooth
- Current matching the load flows
- Status indicator LED's and digital operator display are correct

Chapter 2: Quickstart

Description of Status Indicator LED's

There are two LED's on the middle right section of the face of the VM7. The inverter status is indicated by various combinations of ON, BLINKING, and OFF LED's.

☼ ON ⚡ BLINKING (long blinking) ⚡ BLINKING ● OFF



For details on how the status indicator LED's function at inverter faults, refer to Chapter 5 "PM and TROUBLESHOOTING" on page 5-5. If a fault occurs, the ALARM LED lights.

NOTE:

The fault can be reset by turning ON the fault reset signal (or pressing key on the digital operator) with the operation signal OFF or by turning OFF the power supply. If the run signal is ON, the fault cannot be reset by the fault reset signal.

2.3 LED DESCRIPTION

By pressing (DSPL) on the digital operator, each of the function LED's can be selected.

The following flowchart describes each function LED.

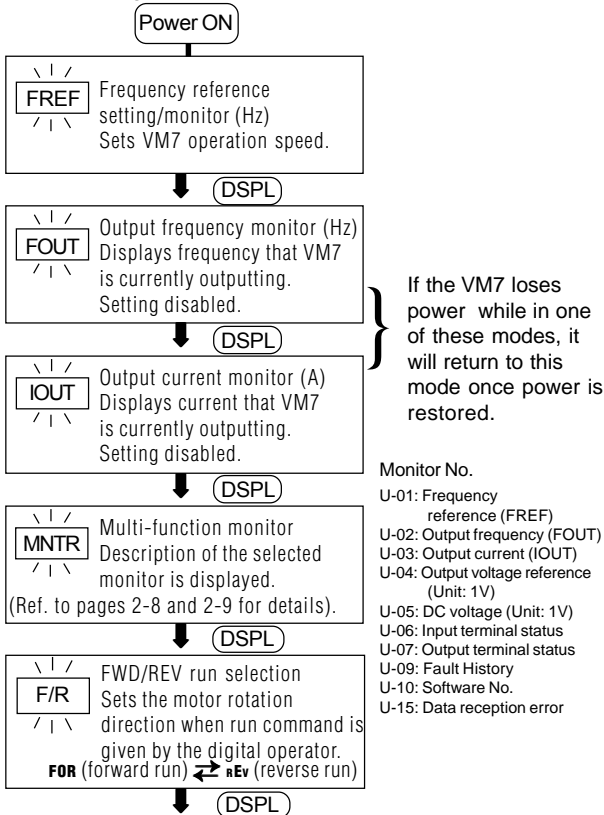

Chapter 2: Quickstart



 LOCAL/REMOTE Selection
 This function switches the operation: operation using the digital operator including frequency setting with volume, or that using the input terminals or through communications.

L₀ (Local) ↔ R₀ (Remote)



DSPL

 Constant No./Data
 Sets and changes data using constant No. (Refer to page 4-10).



DSPL

Return to **FREF**

MNTR Multi-Function Monitor

Selecting monitor

Press **DSPL** key. When **MNTR** is ON, data can be displayed by selecting monitor constant no.

Example: Monitoring Output Voltage Reference

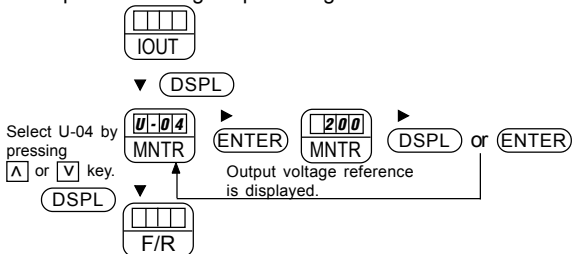

2.4 MONITORING

Following items can be monitored by U-constants.

Constant Number	Name		Description
U-01	Frequency reference (FREF) *1	Hz	Frequency reference can be monitored. (Same as FREF)
U-02	Output frequency (FOUT) *1	Hz	Output frequency can be monitored. (Same as FOUT)
U-03	Output current (IOUT)*1	Hz	Output current can be monitored. (Same as IOUT).
U-04	Output voltage	V	Output voltage can be monitored.
U-05	DC voltage	V	Main circuit DC voltage can be monitored.
U-06	Input terminal status *2	-	Input terminal status of control circuit terminals can be monitored.
U-07	Output terminal status *2	-	Output terminal status of control circuit terminals can be monitored.
U-09	Fault history (last 4 faults)	-	Last four fault history is displayed.
U-10	Software No.	-	Software No. can be checked.
U-15	Data reception error *4	-	Contents of MODBUS communication data reception error can be checked. (contents of transmission register No. 003DH are the same)

*1 The status indicator LED is not turned ON.

*2 Refer to the next page for input/output terminal status.

Fault history display method

When U-09 is selected, a four-digit box is displayed. The three digits from the right show the fault description, and the digit on the left shows the order of fault (from one to four). Number 1 represents the latest fault, and 2, 3, 4, in ascending order of fault occurrence.

Chapter 2: Quickstart

Example:

- □ □ □ 4-digit numbers
- : Order of fault (1 to 4)
- □ □ : Fault description
- “---” is displayed if there is no fault.
- (Refer to page 5-6 for details.)

- Clearing fault history

Set constant n01 to 6 to clear fault history. Display returns to n01 after completion of 6 setting.

NOTE: Constant initialize (n01 = 10, 11) clears fault history.

2.5 SETTING AND REFERRING CONSTANTS

Following shows how to select and change constants.

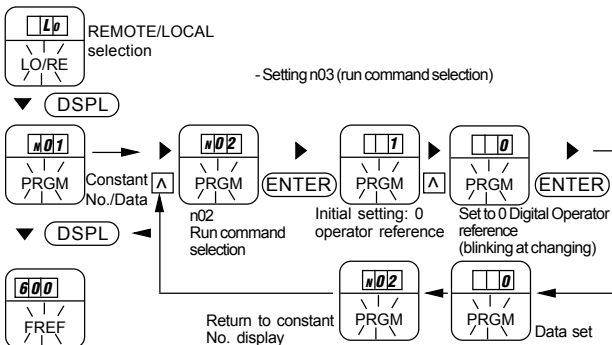

2.6 SIMPLE DATA SETTING

Speed control setting [refer to page 2-5 (Step 5) OPERATING THE INVERTER] and digital setting are both available for simple accel/decel operation of the VM7. Frequency setting analog voltage is set with factory setting (n03 = 2)

Following is an example in which the digital operator keys are used to set frequency reference, acceleration time, deceleration time, motor direction and start/stop.

Operation Steps	Operator Display	LED Display	Status Indicator LED
1. Turn ON the power supply.	0.0		RUN ALARM
2. Set constant n07 to 1.	1		RUN ALARM
3. Set the following constants n016 : 15.0 (acceleration time) n017 : 5.0 (deceleration time)	15.0 5.0		RUN ALARM
4. Select forward or reverse run by pressing ▲ or ▼ key. NOTE: Examine the application. (Never select REV when reverse run is prohibited.)	For (Forward) or rEv (Reverse)		RUN ALARM
5. Set Lo (local mode) by pressing ▲ or ▼ key.	Lo		RUN ALARM
6. Set the reference by pressing ▲ or ▼ key.	60.0		RUN ALARM
7. Press (RUN)	60.0 to 0.0		RUN ALARM
8. Press (STOP) to stop.	60.0 to 0.0		RUN Alarm

Status Indicator Lamp : Blinking (Long Blinking) : Blinking : OFF

This page intentionally left blank.

Chapter 3:

Wiring

What this chapter tells you:

- 1) General wiring precautions.
- 2) How to wire the power circuit.
- 3) How to wire the control circuit.
- 4) Proper grounding practice.

Chapter 3: Wiring

Only trained, qualified personnel should be used to install the VM7. Hazardous voltage levels are present that could jeopardize the safety of personnel. Do not attempt any wiring with power in the drive cabinet. Never change any inverter wiring until power is removed and the charge LED on the control board is extinguished.

3.0 GENERAL PRECAUTIONS



Do not attempt to change any wiring while there is voltage present in the cabinet. Never trust the visual position of a disconnect switch or input contactor alone without using a meter or suitable test device to *guarantee* that all power sources have been disconnected. In particular, look for yellow wiring to indicate external control power supply.

Connect the main AC power to the input power terminals L1 (R), L2 (S) & L3 (T). Do not connect the input power supply to the VM7 output terminals T1 (U), T2 (V) & T3 (W). Failure to follow this warning could lead to unit damage.



The local codes and the NEC guidelines should be followed when connecting the wiring.

Please try to run the motor wiring in separate conduit or wire tray from the inverter's input power wiring.

Branch circuit protection must be provided externally to comply with the NEC.

Make sure all screws are tightened before any power is applied to the unit.

Check for loose debris or wire clippings before power is applied.

Make sure no wires strands are touching adjacent strands.

Physically separate the inverter's control wiring from power wiring. If they must cross, do so at right angles (90°).

Size the incoming power feeder per NEC in keeping the voltage drop to within 2%, depending upon the wiring distance

3.1 POWER WIRING



NOTE: You must provide branch circuit protection to comply with the requirements of the NEC and any other applicable local codes. Do not attempt any wiring unless all power is removed from the drive cabinet and the charge LED on the control board is extinguished.

3.1.1 Power Wiring Precautions

Be sure to provide either branch circuit protection (either CB or input fuses) between the incoming power source and the VM7 inverter.

Make sure that any ground fault interrupter is rated for a minimum of 200 mA earth leakage current to prevent nuisance trips.

If the source is greater than 600 KVA you should connect a 3% impedance input line reactor to minimize the peak capacitor charging currents.

If you choose to connect a contactor between the inverter output and the motor, you must make sure the contactor is never switched while the inverter is operating. Otherwise, the peak currents or voltage could cause nuisance trips.

Never connect the incoming AC input power to the output terminals (T1 (U), T2 (V), or T3 (W)).

Separate the incoming power leads from the inverter output wiring whenever possible.

Separate control leads (120 V or less) from power leads. If they must cross, make sure they do so at 90° angles.

Use R-C surge suppressors across the coils of any contactors installed in a control panel with the inverter.

You must install separate motor thermal protection (overload relay or thermostat) whenever more than one motor is connected to the inverter output.

Make sure the resistance to earth is less than 100 Ω (230 V units) or 10 Ω (460 V units). Never ground the inverter in common with welding machines, large motors, arc furnaces, or other high current devices.

Never connect power factor correction capacitors directly to the input or output of the VM7.

3.1.2 Input Protection



The following are only recommended values. You must always conform to the NEC and local applicable codes.

You must install branch circuit protection between the inverter input and the incoming AC power supply. Our recommendations are given in Table 3.1.

Table 3.1 Recommended Input Protection

Model Number VM7- 3-Phase	Input Ratings (A)	Time Delay Fuse / MCCB
20P1	1.1 / (1.8)	5A / (5A)
20P2	1.8 / (3.5)	5A / (5A)
20P4	3.9 / (7.4)	5A / (10A)
20P7	6.4 / (12.8)	10A / (20A)
21P5	11 / (20.5)	20A / (20A)
22P2	15.1 / (28.2)	20A / (40A)
23P7	24 / (44.8)	30A / (50A)
40P2	1.6	5A
40P4	2.4	5A
40P7	4.2	5A
41P5	7.0	10A
42P2	8.1	10A
43P7	13.5	20A

3.1.3 Wire Selection Recommendations

Table 3.2 below gives recommended *minimum* wire sizes for the VM7 inverter. You must size the wiring in accordance with NEC and with locally accepted practices.

Table 3.2 Recommended Wire Sizes

Model Number VM7- 3-Phase	Power (AWG / MM ²)		Control (AWG / MM ²)
20P1	14 / 2.1	14 / 2	18 / 0.82
20P2	14 / 2.1	14 / 2	
20P4	14 / 2.1	14 / 2	
20P7	14 / 2.1	12 / 3.3	
21P5	14 / 2.1	10 / 5.3	
22P2	12 / 3.3	10 / 5.3	
23P7	12 / 3.3	8 / 8.4	
40P2	14 / 2.1		
40P4	14 / 2.1		
40P7	14 / 2.1		
41P5	14 / 2.1		
42P2	14 / 2.1		
43P7	14 / 2.1		

Chapter 3: Wiring

3.1.4 Power Interconnect Wiring

Please refer to Figure 3.1 below for the proper power interconnections.

Figure 3.1 Power Interconnect Wiring

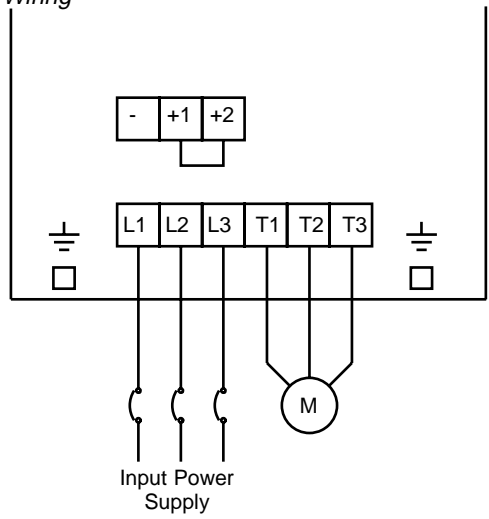

3.2 CONTROL WIRING



Warning: Make sure the input control wiring is consistent with the programmed start/stop method. Wiring 2-wire control inputs into a drive programmed for 3-wire control could result in unexpected operation.

3.2.1 Control Wiring Precautions

Physically separate control wiring from power wiring. If they must cross, make sure they do so at 90° angles.

Use twisted, shielded wires for the analog input or output signals (use Belden no. 8760 for 2 wire and use Belden no. 8770 for 3 wire, or their equivalents).

Control wiring must be less than 164 ft. (50 m) in length. Please note: the maximum allowable cable length is installation dependent due to electrical noise considerations.

Observe proper grounding methods by connecting only one end of the shield sheath to ground. Typically, you should connect the shield on the inverter's side.

Separate any 120 VAC control wiring from the DC wiring. Never connect AC power to any input terminals without using a suitable interface card.

Use R-C type surge absorbers across any contactors in the VFD panel. MOV type absorbers alone are not adequate in reducing electromagnetically coupled noise.

3.2.2 Terminal Locations

The control terminals can be found at the bottom of the control card (as shown on the next page). These terminals are suitable for 20-16 AWG wire (0.5-1.25 mm²).

Chapter 3: Wiring

3.2.3 Control Circuit Terminals

Pass the cable through wiring hole and connect. Be sure to mount the cover in its original position.

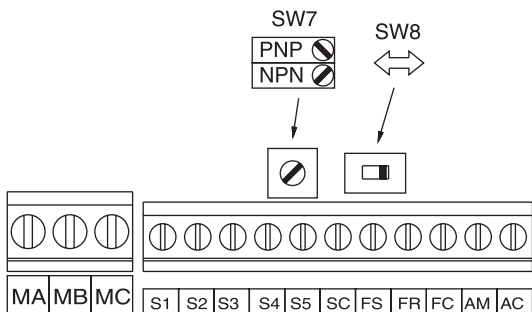

*SW7 can be changed according to input signal polarity.
 0V common: NPN side (factory setting)
 24 common: PNP side
 Refer to page 4-21 for SW2

Wiring the control circuit terminals

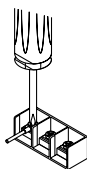

Screwdriver blade width

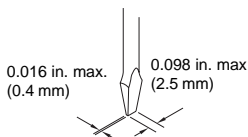

Insert the wire into the lower part of the terminal block and connect it tightly with a screwdriver.

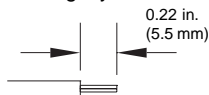

Wire sheath strip length must be 0.22 in (5.5 mm).

3.2.4 Terminal Definitions

The VM7 incorporates multi-function type inputs and outputs in the control circuit. Refer to table 3.4 for the control circuits and function.

Table 3.4 Control Terminal Definitions

Type	Terminal	Name	Function (Signal Level)		
Control Circuit	Input	Sequence	S1 Multi-function input selection 1	Photo-coupler insulation 24 VDC, 8 mA	
			S2 Multi-function input selection 2		Factory setting closed: FWD run, open: REV run
			S3 Multi-function input selection 3		Factory setting closed: REV run, open: FWD run
			S4 Multi-function input selection 4		Factory setting: External fault (NO contact)
			S5 Multi-function input selection 5		Factory setting: Fault reset
			SC Multi-function input selection common		Factory setting: Multi-step speed reference 1 For control signal
	Frequency reference	FS Power for frequency setting	+12V (permissible current 20 mA max.)		
		FR Master speed frequency reference	0 to +10 VDC (20k ohm) or 4 to 20 mA (250k ohm) (1/1000 resolution)		
		FC Frequency reference common	0V		
	Output	Multi-function contact output	MA NO contact output	Factory setting: fault	Contact capacity 250 VAC 1A or less, 30 VDC 1A or less
			MB NC contact output		
			MC Contact output common		
		AM Analog monitor output	Factory setting: Output frequency 0 to +10 V	+10 VDC, 2 mA or less, 8-bit resolution	
		AC Analog monitor common	0V		

Chapter 3: Wiring

3.2.5 Standard I/O Wiring

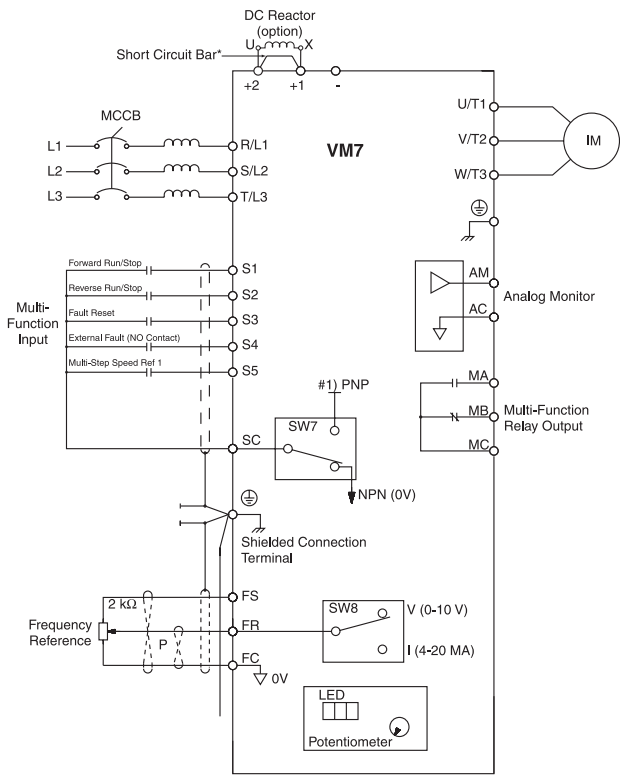

* Short circuit bar should be removed when connecting DC reactor.

3.3 GROUNDING



Warning: A solid ground is required for personnel safety and to guarantee reliable, nuisance free operation.

You must provide a low impedance ground connection to the VM7 on the green Earth Ground terminal on the heatsink assembly.

The resistance to ground must be less than 100 Ω (230 V units) or 10 Ω (460 V units). You should always keep the ground connections as short as possible.

Never ground the VM7 in common with large current equipment such as welding machines, arc furnaces, or large motors.

If you have an installation with multiple inverter units, be sure to follow the wiring practice given below in Figure 3.7.

Figure 3.7 Proper Grounding Methods

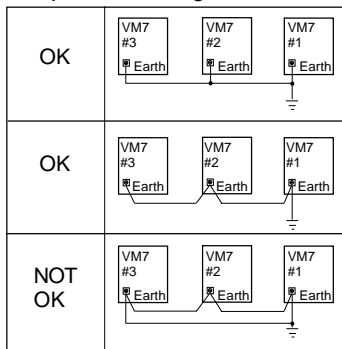

This page intentionally left blank.

Chapter 4:

Programming

Note: Refer to Appendix A for a complete listing of parameters.

What this chapter tells you:

- 1) Introduction to the VM7 keypad.
- 2) How to program the VM7.
- 3) Simple programming examples.
- 4) Programming Parameters
 - First Functions (n01 to n35)
 - Second Functions (n36 to n79)



Note: This chapter must be read in its entirety before any programming changes are attempted. Only authorized personnel should modify the inverter settings as power is applied and lethal voltages may be present.

4.0 PROGRAMMING

This chapter details the programming of the VM7 inverter unit. The programming parameters are organized in a numeric fashion with an appropriate FUNCTION code ("N" prefix). These parameters shouldn't be changed unnecessarily.

The first part of the chapter deals with the programming method. Step-by-step programming examples are then provided for some of the more commonly changed parameters. Finally, a complete parameter list is provided in Appendix A.

4.1 KEYPAD LAYOUT

The VM7 keypad has 6 buttons and 7 LEDs as shown on the facing page. Please refer to page 4-4 for a detailed description of the LEDs.

4.2 KEY FUNCTIONS

You will only need to use the display (DSPL) and enter keys and the arrow keys to setup the inverter.

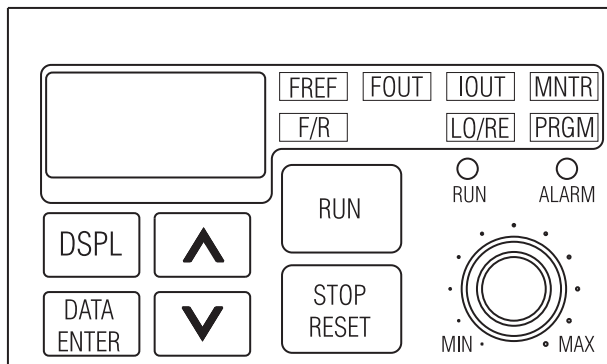

4.2.1 Display Key DSPL

The Display (DSPL) key is context sensitive and has multiple functions. It is used to navigate between the various drive (operating) modes and the programming (setup) mode. It is also used to switch the display function between the FUNCTION LED's and between the edit screen for each PROGRAM.

4.2.2 Up/Down Arrows ^ v

These keys are used to edit the selected data. These keys will allow fine-tuning or a quick scroll, depending upon the length of time the key is depressed.

4.2.3 Basic LED Description

By pressing (DSPL) on the digital operator, each of the function LED's can be selected.

The following flowchart describes each function LED.

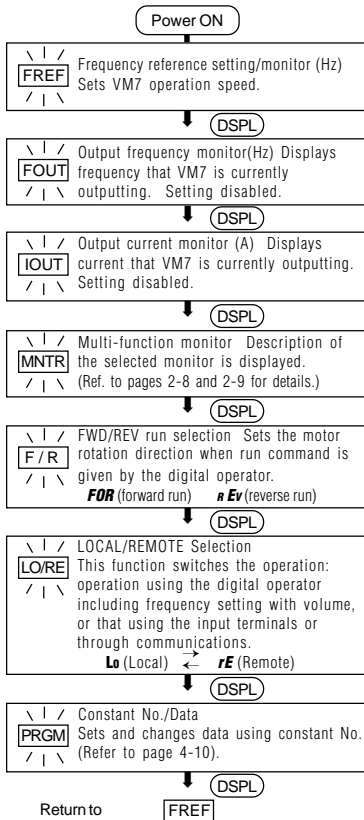

If the VM7 loses power while in one of these modes, it will return to this mode once power is restored.

Monitor No.

- U-01: Frequency reference (FREF)
- U-02: Output frequency (FOUT)
- U-03: Output current (IOUT)
- U-04: Output voltage reference (Unit: 1V)
- U-05: DC voltage (Unit: 1V)
- U-06: Input terminal status
- U-07: Output terminal status
- U-09: Fault History
- U-10: Software No.
- U-15: Data reception error

4.2.4 Switching LOCAL/REMOTE Modes

The following functions can be selected by switching the LOCAL or REMOTE mode. To select RUN/STOP commands or frequency reference, change the mode in advance depending on the following applications.

- LOCAL mode: Enables the digital operator for RUN/STOP commands and FWD/REV run commands. Frequency reference can be set by volume or **FREF**
- REMOTE mode: RUN/STOP commands and FWD/REV run commands can be given by the digital operator, control circuit terminal or transmission.
 - n02 = 0: Enables digital operator. (LOCAL)
 - = 1: Enables control circuit terminal. (REMOTE)
 - = 2: Enables transmission (when option card is installed).

Setting of frequency reference selection (n03) becomes valid.

- How to select LOCAL/REMOTE modes

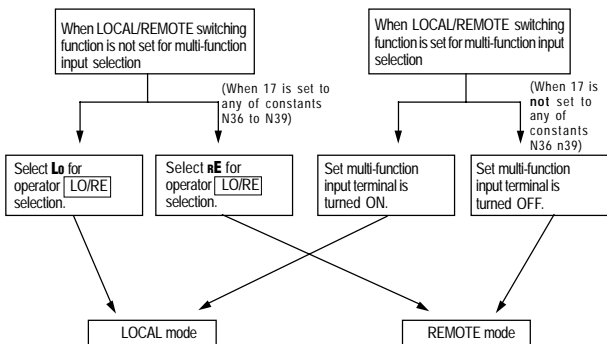

4.2.5 Selecting Run/Stop Commands

Refer to switching LOCAL/REMOTE modes (page 4-5) to select either the LOCAL mode or REMOTE mode.

Operation method (RUN/STOP commands, FWD/REV run commands) can be selected by the following method.

- LOCAL mode

When LO (local mode) is selected for digital operator **LO/RE** selection, run operations (run/stop) is enabled by the **STOP** or **RUN** of the digital operator, and forward/reverse run is enabled by blinking F/R lamp (using **V** or **Λ** key).

- REMOTE mode

- Select remote mode.

Following are two methods to select remote modes.

1. Select rE (remote mode) for **LO/RE** selection.
 2. When the local/remote switching function is selected for multi-function input selection, turn OFF the input terminal to select remote mode.
- Select operation method by setting the constant n02.

- n02 = 0 :Enables the digital operator (same with local mode).
- = 1 :Enables the multi-function input terminals (figure on following page).
- = 2 :Enables serial communications.

Example for using the multi-function input terminal as operation reference (two-wire sequence).
For an example of three-wire sequence, refer to page 4-22.

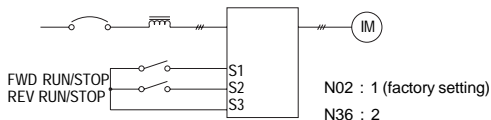

- Operating (RUN/STOP commands) by communications Setting constant n02 to 2 in REMOTE mode can give RUN/STOP commands by communication (MODBUS communications).

4.2.6 Selecting Frequency Reference

Frequency reference can be selected by the following methods.

- Setting by operator
Select REMOTE or LOCAL mode in advance. For the method of selecting the mode, refer to page 4-5.

LOCAL Mode

Parameter n07 determines where the frequency reference is input from when in the local mode.

n07 = 0: Enables the setting by volume on digital operator (initial setting)

Factory setting of the model with operator (without volume) is n07 = 1.

- = 1: Enables the digital setting by digital operator, setting value is stored in parameter n21 (frequency reference 1).

Chapter 4: Programming

- Digital setting by digital operator

Input frequency while FREF is illuminated (press ENTER after setting the desired frequency value).

Frequency reference setting is immediately effective when n08 = 1, the ENTER key does not have to be pressed to enter the reference.

n08 = 0: Enables frequency acceptance by ENTER key.

= 1: Disable frequency reference setting by ENTER key. It is not necessary to press the ENTER key to accept the reference.

- REMOTE Mode

Parameter n03 determines where the frequency reference accepted from when in the REMOTE mode.

n03 = 0: Enables frequency reference setting by volume on digital operator.

= 1: Frequency reference 1 (parameter n21) is effective

= 2: Voltage reference terminal "FR" is effective (0 to 10V) (see figure on pg. 4-19)

= 3: Current reference terminal "FR" is effective (4 to 20 mA) (refer to page 4-18)*

= 4: Current reference terminal "FR" is effective (0 to 20 mA) (refer to page 4-18)*

= 6: Communication (refer to page 4-18)

*NOTE: SW8 must be set to the "1" position when using terminal "FR" as a current reference input.

Example of frequency reference by voltage signal

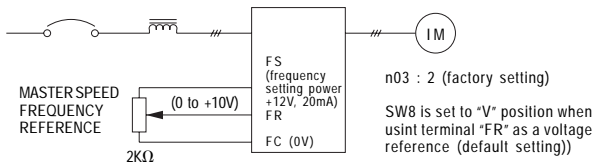

- Setting by transmission

LOCAL/REMOTE switching function is selected for multi-function input selection, turn OFF the terminal input to set the remote mode.

4.3 FIRST FUNCTIONS (n01 - n39)

Factory settings of the constants are shown as in the tables.

4.3.1 Constant Set-up and Initialization (n01)

The following table describes the data which can be set or read when n01 is set.

Unused constants among n01 to n79 are not displayed.

n01 Setting	Constant that can be set	Constant that can be viewed
0	n01	n01 to n79
1	n01 to n79*	n01 to n79
6	Fault history cleared	
7	Not used	
10	Initialize (2-wire sequence)	
11	Initialize (3 wire sequence)	

*Excluding setting disabled constants.

NOTE: “**ERR**” appears on the LED display for one second and the set data returns to its initial values in the following cases:

- (1) The set values of input terminal function selection 2 to 5 (n36 to n39) are the same.
- (2) If the following conditions are not satisfied in the voltz/Hz pattern setting (V/f pattern setting):
 - Max.output frequency (n09) \cong Max. voltage output frequency (n11)
 - > Mid. output frequency (n12)
 - \cong Min. output frequency (n14)
- For details, refer to “Adjusting torque according to application” (V/f pattern setting) on page 4-13.
- (3) If the following conditions are not satisfied in the Jump frequency setting:
 - Jump frequency 2 (n50) \cong Jump frequency 1 (n49)
- (4) If frequency reference lower limit (n31) \cong Frequency reference upper limit (n30)
- (5) If Electronic thermal reference current (n32) \cong 150% of inverter rated current

4.3.2 When torque is not sufficient at a low speed

If sufficient torque cannot be obtained, change the V/f pattern settings of n09 to n15 to those for high-start V/f.

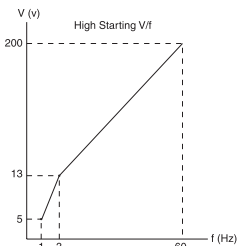
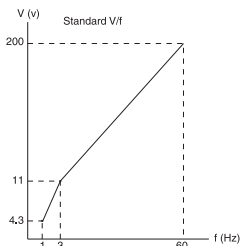

4.3.3 Using V/f Mode

Adjusting torque according to application

Adjust motor torque by using “V/f pattern” and “full-range automatic torque boost”.

- V/f pattern setting

Set V/f pattern by n09 to n15 as described below. Set each pattern when using a special motor (high-speed motor, etc.) or when requiring special torque adjustment of machine.

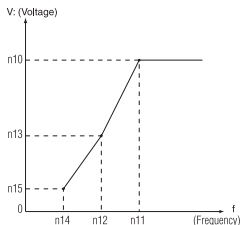

Be sure to satisfy the following conditions for the setting of n09 to n15 .
 $n14 \leq n12 < n11 \leq n09$
 If $n14 = n12$ is set, the set value of n13 is disabled.

Constants Number	Name	Unit	Setting Range	Initial Setting
n09	Max. output frequency	0.1Hz	50 to 400Hz	60Hz
n10	Max. voltage	1V	1 to 255V (0.1 to 510V)	230V (460V)
n11	Max. voltage output frequency (base frequency)	0.1Hz	0.2 to 400Hz	60Hz
n12	Mid. output frequency	0.1Hz	0.1 to 399.9Hz	1.5Hz
n13	Mid. output frequency voltage	1V	0.1 to 255V (0.1 to 510V)	12V (24V)
n14	Min. output frequency	0.1Hz	0.1 to 10Hz	1.5Hz
n15	Min. output frequency voltage	1V	1 to 50V (0.1 to 100V)	12V (24V)

• Typical setting of V/f pattern

Set the V/f pattern according to the application as described below. For 400V class, the voltage values (n10, n13 and n15) should be doubled. When running at a frequency exceeding 50Hz/60Hz, change the maximum output frequency (n09).

NOTE: Be sure to set the maximum output frequency according to the motor characteristics.

(1) For general-purpose applications

Motor Specifications: 60Hz
(Factory Setting)

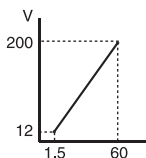

Constant	Setting
n09	60
n10	200
n11	60
n12	1.5
n13	12
n14	1.5
n15	12

Motor Specifications: 50Hz

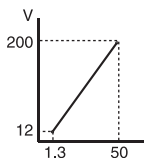

Constant	Setting
n09	50
n10	200
n11	50
n12	1.3
n13	12
n14	1.3
n15	12

(2) For fans/pumps

Motor Specifications: 60Hz

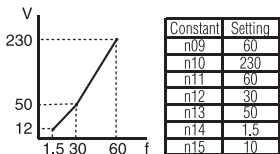

Motor Specifications: 50Hz

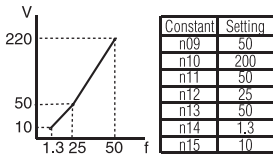

(3) For applications requiring high starting torque

Motor Specifications: 60Hz

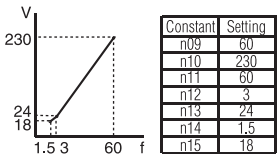

Motor Specifications: 50Hz

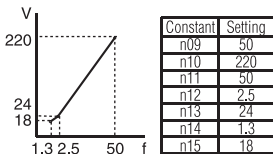

Increasing voltage of V/f pattern increases motor torque, but an excessive increase may cause motor overexcitation, motor overheat or vibration.

NOTE: n10 is to set to motor rated voltage.

When operating with frequency larger than 60 Hz / 50 Hz, change only max. output frequency (n09).

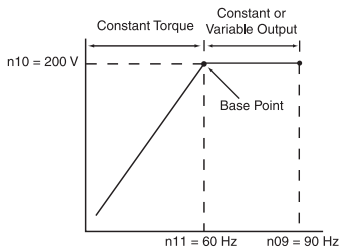

Full-range automatic torque boost motor torque requirement changes according to load conditions. Full-range automatic torque boost adjusts voltage of V/f pattern according to the requirement. The VM7 automatically adjusts the voltage during constant-speed operation as well as during acceleration.

The required torque is calculated by the inverter.

This ensures tripless operation and energy-saving effects.

$$\boxed{\text{Output voltage}} \propto \boxed{\text{Automatic torque boost gain (n63)}} \times \boxed{\text{Required torque}}$$

- Operation

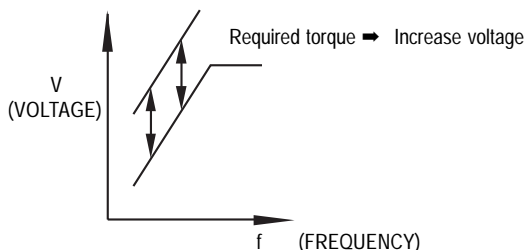

Normally, no adjustment is necessary for automatic torque boost gain (n63 factory setting : 1). When the wiring distance between the inverter and the motor is long, or when the motor generates vibration, change the automatic torque boost gain. In these cases, set the V/f pattern (n09 to n15).

Note : \propto means proportional to

4.3.4 Decreasing Motor Speed Fluctuation

Slip Compensation

As the load becomes larger, motor speed is reduced and motor slip value is increased. The slip compensating function controls the motor speed at a constant value even if the load varies.

When inverter output current is equal to the motor rated current (electronic thermal reference current, n32), the compensation frequency is added to the output frequency.

Compensation frequency = Motor rated slip (n64)

$$\times \frac{\text{Output current} - \text{Motor no-load current}}{\text{Electronic thermal reference current} (n32) - \text{Motor no-load current} (n65)}$$

$$\times \text{Slip compensation gain} (n66)$$

Constants

Constant Number	Name	Unit	Setting Range	Initial
n32	Motor rated current	0.1A	0 to 120% of inverter rated current	*
n64	Motor rated slip	0.1Hz	0.0 to 20Hz	*
n65	Motor no-load current	1%	0 to 99% (100% = Motor rated current n32)	*
n66	Slip compensation gain	0.1	0.0 to 2.5	0.0
n67	Slip compensation time constant	0.1s	0.0 to 25.5s When 0.0s is set, delay time becomes 2.0s	2.0s

*Differs depending on inverter capacity.

NOTES:

- Slip compensation is not performed in the following condition:
Output frequency < minimum output frequency (n14)
- Slip compensation is not performed during regeneration.
- Slip compensation is not performed when motor rated current (n32) is set to 0.0 A.

4.3.5 Selecting Run/Stop Commands (n02)

Refer to switching LOCAL/REMOTE modes (page 4-5) to select either the LOCAL mode or REMOTE mode.

Operation method (RUN/STOP commands, FWD/REV run commands) can be selected by the following method.

- LOCAL mode

When LO (local mode) is selected for digital operator **LO/RE** selection, run operations (run/stop) is enabled by the **STOP** or **RUN** of the digital operator, and forward/reverse run is enabled by blinking F/R lamp (using **V** or **Λ** key).

LO/RE is not effective when local/remote switching function is selected for multi-function input selection.

- REMOTE mode

- Select remote mode.

Following are two methods to select remote modes.

1. Select rE (remote mode) for **LO/RE** selection.
2. When the local/remote switching function is selected for multi-function input selection, turn OFF the input terminal to select remote mode.

- Select operation method by setting the constant n003.

- n02 = 0: Enables the digital operator (same with local mode)
- = 1: Enables the multi-function input terminal (see fig. below)
- = 2: Enables communications (refer to page 4-55)

Example for using the multi-function input terminal as operation reference (two-wire sequence).

For example of three-wire sequence, refer to page 4-23.

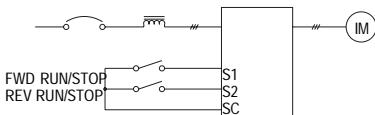

n02 : 1 (Factory Setting)
N36 : 2

Chapter 4: Programming

- Operating (RUN/STOP commands) by communications Setting constant n02 to 2 in REMOTE mode can give RUN/STOP commands by communication (MODBUS communications).

4.3.6 Selecting Frequency Reference (n03)

Frequency reference can be selected by the following methods.

- Setting by operator
Select REMOTE or LOCAL mode in advance. For the method for selecting the mode.
- LOCAL mode
Select command method by constant n07.
n07 = 0 : Enables the setting by potentiometer on digital operator.
= 1 : Enables the digital setting by digital operator, setting value is stored in constant n21 (frequency ref. 1).
- Digital setting by digital operator
Input frequency while FREF is lit (press ENTER after setting the numeric value).
* Frequency reference setting is effective when 1 (initial setting) is set to constant n08 instead of pressing ENTER key.
n08 = 0 : Enables frequency reference setting by ENTER key.
= 1 : Disables frequency reference setting by ENTER key.

- REMOTE mode

Select command method by constant n03.

- n03 = 0: Enables frequency reference setting by potentiometer on digital operator.
- = 1: Effective frequency reference 1 (constant n21)
- = 2: Voltage reference (0 to 10V) (See the figure below)
- = 3: Current reference (4 to 20mA)
- = 4: Current reference (0 to 20mA)
- = 6: Communication (Refer to page 4-51)

Example of frequency reference by voltage signal

- Setting by transmission

LOCAL/REMOTE switching function is selected for multi-function input selection, turn OFF the terminal input to set the remote mode.

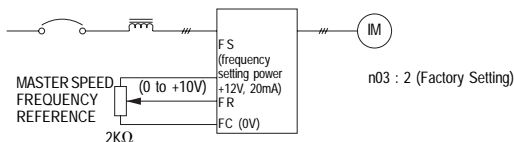

4.3.7 Selecting Frequency by Current Reference Input

When setting frequency by inputting current reference (4-20mA) from control circuit terminal FR, switch the dip switch SW8 on the control circuit board to "I" side.

SW8 is accessed by removing the digital operator.

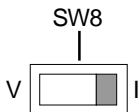
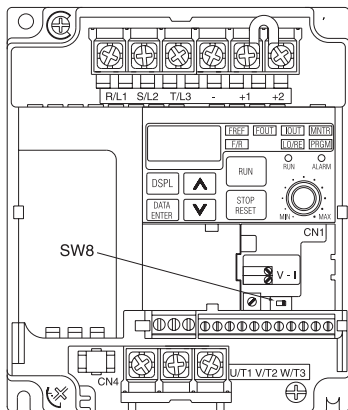

NOTE:

Never input voltage reference to control circuit terminal FR when DIP switch SW8 is switched to "I" side.

Current reference selection

Select current reference as shown below.

4-20mA....n04 = 3

0-20mA....n04 = 4

After changing DIP switch (SW8), select **PRGM** on the digital operator, then set the following constants.

4 - 20 mA ... n03 = 3
0 - 20 mA ... n03 = 4

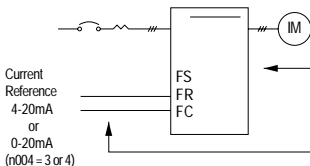

Press the digital operator keys to run or stop the inverter. Switch run and stop direction by setting F/R LED.

Set frequency by the analog current signal [10-100% (max. frequency)/4-20mA or 0-20 mA] connected to the control circuit terminal.

- Setting : n02 = 1, n03 = 3 or 4

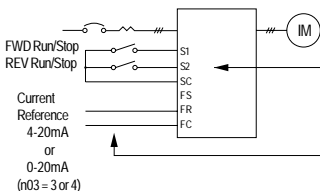

Switch run/stop and FWD/REV run with switching device connected to the control circuit terminal.

Multi-function input terminals S2 is set to reverse run / Stop (n036 = 2).

Set frequency by the analog current signal [0-100% (max. frequency)/4-20mA or 0 to 20 mA] connected to the control circuit terminal.

Frequency reference gain (n41)/bias (n42) can be set even when current reference input is selected. For details, refer to "Adjusting speed setting signal" on page 4-7.

Terminal function at 3-wire sequence selection

When 0 is set at the terminal S3 (n37), terminal S1 becomes run command, terminal S2 becomes stop command, and terminal S3 becomes FWD/REV run command.

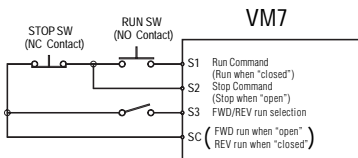

- LOCAL/REMOTE select (setting: 17)

Selects operation reference by the digital operator or by the multi-function input terminal. LOCAL/REMOTE select is available only during stop.

Open : Run according to the setting of run command selection (n02) or frequency reference selection (n03).

Closed: Run by frequency reference and run command from digital operator

Frequency reference changes according to the setting of n008 (local mode)

Example: Set n02 = 1, n03 = 2, n07 = 0

Open : Run by frequency reference from multi-function input terminal FR and run command from multi-function input terminals S1 to S7.

Closed: Run by volume frequency reference and run command from the digital operator.

- UP/Down command (setting: n039 = 34)

With the FWD (REV) run command entered, accel/decel is enabled by inputting the UP or DOWN signals to multi-function input terminals S4 and S5 without changing the frequency reference, so that operation can be performed at the desired speed. When Up/Down commands are specified by n39, any function set to n38 becomes disabled; terminal S4 becomes an input terminal for the UP command and terminal S5 for the DOWN command

Multi-Function Input Terminal S4 (Up Command)	Closed	Open	Open	Closed
Multi-Function Input Terminal S5 (DOWN Command)	Open	Closed	Open	Closed
Operation Status	Accel	Decel	Hold	Hold

4.3.8 Selecting Stopping Method (n04)

Selects the stopping method suitable for application.

Setting	Description
0	Deceleration to Stop
1	Coast to stop

- **Deceleration to stop**

Example when accel/decel time 1 is selected

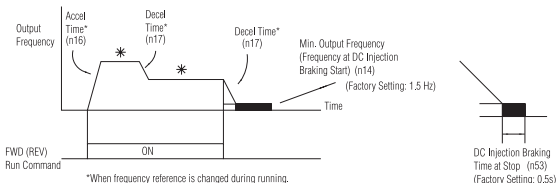

Upon removal of the FWD (REV) run command, the motor decelerates at the decel rate determined by the time set to decel time 1 (n17) and DC injection braking is applied immediately before stop. If the decel time is short or the load inertia is large, overvoltage (OV) fault may occur at deceleration. In this case, increase the decel time or install an optional braking resistor.

Braking torque: Without braking resistor: Approx. 20% torque of motor rating
 With braking resistor: Approx. 150% torque of motor rating

Chapter 4: Programming

4.3.9 Setting Reverse Run Prohibit (n05)

“Reverse run disabled” setting does not accept a reverse run command from the control circuit terminal or digital operator. This setting is used for applications where a reverse run command can cause problems.

Setting	Description
0	Reverse run enabled
1	Reverse run disabled

4.3.10 Operator Stop Key Selection (n06)

Selects processing when STOP key is pressed during operation from multi-function input terminal.

Setting	Description
0	STOP key effective when running from multi-function input terminals. When STOP key is pressed, the inverter stops according to the setting of constant n04. At this time, the digital operator displays "STP" alarm (blinking). This stop command is held in the inverter until both forward and reverse run commands are open.
1	STOP key ineffective when running from multi-function input terminals.

Detection of Keypad

n07 Selection Frequency
Ref. in local mode (refer to page 4-7)

n08 Frequency Referency Setting
Method from digital operator (refer to page 4-8)

Volts per Hertz Setting

n09-n15 (refer to page 4-12)

4.3.11 Using Two Accel/Decel Times

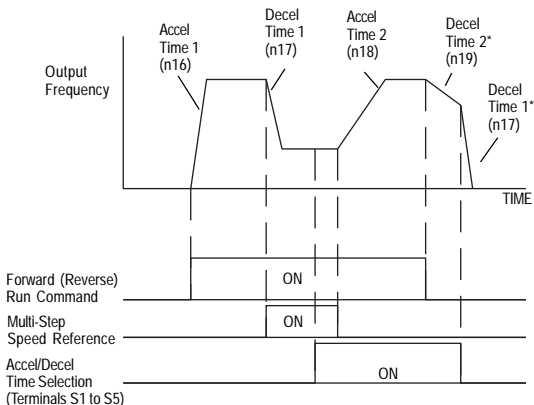

*When "deceleration to a stop" is selected (n04 = 0).

By setting input terminal function selection (either of n36 to n39) to "11 (accel/decel time select)", accel/decel time is selected by turning ON/OFF the accel/decel time select (terminal S1 to S5).

At OFF : n16 (accel time 1)
n17 (decel time 1)

At ON : n18 (accel time 2)
n19 (decel time 2)

No.	Name	Unit	Setting Range	Initial Setting
n16	Accel Time 1	0.1s (less than 100s)	0 to 999	10s
n17	Decel Time 1			10s
n18	Accel Time 2	1.0s (100s or more)		10s
n19	Decel Time 2			10s

4.3.12 Soft-Start Characteristics (n20)

To prevent shock at machine start/stop, accel/decel can be performed in S-curve pattern.

Setting	S-Curve Characteristic Time
0	S-curve characteristic not provided
1	0.2 second
2	0.5 second
3	1.0 second

NOTE: S-curve characteristic time is the time from accel/decel rate 0 to a regular accel/decel rate determined by the set accel/decel time.

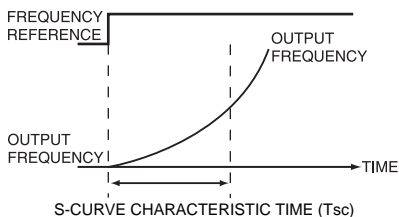

The following time chart shows FWD/REV run switching at deceleration to a stop.

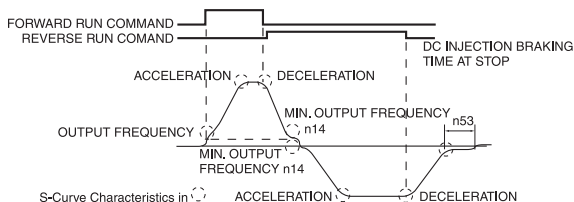

4.3.13 Setting Preset Speeds (n21 - n28)

By combining frequency reference and input terminal function selections, up to 16 steps of speed can be set.

8-Step Speed Change

n02 = 1 (operation mode selection)

n03 = 1 (Frequency reference selection)

n21 = 25Hz (Frequency reference 1)

n22 = 30Hz (Frequency reference 2)

n23 = 35Hz (Frequency reference 3)

n24 = 40Hz (Frequency reference 4)

n25 = 45Hz (Frequency reference 5)

n26 = 50Hz (Frequency reference 6)

n27 = 55Hz (Frequency reference 7)

n28 = 60Hz (Frequency reference 8)

n36 = 2 (Multi-function contact input terminal S2)

n37 = 6 (Multi-function contact input terminal S3)

n38 = 7 (Multi-function contact input terminal S4)

n39 = 9 (Multi-function contact input terminal S5)

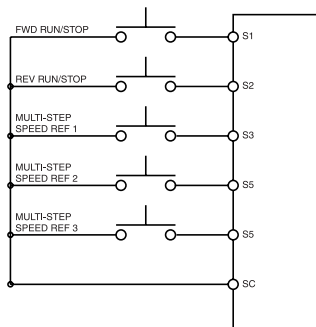

NOTE:

When all multi-function reference inputs are OFF, frequency reference selected by constant n03 (frequency reference selection) becomes effective.

n36 = 2 (Input terminal S2) Initial Setting

n37 = 6 (Input terminal S3) Change the setting to 6.

n38 = 7 (Input terminal S4) Change the setting to 7.

n39 = 8 (Input terminal S5) Change the setting to 8.

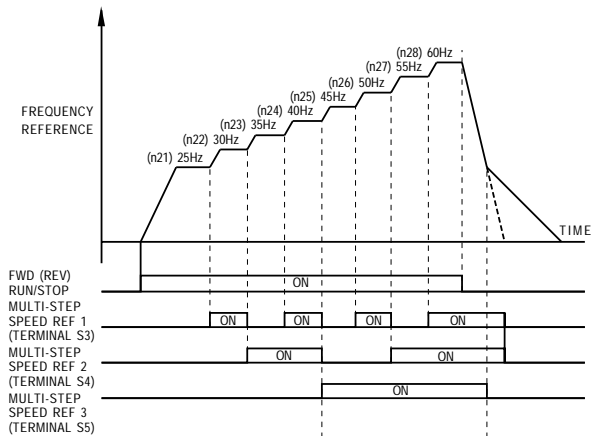

4.3.14 Operating at Low Speed (n29)

By inputting a jog command and then a forward (reverse) run command, operation is enabled at the jog frequency set in n29. When multi-step speed reference 1, 2, 3 or 4 are input simultaneously with jog command, the jog command has priority.

Name	Constant No.	Setting
Jog frequency reference	n29	Factory setting : 6Hz
Jog Command	n36 to n39	Set to "10" for any constant

4.3.15 Adjusting Freq. Upper/Lower Limits (n30-n31)

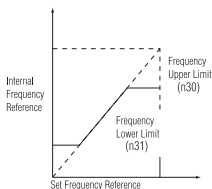

- Frequency reference upper limit (n30)
Sets the upper limit of the frequency reference in units of 1% .
(n09 : Maximum output frequency = 100%)
* Factory setting : 100%
- Frequency reference lower limit (n31)
Sets the lower limit of the frequency reference in units of 1%.
(n09 : Maximum output frequency = 100%)
When operating at frequency reference 0, operation is continued at the frequency reference lower limit.
However, when frequency reference lower limit is set to less than the minimum output frequency (n14), operation is not performed.
* Factory setting : 100%

4.3.16 Motor Protection (n32)

Motor Overload Detection

The VM7 protects against motor overload with a built-in electronic thermal overload relay.

- Motor rated current (n32)
Set to the rated current value shown on the motor nameplate.
NOTE: Setting to 0.0A disables the motor overload protective function.
- Motor overload protection selection (n33, n34)

n33 Setting	Electronic Thermal Characteristics
0	Applied to general-purpose motor, standard ratings
1	Applied to inverter motor
2	Electronic thermal overload protection not provided

The electronic thermal overload function monitors motor temperature, based on inverter output current and time, to protect the motor from overheating. When electronic thermal overload relay is enabled, an “**oL1**” error occurs, shutting OFF the inverter output and preventing excessive overheating in the motor. When operating with one inverter connected to one motor, an external thermal relay is not needed. When operating several motors with one inverter, install a thermal relay on each motor.

Constant No.	Name	Unit	Setting Range	Initial Setting
n34	Protection constant selection	1 min	1 to 60 min	8 min

Inverter Motor

- Cooling Effect
Effective even when operated at low speed (approx. 6Hz)
- Torque Characteristics
Use an inverter motor for continuous operation at low speed.
- Electronic Thermal Overload
Electronic thermal overload protection not activated even when continuously operated at 50/60Hz or less at 100% load.

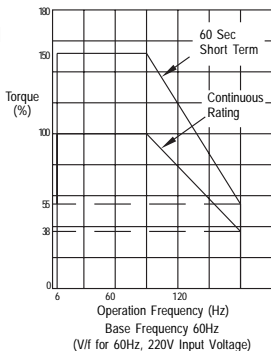

• **General-purpose motor and inverter motor**

Induction motors are classified as general-purpose motors or inverter motors, based on their cooling capabilities. Therefore, the motor overload function operates differently between these two motor types.

General-Purpose Motor

- Cooling Effect
Effective when operated at 50/60Hz from commercial power supply.
- Torque Characteristics
For low-speed operation, torque must be limited in order to stop motor temperature rise.
- Electronic Thermal Overload
“oL1” error (motor overload protection) occurs when continuously operated at 50/60Hz or less at 100% load.

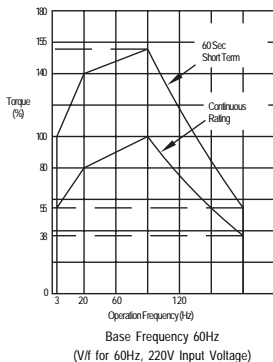

4.3.17 Selecting Cooling Fan Operation (n35)

In order to increase lifetime, the cooling fan can be set to operate only when inverter is running.

n35 = 0 (factory setting) : Operates only when inverter is running (continues operation for 1 minute after inverter is stopped).

= 1 : Operates with power ON.

4.4 SECOND FUNCTIONS

4.4.1 Building Interface Circuits with External Devices

Using Input Signals

Multi-function input terminal S1 to S5 functions can be changed when necessary by setting constants n36 or n37 respectively. The same value cannot be set to different constant settings.

Setting	Name	Description	Ref.
0	FWD/REV Run Command (3-wire sequence selection)	Setting enabled only for n37	4-21
2	Reverse Run (2-wire sequence selection)		4-22
3	External Fault (NO contact input)	Inverter stops by external fault signal input. Digital operator display is EF_*.	
4	External Fault (NC contact input)		
5	Fault Reset	Resets the fault. Fault reset not effective with the run signal ON.	4-27
6	Multi-Step Speed Reference 1		
7	Multi-Step Speed Reference 2		
8	Multi-Step Speed Reference 3		
10	JOG Command		4-28
11	Accel/Decel Time Select		4-25
12	External Baseblock (NO contact input)	Motor coasts to a stop by this signal input. Digital operator display is bb	
13	External Baseblock (NC contact input)		
14	Search Command from Maximum Frequency	Speed search reference signal	4-33
15	Search Command from Set Frequency		
16	Accel/Decel Hold Command		4-33:39
17	LOCAL/REMOTE Selection		4-7
18	Communication/Control Circuit Terminal Selection		4-51
19	Emergency Stop Fault (NO contact input)	Inverter stops by emergency stop signal input according to stopping method selection (n04). When frequency coasting to a stop (n04 is set to 1) method is selected, inverter coasts to a stop according to decel time setting 2 (n19). Digital operator display is Srp. (lit at fault, blinking at alarm)	
20	Emergency Stop Alarm (NO contact input)		
21	Emergency Stop Fault (NC contact input)		
22	Emergency Stop Alarm (NC contact input)		
34	UP/DOWN Command	Setting enabled only for n39 (terminal S5)	4-22,48
35	Self-Test	Setting enabled only for n39 (terminal S5)	

*Numbers 2 to 5 is displayed in corresponding to the terminal numbers S2 to S5 respectively.

Holding accel/decel temporarily

To hold acceleration or deceleration, input accel/decel hold command. The output frequency is maintained when the accel/decel hold command is input during acceleration or deceleration.

The stop command releases the accel/decel and the operation ramps to stop.

Set multi-function input terminal selection (n36 to n39) to 16 (accel/decel hold command).

Note: When the FWD (REV) run command is input along with the accel/decel hold command, the motor does not operate. However, when frequency reference lower limit (n31) is set greater than or equal to minimum output frequency (n14), the motor operates at frequency reference lower limit (n31).

Operating a coasting motor without trip

To operate coasting motor without trip, use the speed search command or DC injection braking at start.

• **Speed search command**

Restarts a coasting motor without stopping it. This function enables smooth switching between motor commercial power supply operation and inverter operation.

Set input terminal function selection (n36 to n39) to "14" (search command from maximum output frequency) or "15" (search command from set frequency).

Build a sequence so that FWD (REV) run command is input at the same time as the search command or after the search command. If the run command is input before the search command, the search command becomes disabled.

Reset the fault

Fault reset not effective with the run signal ON.

No.	Terminal	Initial Setting
n36	S2	2
n37	S3	5
n38	S4	3
n39	S5	6

Using Output Signal (n40)

Multi-function output terminal MA and MB functions can be changed when necessary by setting constants n40.

- Terminal MA and MB functions : Set to n40

Initial setting of multi-function output terminal

No.	Terminals	Initial Setting
n40	MA, MB	1 (in operation)

- Frequency agreed signal (setting = 2)

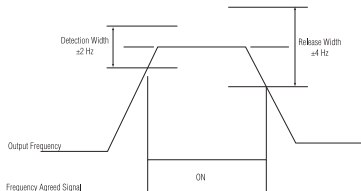

Setting	Name	Description	Ref. Page
0	Fault	Closed when inverter fault occurs.	-
1	In Operation	Closed when either FWD/REV command is input or voltage is output from the inverter.	-
2	Agreed Frequency	Closed when setting frequency agrees with inverter output frequency	-
3	Zero Speed	Closed when inverter output frequency is less than minimum output frequency	-
4	Frequency Detection 1	Output frequency \geq frequency detection level (n58).	4-46
5	Frequency Detection	Output frequency \leq frequency detection level (n58).	
6	Overtorque Detection (NO contact output)	-	4-47
7	Overtorque Detection (NC contact output)	-	
10	Minor Fault	Closed when the alarm is indicated.	-
11	Base Blocked	Closed when the inverter output is shut off.	-
12	Operation Mode	Closed when "LOCAL" is selected by LOCAL/REMOTE selection.	4-7
13	Inverter Operation Ready	Closed when inverter fault is not detected, and operation is ready.	-
14	Fault Restart	Closed during fault retry.	-
15	In UV	Closed when undervoltage is detected.	-
16	In Reverse Run	Closed during reverse run.	-
17	In Speed Search	Closed when inverter conducts speed search.	4-33
18	Data Output from Communication	Operates multi-function output terminal independently from inverter operation (by MODBUS communications).	4-51

4.4.2 Adjusting Freq. Reference Signal (n41, n42)

To provide frequency reference by analog input of control circuit terminal FR or FC, the relationship between analog input and frequency reference can be set.

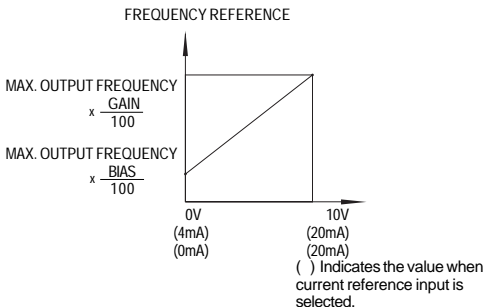

(a) Frequency reference gain (n41)

The analog input voltage value for the maximum output frequency (n09) can be set in units of 0.01 times.

(n09 maximum output frequency = 100%)

* Factory Setting : 100%

(b) Frequency reference bias (n42)

The frequency reference provided when analog input is 0V (4mA or 20mA) can be set in units of 1%.

(n09 maximum output frequency = 100%)

* Factory Setting : 0%

Typical Setting

- To operate the inverter with frequency reference of 50% to 100% at 0 to 5V input

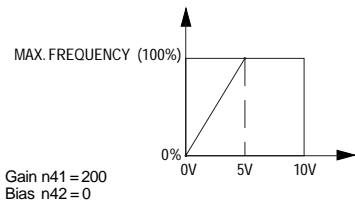

- To operate the inverter with frequency reference of 50% to 100% at 0 to 10V input

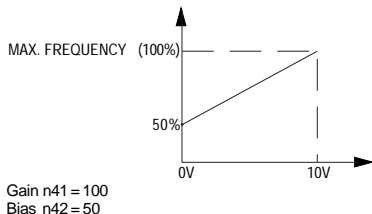

4.4.3 Using Frequency Meter or Ammeter (n44)

Selects to output either output frequency or output current to analog output terminals AM-AC for monitoring.

Setting	Description
0	Output Frequency
1	Output Current

In initial setting, analog voltage of approx. 10V is output when output frequency (output current) is 100%.

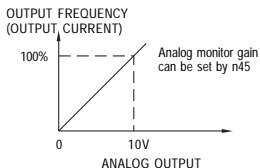
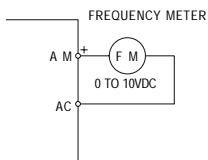

- **Calibrating Frequency Meter or Ammeter (n45)**

Used to adjust analog output gain

FREQUENCY METER/AMMETER
(3V 1mA FULL-SCALE)

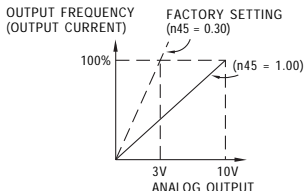
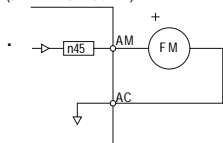

Set the analog output voltage at 100% of output frequency (output current). Frequency meter displays 0 to 60Hz at 0 to 3V.

$$10V \times \boxed{\begin{matrix} n45 \text{ Setting} \\ 0.30 \end{matrix}} = 3V \text{ Output frequency becomes } 100\% \text{ at this time.}$$

4.4.4 Reducing Motor Noise or Leakage Current (n46)

Set inverter output transistor switching frequency (carrier frequency).

Setting	Carrier Frequency (kHz)	Metallic Noise from Motor	Noise and Current Leakage
7	12 f _{out}	Higher	Smaller
8	24 f _{out}		
9	36 f _{out}		
1	2.5	Not Audible	Larger
2	5.0		
3	7.5		
4	10.0		

Setting values 7, 8 or 9 multiplies carrier frequency according to output frequency value.

n46 = 7

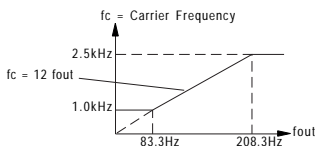

n46 = 8

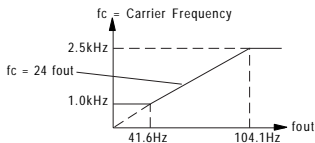

n46 = 9

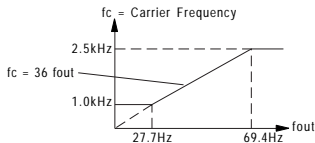

Chapter 4: Programming

Factory setting varies according to inverter capacity (kVA).

Voltage Class (V)	Capacity (kW)	Initial Setting		Maximum Continuous Output Current (A)*	Reduced Current
		Setting	Carrier Frequency		
200 Single-Phase 3-Phase	0.1	4	10kHz	0.8	-
	0.25	4	10kHz	1.6	
	0.55	4	10kHz	3.0	
	1.1	4	10kHz	5.0	
	1.5	3	7.5kHz	8.0	7.0
	2.2	3	7.5kHz	11.0	10.0
	3.7	3	7.5kHz	17.5	16.5
400 3-Phase	0.37	3	7.5kHz	1.2	1.0
	0.55	3	7.5kHz	1.8	1.6
	1.1	3	7.5kHz	3.4	3.0
	1.5	3	7.5kHz	4.8	4.0
	2.2	3	7.5kHz	5.5	4.8
	3.0	3	7.5kHz	7.2	6.3
	3.7	3	7.5kHz	9.2	7.6

NOTE:

(1) Reduce continuous output current when changing carrier frequency to 4 (10 kHz) for the 200V class (1.5 kW or more) and 400V class inverters. Refer to the table above for the reduced current. [Operation Condition]

- Input power supply voltage : 3-phase 200 to 230V (200V class)
Single-phase 200 to 240V (200V class)
3-phase 380 to 460V (400V class)
- Ambient temperature : 14 to 122°F (-10 to +50°C)

(2) If the wiring distance is long, reduce the inverter carrier frequency as described below.

Wiring Distance between Inverter and Motor	Up to 164 ft. (50m)	Up to 328 ft. (100m)	More than 328 ft. (100m)
Carrier Frequency (n46setting)	10kHz or less (n46 = 1, 2, 3, 4, 7, 8, 9)	5kHz or less (n46 = 1, 2, 7, 8, 9)	2.5kHz or less (n46 = 1, 7, 8, 9)

4.4.5 Auto-Restart After Momentary Power Loss (n47)

When momentary power loss occurs, operation restarts automatically.

Setting	Description
0	Continuous operation after momentary power loss not provided.
1*	Continuous operation after power recovery within momentary power loss ride thru time.
2*†	Continuous operation after power recovery (fault output not provided).

* Hold the operation command to continue the operation after recovery from a momentary power loss.

† When 2 is selected, operation restarts if power supply voltage reaches its normal level. No fault signal is output.

4.4.6 Continue Operation by Auto-Fault Reset (n48)

Sets the inverter to restart and reset fault detection after a fault occurs. The number of self-diagnosis and retry attempts can be set at n48 up to 10. The inverter will automatically restart after the following faults occur:

- OC (overcurrent)
- OV (overvoltage)
- GF (ground fault)

The number of retry attempts are cleared to 0 in the following cases:

- (1) If no other fault occurs within 10 minutes after retry.
- (2) When the fault reset signal is ON after the fault is detected.
- (3) Power supply is turned OFF.

4.4.7 Jump Frequencies (n49 to n51)

This function allows the prohibition or “jumping” of critical frequencies so that the motor can operate without resonance caused by machine systems. This function is also used for dead band control. Setting the value to 0.00Hz disables this function.

Set prohibited frequency 1, 2 or 3 as follows:

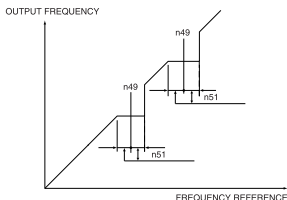

$$n49 \geq n50$$

If this condition is not satisfied the inverter displays “ERR” for one minute and restores the data to original settings.

4.4.8 Applying DC Injection Braking (n52 to n54)

- **DC injection braking current (n52)**

Sets DC injection braking current in units of 1%.
(Inverter Rated Current = 100%)

- **DC injection braking time at stop (n53)**

Sets the DC injection braking time at stopping in units of 0.1 second. When the setting of n53 is 0, DC injection braking is not performed but inverter output is shut OFF at the timing of DC injection braking start.

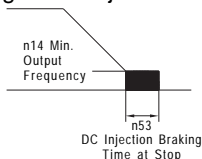

When coasting to a stop is specified in stopping method selection (n04), DC injection braking at stop does not operate.

•DC injection braking at start (n52, n54)

Restarts a coasting motor after stopping it. Set the DC injection braking time at start in n54 in units of 0.1 second. Set DC injection braking current in n52 in units of 1% (inverter rated current = 100%). When the setting of n54 is "0", DC injection braking is not performed and acceleration starts from the minimum output frequency.

When n52 is set to 0, acceleration starts from the minimum output frequency after the baseblocking for n54 setting time.

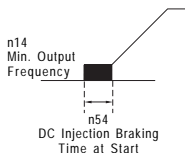

4.4.9 Stall Prevention During Decel (n55)

- (Current Limit) To prevent overvoltage during deceleration, the inverter automatically extends the deceleration time according to the value of main circuit DC voltage. When using an optional braking resistor, set n55 to 1.

Setting	Stall prevention (current limit) during deceleration
0	Provided
1	Not Provided

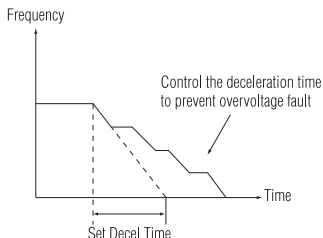

4.4.10 Preventing Motor from Stalling (n56)

(Current Limit) Automatically adjusts the output frequency and output current according to the load to continue operation without stalling the motor.

- **Stall prevention (current limit) level during acceleration (n56).** Sets the stall prevention (current limit) level during acceleration in units of 1%. (Inverter Rated Current =100%)
* Factory Setting : 170%

A setting of 200% disables the stall prevention (current limit) during acceleration. During acceleration, if the output current exceeds the value set for n56, acceleration stops and frequency is maintained. When the output current goes down to the value set for n56, acceleration starts.

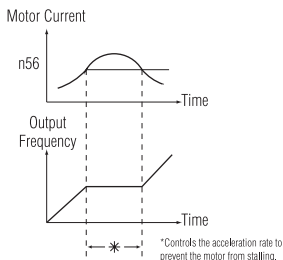

In the constant output area [output frequency \cong max. voltage output frequency (n11)], the stall prevention (current limit) level during acceleration is changed by the following equation.

$$\begin{aligned}
 & \text{Stall prevention (current limit) level during accel in constant output area} \\
 = & \text{Stall prevention (current limit) level during accel (n56)} \times \frac{\text{Max. voltage output frequency (n11)}}{\text{Output Frequency}}
 \end{aligned}$$

4.4.11 Stall Prevention During Run (n57)

- Sets the stall prevention (current limit) level during running in units of 1%.
(Inverter Rated Current = 100%)
* Factory Setting : 160%

A setting of 200% disables the stall prevention (current limit) during running.

During agreed speed if the output current exceeds the value set for n57, deceleration starts.

When the output current exceeds the value for n57, deceleration continues. When the output current goes down to the value set for n57, acceleration starts, up to the set frequency.

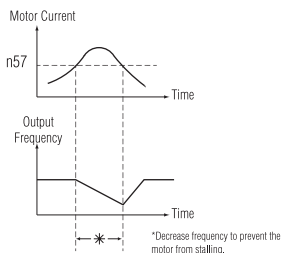

4.4.12 Frequency Detection (n58)

Effective when either of output terminal function selection n409 is set to "frequency detection" (setting: 4 or 5). "Frequency detection" turns ON when output frequency is higher or lower than the frequency detection level (n58).

- Frequency detection 1 (output frequency \geq frequency detection level) (Set n40 to "4")

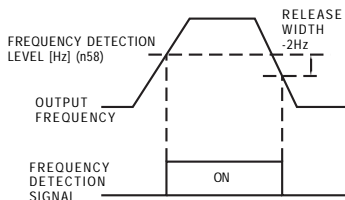

- Frequency detection 2 (output frequency \leq frequency detection level) (Set n40 to "5")

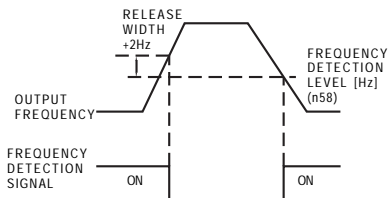

4.4.13 Torque Detection (n59 to n61)

If an excessive load is applied to the machine, output current increase can be detected to output alarm signals to multi-function output terminals MA and MB.

To output an overtorque detection signal, set output terminal function selection n40 to "overtorque detection" [Setting : 6 (NO contact) or 7 (NC contact)].

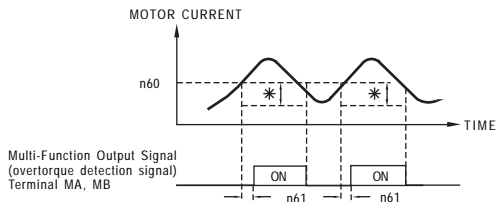

* Overtorque detection release width (hysteresis) is set at approx. 5% of inverter rated current.

- **Overtorque detection function selection 1 (n59)**

Setting	Description
0	Overtorque detection not provided.
1	Detected during constant-speed running, and operation continues after detection. (ALARM)
2	Detected during constant-speed running, and operation stops during detection. (FAULT)
3	Detected during running, and operation continues after detection. (ALARM)
4	Detected during running, and operation stops during detection. (FAULT)

- (1) To detect overtorque at accel/decel, set to 3 or 4.
- (2) To continue the operation after overtorque detection, set to 1 or 3. During detection, the operator displays "oL 3" alarm (blinking).
- (3) To halt the inverter by a fault at overtorque detection, set to 2 or 4. At detection, the operator displays "oL 3" fault (ON).

• Overtorque detection level (n60)

Sets the overtorque detection current level in units of 1%.

(Inverter Rated Current = 100%)

* Factory Setting : 160%

• Overtorque detection time (n61)

If the time when motor current exceeds the overtorque detection level (n60) is longer than overtorque detection time (n61), the overtorque detection function operates.

* Factory Setting : 0.1 sec.

4.4.14 Time Chart at UP/DOWN Command Input (n62)

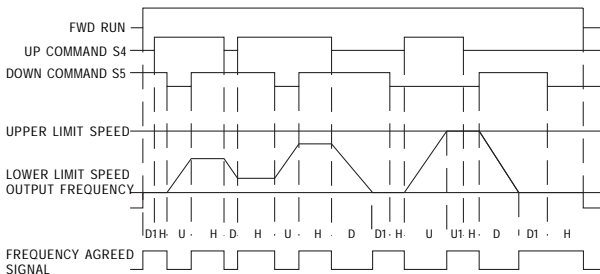

- U = UP (accelerating) status
- D = DOWN (decelerating) status
- H = HOLD (constant speed) status
- U1 = UP status, clamping at upper limit speed
- D1 = DOWN status, clamping at lower limit speed

NOTES:

1. When UP/DOWN command is selected, the upper limit speed is set regardless of frequency reference.

$$\text{Upper limit speed} = \text{Maximum output frequency (n09)} \times \text{Frequency reference upper limit (n30)/100}$$
2. Lower limit value is either minimum output frequency (n14) or frequency reference lower limit (n31)/100% (whichever is larger).
3. When the FWD (REV) run command is input, operation starts at the lower limit speed without an UP/DOWN command.
4. If the jog command is input while running by the UP/DOWN command, the jog command has priority.
5. Multi-step speed reference 1 to 4 is not effective when UP/DOWN command is selected. Multi-step speed reference is effective during running in hold status.
6. Output frequency is retained when hold reference memory selection (n62) is set to 1.

Setting	Description
0	Output frequency is not recorded during HOLD.
1	When HOLD status is continued for 5 seconds or longer, the output frequency during HOLD is recorded and the inverter restarts at the recorded frequency.

4.4.15 Holding Accel/Decel Temporarily

To hold acceleration or deceleration, input accel/decel hold command. The output frequency is maintained when the accel/decel hold command is input during acceleration or deceleration.

The stop command releases the accel/decel hold and the operation ramps to stop.

Set multi-function input terminal selection (n36to n39) to 16 (accel/decel hold command).

Time chart at accel/decel hold command input

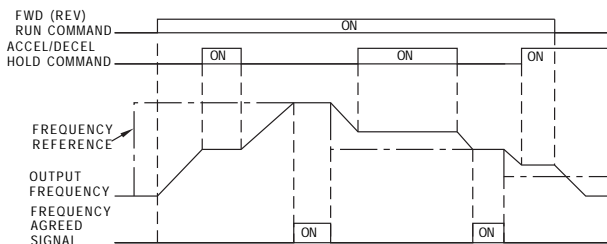

NOTE: When the FWD (REV) run command is input along with the accel/decel hold command, the motor does not operate. However, when frequency reference lower limit (n31) is set greater than or equal to minimum output frequency (n14), the motor operates at frequency reference lower limit (n31).

• **Auto Torque Boost (n63)**

Refer to page 4-15

4.4.16 Using MODBUS Communications (n68-n74)

Serial transmission is available with the VM7 via MODBUS protocol.

• MODBUS Communications

A MODBUS system is composed of a single master (PLC) and some number of slaves (1 to 31 VM7 units).

Communication between the master and the slave(s) (serial communication) is controlled by the master program with the master initiating communication and the slave responding to those requests.

The master sends a signal to one slave at a time. Each slave has a pre-registered address number. The master specifies the address number along with the transmitted data communication. The slave receives the communications to carry out designated functions and reply to the master.

Interface	RS-422, RS485
Synchronization	Asynchronous (Start-Stop synchronization)
Communication Parameters	Baud rate: Selected from 2400/4800/9600/19200 bps Data length: 8 bit fixed Parity: Selected from even/odd/none Stop bits: 1 bit fixed
Communication protocol	MODBUS (RTU mode only)
Max. number of inverters that can be connected	31 units (when using RS-485)

4.4.17 Using Constant Copy Function (n76-n77)

Constant Copy Function

The digital operator for remote operation (Part # JVOP-146, optional) can store constants for one inverter. A backup power supply is not necessary since EEPROM is used.

Note: When using a digital operator for remote operation, use with a remote interface unit for remote operation (optional) and the cable for remote interface (optional).

Constant copy function is possible only for the inverters with same product series and power supply specifications. However, some constants may not be copied. It is also impossible to copy constants between VSM and VM7 inverters.

The prohibition of the reading of constants from the inverter can be set at n77. The constant data cannot be changed when this constant is set.

- Constant copy function selection (n76)

Depending on the setting of n76 for constant copy function selection, the following functions are available.

- (1) Read all the constants from the inverter (READ) and store them in EEPROM in the digital operator.
- (2) Copies the constants stored in the digital operator to the inverter (COPY).
- (3) Verify the constants in the digital operator and the constants in the inverter are the same (VERIFY).
- (4) Displays the maximum applicable motor capacity and the voltage class of the inverter that has the constants stored in the digital operator.
- (5) Displays the software number of the inverter that has the constants stored in the digital operator.

Parameter No.	Name	Unit	Setting Range	Initial Setting
n76	Constant copy function selection	-	rdy: READY rEd: READ CPy: COPY vFy: VERIFY vA: Inverter capacity display Sno: Software No. display	rdy

• Prohibiting constant read selection (n77)

Select this function to prevent accidentally overwriting the constants stored in EEPROM or in the digital operator. Reading is not possible when this constant is set to 0.

The constant data stored in the digital operator are safe from accidental overwriting.

When reading is performed while this constant is set to 0, PrE will blink. Press the DSPL or ENTER and return to the constant number display.

Parameter No.	Name	Unit	Setting Range	Initial Setting
n77	Constant read selection prohibit	1	0: READ prohibited 1: READ allowed	0

READ (Upload) Function

Reads out the constants in batch from the inverter and stores them in EEPROM inside the digital operator. When the readout is executed, the previously stored constants data in the EEPROM are cleared and replaced with the newly entered constants.

Example: Store the constants read out from the inverter, in the EEPROM inside the digital operator.

	Explanation	Operator Display
<ul style="list-style-type: none"> · Enable the setting of the constants n01 to n79 	<ul style="list-style-type: none"> · Press DSPL to light [PRGM] · Press ENTER to display the set value · Change the set value to 4 by pressing ▲ or ▼ key. · Press ENTER. 	<p>n01 (Can be a different constant No.)</p> <p>0 (Lit) (Can be a different set value)</p> <p>1 (Blinks)</p> <p>1 (Lit for one second)</p>
<ul style="list-style-type: none"> · Set constant read prohibited selection (n77) to READ enabled. *1 	<ul style="list-style-type: none"> · Change the constant NO. to n77 by pressing ▲ or ▼ key. · Press ENTER to display the set value. · Change the set value to 1 by pressing the ▲ or ▼ key. · Press ENTER. 	<p>n77</p> <p>0 (Lit)</p> <p>1 (Blinks)</p> <p>1 (Lit for one second)</p> <p>n77 (The constant displayed)</p>
<ul style="list-style-type: none"> · Execute parameter upload (READ) by constant copy Function n76. 	<ul style="list-style-type: none"> · Change the constant No. by pressing ▲ or ▼ key. · Press ENTER to display the set value. · Change the set value to rEd by pressing ▲ or ▼ key. · Press ENTER · Press DSPL or ENTER 	<p>n76</p> <p>RDY (Lit)</p> <p>rEd (Lit)</p> <p>rEd (Blinks while executing READ)</p> <p>END (End is displayed after the execution of READ is completed)</p> <p>n76 (The constant is displayed)</p>
<ul style="list-style-type: none"> · Set constant read prohibited selection (n77) to READ disabled. *2 	<ul style="list-style-type: none"> · Change the constant number to n77 by pressing ▲ or ▼ key. · Press ENTER to display the set value. · Change the set value to 0 by pressing ▲ or ▼ key. · Press ENTER 	<p>n77</p> <p>1 (Lit)</p> <p>0 (Blinks)</p> <p>0 (Lit for one minute)</p> <p>n77 (The constant number is displayed)</p>

*1 When READ is enable (n77 = 1), this setting is not necessary.

*2 The setting is not necessary unless READ prohibition is selected.

COPY (Download) Function

Writes the constants stored inside the digital operator in batch to the inverter. Write-in is possible only for the inverters with same product series and power supply specifications.

Therefore, writing from 200 V class to 400 V class (or vice versa), from V/f control mode to vector control mode (or vice versa), and from VSM or VM7 are not possible.

Constant Copy Function Selection (n76), Constant Read Selection Prohibit (n77), Fault History (n78), Software version (n79), and hold output frequency are not written.

vAE will appear (blinking) when the capacity of the inverters differs.

Press ENTER to continue writing in (the COPY function).

Press STOP/RESET to stop the COPY function.

Following constants are not written if the inverter capacity is different.

Constant No.	Name	Constant No.	Name
n09 to n15	V/f setting	n64	Motor rated slip
n32	Motor rated current	n65	Motor no-load current
n46	Carrier frequency selection		

Example: Write the constants from EEPROM inside the digital operator to the inverter.

	Explanation	Operator Display
<ul style="list-style-type: none"> • Enable the setting for the constants n01 to n79 	<ul style="list-style-type: none"> • Press DSPL to light [PRGM] • Press ENTER to display the set value. • Change the set value to 4 by pressing ▲ or ▼ key. • Press ENTER. 	<p>n01 (Can be a different constant No.)</p> <p>0 (Lit) (Can be a different set value)</p> <p>1 (Blinks)</p> <p>1 (Lit for one second)</p> <p>n01 (The constant No. is displayed)</p>
<ul style="list-style-type: none"> • Execute download (COPY) by constant copy function (n76) 	<ul style="list-style-type: none"> • Change the constant No. to n76 by pressing ▲ or ▼ key. • Press ENTER to display the set value. • Change the set value to CPy by pressing ▲ or ▼ key. • Press ENTER • Press DSPL or ENTER 	<p>n76</p> <p>naY (Lit)</p> <p>CPy (Lit)</p> <p>CPy (Blinks while executing CPY)</p> <p>End (End is displayed when the execution of CPY is completed)</p> <p>n76 (The constant No. is displayed)</p>

A setting range check and matching check for the written-in constants are executed after the constants are copied from the digital operator to the inverter. If any constant error is found, the written constants are discarded and the previous are retained.

When a setting range error is found, the constant number where an error occurs is indicated by blinking.

When a matching error is found, **oP** (: a number) is indicated by blinking.

VERIFY Function

This function correlates the constants stored in the digital operator with the constants in the inverter. As well as download, VERIFY is possible only for the inverters with same product series, power supply specifications and control mode (V/f control or vector control).

When the constants stored in the digital operator match those in the inverter, vFy is displayed by blinking, the End is displayed.

Example: Correlate the constants stored in EEPROM inside the digital operator with the constants in the inverter.

Explanation	Operator Display
<ul style="list-style-type: none"> • Enable the setting for the constants n01 to n79 	<ul style="list-style-type: none"> - Press DSPL to light [PRGM] - Press ENTER to display the set value. - Change the set value to 4 by pressing ▲ or ▼ key. - Press ENTER. <p>n01 (Can be a different constant No.)</p> <p>0 (Lit) (Can be a different set value)</p> <p>1 (Blinks)</p> <p>1 (Lit for one second)</p> <p>n01 (The constant No. is displayed)</p>
<ul style="list-style-type: none"> • Execute VERIFY by constant copy function selection (n76) 	<ul style="list-style-type: none"> - Change the constant No. to n176 by pressing ▲ or ▼ key. - Press ENTER to display the set value. - Change the set value to vFy pressing ▲ or ▼ key. - Press ENTER <p>n76</p> <p>nY (Lit)</p> <p>vFy (Lit)</p> <p>vFy (Blinks while executing VERIFY)</p>
<ul style="list-style-type: none"> • Display the unmatched constant No. • Display the constant value in the inverter • Display the constant value in the digital operator. • Continue the execution of VERIFY. 	<ul style="list-style-type: none"> - Press ENTER - Press ENTER - Press ▲ key. - Press DSPL or ENTER <p>n09 (Blinks) (When n09 is unmatched)</p> <p>60.0 (Blinks)</p> <p>50.0 (Blinks)</p> <p>vFy (Blinks while executing VERIFY)</p> <p>End (End is displayed when the execution of VERIFY is completed)</p> <p>n76 (The constant No. is displayed)</p>

While an unmatched constant number is displayed or a constant value is displayed pressing STOP/RESET interrupts the execution of VERIFY and End is displayed. Pressing DSPL or ENTER returns to the constant number.

Chapter 4: Programming

Inverter Capacity Display

The voltage class and maximum applicable motor capacity (whose constants stored in the digital operator are read out) are displayed.

Example: Display the voltage class and maximum applicable motor capacity for the inverter whose constants stored in EEPROM inside the digital operator.

Explanation	Operator Display
<ul style="list-style-type: none"> Enable the setting for the constants n01 to n79 	<ul style="list-style-type: none"> Press DSPL to light [PRGM] Press ENTER to display the set value. Change the set value to 4 by pressing ▲ or ▼ key. Press ENTER.
<ul style="list-style-type: none"> Execute Inverter Capacity Display (vA) by constant copy function selection (n76) 	<ul style="list-style-type: none"> Press DSPL or ENTER.

The following shows the explanation of Inverter Capacity Display

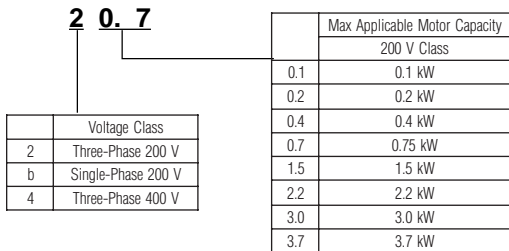

Software Number Display

The software version number (of the inverter whose constants stored in the digital operator are read out) is displayed.

Example: Display the software number of the inverter whose constants stored EEPROM inside the digital operator.

Explanation	Operator Display
<ul style="list-style-type: none"> Enable the setting for the constants n01 to n79 	<ul style="list-style-type: none"> Press DSPL to light [PRGM] Press ENTER to display the set value. Change the set value to 4 by pressing ▲ or ▼ key. Press ENTER.
<ul style="list-style-type: none"> Execute Software No. Display (Sno)* by constant copy function selection (n76). 	<ul style="list-style-type: none"> Change the constant No. to n76 by pressing ▲ or ▼ key. Press ENTER to display the set value. Change the set value to vA by pressing ▲ or ▼ key. Press ENTER Press DSPL or ENTER.

*Displays last 3 digits of the software version.

Chapter 4: Programming

Display List

Operator Display	Description	Corrective Action
rdY	Lit: Setting for constant copy function selection enabled	-
rEd	Lit: READ selected Flashed: READ under execution	-
CPy	Lit: Writing (COPY) selected	-
vFy	Lit: VERIFY selected Flashed: VERIFY under execution	-
vA	Lit: Inverter capacity display selected	-
Sno	Lit: Software No. display selected	-
End	Lit: READ, COPY (writing) or VERIFY completed	-
PrE	Blinks: Attempt to execute READ while Constant Read Prohibited Selection (n77) is set to 0.	Confirm the necessity to execute READ, then set constant Read Prohibited Selection (n77) to 1 to execute READ.
rdE	Blinks: The constant could not be read properly by READ operation. Or, a main circuit low voltage is detected during READ operation.	Confirm that the main circuit power supply voltage is correct, then re-execute READ.
CSE	Blinks: A check sum error occurs in the constant data stored in the digital operator.	The constants stored in the digital operator cannot be use. Re-execute READ to store the constants in the digital operator.
dPS	Blinks: A download has been attempted from one model inverter to a different model.	Check if they are the same product series.
rdR	Blinks: No constant data stored in the digital operator.	Execute READ.
CPE	Blinks: Attempt to execute writing (COPY) or VERIFY between different voltage classes or different control modes.	Check each voltage class and control mode.
CYE	Blinks: A main circuit low voltage is detected during writing (COPY) operation.	Confirm that the main circuit power supply voltage is correct, the re-execute writing (COPY).
F04	Lit: A check sum error occurs in the constant data stored in the inverter.	Initialize the constants. If an error occurs again, replace the inverter due to a failure of constant memory element (EEPROM) in the inverter.
vrE	Blinks: Attempt to execute VERIFY between different inverter capacities.	Press ENTER to continue the execution of VERIFY. Press STOP to interrupt the execution of VERIFY.
rFE	Blinks: A communication error occurs between the inverter and the digital operator.	Check the connection between the inverter and the digital operator. If a communication error occurs during READ operation or writing (COPY) operation, be sure to re-execute READ or COPY.

Note: While rEd, CPy, or vFy is displayed by blinking, key input on the digital operator is disabled. While rEd, CPy and vFy are not displayed by blinking, pressing DSPL or ENTER redisplay the constant number.

Chapter 5: PM/ Troubleshooting

What this chapter tells you:

- 1) Periodic inspection.
- 2) Operational faults
- 3) Alarm and fault codes.



Never touch the high voltage terminals in the inverter. Replace all protective covers before powering up the inverter. Only authorized personnel should be permitted to perform service on this unit.

5.0 PERIODIC INSPECTION

The VM7 will provide a long, useful operational life when you observe all of the precautions in this manual. It is, however, a good idea to perform regular, periodic inspections to make sure there are no unexpected problems. These checks are very simple and will not require much time. Table 5.1 on the page 5-3 summarizes the recommended checks.

5.1 OPERATIONAL FAULTS

The VM7 gives advanced diagnostic displays to assist in the troubleshooting of operational problems. Some problems, however, may not result in a unit fault trip. (Refer to Table 5.2 on page 5-4) for typical corrective actions.

Table 5.1 Periodic Inspection

Component	Check	Corrective Action
External terminal, connectors, mounting screws	Loose terminals or connections	Secure (do not overtighten)
Heatsink	Build-up of dust, dirt or oil	Blow with clean, dry compressed air
Printed Circuit Board	Accumulation of dust or dirt or discoloration	Clean with clean, dry compressed air. If problem persists, replace component.
Power Components		
Bus Capacitor	Discoloration, odor, discharge	Replace the capacitor or the inverter

Table 5.2 Operational Problems

Observed Problem	Check	Corrective Action
No keypad illumination	Incoming power supply	Measure input voltage and make sure it is within unit tolerance.
	DC Bus Voltage	Verify DC bus voltage is present. (320 VDC - 650 VDC)
Motor is turning wrong direction	T1, T2, T3 wiring	Reverse any two motor leads after power is removed and display is OFF.
	Control Wiring	Make sure control wiring is ok. Check programming of unit to be sure that 2-wire/3-wire programming is correct.
Keypad won't allow parameter changes	Check Access	<ol style="list-style-type: none"> 1. Must be in program mode. 2. Set parameter n01 for access.
Motor won't accelerate	Run LED	Make sure the drive is getting a valid run command
	LO/RE Status	Press LOCAL/REMOTE key
	Reference	Valid reference present
	Output Voltage	Check with rectifier type voltmeter. Look for balanced voltage.
	Fault Code	Refer to fault display tables, pages 5-6 thru 5-13
	Load	Make sure motor is not overloaded.
Motor current is high	Single-Phase	Use clamp on ammeter to verify balanced, three-phase output current.
	Motor connections	Is motor connected for correct voltage.
	V/Hz	Make sure the V/Hz pattern matches the motor nameplate.
	Load	Excessive load.

Replacement of Cooling Fan

• Inverter of W-Dimension (width) 2.68 inches

1. Removal

- (1) Press the right and left clicks of the fan cover and pull them to remove the fan cover from the inverter unit.
- (2) Pull the wiring from the fan cover rear face and remove the protective tube and connector.
- (3) Open the left and right sides of the fan cover to remove the cooling fan from cover.

2. Mounting

- (1) Mount the cooling fan on the fan cover. The arrow mark to indicate the wind direction of the cooling fan must be in the opposite side to the cover.
- (2) Connect the connector and mount the protective tube firmly. Mount the connector joint section on the fan cover rear face.
- (3) Mount the fan cover on the inverter. Be sure to mount the right and left clicks of the fan cover on the heatsink.

• Inverter of W-Dimension (width) 4.25 inches

1. Removal

- (1) Remove the front cover and terminal cover, and remove the cooling fan connector (CN4)
- (2) Press the right and left clicks of the fan cover and pull the fan cover to remove it from the inverter.
- (3) Open the right and left sides of the fan cover to remove the cover from the cooling fan.

2. Mounting

- (1) Mount the cooling fan on the fan cover. The arrow mark to indicate the wind direction must be opposite the cover.
- (2) Mount the fan cover on the inverter. Be sure to mount the right and left clicks of the fan cover on the heatsink. Lead in the wiring from the cable lead-in hole at the bottom of the plastic case to the inside of the inverter.
- (3) Connect the wiring to the cooling fan connector (CN4) and mount the front cover and the terminal cover.

5.3 ALARM and FAULT CODES

This section describes the alarm and fault displays, explanations for fault conditions and corrective actions to be taken if the VM7 malfunctions.



< Corrective Actions of Models with Digital Operator >



 : ON



 : BLINKING

 : OFF

Alarm Display and Contents





Alarm Display		Inverter Status	Explanation	Causes and Corrective Actions
Digital Operator	Run (Green) Alarm (Red)			
Uu Blinking		WARNING Fault contacts do not change state.	UV (Main circuit low voltage) Main circuit DC voltage drops below the low-voltage detection level while the inverter output is OFF 200V: Stops at main circuit DC voltage below approx. 200V (160V for single-phase) 400V: Stops at main circuit DC voltage below approx. 400V	Check the following: <ul style="list-style-type: none"> • Power supply voltage • Main circuit power supply wiring is connected • Terminal screws are securely tightened.
ou Blinking	 		OV (Main circuit over voltage) Main circuit DC voltage exceeds the overvoltage detection level while the inverter output is OFF. Detection level: approx. 410V or more (approx. 820V for 400V class).	Check the power supply voltage.
oH Blinking			OH (Cooling fin overheat) Intake air temperature rises while the inverter output is OFF.	Check the intake air temperature.
CAL Blinking			CAL (MODBUS communications waiting) Correct data has not been received from the PLC when the constants n02 (operation command selection) is 2 or n03 (frequency reference selection) is 6, and power is turned ON.	Check communication devices and transmission signals.





Alarm Display		Inverter Status	Explanation	Causes and Corrective Actions
Digital Operator	Run (Green) Alarm (Red)			
<p>OP Blinking</p>		<p>WARNING</p> <p>Fault contacts do not change state.</p>	<p>OP (Constant setting error when the constant setting is performed through the MODBUS communications.</p> <p>OP1: Two or more values are set for multi-function input selection. (constants n36 to n39)</p> <p>OP2: Relationship among V/f constants is not correct. (constants n11, n12, n14)</p> <p>OP3: Setting value of electronic thermal standard current exceeds 150% of inverter rated current. (constant n32)</p> <p>OP4: Upper/lower limit of frequency reference is reversed. (constants n30, n31)</p> <p>OP5: (constants n49 to n50)</p> <p>OP9: Carrier frequency setting is incorrect. (constant n46)</p>	<p>Check the setting values.</p>
<p>OL 3 Blinking</p>			<p>OL 3 (Overtorque detection) Motor current exceeded the preset value in constant n58.</p>	<p>Reduce the load, and expand the accel/decel time.</p>
<p>SEr Blinking</p>			<p>SER (Sequence error) Inverter receives LOCAL/REMOTE select command or communications/control circuit terminal changing signals from the multi-function terminal while the inverter is outputting.</p>	<p>Check the external circuit (sequence).</p>

Alarm Display		Inverter Status	Explanation	Causes and Corrective Actions
Digital Operator	Run (Green) Alarm (Red)			
BB Blinking		<p>WARNING</p> <p>Fault contacts do not change state.</p>	BB (External baseblock) Baseblock command at multi-function terminal is active, the inverter output is shut OFF (motor coasting). Temporary condition is cleared when input command is removed.	Check the external circuit (sequence).
EF Blinking			EF (Simultaneous FWD/REV run commands) When FWD and REV run commands are simultaneously input for over 500ms, the inverter stops according to constant n04.	Check the external circuit (sequence).
STP Blinking	 OR 		<p>STP (Operator function stop)  is pressed during running by the control circuit terminals FWD/REV command. The inverter stops according to constant n04.</p> <p>STP (Emergency stop) Inverter receives emergency stop alarm signal. Inverter stops according to constant n04.</p>	<p>Open FWD/REV command of control circuit terminals.</p> <p>Check the external circuit (sequence).</p>
FAN Blinking			FAN (Cooling fan fault) Cooling fan is locked.	Check the following: <ul style="list-style-type: none"> • Cooling fan • Cooling fan wiring is not connected.

Fault Display		Inverter Status	Explanation	Causes and Corrective Actions
Digital Operator	Run (Green) Alarm (Red)			
oC		Protective Operation ● ☀ Output is shut OFF and motor coasts to a stop.	OC (Overcurrent) Inverter output current momentarily exceeds approx. 200% of rated current.	<ul style="list-style-type: none"> Short circuit or grounding at inverter output side Excessive load GD^2 Extremely rapid accel/decel time (constants n19 to n22) Special motor used Starting motor during coasting Motor of a capacity greater than the inverter rating has been started Magnetic contactor open/closed at the inverter output side
GF			GF (Ground Fault) Ground fault current at the inverter output exceeded.	<ul style="list-style-type: none"> Check the motor insulation. Check that connection between inverter and motor is not damaged
ou			OV (Main circuit overvoltage) Main circuit DC voltage exceeds the overvoltage detection level because of excessive regenerative energy from the motor. Detection level: 200V: Stops at main circuit DC voltage below approx. 410V 400V: Stops at main circuit DC voltage approx. 820V or more	<ul style="list-style-type: none"> Insufficient decel time (constants n20 and n22) Lowering of minus load (elevator, etc) Increase decel time Connect optional braking resistor
Uu1		UV1 (Main circuit low voltage) Main circuit DC voltage drops below the low-voltage detection level while the inverter output is ON. 200V: Stops at main circuit DC voltage below approx. 200V (160V for single-phase) 400V: Stops at main circuit DC voltage approx. 400V or more	<ul style="list-style-type: none"> Reduction of input power supply voltage Open phase of input supply Occurrence of momentary power loss <p>Check the following:</p> <ul style="list-style-type: none"> Power supply voltage Main circuit power supply wiring is connected Terminal screws are securely tightened 	

Fault Display		Inverter Status	Explanation	Causes and Corrective Actions
Digital Operator	Run (Green) Alarm (Red)			
oH			OH (Cooling fin overheat) Temperature rise because of inverter overload operation or intake air temperature rise.	<ul style="list-style-type: none"> Excessive load Improper V/f pattern setting Insufficient accel time if the fault occurs during acceleration Intake air temperature exceeding 122°F (50°C) Check the following: <ul style="list-style-type: none"> Load size V/f pattern setting (constants n09 to n15) Intake air temperature
oL 1			OL1 (Motor overload) Motor overload protection operates by built-in electronic thermal overload relay.	<ul style="list-style-type: none"> Check the load size or V/f pattern setting (constants n09 to n15) Set the motor rated current shown on the nameplate by constant n32
oL 2			OL2 (Inverter overload) Inverter overload protection operates by built-in electronic thermal overload relay.	<ul style="list-style-type: none"> Check the load size or V/f pattern setting (constants n09 to n15) Check the inverter capacity
oL 3			OL3 (Overtorque detection) Inverter output current exceeded the preset value in constant (n60). When overtorque is detected, inverter performs operation according to the preset setting of constant n59.	Check the driven machine and correct the cause of the fault, or increase n060 up to the highest value allowed for the machine.

Fault Display		Inverter Status	Explanation	Causes and Corrective Actions
Digital Operator	Run (Green) Alarm (Red)			
EF 	 	Protective Operation Output is shut OFF and motor coasts to a stop	EF  (External fault) Inverter receives an external fault input from control circuit terminal. EF0: External fault reference through MEMOBUS communications EF2: External fault input command from control circuit terminal S2 EF3: External fault input command from control circuit terminal S3 EF4: External fault input command from control circuit terminal S4 EF5: External fault input command from control circuit terminal S5	Check the external circuit (sequence).
FO0			CPF-00 Inverter cannot communicate with the digital operator for 5 sec. or more when power is turned ON.	Cycle power after checking the digital operator is securely mounted. If the fault remains, replace the digital operator or inverter.
FO 1			CPF-01 Transmission fault occurred for 5 sec. or more when transmission starts with the digital operator.	Cycle power after checking the digital operator is securely mounted. If the faults remains, replace the digital operator or inverter.
FO 4			CPF-04 EEPROM fault of inverter control circuit is detected.	<ul style="list-style-type: none"> Record all constant data and initialize the constants. (refer to page 4-9 for constant initialization). Cycle power. If the fault remains, replace the inverter.

Fault Display		Inverter Status	Explanation	Causes and Corrective Actions
Digital Operator	Run (Green) Alarm (Red)			
FO 5		Protective Operation Output is shut OFF and motor coasts to a stop	CPF-05 AD converter fault is detected.	Cycle power. If the fault remains, replace the inverter.
FO 6			CPF-06 Option card connecting fault.	Remove power to the inverter. Check the connection of the digital operator.
FO 7			CPF-07 Operator control circuit (EEPROM or AD converter) fault.	Cycle power after checking the digital operator is securely mounted. If the fault remains, replace the digital operator or inverter.
CE			CE (MODBUS communications fault)	Check the communication devices or communication signals.
STP	 or 	Stops according to constants	STP (Emergency Stop) The inverter stops according to constant n04 after receiving the emergency stop fault signal.	Check the external circuit (sequence).
OFF			<ul style="list-style-type: none"> Insufficient power supply voltage Control power supply fault Hardware fault 	Check the following: <ul style="list-style-type: none"> Power supply voltage Main circuit power supply wiring is connected Terminal screws are securely tightened Control sequence Replace the inverter

For display/clear of fault history, refer to page 2-9.

Appendix A:

Parameter List

This Appendix provides a complete listing of the program parameters.

APPENDIX A: PARAMETER LIST

No.	Register No. for Transmission	Name	Setting Range	Setting Unit	Initial Setting	User Setting	Ref. Page
01	0101H	Password	0 to 4, 6, 8, 9	1	1		4-10
02	0102H	Run command selection	0 to 2	1	1		4-17
03	0103H	Frequency reference selection	0 to 6	1	2		4-18
04	0104H	Selecting stopping method	0, 1	1	0		4-23
05	0105H	Selecting reverse run prohibited	0, 1	1	0		4-24
06	0106H	Stop Key Function	0, 1	1	0		
07	0107H	Selecting frequency reference in local mode	0, 1	1	0 (Note 4)		4-7
08	0108H	Frequency reference setting method from digital operator	0, 1	1	0		4-8
09	0109H	Max. output frequency	50.0 to 400 Hz	0.1H (less than 100 Hz)	60.0 Hz		4-12
10	010AH	Max. voltage	1 to 255 V (Note 1)	0.1 V	230 V (Note 1)		
11	010BH	Max. voltage output frequency	0.2 to 400 Hz	1 Hz (100 Hz or more)	60.0 Hz		
12	010CH	Mid. output frequency	0.1 to 399		1.5 Hz		
13	010DH	Mid. output frequency voltage	1 to 255V (Note 1)	1 V	12 V (Note 1)		
14	010EH	Min. output frequency	0.1 to 10.0 Hz	0.1 Hz	1.5 Hz		
15	010FH	Min. output frequency voltage	1 to 50 V (Note 1)	0.1 V	12 V (Note 1)		
16	0110H	Acceleration time 1	0.0 to 999	0.1s (less than 100s) 1s (100s or more)	10.0s		4-25
17	0111H	Deceleration time 1	0.0 to 999				
18	0112H	Acceleration time 2	0.0 to 999				
19	0113H	Deceleration time 2	0.0 to 999				

No.	Register No. for Transmission	Name	Setting Range	Setting Unit	Initial Setting	User Setting	Ref. Page	
20	0114H	S-curve selection	0 to 3	1	0		4-26	
21	0115H	Frequency reference 1 (Master speed frequency reference)	0.0 to 400	0.1 Hz (less than 100 Hz) 1 Hz (100 Hz or more)	0.0 Hz		4-27	
22	0116H	Frequency reference 2	0.0 to 400		0.0 Hz			
23	0117H	Frequency reference 3	0.0 to 400		0.0 Hz			
24	0118H	Frequency reference 4	0.0 to 400		0.0 Hz			
25	0119H	Frequency reference 5	0.0 to 400		0.0 Hz			
26	011AH	Frequency reference 6	0.0 to 400		0.0 Hz			
27	011BH	Frequency reference 7	0.0 to 400		0.0 Hz			
28	011CH	Frequency reference 8	0.0 to 400		0.0 Hz			
29	011DH	Jog frequency	0.0 to 400		6.0 Hz			4-28
30	011EH	Frequency reference upper limit	0 to 100 %		1%	100%		
31	011FH	Frequency reference lower limit	0 to 110%	1%	0%			
32	0120H	Motor rated current	0 to 120% of inverter rated current	0.1 A	(Note 2)			
33	0121H	Electronic thermal motor protection selection	0 to 2	1	0		4-30	
34	0122H	Electronic thermal motor protection time constant setting.	1 to 60 min	1 min	8 min			
35	0123H	Selecting cooling fan operation	0, 1	1	0		4-31	
36	0124H	Multi-function input selection 2	2 to 8 10 to 22	1	2		4-32	
37	0125H	Multi-function input selection 3	0, 2 to 8 10 to 22	1	5			
38	0126H	Multi-function input selection 4	2 to 8 10 to 22	1	3			
39	0127H	Multi-function input selection 5	2 to 8, 10 to 22, 34, 35	1	6			

No.	Register No. for Transmission	Name	Setting Range	Setting Unit	Initial Setting	User Setting	Ref. Page
40	0128H	Multi-function output selection	0 to 7, 10 to 18	1	1		4-34
41	0129H	Analog frequency reference gain	0 to 255%	1%	100%		4-36
42	012AH	Analog frequency reference bias	-99 to 99%	1%	0%		
43	012BH	Filter time constant for analog frequency reference current	0.00 to 2.00s	0.01s			
44	012CH	Multi-function analog output (terminal AM-AC)	0, 1	1	0		4-38
45	012DH	Analog Monitor gain	0.00 to 2.00	0.01	1.00		
46	012EH	Carrier frequency selection	1 to 4, 7 to 9	1	(Note 3)		4-39
47	012FH	Momentary power loss ride through method	0 to 2	1	0		4-41
48	0130H	Automatic retry attempts	0 to 10 times	1	0 time		
49	0131H	Jump frequency 1	0.0 to 400 Hz	0.1Hz (less than 100 Hz) / 0.1Hz (100 Hz or more)	0.0 Hz		4-42
50	0132H	Jump frequency 2	0.0 to 400 Hz		0.0 Hz		
51	0133H	Jump frequency range	0.0 to 25.5 Hz		0.1 Hz	0.0 Hz	
52	0134H	DC injection braking current	0 to 100%	1%	50%		4-43
53	0135H	DC injection braking time at stop	0.0 to 25.5%	0.1s	0.0s		
54	0136H	DC injection braking time at start	0.0 to 25.5%	0.1s	0.0s		
55	0137H	Stall prevention during deceleration	0, 1	1	0		4-44
56	0138H	Stall prevention during acceleration	30 to 200%	1%	170%		
57	0139H	Stall prevention during running	30 to 200%	1%	160%		4-45

No.	Register No. for Transmission	Name	Setting Range	Setting Unit	Initial Setting	User Setting	Ref. Page
58	013AH	Frequency detection	0.0 to 400 Hz	0.1 Hz (less than 100 Hz) / 1 Hz (100 Hz or more)	0.0 Hz		4-46
59	013BH	Overtorque detection function	0 to 4	1	0		4-47
60	013CH	Overtorque detection level	30 to 200%	1%	160%		
61	013DH	Overtorque detection time	0.1 to 10.0s	0.1s	0.1s		
62	013EH	Hold output frequency saving selection	0, 1	1	0		
63	013FH	Torque compensation gain	0.0 to 2.5	0.1	1.0		4-15
64	0140H	Motor rated slip	0.0 to 20.0 Hz	0.1 Hz	(Note 2)		
65	0141H	Motor no-load current	0 to 99%	1%	(Note 2)		
66	0142H	Slip compensation gain	0.0 to 2.5	0.1	1.0		4-16
67	0143H	Slip compensation time constant	0.0 to 25.5s	0.1s	2.0s		4-15
68	0144H	Modbus timeover detection	0 to 4	1	0		4-51
69	0145H	Modbus frequency reference and frequency monitor unit	0 to 3	1	0		
70	0146H	Modbus slave address	0 to 32	1	0		
71	0147H	Modbus BPS selection	0 to 3	1	2		
72	0148H	Modbus parity selection	0 to 2	1	2		
73	0149H	Transmission waiting time	10 to 65 ms	1 ms	10 ms		
74	014AH	RTS control	0, 1	1	0		

No.	Register No. for Transmission	Name	Setting Range	Setting Unit	Initial Setting	User Setting	Ref. Page
75 #1	014BH	Reducing carrier frequency selection at low speed	0, 1	1	0		-
76 #1	014CH	Constant copy function selection	rdy, rEd, Cpy, vFy, vA, Sno		rdy		4-52
77 #1	014DH	Constant read selection prohibit	0, 1	1	0		4-53
78	014EH	Fault history	Stores, displays most recent alarm	Setting disabled	-		-
79	014FH	Software version No.	Displays lower-place 3 digits of software No.	Setting disabled	-		4-59

- Notes:
1. Upper limit of setting range and initial setting are doubled at 400 class.
 2. Changes depending on inverter capacity. Refer to the next page.
 3. Changes depending on inverter capacity. Refer to the next page
 4. Initial setting of the model with digital operator (without potentiometer) is 1. Setting can be set to 0 by constant initialization.

n 200 V Class 3-Phase										
No.	Name	Unit	Factory Setting							
-	Inverter capacity	kW	0.1kW	0.2kW	0.4kW	0.75kW	1.5kW	2.2kW	-	3.7kW
n32	Motor rated current	A	0.6	1.1	1.9	3.3	6.2	8.5	-	14.1
n64	Motor rated slip	Hz	2.5	2.6	2.9	2.5	2.6	2.9	-	3.3
n65	Motor no-load current	%	72	73	62	55	45	35	-	32
n 200 V Class Single-Phase										
No.	Name	Unit	Factory Setting							
-	Inverter capacity	kW	0.1kW	0.2kW	0.4kW	0.75kW	1.5kW	2.2kW	-	-
n32	Motor rated current	A	0.6	1.1	1.9	3.3	6.2	8.5	-	-
n64	Motor rated slip	Hz	2.5	2.6	2.9	2.5	2.6	2.9	-	-
n65	Motor no-load current	%	72	73	62	55	45	35	-	-
n 400 V Class 3-Phase										
No.	Name	Unit	Factory Setting							
-	Inverter capacity	kW	-	0.2kW	0.4kW	0.75kW	1.5kW	2.2kW	3.0kW	3.7kW
n32	Motor rated current	A	-	0.6	1.0	1.6	3.1	4.2	7.0	7.0
n64	Motor rated slip	Hz	-	2.5	2.7	2.6	2.5	3.0	3.2	3.2
n65	Motor no-load current	%	-	73	63	52	45	35	33	33

This page intentionally left blank.

5580 Enterprise Parkway, Fort Myers, Florida 33905
Telephone (941) 693-7200 · Fax (941) 693-2431
www.saftronics.com

REV 00 - 03/00
P/N 027-2060
Firmware: VSP010021