

FP5/GP5

TECHNICAL MANUAL



PREFACE

Saftronics' FP5/GP5 is the world's first optimized Inverter specifically designed for general-purpose applications. This manual describes installation, maintenance and inspection, troubleshooting, and specifications of the FP5/GP5. Read this manual thoroughly before operation.

General Precautions

- Some drawings in this manual are shown with the protective cover or shields removed, in order to describe detail with more clarity. Make sure all covers and shields are replaced before operating this product.
- This manual may be modified when necessary because of improvement of the product, modification, or changes in specifications. Such modifications are denoted by a revision number.
- To order a copy of this manual, contact your Saftronics representative.
- Saftronics is not responsible for any modification of the product made by the user, since that will void your warranty.



PREFACE

Notes for Safe Operation

Read this manual thoroughly before installation, operation, maintenance or inspection of the FP5/GP5. In this manual, notes for safe operation are classified as followed:



WARNING

Indicates a potentially hazardous situation which, if not avoided, could result in death or serious injury to personnel.



CAUTION

Indicates a potentially hazardous situation which, if not avoided, may result in minor or moderate injury to personnel and damage to equipment. It may also be used to alert against unsafe practices.

Even items described in CAUTION may result in a fatal accident in some situations. In either case, follow these important notes.

Take the following steps to ensure proper operation.

■ Receiving

 CAUTION	
	Page
<ul style="list-style-type: none"> Do not install or operate any Inverter that is damaged or has missing parts. Failure to observe this may result in personal injury or equipment damage. 	2

■ Installation

 CAUTION	
	Page
<ul style="list-style-type: none"> When moving the unit, lift the cabinet by the base, never lift by the front cover. Otherwise, the main unit may be dropped causing damage to the unit. Mount the Inverter on nonflammable material (i.e., metal). Failure to observe this can result in a fire. When mounting units in an enclosure, install a fan or other cooling device to keep the intake air temperature below 45°C. Overheating may cause a fire or damage the unit. 	6 6 6

■ Wiring

 WARNING	
	Page
<ul style="list-style-type: none"> Only commence wiring after verifying that the power supply is turned OFF. Failure to observe this warning can result in an electrical shock or fire. Wiring should be performed only by qualified personnel. Failure to observe this warning can result in an electrical shock or fire. When wiring the emergency stop circuit, check the wiring thoroughly before operation. Failure to observe this warning can result in personal injury. Make sure to ground the ground terminal (⊕). (Ground resistance 200V class: 100Ω or less, 400V class: 10Ω or less.) Failure to observe this warning can result in an electrical shock or fire. 	10 10 10 11



PREFACE

CAUTION	
	Page
• Verify that the Inverter rated voltage coincides with the AC power supply voltage. Failure to observe this can result in personal injury or fire.	10
• Do not perform a withstand voltage test on the Inverter. It may cause semi-conductor elements to be damaged.	10
• To connect a Braking Resistor, Braking Resistor Unit or Braking Unit, follow the procedures described in <i>Chapter 11</i> . Improper connection may cause a fire.	10
• Tighten terminal screws to the specified tightening torque. Failure to observe this can result in a fire.	10
• Never connect the AC main circuit power supply to output Terminals T1, T2, and T3 (U, V, and W). The Inverter will be damaged and invalidate the warranty.	11

■ **Operation**

WARNING	
	Page
• Only turn ON the input power supply after replacing the front cover. Do not remove the cover while current is flowing. Failure to observe this can result in an electrical shock.	24
• When the retry function (n057) is selected, do not approach the Inverter or the load, since it may restart suddenly after being stopped. (Construct machine system, so as to assure safety for personnel, even if the Inverter should restart.) Failure to observe this can result in personal injury.	24
• Since the stop button can be disabled by a function setting, install a separate emergency stop switch. Failure to observe this can result in personal injury.	24

CAUTION	
	Page
• Never touch the heatsink or discharging resistor since the temperature is very high. Failure to observe this can result in harmful burns to the body.	24
• Since it is easy to change operation speed from low to high speed, verify the safe working range of the motor and machine before operation. Failure to observe this can result in personal injury and machine damage.	24
• Install a holding brake separately, if necessary. Failure to observe this can result in personal injury.	24
• Do not change signals during operation. The machine or the Inverter may be damaged.	24
• All the constants of the Inverter have been preset at the factory. Do not change the settings unnecessarily. The Inverter may be damaged. For supply voltage, follow <i>Paragraph 4.3 of Chapter 4</i> .	24

PREFACE

■ Maintenance and Inspection

 WARNING		Page
•	Never touch high-voltage terminals in the Inverter. Failure to observe this can result in an electrical shock.	64
•	Replace all protective covers before powering up the Inverter. To remove the cover, make sure to shut OFF the Molded Case Circuit Breaker. Failure to observe this can result in an electrical shock.	64
•	Perform maintenance or inspection only after verifying that the CHARGE LED goes OFF, after main circuit power supply is turned OFF. The capacitors are still charged and can be dangerous.	64
•	Only authorized personnel should be permitted to perform maintenance, inspections or parts replacement. (Remove all metal objects (watches, bracelets, etc.) before operation. Use tools that are insulated against electrical shock.) Failure to observe this can result in an electrical shock.	64

 CAUTION		Page
•	The control PC board employs CMOS ICs. Do not touch the CMOS elements. They are easily damaged by static electricity.	64
•	Do not connect or disconnect wires or connectors while power is applied to the circuit. Failure to observe this can result in personal injury.	64

■ Others

 WARNING	
•	Never modify the product. Failure to observe this can result in an electrical shock or personal injury and will invalidate the warranty.



Table of Contents

1	Receiving	1
1.1	Inspection Checkpoints.....	2
1.1.1	Receiving Checkpoints.....	2
1.1.2	Checking the Nameplate Data.....	2
1.2	Identifying the Parts	2
2	Installation	5
2.1	Removing and Replacing the Digital Operator.....	6
2.1.1	Removing the Digital Operator	6
2.1.2	Replacing the Digital Operator.....	6
2.2	Removing and Replacing the Front Cover.....	7
2.3	Choosing a Location to Mount the Inverter	7
2.4	Clearances	8
3	Wiring	9
3.1	Connection Diagram	10
3.2	Wiring the Main Circuit.....	11
3.2.1	Wiring Precautions for Main Circuit Point.....	11
3.2.2	Wiring Precautions for Main Circuit Output	12
3.2.3	Grounding.....	12
3.2.4	Functions of Main Circuit Terminals	13
3.2.5	Main Circuit Configuration.....	15
3.2.6	Parts Required for Wiring.....	17
3.3	Wiring the Control Circuit	21
3.3.1	Functions of Control Circuit Terminals	21
3.3.2	Wiring the Control Circuit Terminals.....	22
3.3.3	Precautions on Control Circuit Wiring.....	22
3.4	Wiring Inspection	22
4	Operation	23
4.1	Operation Mode Selection.....	25
4.2	Test Run Checkpoints.....	26
4.3	Setting the Line Voltage Using Jumper (For 400V Class 18.5kW and Above)	26
4.4	Test Run.....	27
4.4.1	Digital Operator Display at Power-Up.....	27
4.4.2	Operation Check Points	28
4.4.3	Example of Basic Operation	28
5	Simple Data Setting.....	31
5.1	Digital Operator Key Description	32
5.2	LED Description.....	32
6	Programming Features	35
6.1	Constant Set-Up and Initialization	36
6.1.1	Constant Selection/Initialization (n001)	36
6.2	V/f Pattern Setting.....	36
6.2.1	Preset V/f Pattern	37
6.2.2	Custom V/f Pattern	38
6.3	Setting Operation Conditions	38
6.3.1	Reverse Run Prohibit (n006)	38
6.3.2	Multi-Step Speed Selection.....	38
6.3.3	Operation at Low Speed	39
6.3.4	Adjusting Frequency Setting Signal.....	40
6.3.5	Adjusting Frequency Upper and Lower Limits	41

6.3.6	Using Two Accel/Decel Times.....	41
6.3.7	Automatic Restart after Momentary Power Loss (n051)	42
6.3.8	Soft-Start Characteristics (n023)	42
6.3.9	Torque Detection.....	43
6.3.10	Frequency Detection (n073)	44
6.3.11	Jump Frequencies (n058 to n060)	44
6.3.12	Continuing Operation by Automatic Fault Reset (n056)	45
6.3.13	Operating Coasting Motor without Trip	45
6.3.14	Using Frequency Meter of Ammeter (n048).....	46
6.3.15	Calibrating Frequency Meter of Ammeter (n049)	46
6.3.16	Reducing Motor Noise or Leakage Current (n050).....	47
6.4	Selecting Stopping Method.....	48
6.4.1	Selecting Stopping Method (n004)	48
6.4.2	Coast to Stop with Timer 1 (n004=2)	49
6.4.3	Applying DC Injection Braking Current (n064).....	49
6.5	Building Interface Circuits with External Devices.....	50
6.5.1	Using Sequence Input Signals (n035 to n039)	50
6.5.2	Using Analog Input Signals (n042 to n045)	53
6.5.3	Using Output Signals (n040, n041)	55
6.6	Setting Operation Conditions.....	56
6.6.1	Torque Compensation Gain (n067).....	56
6.7	Motor Protection.....	57
6.7.1	Motor Overload Detection.....	57
6.8	PID Control	58
6.8.1	Intended Value Setting.....	58
6.8.2	Detected Value Setting	58
6.9	Energy Saving Control	59
6.9.1	Energy Saving Gain K2 (n096).....	59
6.9.2	Energy Saving Tuning.....	59
6.10	MEMOBUS Control	60
6.10.1	Communication Specifications	60
6.10.2	Data to be Sent/Received by Communication	60
7	Maintenance and Inspection	63
7.1	Periodic Inspector	64
7.2	Parts Replacement Schedule (Guidelines).....	64
8	Troubleshooting.....	65
8.1	Fault Diagnosis and Corrective Actions	66
8.2	Alarm Display and Explanation	69
8.3	Motor Faults and Corrective Actions	70
9	Specifications.....	71
9.1	Standard Specifications.....	72
10	Dimensions.....	75
10.1	Dimensions	76
11	Typical Connection Diagram.....	79
11.1	Braking Resistor Unit.....	80
11.2	Braking Unit and Braking Resistor Unit.....	81
12	Constant List.....	83
12.1	Constant List.....	84
13	Digital Operator Monitor Display	91
13.1	Digital Operator Monitor Display	92
INDEX.....		95



1

Receiving

This chapter describes how to inspect the inverter after delivery to the user.

1.1	Inspection Checkpoints.....	2
1.1.1	Receiving Checkpoints.....	2
1.1.2	Checking the Nameplate Data	2
1.2	Identifying the Parts.....	2



Chapter 1: Receiving

CAUTION

- Do not install or operate any Inverter which is damaged or has missing parts. Failure to observe this may result in personal injury or equipment damage.

1.1 Inspections Checkpoints

1.1.1 Receiving Checkpoints

Table 1 Checkpoints

Checkpoints	Description
Does the Inverter model number correspond with the purchase order?	Check the model number on the nameplate on the side of the FP5/GP5. (See below.)
Are any parts damaged?	Visually check the exterior and verify that there was no damage during transport.
Is hardware properly seated and securely tightened?	Remove Inverter front cover. Check all visible hardware with appropriate tools.
Was an instruction manual received?	FP5/GP5 Instruction Manual

If any of the above checkpoints are not satisfactory, contact your Safronics representative.

1.1.2 Checking the Nameplate Data

■ **Nameplate Data**

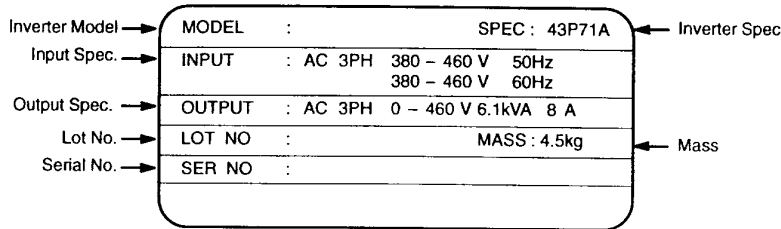

Figure 1 Nameplate Data

■ **Model Designation**

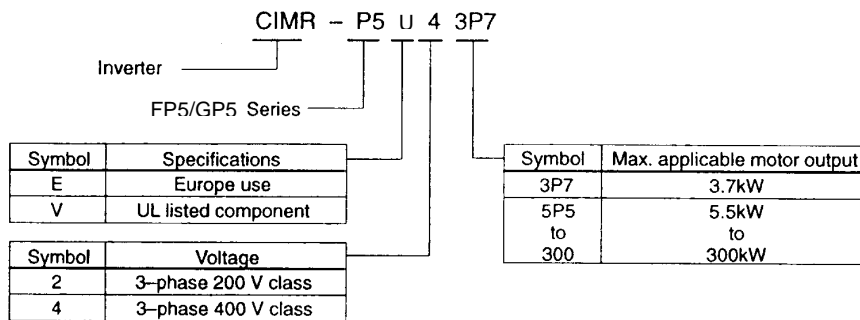
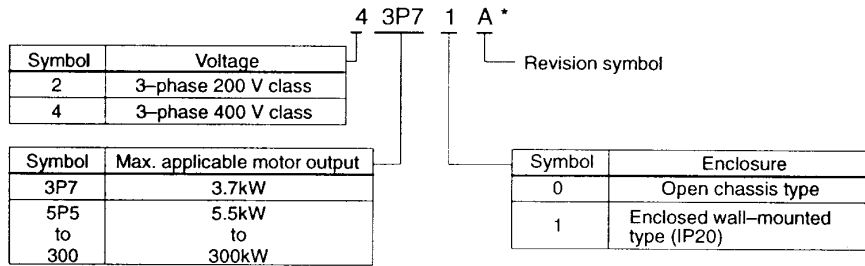

Figure 2 Model Designation



■ Specification Designation



* For special specifications, a spec sheet number appears on the nameplate.

Figure 3 Specification Designation

1.2 Identifying the Parts

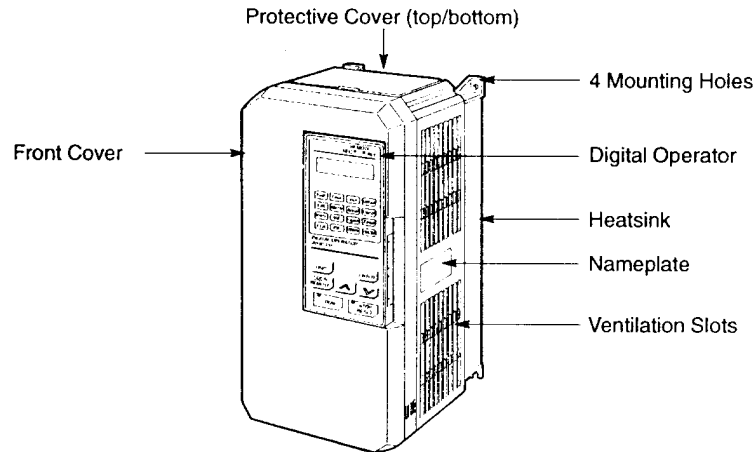

Figure 4 Configuration of FP5/GP5



Chapter 1: Receiving

NOTES:



2

Installation

This chapter describes configuration, location and clearances when mounting the FP5/GP5.

2.1	Removing and Replacing the Digital Operator	6
2.1.1	Removing the Digital Operator	6
2.1.2	Replacing the Digital Operator	6
2.2	Removing and Replacing the Front Cover	7
2.3	Choosing a Location to Mount the Inverter	7
2.4	Clearances	8



CAUTION

- When moving the unit, lift the cabinet by the base, never lift by the front cover. Otherwise, the main unit may be dropped causing damage to the unit.
- Mount the Inverter on nonflammable material, (i.e., metal). Failure to observe this can result in a fire.
- When mounting units in an enclosure, install a fan or other cooling device to keep the intake air temperature below 45°C. Overheating may cause a fire or damage to the unit.

2.1 Removing and Replacing the Digital Operator

Remove and replace the Digital Operator as follows:

2.1.1 Removing the Digital Operator

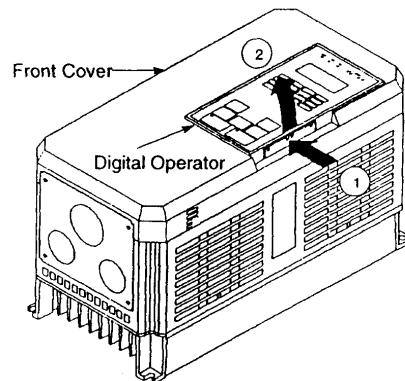

Figure 5 Removing the Digital Operator

To remove the Digital Operator from the front cover, push the Digital Operator lever in the direction shown by arrow 1 and lift the Digital Operator in the direction shown by arrow 2.

2.1.2 Replacing the Digital Operator

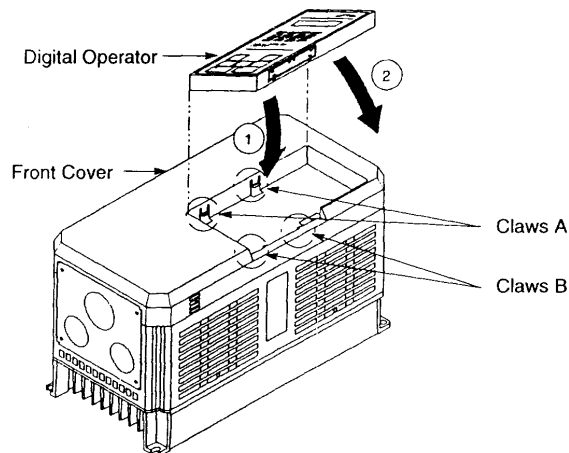

Figure 6 Replacing the Digital Operator

Engage the Digital Operator on claws A in the direction shown by arrow 1 and then on claws B in the direction shown by arrow 2 to lock the Digital Operator.

NOTE: Never fit the Digital Operator in any other direction or by any other method. The Digital Operator will not be connected to the Inverter.



2.2 Removing and Replacing the Front Cover

To remove the front cover, first move the Digital Operator in the direction shown by arrow 1. (Figure 5). Then squeeze the cover in the direction shown by arrows 2 on both sides and lift in the direction shown by arrow 3.

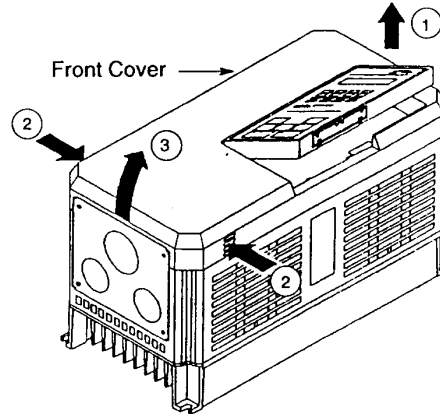

Figure 7 Removing and Replacing the Front Cover

NOTE: Do not replace the front cover with the Digital Operator connected. The Digital Operator will not be connected to the Inverter. Replace the front cover first and then install the Digital Operator on the cover. See Figure 6 for replacing the Digital Operator.

2.3 Choosing a Location to Mount the Inverter

To ensure proper performance and long operating life, follow the recommendations below when choosing a location for installing the FP5/GP5. Make sure the Inverter is protected from the following conditions:

- Extreme cold and heat. Use only within ambient temperature range: -10°C to $+40^{\circ}\text{C}$.
- Rain, moisture. (For enclosed wall-mounted type.)
- Oil sprays, splashes.
- Salt spray.
- Direct sunlight. (Avoid using outdoors.)
- Corrosive gases or liquids.
- Dust or metallic particles in the air. (For enclosed wall-mounted type.)
- Physical shock, vibration.
- Magnetic noise. (Example: welding machines, power devices, etc.)
- High humidity.
- Radioactive materials.
- Combustibles: thinners, solvents, etc.

2.4 Clearances

Install the FP5/GP5 vertically and allow sufficient clearances for effective cooling as shown below.

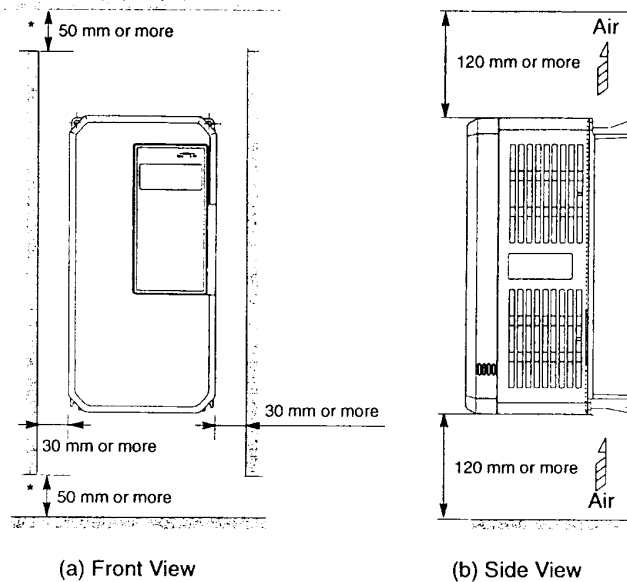

Figure 8 Clearances

- NOTE:**
- The clearances required at the top and bottom and both sides are common in open chassis type (IP00) and enclosed wall-mounted type (NEMA1/IP20).
 - Remove the top and bottom covers to use the open chassis type of 200V/400V 15kW or less.
 - When installing the models of 200V/400V 30kW or more equipped with eyebolts, extra spacing will be required on either side. For detailed dimensions, contact your Saftronics representative.
 - For the external dimensions and mounting dimensions, refer to *Chapter 10 Dimensions*.
 - Allowable intake air temperature to the Inverter:
 - Open chassis type (IP00) : - 10°C to 45°C
 - Enclosed wall-mounted type : - 10°C to 40°C (NEMA 1/IP20)
 - Ensure sufficient space for the sections at the upper and lower parts marked with * in order to permit the flow of intake/exhaust air to/from the Inverter.



3

Wiring

This chapter describes the main circuit wiring and the control circuit wiring of the FP5/GP5.

3.1	Connection Diagram	10
3.2	Wiring the Main Circuit	11
3.2.1	Wiring Precautions for Main Circuit Input	11
3.2.2	Wiring Precautions for Main Circuit Output.....	12
3.2.3	Grounding	12
3.2.4	Functions of Main Circuit Terminals.....	13
3.2.5	Main Circuit Configuration	15
3.2.6	Parts Required for Wiring	17
3.3	Wiring the Control Circuit	21
3.3.1	Functions of Control Circuit Terminals.....	21
3.3.2	Wiring the Control Circuit Terminals	22
3.3.3	Precautions on Control Circuit Wiring.....	22
3.4	Wiring Inspection	22

WARNING

- Only commence wiring after verifying that the power supply is turned OFF. Failure to observe this can result in an electrical shock or fire.
- Wiring should be performed only by qualified personnel. Failure to observe this can result in an electrical shock or fire.
- When wiring the emergency stop circuit, check the wiring thoroughly before operation. Failure to observe this can result in personal injury.

CAUTION

- Verify that the Inverter rated voltage coincides with the AC power supply voltage. Failure to observe this can result in personal injury or fire.
- Do not perform a withstand voltage test of the Inverter. It may cause semi-conductor elements to be damaged.
- To connect a Braking Resistor, Braking Resistor Unit or Braking Unit, follow the procedures described in *Chapter 11*. Improper connection may cause fire.
- Tighten terminal screws to the specified tightening torque. Failure to observe this can result in a fire.

3.1 Connection Diagram

Below is a connection diagram of the main circuit and control circuit. Using the Digital Operator, the motor can be operated by wiring the main circuit only.

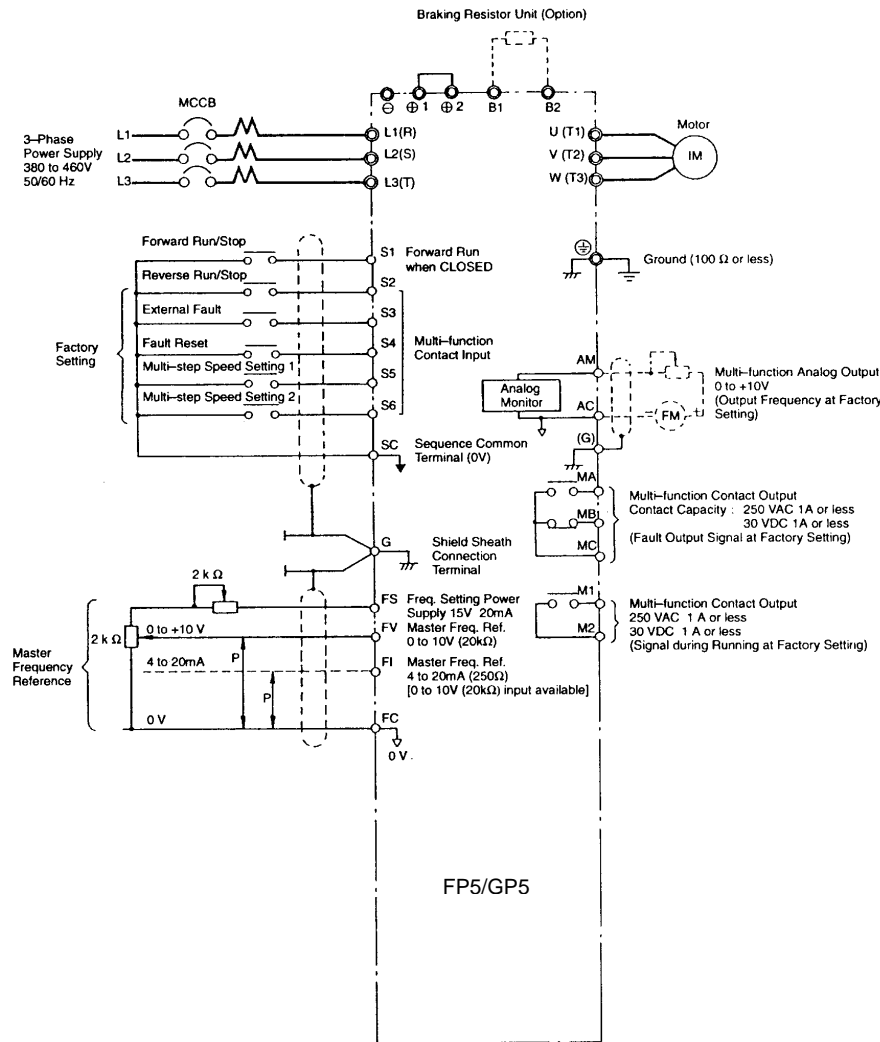



Figure 9 FP5/GP5 Connection Diagram

**NOTE:**

1.  indicates shielded wires and  indicates twisted-pair shielded wires.
2. Voltage or current input for the master frequency reference can be selected by constant n042. Voltage reference input is preset at the factory (FV).
3. Control circuit Terminal FS of + 15V has a maximum output current capacity of 20 mA.
4. Multi-function analog output should be used for monitoring meters (e.g., output frequency meter) and should not be used for feedback control system.

3.2 Wiring the Main Circuit



WARNING

- Make sure to ground the ground terminal (\oplus). (Ground resistance 200V class: 100 Ω or less, 400V class: 10 \times or less.) Failure to observe this can result in an electrical shock or a fire.



CAUTION

- Never connect the AC main circuit power supply to output Terminals T1, T2, and T3 (U, V and W). The Inverter will be damaged and invalidate the warranty.

3.2.1 Wiring Precautions for Main Circuit Input

■ Installation of Molded Case Circuit Breaker (MCCB)

Make sure to connect Molded Case Circuit Breakers (MCCB) or fuses between AC main circuit power supply and FP5/GP5 input Terminals L1, L2 and L3 (R, S, and T) to protect wiring.

■ Installation of Ground Fault Interrupter

When connecting a ground fault interrupter to input Terminals L1, L2 and L3 (R, S, and T), select one that is not affected by high frequency.

Examples: NV series by Mitsubishi Electric Co., Ltd. (manufactured in or after 1988), EG, SG series by Fuji Electric Co., Ltd. (manufactured in or after 1984).

■ Installation of Magnetic Contactor

Inverters can be used without a Magnetic Contactor (MC) installed at the power supply side. When the main circuit power supply is shut OFF in the sequence, a MC can be used instead of a MCCB. However, when a MC is switched OFF at the primary side, regenerative braking does not function and the motor coasts to a stop.

- The load can be operated/stopped by opening/closing the MC at the primary side. However, frequent switching may cause the Inverter to malfunction.
- When using a Braking Resistor Unit, use a sequencer to break power supply side on overload relay trip contact. If the Inverter malfunctions, the Braking Resistor Unit may be damaged.

■ Terminal Block Connection Sequence

Input power supply phases can be connected to any terminal regardless of the order of L1, L2 and L3 (R, S, and T) on the terminal block.

■ Installation of AC Reactor

When connecting an Inverter (200V/400V 15kW or less) to a large capacity power supply transformer (600k VA or more), or when switching a phase advancing capacitor, excessive peak current flows in the input power supply circuit, which may damage the converter section. In such cases, install a DC Reactor (optional) between Inverter \oplus 1 and \oplus 2 terminals or an AC Reactor (optional) on the input side. Installation of a reactor is effective for improvement of power factor on the power supply side.



■ **Installation of Surge Suppressor**

For inductive loads (magnetic contactors, magnetic relays, magnetic valves, solenoids, magnetic brakes, etc.) connected near the Inverter, use a surge suppressor simultaneously.

■ **Prohibition of Installation of Phase Advancing Capacitor**

If a Phase Advancing Capacitor or Surge Suppressor is connected in order to improve the power factor, it may become overheated and damaged by Inverter high harmonic components. Also, the Inverter may malfunction because of overcurrent.

3.2.2 Wiring Precautions for Main Circuit Output

■ **Connection of Terminal Block and Load**

Connect output Terminals T1, T2, and T3 (U, V, and W) to motor lead wires T1, T2, and T3 (U, V, and W). Verify that the motor rotates in the forward direction (CCW: counterclockwise when viewed from the motor load side) with the forward RUN command. If the motor rotation is incorrect, exchange any two of output Terminals T1, T2, and T3 (U, V, and W).

■ **Strict Prohibition of Connection of Input Power Supply to Output Terminals**

Never connect the input power supply to output Terminals T1, T2, and T3 (U, V, and W).

■ **Strict Prohibition of Short Circuiting or Grounding of Output Circuit**

Never touch the output circuit directly or put the output line in contact with the Inverter case. Otherwise, it may cause an electrical shock or grounding. In addition, never short-circuit the output line.

■ **Prohibition of Connection of Phase Advancing Capacitor or LC/RC Noise Filter**

Never connect a Phase Advancing Capacitor or LC/RC noise filter to the output circuit.

■ **Avoidance of Installation of Magnetic Starter**

Do not connect a Magnetic Starter or MC to the output circuit. If the load is connected while the Inverter is running, the Inverter overcurrent protective circuit operates because of inrush current.

■ **Installation of Thermal Overload Relay**

An electronic overload protective function is incorporated into the Inverter. However, connect a Thermal Overload Relay when driving several motors with one Inverter or when using a multi-pole motor. When using a Thermal Overload Relay, set Inverter constant n033 to 0 (motor overload protection selection: no protection). Additionally, for Thermal Overload Relay at 50Hz, set the same rated current value as that described on the motor nameplate, or at 60Hz 1.1 times larger than the rated current value described on the motor nameplate.

■ **Wiring Distance between Inverter and Motor**

If the total wiring distance between Inverter and motor is excessively long and the Inverter carrier frequency (main transistor switching frequency) is high, harmonic leakage current from the cable will adversely affect the Inverter and peripheral devices.

If the wiring distance between Inverter and motor is long, reduce the Inverter carrier frequency as described below. Carrier frequency can be set by constant n050.

Table 2 Wiring Distance between Inverter and Motor

Wiring Distance between Inverter and Motor	Up to 164ft (50m)	Up to 328ft (100m)	More than 328ft (100m)
Carrier Frequency (Set value of constant n050)	15kHz or less (6)	10kHz or less (4)	5kHz or less (2)

3.2.3 Grounding

- Ground resistance
- 200 V class: 100 Ω or less, 400 V class: 10 Ω or less
- Never ground the Inverter in common with welding machines, motors, or other large-current electrical equipment. Run all the ground wires in a conduit separate from wires for large-current electrical equipment.



- Use the ground wires described in *Tables 5 or 6* and keep the length as short as possible.
- When using several Inverter units side by side, ground the units as shown in *Figure 10, (a) or (b)*. Do not loop the ground wires as shown in *(c)*.

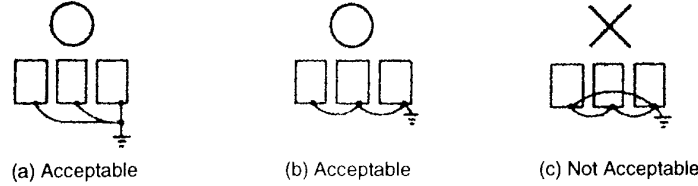

Figure 10 Grounding of Three Inverter Units

3.2.4 Functions of Main Circuit Terminals

The following table outlines the functions of the main circuit terminals. Wire according to each terminal function.

Table 3 200 V Class Terminal Functions

Models FP5/GP5	23P7 to 27P5	2011 to 2015	2018 to 2075
Max Applicable Motor Output	3.7 to 7.5 kW	11 to 15 kW	18.5 to 75 kW
L1 (R)	Main circuit input power supply		Main circuit input power supply
L2 (S)			
L3 (T)			
L11 (R1)			
L21 (S1)			
L31 (T1)	Inverter output		
T1 (U)			
T2 (V)			
T3 (W)			
B1	Braking Resistor Unit	—	
B2			
⊖	<ul style="list-style-type: none"> • DC Reactor (⊕1 – ⊕2) • DC bus terminals (⊕1 – ⊕2) 	<ul style="list-style-type: none"> • DC Reactor (⊕1 – ⊕2) • DC bus terminals (⊕1 – ⊕2) • Braking Unit (⊕3 – ⊖) 	—
⊕1			
⊕2			
⊕3	—		
⊕	Ground terminal (Ground resistance: 100 Ω or less)		



Chapter 3: Wiring

Table 4 400 V Class Terminal Functions

Models FP5/GP5	40P4 to 4015	4018 to 4045	4055 to 4160	4185 to 4300
Max Applicable Motor Output	0.4 to 15 kW	18.5 to 45 kW	55 to 160 kW	185 to 300 kW
L1 (R)	Main circuit input power supply	Main circuit input power supply		Main circuit input power supply
L2 (S)				
L3 (T)				
L11 (R1)	—	Main circuit input power supply		—
L21 (S1)				
L31 (T1)				
T1 (U)	Inverter output			
T2 (V)				
T3 (W)				
B1	Braking Resistor Unit	—		
B2				
⊖	<ul style="list-style-type: none"> • DC Reactor (⊕1 – ⊕2) • DC bus terminals (⊕1 – ⊖) 	—	• Braking Unit (⊕ 3 – ⊖)	
⊕ 1				
⊕ 2			—	
⊕ 3	—		• Braking Unit (⊕ 3 – ⊖)	
r (l 1)	—		Cooling fan power supply (Control power supply r (l 1) – s 200 (l 2 200): 200 to 230 VAC input r (l 1) – s 400 (l 2 400): 380 to 460 VAC input	
s 200 (l 2 200)				
s 400 (l 2 400)				
⊕	Ground terminal (Ground resistance: 10Ω or less)			



3.2.5 Main Circuit Configuration

200V Class

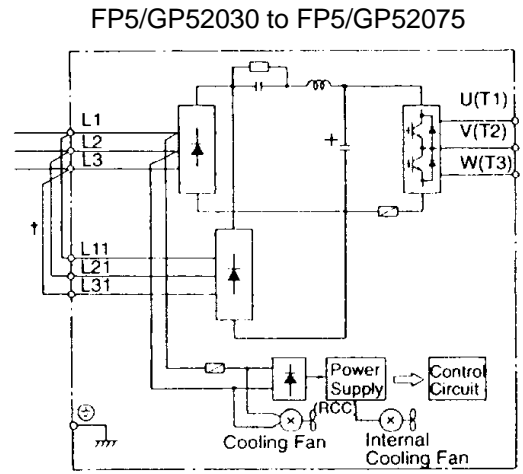
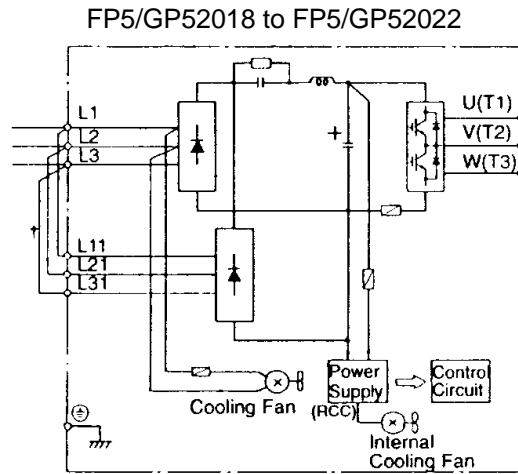
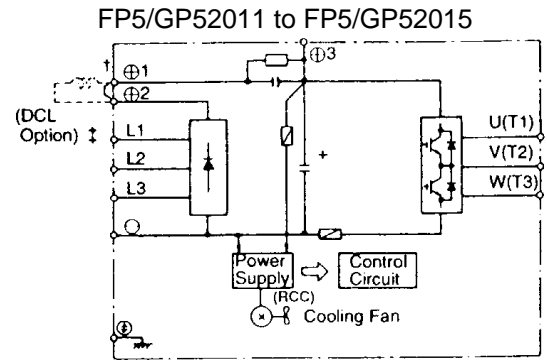
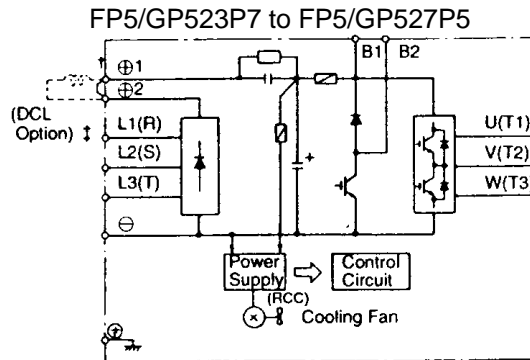

- † The wiring has been completed at the factory prior to shipping.
- ‡ When installing a DC Reactor (option) on models of 15kW or below, remove the short-circuit bar between ⊕ 1 and ⊕2 terminals and connect a DC Reactor with the terminals.

400V Class

FP5/GP540P4 to FP5/GP541P5

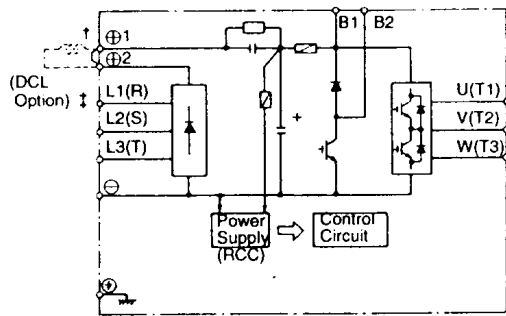

FP5/GP542P2 to FP5/GP54015

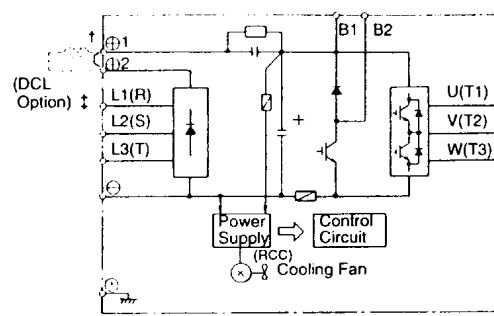

FP5/GP54018 to FP5/GP54045

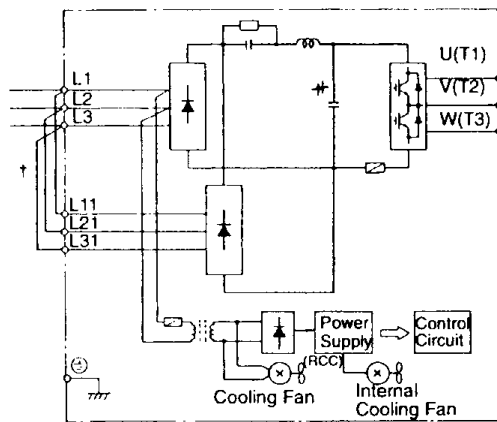

FP5/GP54055 to FP5/GP54160

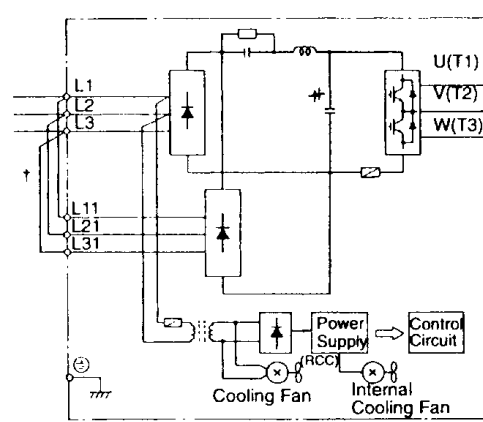

FP5/GP54185 to FP5/GP54300

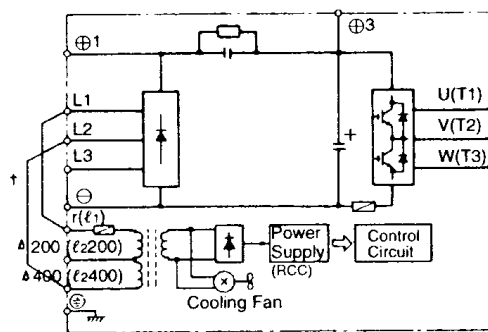

- † The wiring has been completed at the factory prior to shipping.
- ‡ When installing a DC Reactor (option) on models of 15kW or below, remove the short-circuit bar between ⊕ 1 and ⊕ 2 terminals and connect a DC Reactor with the terminals.



3.2.6 Parts Required for Wiring

Select wires or Closed-Loop Connectors to be used for wiring from *Tables 5, 6 and 7.*

Table 5 200 V Class Wire Size

Circuit	Model FP5/GP5	Terminal Symbol	Terminal Screw	Wire Size †		Wire Type
				AWG	mm ²	
Main	23P7	L1, L2, L3, (R, S, T) ⊖, ⊕ 1, ⊕ 2, B1, B2, T1, T2, T3 (U, V, W)	M4	10	5.5	Power cable: 600V vinyl sheathed wire or equivalent
		⊕				
	25P5	L1, L2, L3, (R, S, T) ⊖, ⊕ 1, ⊕ 2, B1, B2, T1, T2, T3 (U, V, W)	M5	8	8	
		⊕		10-8	5.5 – 8	
	27P5	L1, L2, L3, (R, S, T) ⊖, ⊕ 1, ⊕ 2, B1, B2, T1, T2, T3 (U, V, W)	M5	8	8	
		⊕		10-8	5.5 – 8	
	2011	L1, L2, L3, (R, S, T) ⊖, ⊕ 1, ⊕ 2, ⊕ 3, T1, T2, T3 (U, V, W)	M6	4	22	
		⊕		8	8	
	2015	L1, L2, L3, (R, S, T) ⊖, ⊕ 1, ⊕ 2, ⊕ 3, T1, T2, T3 (U, V, W)	M8	3	30	
		⊕	M6	8	8	
	2018	L1,L2, L3, (R, S, T) L11, L21, L31, (R1, S1, T1), T1, T2, (U, V, W)	M8	3	30	
		⊕		6	14	
	2022	L1,L2, L3, (R, S, T), L11, L21, L31, (R1, S1, T1), T1, T2, T3 (U, V, W)	M8	2	38	
		⊕		6	14	
	2030	L1,L2, L3, (R, S, T), L11, L21, L31, T1, T2, T3, (U, V, W)	M10	4/0	100	
		⊕	M8	4	22	
2037	L1,L2, L3, (R, S, T), L11, L21, L31, T1, T2, T3, (U, V, W)	M10	1/0 x 2P	60 × 2P		
	⊕	M8	4	22		
2045	L1,L2, L3, (R, S, T), L11, L21, L31, T1, T2, T3, (U, V, W)	M10	1/0 x 2P	60 × 2P		
	⊕	M8	4	22		
2055	L1,L2, L3, (R, S, T), L11, L21, L31, T1, T2, T3, (U, V, W)	M10	1/0 x 2P	60 × 2P		
	⊕	M8	3	30		
2075	L1,L2, L3, (R, S, T), L11, L21, L31, T1, T2, T3, (U, V, W)	M12	4/0 x 2P	100 × 2P		
	⊕	M8	1	50		
Control	Common to all models	S1, S2, S3, S4, S5, S6, SC, FV, FI, FS, FC, AM, AC, M1, M2, MA, MB, MC	—	20-16	Stranded 0.5 – 1.25 Solid 0.5 – 1.25	Twisted shielded wire
		G	M3.5	20-14	0.5 – 2	

† Where size is determined using 75°C temperature-rated copper wire.



Chapter 3: Wiring

Table 6 400 V Class Wire Size

Circuit	Model FP5/GP5	Terminal Symbol	Terminal Screw	Wire Size †		Wire Type
				AWG	mm ²	
Main	40P4	L1, L2, L3, (R, S, T), ⊖, ⊕ 1, ⊕ 2, B1, B2, T1, T2, T3 (U, V, W)	M4		2 – 5.5	Power cable: 600V vinyl sheathed wire or equivalent
		⊕				
	40P7	L1, L2, L3 (R, S, T), ⊖, ⊕ 1, ⊕ 2, B1, B2, T1, T2, T3 (U, V, W)	M4		2 – 5.5	
		⊕				
	41P5	L1, L2, L3, (R, S, T), ⊖, ⊕ 1, ⊕ 2, B1, B2, T1, T2, T3 (U, V, W)	M4		2 – 5.5	
		⊕				
	42P2	L1, L2, L3 (R, S, T), ⊖, ⊕ 1, ⊕ 2, B1, B2, T1, T2, T3 (U, V, W)	M4		2 – 5.5	
		⊕				
	43P7	L1, L2, L3 (R, S, T), ⊖, ⊕ 1, ⊕ 2, B1, B2, T1, T2, T3 (U, V, W)	M4	14-10	2 – 5.5	
		⊕		12-10	3.5 – 5.5	
	44P0	L1, L2, L3 (R, S, T), ⊖, ⊕ 1, ⊕ 2, B1, B2, T1, T2, T3 (U, V, W)	M4		2 – 5.5	
		⊕				
	45P5	L1, L2, L3 (R, S, T), ⊖, ⊕ 1, ⊕ 2, B1, B2, T1, T2, T3 (U, V, W)	M4	12-10	3.5 – 5.5	
		⊕				
	47P5	L1, L2, L3 (R, S, T), ⊖, ⊕ 1, ⊕ 2, B1, B2, T1, T2, T3 (U, V, W)	M5	8-6	5.5	
		⊕				
4011	L1, L2, L3, (R, S, T), ⊖, ⊕ 1, ⊕ 2, B1, B2, T1, T2, T3 (U, V, W)	M5	8-6	8 – 14		
	⊕	M6	8	8		
4015	L1, L2, L3 (R, S, T), ⊖, ⊕ 1, ⊕ 2, B1, B2, T1, T2, T3 (U, V, W)	M5	8-6	8 – 14		
	⊕	M6	8	8		
4018	L1, L2, L3 (R, S, T), L11, L21, L31 (R1, S1, T11), T1, T2, T3 (U, V, W)	M6	6	14		
	⊕	M8	8	8		
4022	L1, L2, L3 (R, S, T), L11, L21, L31 (R1, S1, T11), T1, T2, T3 (U, V, W)	M6	4	22		
	⊕	M8	8	8		
4030	L1, L2, L3 (R, S, T), L11, L21, L31 (R1, S1, T11), T1, T2, T3 (U, V, W)	M8	4	22		
	⊕		8	8		

† Where size is determined using 75°C temperature-rated copper wire.



Table 6 400 V Class Wire Size (Continued)

Circuit	Model FP5/GP5	Terminal Symbol	Terminal Screw	Wire Size †		Wire Type
				AWG	mm ²	
Main	4037	L1, L2, L3 (R, S, T), L11, L21, L31 (R1, S1, T11), T1, T2, T3 (U, V, W)	M8	3	30	Power cable: 600V vinyl sheathed wire or equivalent
		⊕		6	14	
	4045	L1, L2, L3 (R, S, T), L11, L21, L31 (R1, S1, T11), T1, T2, T3 (U, V, W)	M8	1	50	
		⊕		6	14	
	4055	L1, L2, L3 (R, S, T), L11, L21, L31 (R1, S1, T11), T1, T2, T3 (U, V, W)	M10	4/0	100	
		⊕	M8	4	22	
	4075	L1, L2, L3 (R, S, T), L11, L21, L31 (R1, S1, T11), T1, T2, T3 (U, V, W)	M10	1/0 x 2P	60 x 2P	
		⊕	M8	4	22	
	4110	L1, L2, L3 (R, S, T), L11, L21, L31 (R1, S1, T11), T1, T2, T3 (U, V, W)	M10	1/0 x 2P	60 x 2P	
		⊕	M8	3	30	
	4160	L1, L2, L3 (R, S, T), L11, L21, L31 (R1, S1, T11), T1, T2, T3 (U, V, W)	M12	4/0 x 2P	100 x 2P	
		⊕	M8	1	50	
	4185	L1, L2, L3 (R, S, T), ⊖, ⊕ 1, ⊕ 3, T1, T2, T3 (U, V, W)	M16	650MCM x 2P	325 x 2P	
		⊕	M8	1	50	
		r (I ₁), S 200 (I ₂ 200), S 400 (I ₂ 400)	M4	20-10	0.5 – 5.5	
	4220	L1, L2, L3 (R, S, T), ⊖, ⊕ 1, ⊕ 3, T1, T2, T3 (U, V, W)	M16	650MCM x 2P	325 x 2P	
⊕		M8	1/0	60		
r (I ₁), S 200 (I ₂ 200), S 400 (I ₂ 400)		M4	20-10	0.5 – 5.5		
4300	L1, L2, L3 (R, S, T), ⊖, ⊕ 1, ⊕ 3, T1, T2, T3 (U, V, W)	M16	650MCM x 2P	325 x 2P		
	⊕	M8	1/0	60		
	r (I ₁), S 200 (I ₂ 200), S 400 (I ₂ 400)	M4	20-10	0.5 – 5.5		
Control	Common to all models	S1, S2, S3, S4, S5, S6, SC, FV, FI, FS, FC, AM, AC, M1, M2, MA, MB, MC	—	20-16	Stranded 0.5 – 1.25 Solid 0.5 – 1.25	Twisted shielded wire
		G	M3.5	20-14	0.5 – 2	

† Where size is determined using 75°C temperature-rated copper wire.



Chapter 3: Wiring

Table 7 Closed-Loop Connectors

AWG Size	Wire Size mm ²	Terminal Screw	Closed-Loop Connectors
20	0.5	M3.5	1.25 – 3.5
		M4	1.25 – 4
18	0.75	M3.5	1.25 – 3.5
		M4	1.25 – 4
16	1.25	M3.5	1.25 – 3.5
		M4	1.25 – 4
14	2	M3.5	2 – 3.5
		M4	2 – 4
		M5	2 – 5
		M6	2 – 6
12-10	3.5 / 5.5	M8	2 – 8
		M4	5.5 – 4
		M5	5.5 – 5
		M6	5.5 – 6
8	8	M8	5.5 – 8
		M5	8 – 5
		M6	8 – 6
6	14	M8	8 – 8
		M6	14 – 6
4	22	M8	14 – 8
		M6	14 – 6
3-2	30 / 38	M8	14 - 8
1-1/0	50 / 60	M8	38 – 8
		M10	60 – 8
3/0	80	M10	60 – 10
4/0	100		80 – 10
4/0	100	M12	100 – 10
300MCM	150		100 – 12
400MCM	200		150 – 12
650MCM	325	M12 x 2	200 – 12
		M16	325 – 12
			325 – 16

NOTE: When determining wire size, consider voltage drop. Select a wire size so that voltage drop will be less than 2% of the normal rated voltage. Voltage drop is calculated by the following equation:

$$\text{Phase-to-phase voltage drop (V)} = \sqrt{3} \times \text{wire resistance } (\Omega/\text{km}) \times \text{wiring distance (m)} \times \text{current (A)} \times 10^{-3}$$



3.3 Wiring the Control Circuit

The following table outlines the functions of the control circuit terminals. Wire according to each terminal function.

3.3.1 Functions of Control Circuit Terminals

Table 8 Control Circuit Terminals

Classification	Terminal	Signal Function	Description		Signal Level
Sequence Input Signal	S1	Forward run/stop	Forward run when closed, stop when open		Photo-coupler insulation Input: + 24 VDC 8 mA
	S2	Reverse run/stop	Reverse run when closed, stop when open	Multi-function contact inputs (n035 to n039)	
	S3	External fault input	Fault when closed, normal state when open		
	S4	Fault reset input	Reset when closed		
	S5	Multi-step speed reference 1	Effective when closed		
	S6	Multi-step speed reference 2	Effective when closed		
	SC	Sequence control input common terminal	—		
Analog Input Signal	FS	+ 15 V Power supply output	For analog command + 15 V power supply		+ 15 V (Allowable current 20 mA maximum)
	FV	Frequency reference input (voltage)	0 to + 10 V/100%	n042 = 0 : FV effective	0 to + 10 V (20 kΩ)
	FI	Frequency reference input (current)	4 to 20 mA/100%	n042 = 1 : FI effective	4 to 20mA (250Ω)
	FC	Common terminal for control circuit	0 V		—
	G	Connection to shield sheath of signal lead	—		—
Sequence Output Signal	M1	During running (NO contact)	Closed when running	Multi-function contact output (n041)	Dry contact Contact capacity: 250 VAC 1 A or less 30 VDC 1 A or less
	M2				
	MA	Fault contact output (NO/NC contact)	Fault when closed between Terminals MA and MC. Fault when open between Terminals MB and MC.	Multi-function contact output (n040)	Dry contact Contact capacity: 250 VAC 1 A or less 30 VDC 1 A or less
	MB				
	MC				
Analog Output Signal	AM	Frequency meter output	0 to + 10 V/100% frequency	Multi-function analog monitor 1 (n048)	0 to + 10 V 2 mA or less
	AC	Common			

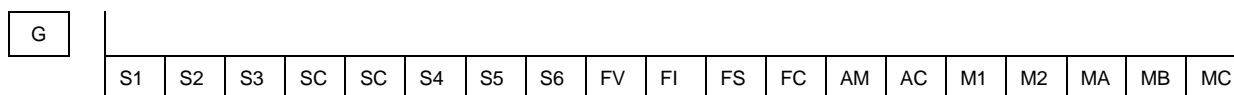
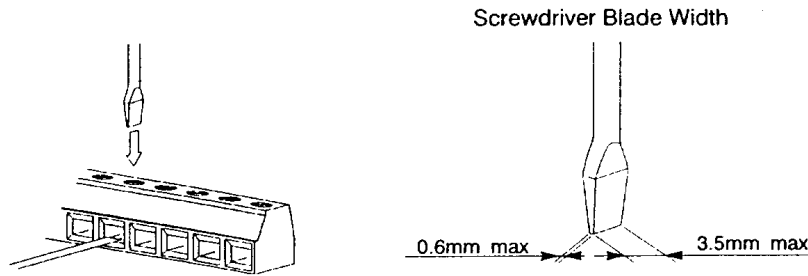

Figure 11 Control Circuit Terminal Arrangement

3.3.2 Wiring the Control Circuit Terminals



Insert the wire into the lower part of the terminal block and connect it tightly with a screwdriver. Wire sheath strip length must be 7 mm (approximately ¼ inch).

3.3.3 Precautions on Control Circuit Wiring

- Separate control circuit wires from main circuit wires and other power cables to prevent erroneous operation caused by noise interference.

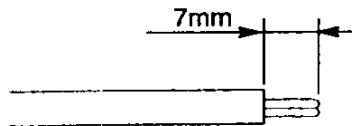

- Use twisted shielded or twisted-pair shielded wire for the control circuit line and connect the shielded sheath to the Inverter Terminal G. See Figure 12.

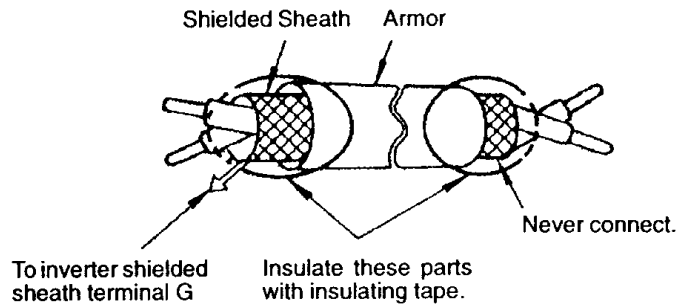

Figure 12 Shielded Wire Termination

3.4 Wiring Inspection

After completing installation and wiring, check for the following items. Never use control circuit megger check.

- Wiring is proper.
- Wire clippings or screws are not left in the unit.
- Screws are securely tightened.
- Bare wire in the terminal does not contact other terminals.



4

Operation

This chapter describes the basic operation procedures of the FP5/GP5.

4.1	Operation Mode Selection	25
4.2	Test Run Checkpoints	26
4.3	Setting the Line Voltage Using Jumper (For 400V Class 18.5kW and Above)	26
4.4	Test Run.....	27
4.4.1	Digital Operator Display at Power-Up	27
4.4.2	Operation Check Points.....	2/
4.4.3	Example of Basic Operation.....	28

**WARNING**

- Only turn ON the input power supply after replacing the front cover. Do not remove the cover while current is flowing. Failure to observe this can result in an electrical shock.
- When the retry function (n057) is selected, do not approach the Inverter or the load, since it may restart suddenly after being stopped. (Construct machine system, so as to assure safety for personnel, even if the Inverter should restart.) Failure to observe this can result in personal injury.
- Since the stop button can be disabled by a function setting, install a separate emergency stop switch. Failure to observe this can result in personal injury.

**CAUTION**

- Never touch the heatsink or discharging resistor since the temperature is very high. Failure to observe this can result in harmful burns to the body.
- Since it is easy to change operation speed from low to high speed, verify the safe working range of the motor and machine before operation. Failure to observe this can result in personal injury and machine damage.
- Install a holding brake separately if necessary. Failure to observe this caution can result in personal injury.
- Do not change signals during operation. The machine or the Inverter may be damaged.
- All the constants of the Inverter have been preset at the factory. Do not change the settings unnecessarily. The Inverter may be damaged. For supply voltage, follow *Paragraph 4.3 of Chapter 4*.



4.1 Operation Mode Selection

The FP5/GP5 has two operation modes, LOCAL and REMOTE, as described in *Table 9*. These two modes can be selected by the Digital Operator LOCAL/REMOTE key only while the operation is stopped. The selected Operation mode can be verified by observing the Digital Operator SEQ and REF LED's as shown below. The Operation mode is set to REMOTE (run by control circuit Terminals FV and FI frequency reference and RUN command from a control circuit terminal) prior to shipment. Multi-function contact inputs from control circuit Terminals S3 to S6 are enabled in both Operation modes LOCAL/REMOTE.

- LOCAL : Both frequency reference and RUN command are set by the Digital Operator. SEQ and REF LED's go OFF.
- REMOTE : Master frequency reference and RUN command can be selected as described in *Table 9*.

Table 9 Reference Selection in REMOTE Mode (n002: Operation Method Selection)

Setting	Operation Method Selection	Reference Selection		
		SEQ LED		REF LED
0	Operation by RUN command from Digital Operator	OFF	Master frequency reference from Digital Operator	OFF
1	Operation by RUN command from control circuit terminal	ON	Master frequency reference from Digital Operator	OFF
2	Operation by RUN command from Digital Operator	OFF	Master frequency reference from control circuit Terminals FV and FI	ON
3	Operation by RUN command from control circuit terminal	ON	Master frequency reference from control circuit Terminals FV and FI	ON
4	Operation by RUN command from Digital Operator	OFF	Master frequency reference set by serial communication	ON
5	Operation by RUN command from control circuit terminal	ON	Master frequency reference set by serial communication	ON
6	Operation by RUN command from serial communication	ON	Master frequency reference set by serial communication	ON
7	Operation by RUN command from serial communication	ON	Master frequency reference from Digital Operator	OFF
8	Operation by RUN command from serial communication	ON	Master frequency reference from control circuit Terminals FV and FI	ON

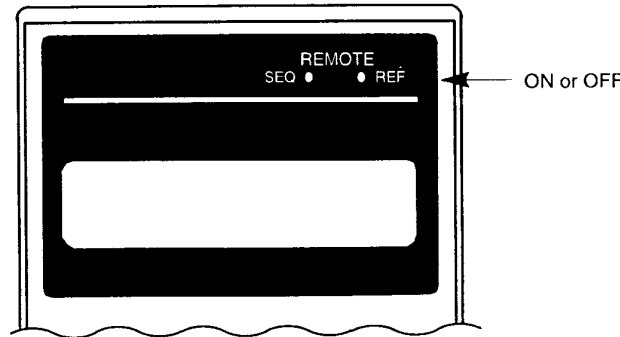

4.2 Test Run Checkpoints

To assure safety, prior to initial operation, disconnect the machine coupling so that the motor is isolated from the machine. If initial operation must be performed while the motor is still coupled to the machine, use great care to avoid potentially hazardous conditions. Check the following items before a test run.

- Wiring and terminal connections are correct.
- No short-circuit caused by wire clippings.
- Screw-type terminals are securely tightened.
- Motor is securely mounted
- All items are correctly earthed (grounded).

4.3 Setting the Line Voltage Using Jumper (For 400V Class 18.5kW and Above)

Set the line voltage jumper according to the main circuit power supply. (See *Figure 13.*) Insert the jumper at the appropriate location corresponding to the input line voltage. It has been preset at the factory to 440V.

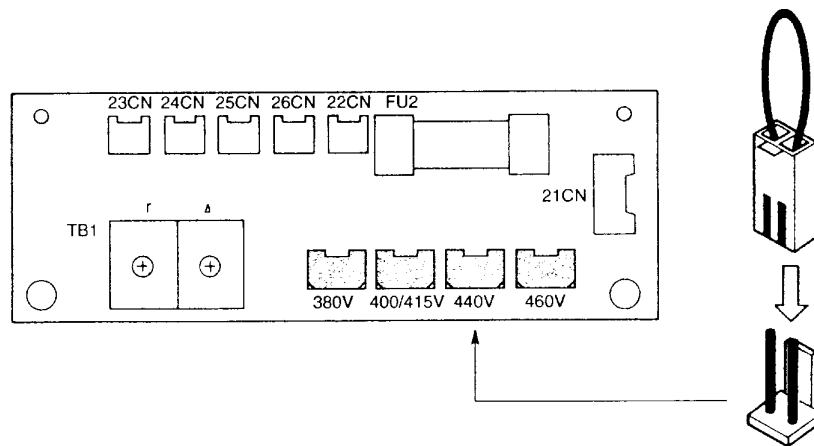

Figure 13 Line Voltage Jumper (For 400V Class 18.5kW to 45kW)



4.4 Test Run

4.4.1 Digital Operator Display at Power-up

When the system is ready for operation, turn ON the power supply. Verify that the Inverter powers up properly. If any problems are found, turn OFF the power supply immediately. The Digital Operator display illuminates as shown below when turning the power supply ON.

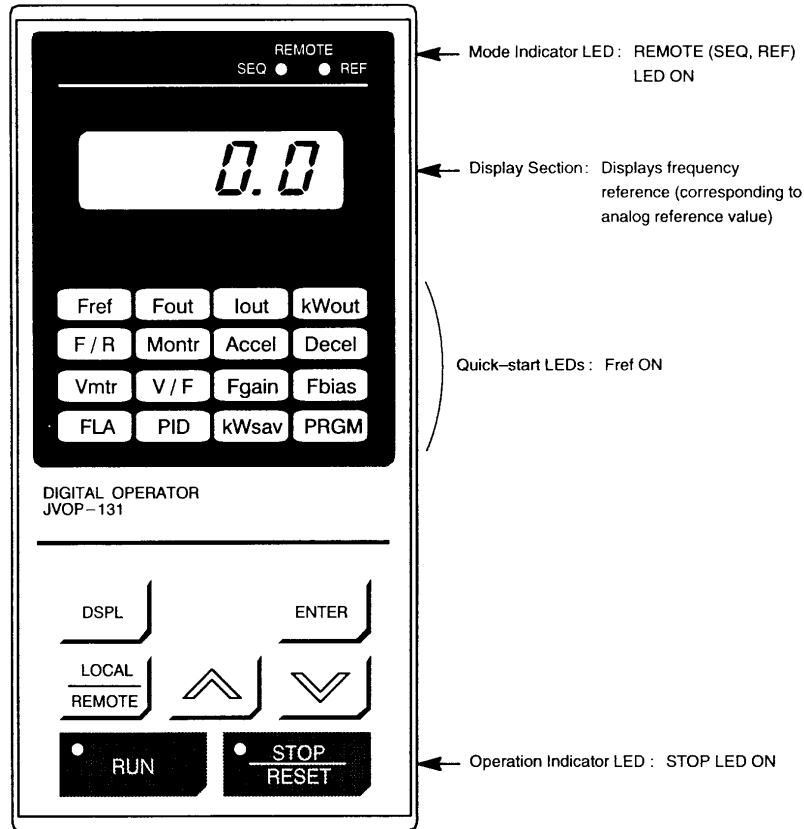

Figure 14 Digital Operator Display at Power-Up

4.4.2 Operation Check Points

Check the following items during operation.

- Motor rotates smoothly.
- Motor rotates in the correct direction.
- Motor does not have abnormal vibration or noise.
- Acceleration and deceleration are smooth.
- Current matches the load flow.
- Status indicator LED's and Digital Operator display are correct.

4.4.3 Example of Basic Operation.

■ Operation by Digital Operator

The diagram below shows a typical operation pattern using the Digital Operator.

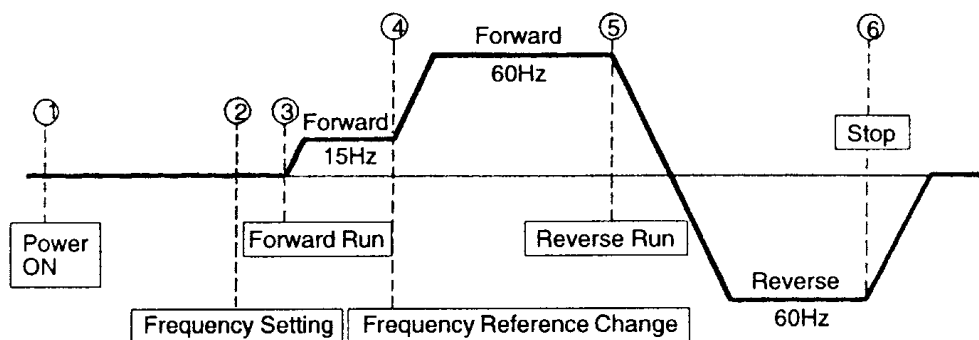

Figure 15 Operation Sequence by Digital Operator

Table 10 Typical Operation by Digital Operator

Description	Key Sequence	Digital Operator Display	LED Display
① Power ON <ul style="list-style-type: none"> • Display frequency reference value. Operation Condition Setting <ul style="list-style-type: none"> • Select LOCAL mode. 	<div style="border: 1px solid black; padding: 2px; text-align: center;">LOCAL REMOTE</div>	<div style="border: 1px solid black; padding: 5px; text-align: center;">0.0</div> REMOTE LED (SEQ. REF) OFF	<div style="border: 1px solid black; padding: 2px; text-align: center;">Fref</div>
② Frequency Setting <ul style="list-style-type: none"> • Change reference value. <ul style="list-style-type: none"> • Write-in set value. <ul style="list-style-type: none"> • Select output frequency monitor display. 	Change the value by pressing <div style="display: flex; justify-content: space-around; margin-top: 5px;"> <div style="border: 1px solid black; padding: 2px;">▲</div> <div style="border: 1px solid black; padding: 2px;">▼</div> </div> <div style="border: 1px solid black; padding: 2px; text-align: center; margin-top: 5px;">ENTER</div> <div style="border: 1px solid black; padding: 2px; text-align: center; margin-top: 5px;">DSPL</div>	<div style="border: 1px solid black; padding: 5px; text-align: center;">15.0</div> <div style="border: 1px solid black; padding: 5px; text-align: center; margin-top: 5px;">15.0</div> <div style="border: 1px solid black; padding: 5px; text-align: center; margin-top: 5px;">0.0</div>	<div style="border: 1px solid black; padding: 2px; text-align: center;">Fref</div> <div style="border: 1px solid black; padding: 2px; text-align: center; margin-top: 5px;">Fref</div> <div style="border: 1px solid black; padding: 2px; text-align: center; margin-top: 5px;">Fout</div>
③ Forward Run <ul style="list-style-type: none"> • Forward run (15 Hz) 	<div style="border: 1px solid black; padding: 2px; text-align: center; margin-top: 5px;">○ RUN</div>	<div style="border: 1px solid black; padding: 5px; text-align: center; margin-top: 5px;">15.0</div> RUN LED ON <div style="border: 1px solid black; padding: 2px; text-align: center; margin-top: 5px;">○ RUN</div>	<div style="border: 1px solid black; padding: 2px; text-align: center; margin-top: 5px;">Fout</div> <div style="border: 1px solid black; padding: 5px; text-align: center; margin-top: 5px;"> </div>



Table 10 Typical Operation by Digital Operator (continued)

<p>④ Frequency Reference Value Change (15 Hz to 60 Hz)</p> <ul style="list-style-type: none"> Select frequency reference value display. Change set value. Write-in set value. Select output frequency monitor display. <p>⑤ Reverse Run</p> <ul style="list-style-type: none"> Select reverse run. Write-in set value. 	<p>DSPL Press 7 times</p> <p>Change the value by pressing</p> <p>↑ ↓</p> <p>ENTER</p> <p>DSPL</p> <p>DSPL Press 3 times</p> <p>Switch to "rev" by pressing</p> <p>↑ ↓</p> <p>ENTER</p>	<p>15.0</p> <p>60.0</p> <p>60.0</p> <p>60.0</p> <p>for</p> <p>reu</p> <p>reu</p>	<p>Fref</p> <p>Fref</p> <p>Fref</p> <p>Fref</p> <p>F/R</p> <p>F/R</p> <p>F/R</p> <p>(Grid icon)</p>
<ul style="list-style-type: none"> Select output frequency monitor display. <p>⑥ Stop</p> <ul style="list-style-type: none"> Decelerates to a stop. 	<p>DSPL Press 5 times</p> <p>STOP RESET</p>	<p>60.0</p> <p>0.0</p> <p>RUN LED OFF STOP LED ON</p>	<p>Fout</p> <p>Fout</p>

■ Operation by Control Circuit Terminal Signal

The diagram below shows a typical operation pattern using the control circuit terminal signals.

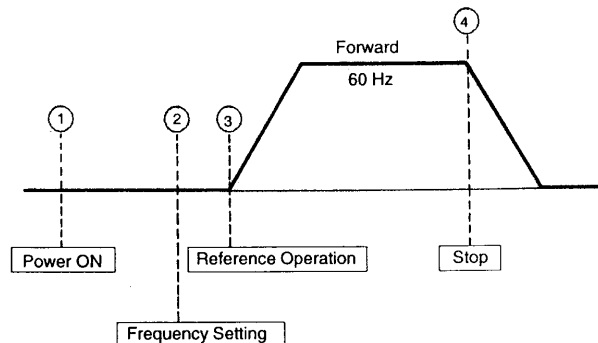







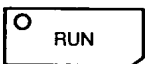

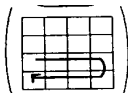



Figure 16 Operation Sequence by Control Circuit Terminal Signal



Chapter 4: Operation

Table 11 Typical Operation by Control Circuit Terminal Signal

Description	Key Sequence	Digital Operator Display	LED Display
① Power ON <ul style="list-style-type: none"> Display frequency reference value. REMOTE mode is preset at the factory 		 REMOTE LED (SEQ, REF) ON	
② Frequency Setting <ul style="list-style-type: none"> Input frequency reference voltage (current) by control circuit Terminal FV or FI and verify the input value by the Digital Operator. 		 For reference voltage 10V	
Output Frequency Display <ul style="list-style-type: none"> Select output frequency monitor display. 			
③ Forward Run <ul style="list-style-type: none"> Close between control circuit Terminals SI and SC to perform forward run. 		 RUN LED ON 	 
④ Stop <ul style="list-style-type: none"> Open between control circuit Terminals SI and SC to stop operation. 		 STOP LED ON (RUN LED blinking during deceleration)	



5

Simple Data Setting

This chapter describes simple data setting.

5.1	Digital Operator Key Description.....	32
5.2	LED Description	32

5.1 Digital Operator Key Description

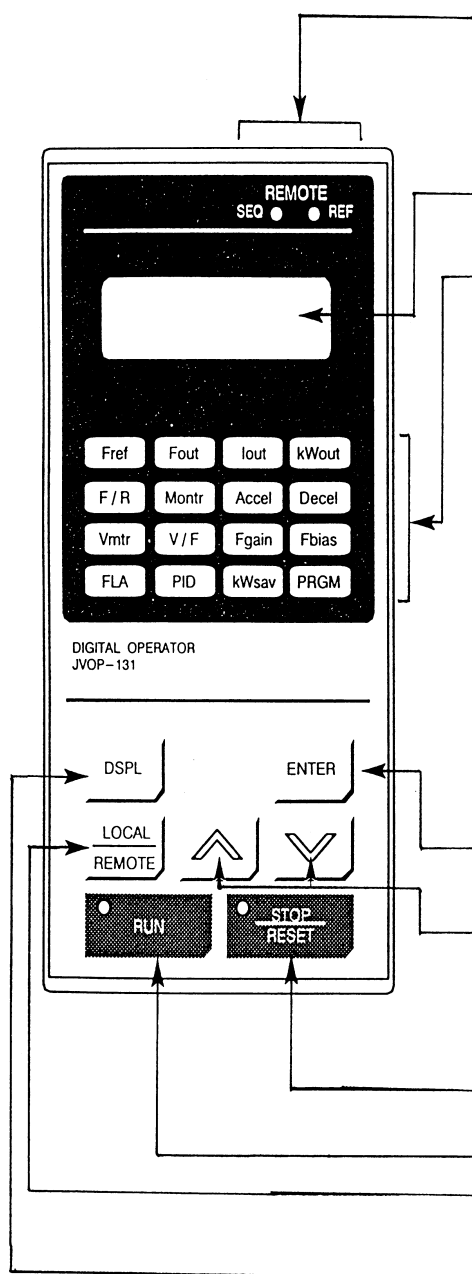

Mode Indicator LED's (Remote Mode)

Lights when selecting Input mode from the control circuit terminal or serial communication.

SEQ: Lights when selecting RUN command from control circuit terminal or serial communication.

REF: Lights when selecting frequency reference from control circuit Terminals FV and FI or serial communication.

Display

Displays set values of each function or monitoring values such as frequency and output current. (4 Digits)

Quick-Start LED's

LED	Description	Set/Read During Run
Fref	Frequency reference setting/monitoring	Enable
Fout	Output frequency monitor	Enable
Iout	Output current monitor	Enable
kWout	Output power monitor	Enable
F/R	FWD/REV RUN command selection	Enable
Montr	Monitor selection	Enable
Accel	Acceleration time	Enable
Decel	Deceleration time	Enable
Vmtr	Motor rated voltage	Disable
V/F	V/f pattern selection	Disable
Fgain	Frequency reference gain	Disable
Fbias	Frequency reference bias	Disable
FLA	Motor rated current	Disable
PID	PID selection	Disable
kWsav	Energy Saving selection	Disable
PRGM	Constant number/data	Disable

Enter Key

Displays each constant set value. By pressing this key again, the set value is written in.

Number Change Keys

Changes set values or constant numbers.

^ : Increment key

v : Decrement key

Operation Command Keys

Operation command keys operate the Inverter.

*STOP/RESET : Red LED lights by pressing STOP.
(Resets operation at faults. Reset is disabled while a RUN command is ON.)

RUN : Red LED lights by pressing RUN.

Operation Mode Selection Key

The Operation mode is alternated between REMOTE and LOCAL (Digital Operator).

Display Selection Key

Selects the contents of Quick-Start LED's. (See Page 33)

Figure 17 Digital Operator Key Description

5.2 LED Description

By using the Quick-Start LED's on the Digital Operator, simple operation of the Inverter is possible. Each Quick-Start LED is selected each time DSPL key is pressed. Following is a table describing Quick-Start LED selection.

(Example of model FP5/GP5)



NOTES:



Programming Features

This chapter describes programming features.

6.1	Constant Set-Up and Initialization	36
6.1.1	Constant Selection/Initialization (n001)	36
6.2	V/f Pattern Setting	36
6.2.1	Preset V/f Pattern	37
6.2.2	Custom V/f Pattern	38
6.3	Setting Operation Conditions	38
6.3.1	Reverse Run Prohibit (n006).....	38
6.3.2	Multi-Step Speed Selection	38
6.3.3	Operation at Low Speed.....	39
6.3.4	Adjusting Frequency Setting Signal.....	40
6.3.5	Adjusting Frequency Upper and Lower Limits.....	41
6.3.6	Using Two Accel/Decel Times	41
6.3.7	Automatic Restart after Momentary Power Loss (n051)	42
6.3.8	Soft-Start Characteristics (n023).....	42
6.3.9	Torque Detection	43
6.3.10	Frequency Detection (n073).....	44
6.3.11	Jump Frequencies (n058 to n060)	44
6.3.12	Continuing Operation by Automatic Fault Reset (n056).....	45
6.3.13	Operating Coasting Motor without Trip	45
6.3.14	Using Frequency Meter of Ammeter (n048)	46
6.3.15	Calibrating Frequency Meter of Ammeter (n049)	46
6.3.16	Reducing Motor Noise or Leakage Current (n050)	47
6.4	Selecting Stopping Method	48
6.4.1	Selecting Stopping Method (n004).....	48
6.4.2	Coast to Stop with Timer 1 (n004=2)	49
6.4.3	Applying DC Injection Braking Current (n064).....	49
6.5	Building Interface Circuits with External Devices	50
6.5.1	Using Sequence Input Signals (n035 to n039).....	50
6.5.2	Using Analog Input Signals (n042 to n045)	53
6.5.3	Using Output Signals (n040, n041).....	55
6.6	Setting Operation Conditions	56
6.6.1	Torque Compensation Gain (n067)	56
6.7	Motor Protection	57
6.7.1	Motor Overload Detection	57
6.8	PID Control	58
6.8.1	Intended Value Setting	58
6.8.2	Detected Value Setting.....	58
6.9	Energy Saving Control	59
6.9.1	Energy Saving Gain K2 (n096)	59
6.9.2	Energy Saving Tuning	59
6.10	MEMOBUS Control	60
6.10.1	Communication Specifications	60
6.10.2	Data to be Sent/Received by Communication.....	60

6.1 Constant Set-up and Initialization

6.1.1. Constant Selection/Initialization (n001)

The following table describes the data which can be set or read when n001 is selected.

Setting	Constant that can be set	Constant that can be read
0 (Constant write disable)	n001	n001 to n108
1 (Factory setting)	n001 to n034	n001 to n108
2	n001 to n049	n001 to n108
3	n001 to n108	n001 to n108
4, 5	Not used (disabled)	
8	Initialize: 2-wire sequence	
9	Initialize: 3-wire sequence*	

* Refer to Page 50.

6.2 V/f Pattern Setting

V/f pattern can be set by constant n010.

Set value 0 to E: Preset V/f pattern can be selected.

F : Custom V/f pattern can be set.



6.2.1. Preset V/f Pattern

The following shows the preset V/f patterns. (The voltages are for 200V class. For 400V class, the value is twice that of 200V class.)

Table 13 Preset V/f Pattern (n010 = 0 to E)

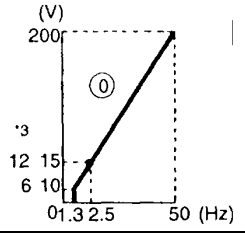
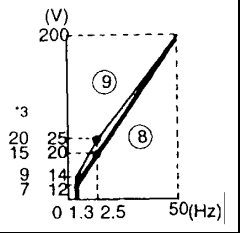
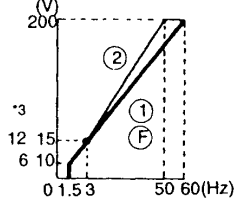
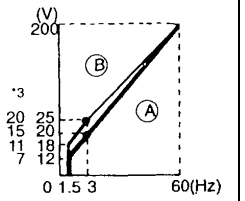
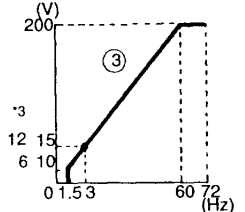
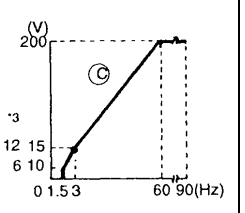
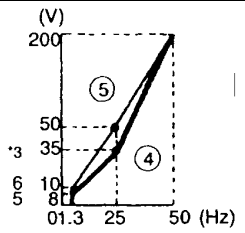
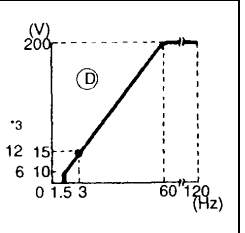
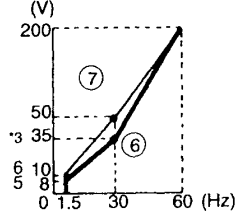
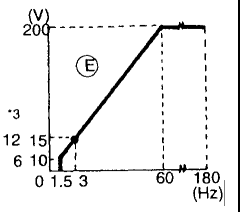
Specifications		n010	V/f Pattern *1	High Starting Torque *2	Specifications		n010	V/f Patterns *1			
General-Purpose	50 Hz	0			50 Hz	Low Starting Torque	8				
				High Starting Torque		9					
	60 Hz	60 Hz Saturation	1 F		60 Hz	Low Starting Torque	A				
	50 Hz Saturation	2	High Starting Torque			B					
	72 Hz	3			90 Hz	C					
Variable Torque Characteristics	50 Hz	Variable Torque 1		High Speed Operation	120 Hz	D					
		Variable Torque 2						5			
	60 Hz	Variable Torque 3	6						180 Hz	E	
		Variable Torque 4	7								

- * 1 Consider the following items as the conditions for selecting a V/f pattern. They must be suitable for:
 - The voltage and frequency characteristics of motor.
 - The maximum rotation speed of motor.
- * 2 Select high starting torque only in the following conditions. Normally, this selection is not required.
 - The wiring distance is long (150 meters (492 feet) and above).
 - Voltage drop at startup is large.
 - AC Reactor is inserted in the input or output of the Inverter.
 - A motor smaller than the nominal output of the Inverter is used.
- * 3 Voltages when the models of 200V, 55kW or above, or 400V, 55kW or above are selected.



Chapter 6: Programming Features

6.2.2. Custom V/f Pattern

Set each pattern when using a special motor (high-speed motor, etc.) or when requiring special torque adjustment of machine.

Make sure to satisfy the following conditions for setting of constants n012 to n018.

$$n017 \leq n015 < n014 \leq n012$$

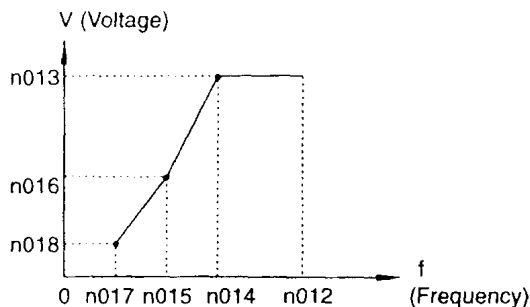

Figure 18 Custom V/f Pattern Setting

Constant No.	Name	Unit	Setting Range	Factory Setting
n012	Maximum output frequency	0.1 Hz	50.0 – 400.0 Hz	60.0 Hz
n013	Maximum voltage	0.1 V	0.1 – 255.0 V *	200.0 V *
n014	Maximum voltage output frequency (base frequency)	0.1 Hz	0.2 – 400.0 Hz	60.0 Hz
n015	Middle output frequency	0.1 Hz	0.1 –399.9 Hz	3.0 Hz
n016	Middle output frequency voltage	0.1 V	0.1 – 255.0 V *	15.0 V *
n017	Minimum output frequency	0.1 Hz	0.1 – 10.0 Hz	1.5 Hz
n018	Minimum output frequency voltage	0.1 V	0.1 – 50.0 V *	10.0 V *

* For 400 V class, the value is twice that of 200 V class.

Increasing the voltage of the V/f pattern increases motor torque, but an excessive increase may cause the following:

- Inverter malfunction because of motor overexcitation.
- Motor overheat or excessive vibration.

Increase voltage gradually while verifying the motor current.

6.3 Setting Operation Conditions

6.3.1. Reverse Run Prohibit (n006)

“Reverse run disabled” setting does not accept a reverse RUN command from the control circuit terminal or Digital Operator. This setting is used for applications where a reverse RUN command can cause problems.

Setting	Description
0	Reverse run enabled
1	Reverse run disabled

6.3.2. Multi-Step Selection

By combining frequency reference and input terminal function selections, up to four steps of speed can be set.

Four step speed change

- n002 = 1 (Operation mode selection)
- n025 = 30.0 Hz
- n026 = 40.0 Hz
- n027 = 50.0 Hz
- n028 = 60.0 Hz
- n038 = 9 (Multi-function contact input Terminal S5)
- n039 = 10 (Multi-function contact input Terminal S6)

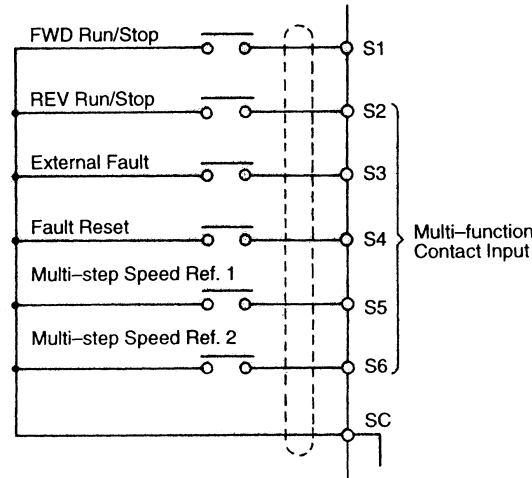

Figure 19 Multi-Speed Selection – Control Circuit Terminals



Figure 20 Multi-Step Speed Operation Timing Diagram

6.3.3. Operating at Low Speed

Set jog frequency reference selection in multi-function contact input terminals (S2 to S6). Then input a FWD or REV RUN command. Operation is enabled at the jog frequency set in n029. When multi-step speed references 1 or 2 are input simultaneously with the jog frequency reference, the jog frequency reference has priority.

Name	Constant No.	Setting
Jog frequency reference	n029	(Factory setting: 6.0 Hz)
Multi-function contact input selection (S2 to S6)	n035, n036, n037, n038, n039	Set to "11" (jog frequency selection) for any constant.

6.3.4. Adjusting Frequency Setting Signal

When the frequency reference is output by an analog input of control circuit Terminals FV and FI, the relationship between the analog input (voltage/current) and the frequency reference can be set.

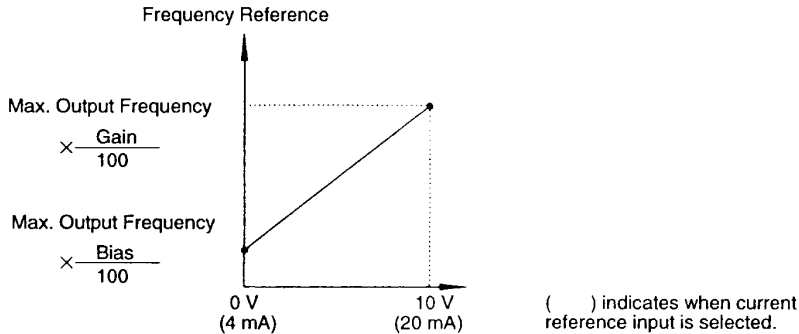

Figure 21 Frequency Signal Adjustment

▪ **Frequency Reference Gain (n046)**

The frequency reference at the analog input value of 10V (20mA) can be set in units of 1%. (n012 Maximum output frequency: 100%) Factory setting: 100%

▪ **Frequency Reference Bias (n047)**

The frequency reference at the analog input value of 0 V (4 mA) can be set in units of 1%. (n012 Maximum output frequency: 100%) Factory setting: 0%

Typical setting

- To operate the Inverter with frequency reference of 0% to 100% at 0 to 5V input.

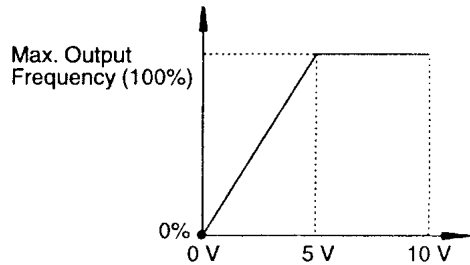

Gain: Constant n046 = 200

Bias: Constant n047 = 0

Figure 22 Frequency Signal Adjustment Example (0 to 5V Input)

- To operate the Inverter with frequency reference of 50% to 100% at 0 to 10V input.

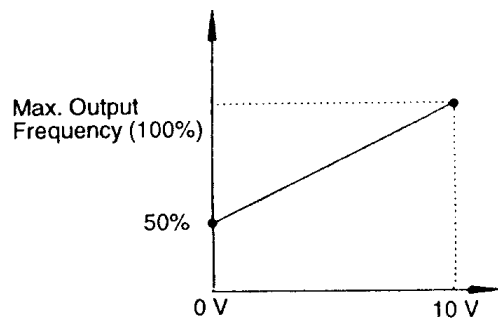

Gain: Constant n046 = 100

Bias: Constant n047 = 50

Figure 23 Frequency Signal Adjustment Example (0 to 10V Input)



6.3.5. Adjusting Frequency Upper and Lower Limits

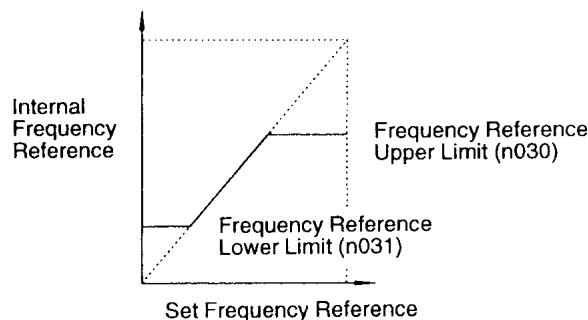

Figure 24 Setting Frequency Upper and Lower Limits

- **Frequency Reference Upper Limit (n030)**

Sets the upper limit of the frequency reference in units of 1%. (n012 Maximum output frequency: 100%) Factory setting: 100%

- **Frequency Reference Lower Limit (n031)**

Sets the lower limit of the frequency reference in units of 1%. (n012 Maximum output frequency: 100%)

When operating at a frequency reference of 0, operation is continued at the frequency reference lower limit. However, when the frequency lower limit is set to less than the minimum output frequency (n017), operation is not performed. Factory setting: 0%

6.3.6 Using Two Accel/Decel Times

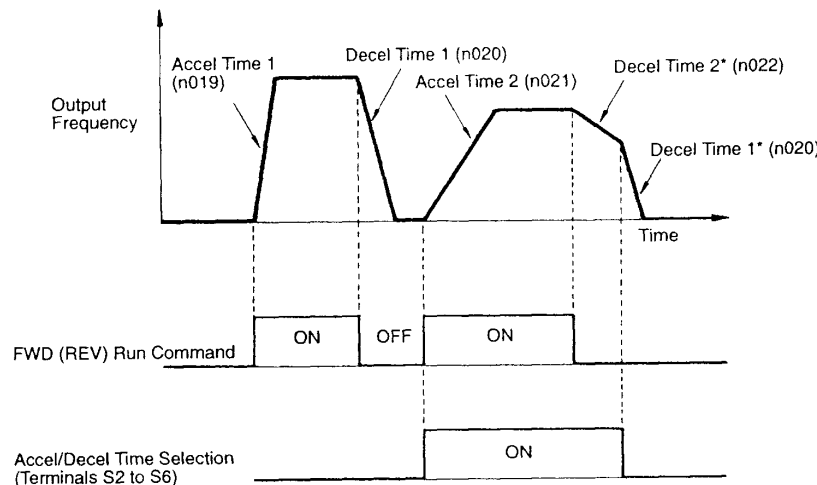

* When deceleration to stop is selected (n004 = 0)

Figure 25 Timing Diagram of Accel/Decel Time Adjustment

By setting multi-function contact input selection (n035, n036, n037, n038 or n039) to "12 (accel/decel time selection)", accel/decel time is selected by turning ON/OFF the accel/decel time selection (Terminal S2, S3, S4, S5 or S6).

At OFF : n019 (accel time 1), n020 (decel time 1)
 At ON : n021 (accel time 2), n022 (decel time 2)

Constant No.	Name	Unit	Setting Range	Factory Setting
n019	Accel time 1	0.1 s (1 s for 1000 s and above)	0.0 to 3600 s	10.0 s
n020	Decel time 1	0.1 s (1 s for 1000 s and above)	0.0 to 3600 s	10.0 s
n021	Accel time 2	0.1 s (1 s for 1000 s and above)	0.0 to 3600 s	10.0 s
n022	Decel time 2	0.1 s (1 s for 1000 s and above)	0.0 to 3600 s	10.0 s

- Accel time: Set the time needed for output frequency to reach 100% from 0%.
- Decel time: Set the time needed for output frequency to reach 0% from 100%.

6.3.7 Automatic Restart after Momentary Power Loss (n051)

When momentary power loss occurs, operation restarts automatically.

Setting	Description
0	Not provided (Factory setting)
1*	Continuous operation after power recovery within 2 seconds
2†	Continuous operation after power recovery within control logic time (No fault output. Restarts only while control power supply is ON.)

* Hold the Operation command to continue operation after recovery from a momentary power loss.

† When 2 is selected, operation restarts if power supply voltage reaches its normal level. No fault signal is output.

6.3.8. Soft-Start Characteristics (n023)

To prevent shock during machine starting and/or stopping, accel/decel can be performed in S-curve pattern.

Setting	S-curve Characteristic Time
0	S-curve not provided
1	0.2 s (Factory setting)
2	0.5 s
3	1.0 s

Note: S-curve characteristic time is the time from accel/decel rate 0 to a regular accel/decel rate determined by the set accel/decel time.

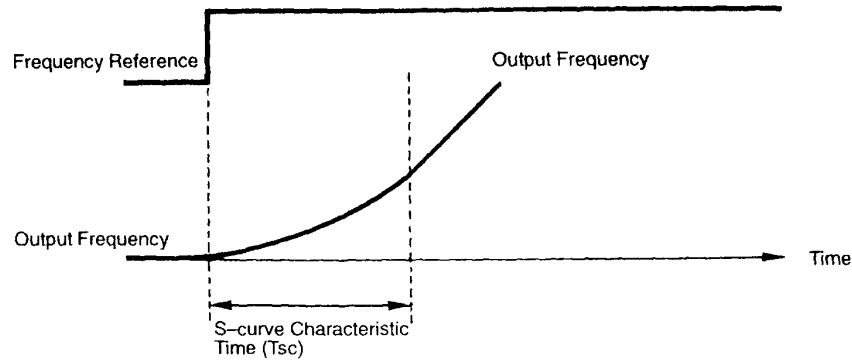

Figure 26 S-Curve Characteristic Timing

The following time chart shows switching from FWD/REV at deceleration to stop.

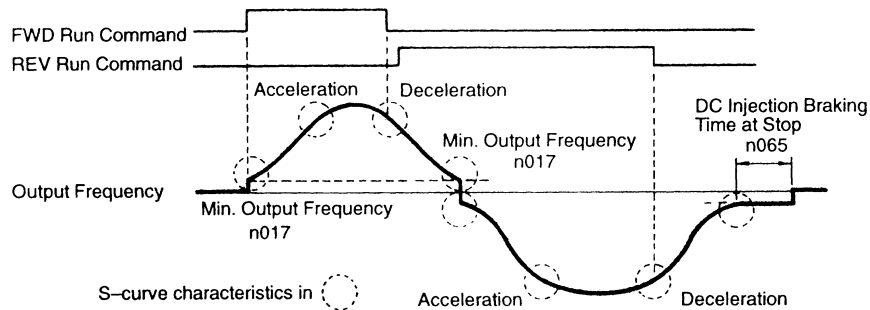

Figure 27 S-Curve Characteristic FWD/REV Operation



6.3.9 Torque Detection

If an excessive load is applied to the machine, output current increase can be detected by output alarm signals at multi-function contact output Terminals MA, MB and M1.

To output an overtorque detection signal, set multi-function contact output selection n040 or n041 to “overtorque detection” [Setting: 6 (NO contact) or 7 (NC contact)].

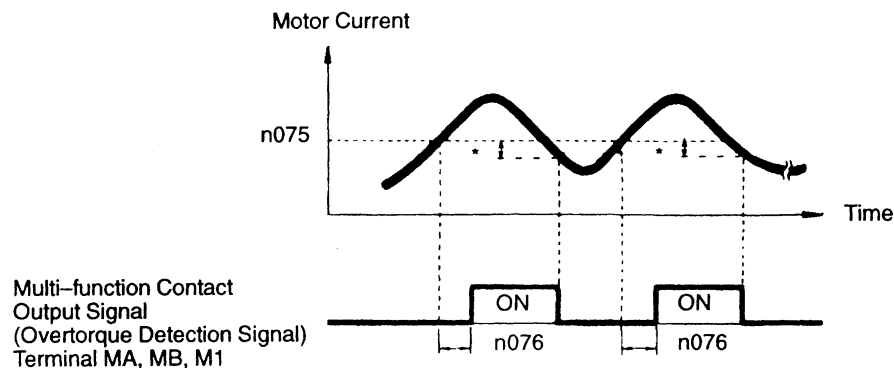

* Release width (hysteresis) during overtorque detection is 5% of the level of Inverter current.

Figure 28 Torque Characteristics

■ Overtorque Detection Function Selection (n074)

Setting	Description
0	Detection disabled (Factory setting).
1	Detected during constant-speed running, and operation continues after detection.
2	Detected during running, and operation continues after operation.
3	Detected during constant-speed running, and Inverter output is shut OFF during detection.
4	Detected during running, and Inverter output is shut OFF during detection.

- To detect overtorque during acceleration or deceleration, set to 2 or 4.
- To continue the operation after overtorque detection, set to 1 or 2. During detection, the Digital Operator displays “OL3” alarm (blinking).
- To halt the Inverter by a fault at overtorque detection, set to 3 or 4. At detection, the Digital Operator displays “OL3” fault (ON).

■ Overtorque Detection Level (n075)

Sets the overtorque detection current level in units of 1%. (Inverter rated current: 100%) Factory setting: 160%

■ Overtorque DetectionTime (n076)

If the time when motor current exceeds the overtorque detection level (n075) is longer than overtorque detection time (n076), the overtorque detection function operates. Factory setting: 0.1 seconds



Chapter 6: Programming Features

6.3.10 Frequency Detection (n073)

Effective when multi-function contact output selections n040 or n041 are set to frequency detection (Setting: 4 or 5). Frequency detection turns ON when output frequency is higher or lower than the frequency detection level (n073).

▪ **Frequency Detection (Output Frequency \leq Frequency Detection Level)**

(Set n040 or n041 to 4.)

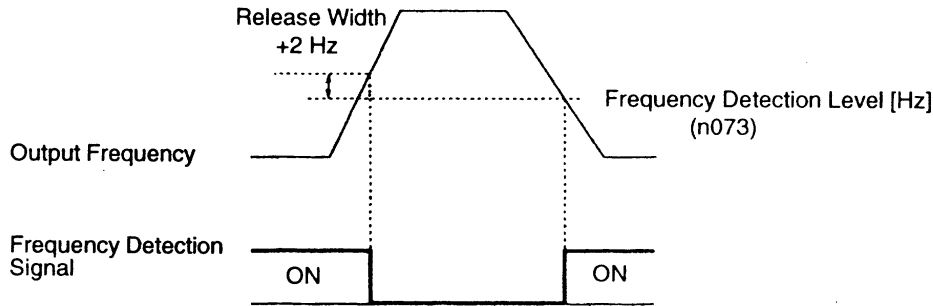

Figure 29 Frequency Detection Example
($F_{out} \leq$ Freq Detection Level)

▪ **Frequency Detection (Output Frequency \geq Frequency Detection Level)**

(Set n040 or n041 to 5.)

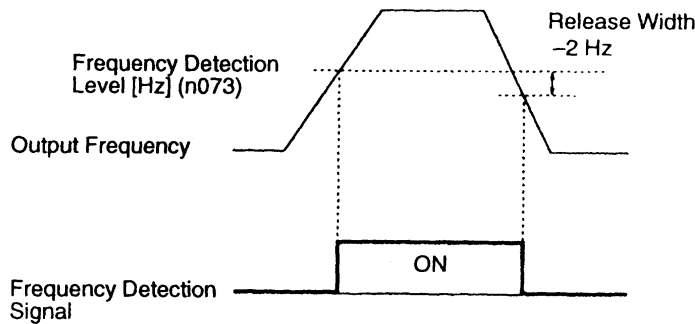

Figure 30 Frequency Detection Example
($F_{out} \geq$ Freq Detection Level)

6.3.11 Jump Frequencies (n058 to n060)

This function allows the prohibition or “jumping” of critical frequencies so that the motor can operate without resonance caused by machine systems. This function is also used for dead band control. Setting the value to 0.0Hz disables this function.

Set jump frequency 1 or 2 as follows:

$$n058 < n059 - n060$$

If this condition is not satisfied, the Inverter displays constant setting error OPE6.

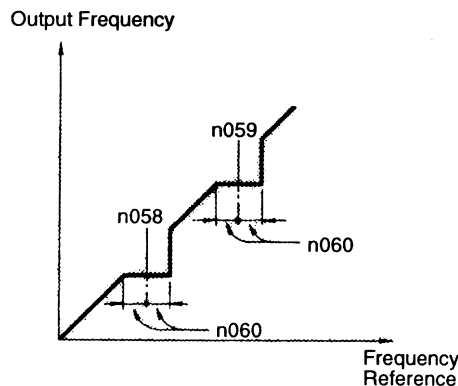

Figure 31 Jump Frequencies



6.3.12 Continuing Operation by Automatic Fault Reset (n056)

Sets the Inverter to restart and reset fault detection after a fault occurs. The number of self-diagnosis and retry attempts can be set in n056 up to 10. The Inverter will automatically restart after the following faults occur:

- OC (overcurrent)
- OV (overvoltage)
- UV1 (undervoltage PUV) (when n051 = 1 is selected)
- GF (ground fault)
- rr (regenerative transistor fault)

The number of retry attempts are cleared to 0 in the following cases:

- If no other fault occurs within 10 minutes after retry.
- When the fault reset signal is ON after the fault is detected.
- Power supply is turned OFF.

6.3.13 Operating Coasting Motor without Trip

To operate coasting motor without trip, use the Speed Search command or DC Injection Braking at start.

■ Speed Search Command

Restarts a coasting motor without stopping it. This function enables smooth switching between motor commercial power supply operation and Inverter operation.

Set multi-function contact input selection (constants n035 to n039) to 15 (Search command from maximum output frequency) or 16 (Search command from set frequency).

Build a sequence so that FWD or REV RUN command is input at the same time or after the Search command. If the RUN command is input before the Search command, the Search command becomes disabled.

Following is a time chart at Search command input.

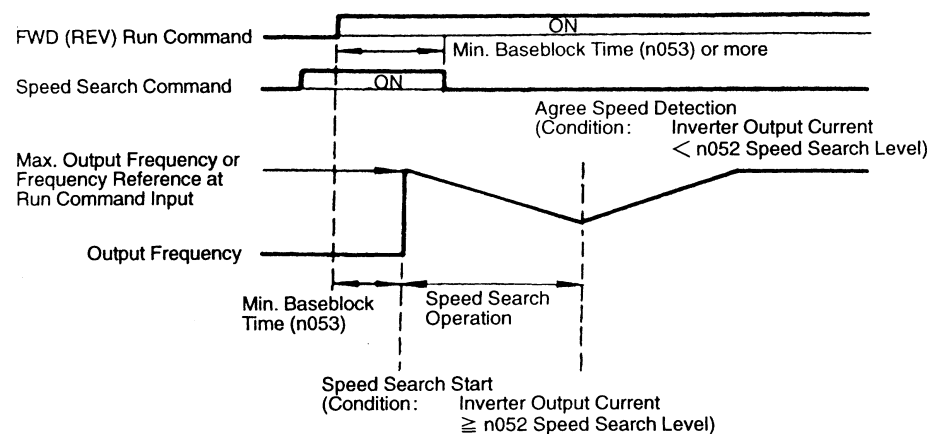

Figure 32 Search Command Input Timing Diagram

Chapter 6: Programming Features

■ **DC Injection Braking at Start (n064, n066)**

Restarts a coasting motor after stopping it. Set the DC Injection Braking time at start in constant n066 in units of 0.1 second. When constant n066 is set to 0, DC Injection Braking is not performed and acceleration starts from the minimum output frequency.

Set DC Injection Braking current in constant n064 in units of 1%. The Inverter rated current is 100%.

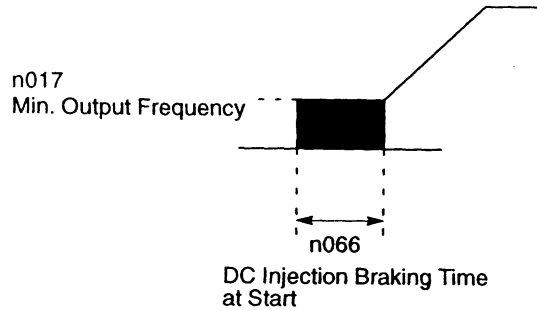

Figure 33 DC Injection Braking at Starting

6.3.14 Using Frequency Meter of Ammeter (n048)

Selects to output either output frequency or output current to analog output Terminals AM-AC for monitoring.

Setting	Analog Monitor Output Item
0	Output frequency (10 V/maximum frequency)
1	Output current (10 V/Inverter rated current)
2	Output power (10 V/Inverter rated voltage)
3	DC bus voltage [10 V/400 V (200 V class), 10 V/800 V (400 V class)]

6.3.15 Calibrating Frequency Meter of Ammeter (n049)

Used to adjust analog output again.

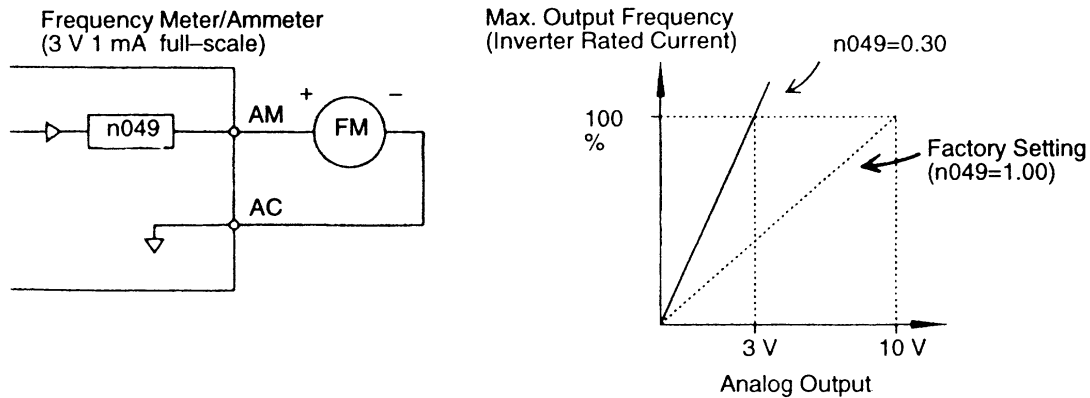

Set the analog output voltage at 100% of output frequency.

Figure 34 Frequency Meter/Ammeter Calibration

Frequency meter displays 0 to 60Hz at 0 to 3V.

$$10 \text{ V} \times \frac{\text{n049 Setting}}{1.00} = 3 \text{ V}$$

Output frequency becomes 100% at this value.



6.3.16 Reducing Motor Noise or Leakage Current (n050)

Sets Inverter output transistor switching frequency (carrier frequency).

Setting	Carrier Frequency (kHz)	Metallic Noise from Motor	Noise and Current Leakage
1	2.5	Higher ↑ ↓ Not audible	Smaller ↑ ↓ Larger
2	5.0		
3	8.0		
4	10.0		
5	12.5		
6	15.0		

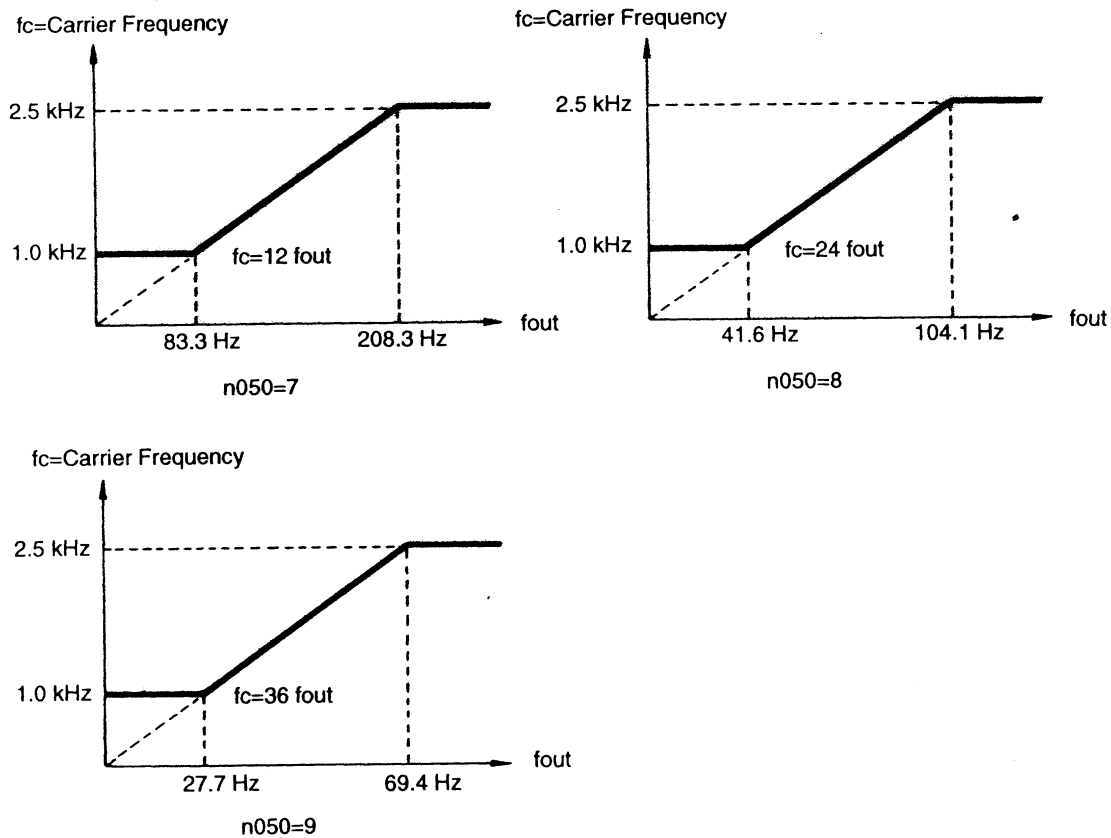

Figure 35 Custom Setting of Carrier Frequency Patterns

6.4 Selecting Stopping Method

6.4.1. Selecting Stopping Method (n004)

Selects the stopping method suitable for the application.

Setting	Description
0	Deceleration to stop (Factory setting)
1	Coast to stop
2	Coast to stop with timer 1
3	Coast to stop with timer 2

■ Deceleration to Stop (n004 = 0)

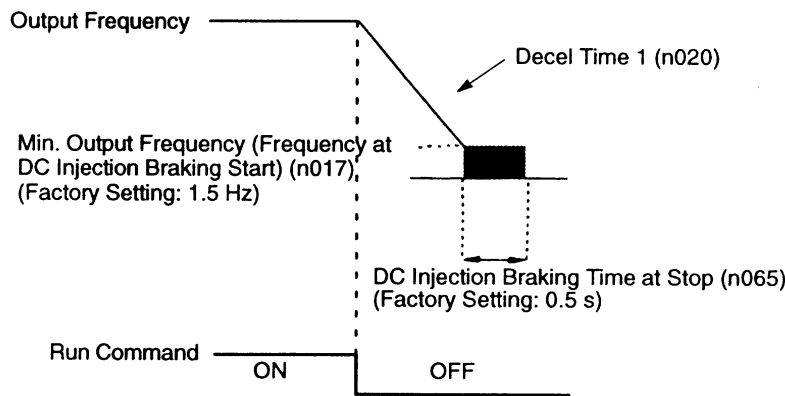

Figure 36 Stopping Method (Deceleration to Stop)

Upon removal of the FWD or REV RUN command, the motor decelerates at the deceleration rate determined by the time set to decel time 1 (n020), and DC Injection Braking is applied immediately before stop. If the decel time is short or the load inertia is large, an overvoltage (OV) fault may occur at deceleration. In this case, increase the decel time or install an optional Braking Resistor (can be equipped with GP5).

Braking torque : Without Braking Resistor : Approximately 20% torque of motor rating
 With Braking Resistor : Approximately 150% torque of motor rating

■ Coast to Stop (n004 = 1)

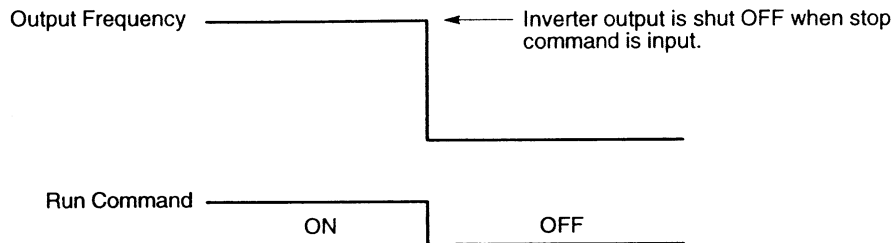

Figure 37 Stopping Method (Coast to Stop)

Upon removal of the FWD or REV RUN command, the motor starts coasting.



6.4.2. Coast to Stop with Timer

■ Coast to Stop with Timer 1 (n004 = 2)

Example of accel/decel time 1 selection

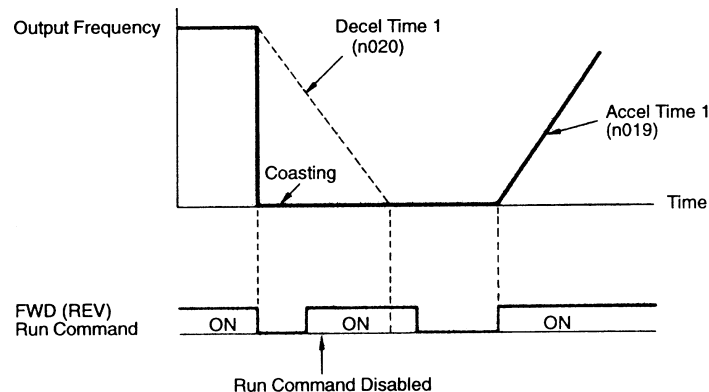

Figure 38 Example of Stopping Method
(Coast to Stop with Timer)

A RUN command is not accepted while the motor decelerates after a STOP command is given. However, if the time required for the motor to decelerate to a stop is shorter than the time set in constant n053 (minimum baseblock time), a RUN command is not accepted during the baseblock time.

■ Coast to Stop with Timer 2 (n004 = 3)

Example of accel/decel time 1 selection

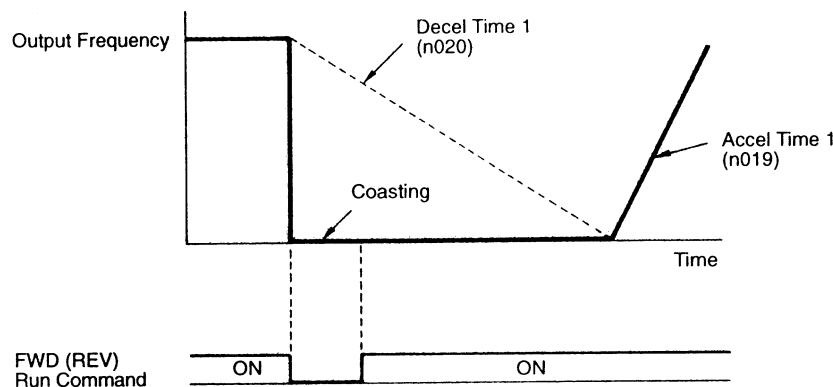

Figure 39 Example of Stopping Method
(Coast to Stop w/ Timer 2)

Operation is disabled while the motor decelerates after a STOP command is given. A RUN command is accepted, but operation does not start until the motor stops. However, if the deceleration time is shorter than the time set in n053 (minimum baseblock time), the Inverter does not operate during the baseblock time.

6.4.3. Applying DC Injection Braking

■ DC Injection Braking Current (N064)

Sets the DC Injection Braking current in units of 1%. (Inverter rated current: 100%)

■ DC Injection Braking Time at Stop (n065)

Sets the DC Injection Braking time at stopping in units of 0.1 second. When the setting is 0, DC Injection Braking is not performed, but Inverter output is shut OFF when DC Injection Braking starts.

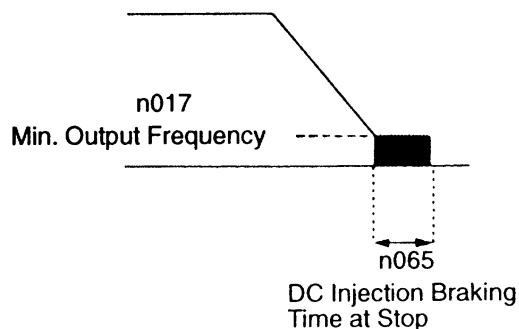

Figure 40 DC Injection Braking

When coast to stop is specified in stopping method selection (n004), DC Injection Braking at stop does not operate.

6.5 Building Interface Circuits with External Devices

6.5.1. Using Sequence Input Signals (n035 to n039)

Multi-function contact input Terminal S2 to S6 functions can be changed when necessary by setting constants n035 to n039, respectively. Neither of these parameters can receive a setting common with the other.

- Terminal S2 function: Set to n035
- Terminal S3 function: Set to n036
- Terminal S4 function: Set to n037
- Terminal S5 function: Set to n038
- Terminal S6 function: Set to n039

Table 14 Multi-Function Input Variables

Setting	Name	Description	Page
0	REV RUN command (2-wire sequence)	Only constant n035 can be set.	51
1	FWD/REV RUN command (3-wire sequence)	Only constant n035 can be set.	51
2	External fault (NO constant input)	Inverter stops at fault when external fault signal is input. Digital Operator displays EF□*.	—
3	External fault (NC contact input)		
4	Fault reset	Resets fault. Fault reset is disabled during RUN command input.	—
5	LOCAL/REMOTE selection	—	51
6	Serial communication/control circuit terminal selection	—	52
7	Fast stop	Decelerates to stop by decel time 2 (n022) when fast stop is input.	—
8	Master frequency reference input level selection	Master frequency reference input level (voltage input at open, current input at closed) can be selected.	—
9	Multi-step speed reference 1	—	38
10	Multi-step speed reference 2		
11	Jog frequency selection	—	39
12	Accel/decel time selection	—	41
13	External baseblock (NO contact input)	Coasting signal. Motor starts coasting when the signal is input. Digital Operator displays bb (blinking).	—
14	External baseblock (NC contact input)		
15	Search command from maximum frequency	Speed Search command signals.	45
16	Search command from set frequency		
17	Constant setting enable/disable	Permission or prohibition of constant setting from the Digital Operator or serial communication (setting disabled at closed, enabled at open) can be selected.	—
18	PID integral value reset	—	58
19	PID Control disable		
20	Timer function	—	52
21	OH3 (Inverter overheat alarm)	When this signal is input, the Digital Operator displays OH3 (blinking). Inverter continues operation.	—
22	Analog reference sample/hold	Analog frequency reference is sampled at closed and held at open.	52
25	UP/DOWN command	Only constant n039 can be set.	53
26	Loop test	Only constant n039 can be set.	53

*2 to 6 are displayed in □ corresponding to Terminals S2 to S6.

Factory settings: n035=0, n036=2, n037=4, n038=9, n039=10



■ **Terminal Function at 2-Wire Sequence Selection (Setting: 0)**

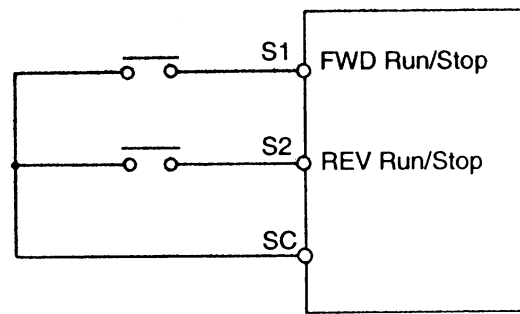

Figure 41 Terminal Function at 2-Wire Sequence Selection

■ **Terminal Function at 3-Wire Sequence Selection (Setting: 1)**

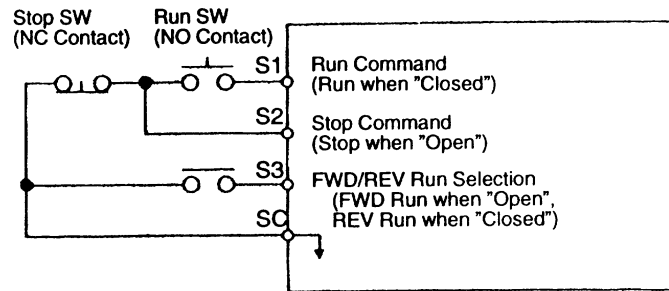

Figure 42 Terminal Function at 2-Wire Sequence Selection

■ **LOCAL/REMOTE Selection (Setting: 5)**

Selects operation reference by the Digital Operator or by the control circuit terminal. LOCAL/REMOTE selection is available only during stop.

Open : Run according to the setting of Operation mode selection (n022).

Closed : Run by frequency reference and RUN command from the Digital Operator.

(Example) Set n002 to 3.

Open : Run by frequency reference from control circuit Terminals FV, FI and RUN command from control circuit Terminals S1, S2.

Closed : Run by frequency reference and RUN command from the Digital Operator.

■ **Serial Communication/Control Circuit Terminal Selection (Setting: 6)**

Selects operation reference by serial communication or by the control circuit terminal. This selection is available only during stop.

Open : Run according to the setting of Operation mode selection (n022).

Closed : Run by frequency reference and RUN command from serial communication.

(Example) Set n002 to 3.

Open : Run by frequency reference from control circuit Terminals FV, FI and RUN command from control circuit Terminals S1, S2.

Closed : Run by frequency reference and RUN command from serial communication.

■ **Timer Function (Setting: 20)**

When the timer function input is longer than ON-delay timer (n077), the timer function output closes.

When the timer input is open for longer than OFF-delay timer (n078), the timer function output opens.

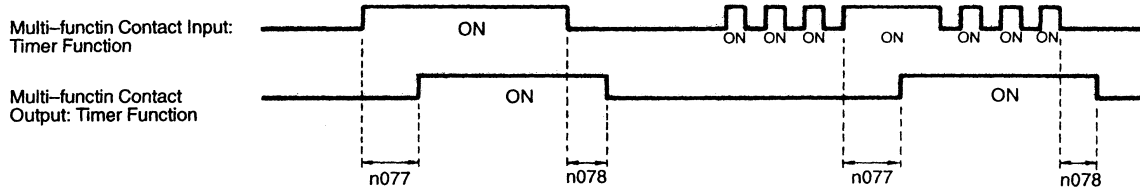
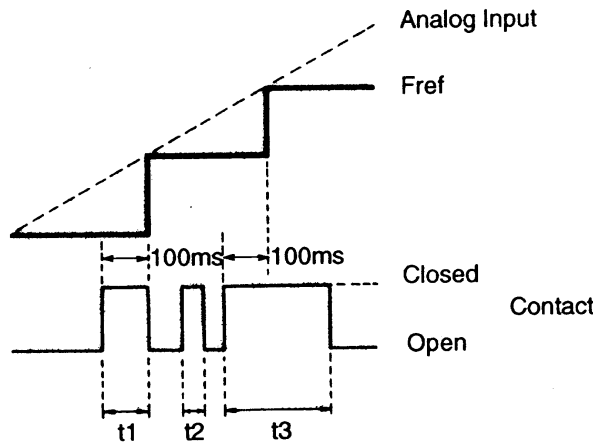

Figure 43 Timing Diagram of Timer Function

■ **Analog Reference Sample/Hold Selection (Setting: 22)**

If input terminal is closed for 100ms or more, the analog frequency reference is sampled; when it opens, the analog frequency reference is held.



Note: t1, t3 : Reference is held at 100ms or more.

t2 : Reference is not held at less than 100ms.

Figure 44 Sample of Hold Selection (Analog Reference)

■ **UP/DOWN Command (Setting: n039 = 25)**

With the FWD or REV RUN command entered, accel/decel is enabled by inputting the UP or DOWN signals to control circuit Terminals S5 and S6 without changing the frequency reference, so that operation can be performed at the desired speed.

When UP/DOWN commands are specified by n039, any function set to n038 becomes disabled; Terminal S5 becomes an input terminal for the UP command and Terminal S6 for the DOWN command.

Table 15 Timing Diagram of UP/DOWN Command Input

Control Circuit Terminal S5 (UP command)	Closed	Open	Open	Closed
Control Circuit Terminal S6 (DOWN command)	Open	Closed	Open	Closed
Operation Status	Accel	Decel	Hold	Hold



The following shows the time chart at UP/DOWN command input.

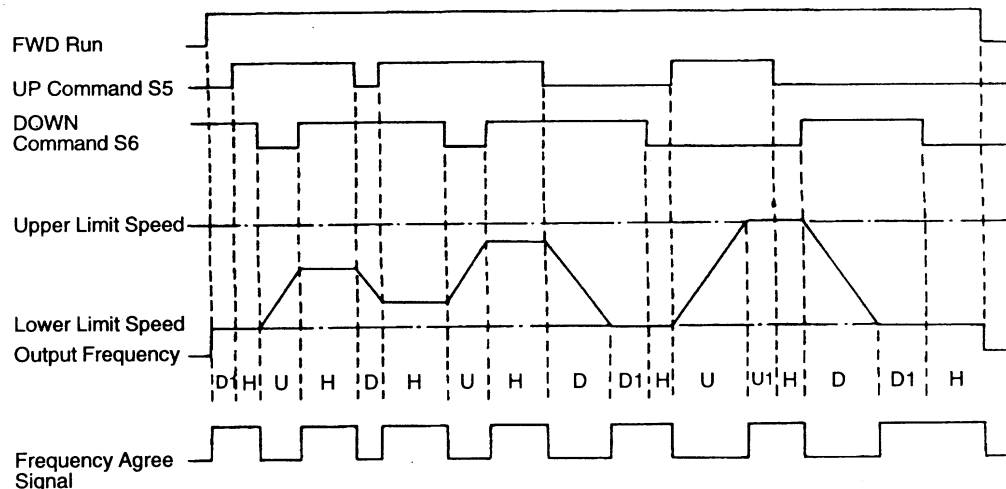

Figure 45 Timing Diagram of VP/Down Command Input

- U = UP (accelerating) status
- D = DOWN (decelerating) status
- H = HOLD (constant Speed) status
- U1 = UP status, clamping at upper limit speed
- D1 = DOWN status, clamping at lower limit speed

- NOTE:**
1. When UP/DOWN command is selected, the upper limit speed is set regardless of frequency reference. Upper limit speed = Maximum output frequency (n012) × Frequency reference upper limit (n030)/100
 2. Lower limit value is either frequency by Analog command from control circuit Terminals, FV, FI or frequency reference lower limit (n031) (whichever is larger).
 3. When the FWD or REV RUN command is input, operation starts at the lower limit speed without an UP/DOWN command.
 4. If the jog frequency selection command is input while running by the UP/DOWN command, the jog command has priority.

■ **Loop Test (Setting: 26)**

Checks operation in the serial I/F circuit. If a fault occurs, the Digital Operator displays CE.

Procedure

1. Set the multi-function contact input selection (n039) after turning ON the Inverter power supply, and then turn OFF the Inverter power supply.
2. Short-circuit Terminals S6 and SC, connector 2CN pins 1 and 2. (Do not short-circuit when connecting communication interface card SI-K2/P.)
3. Loop test is started by turning ON the Inverter power supply.

The Digital Operator displays the frequency reference after the loop test is completed satisfactorily.

6.5.2. Using Analog Input Signals (n042 to n045)

■ **Master Analog Input Selection (n042)**

To input the master frequency reference from the control circuit terminal, select voltage reference Terminal FV or current reference Terminal FI by setting constant n042.

Setting	Master Frequency Reference Terminal	Input Level
0	FV	0 to 10 V input
1	FI	4 to 20 mA input

■ Auxiliary Analog Input Selection (n043)

To change the control circuit Terminal FI input level, set constant n043.

Setting	FI Terminal Input Level
0	0 to 10 V input
1	4 to 20 mA input

NOTE: To set constant n043 to 0, cut jumper J1 on the Inverter control PC board.

■ Frequency Reference Retention (n044)

Effective when UP/DOWN or Sample/Hold commands are selected for multi-function contact inputs. To retain the held frequency reference at power OFF, set constant n044 to 0.

Setting	Description
0	Hold reference retained in frequency reference 1 (constant n025)
1	Not retained

■ Operation Method for Frequency Reference Loss Detection (n045)

Select operation in case the frequency reference from control circuit terminal decreases rapidly.

Setting	Description
0	No detection
1	Continue to run at 80% of Fmax.

(Operation when 1 is selected)

If frequency reference decreases by 90% within 400ms, operation is performed at 80% of the reference reached before decreasing.



6.5.3. Using Output Signals (n040, n041)

Multi-function contact output Terminals MA, MB and M1 functions can be changed when necessary by setting constants n040 and n041.

- Terminal MA and MB functions: Set to n040.
- Terminal M1 function: Set to n041.

Table 16 Multi-Function Output Variables

Setting	Name	Description	Page
0	Fault	Closed when Inverter fault occurs.	—
1	During running	Closed when either FWD or REV RUN command is input or when the Inverter outputs voltage.	—
2	Frequency agree	—	56
3	Desired frequency agree	—	56
4	Frequency detection 1	—	44
5	Frequency detection 2	—	44
6	Overtorque detection (NO contact)	—	43
7	Overtorque detection (NC contact)	—	43
8	During baseblock	Closed when Inverter output shuts OFF.	—
9	Operation mode	Closed when RUN command or frequency reference from Digital Operator is selected.	—
10	Inverter operation ready	Closed when no Inverter fault does not occur and the Inverter can be operated.	—
11	Timer function	—	52
12	Automatic restart	Closed during fault retry operation.	—
13	OL pre-alarm	Outputs an alarm before Inverter and motor overload protection are enabled. Pre-alarm level is 150% for 48 seconds for the Inverter and more than 80% of the overload protection time for the motor.	—
14	Frequency reference loss	Outputs a contact when detecting a rapid decrease in the frequency reference. A rapid decrease in the frequency reference means that the reference value is reduced more than 90% within 400ms when the reference is input to control circuit terminal.	—
15	Output from serial communication	Activates contact output independently from Inverter operation by a command from serial communications (MEMOBUS).	—
16	PID feedback loss	Detects a rapid decrease in feedback and outputs a contact when the PID Control mode is set. Detects when the feedback value decreases less than the detection level (n093) for longer than the feedback loss detection delay time (n094); the Inverter continues operation.	—
17	OH1 alarm	Closed during heatsink overtemperature (Digital Operator displays OH1" blinking).	—

Factory settings: n040=0, n041=1

▪ **Setting Example of Frequency Agree Signal (Setting: 2)**

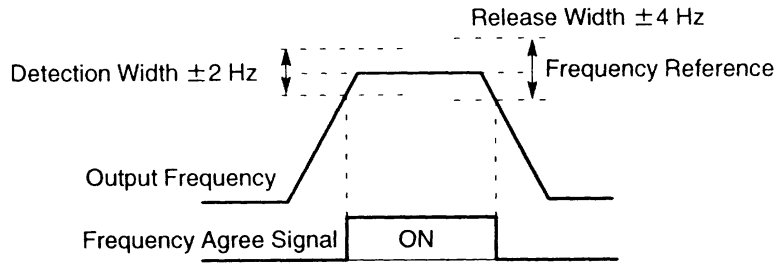

Figure 46 Example of Frequency Agree Signal

▪ **Setting Example of Desired Frequency Agree Signal (Setting: 3)**

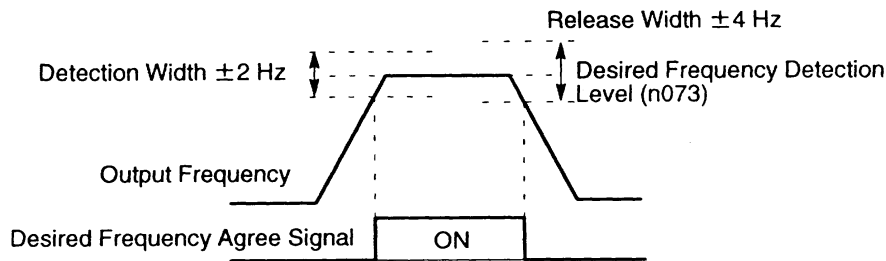

Figure 47 Example of Desired Frequency Agree Signal

6.6 Adjusting Motor Torque

6.6.1. Torque Compensation Gain (n067)

Motor torque requirement changes according to load conditions. Full-range automatic torque boost adjusts voltage of V/f pattern according to the requirement. The FP5/GP5 automatically adjusts the voltage during constant-speed operation as well as during acceleration. The required torque is calculated by the Inverter.

$$\text{Output voltage} \propto \text{Torque compensation gain (n067)} \times \text{Required torque}$$

- Operation

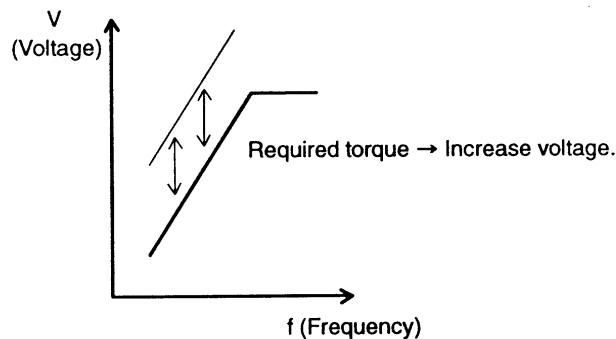

Figure 48 Torque Characteristics

Normally, no adjustment is necessary for torque compensation gain (n067 factory setting: 1.0). When the wiring distance between the Inverter and the motor is long, or when the motor generates vibration, change the torque compensation gain.

Increasing torque compensation gain increases motor torque, but an excessive increase may cause the following:

- Inverter malfunctions because of motor overexcitation.
- Motor overheat or excessive vibration.

Increase torque compensation gain gradually while verifying the motor current.



6.7 Motor Protection

6.7.1. Motor Overload Detection

The Inverter protects against motor overload with a built-in electronic Thermal Overload Relay.

- **Motor Rated Current (n032)**

Set to the rated current value shown on the motor nameplate.

- **Motor Overload Protection Selection (n033)**

Setting	Electronic Thermal Characteristics
0	No protection
1	Standard motor (time constant 8 minutes) (Factory setting)
2	Standard motor (time constant 5 minutes)
3	Inverter motor (time constant 8 minutes)
4	Inverter motor (time constant 5 minutes)

The electronic Thermal Overload Relay function monitors motor temperature, based on Inverter output current and time, to protect the motor from overheating. When electronic Thermal Overload Relay is enabled, an OL1 error occurs, shutting OFF the Inverter output and preventing excessive overheating in the motor.

When operating with one Inverter connected to one motor, an external Thermal Overload Relay is not needed. When operating several motors with one Inverter, install a Thermal Overload Relay on each motor. In this case, set constant n033 to 0.

- **Standard Motor and Inverter Motor**

Induction motors are classified as standard motors or Inverter motors, based on their cooling capabilities. Therefore, the motor overload function operates differently between these two motor types.

Table 17 Overload Curves

	Cooling Effect	Torque Characteristics	Electronic Thermal Overload
Standard Motor	Effective when operated at 50/60 Hz from commercial power supply.	<p>Operation Frequency (Hz) Base Frequency 60 Hz (V/f for 60 Hz, 220 V Input Voltage)</p> <p>For low speed operation, torque must be limited in order to stop motor temperature rise.</p>	OL1 error (motor overload protection) occurs when continuously operated at 50/60 Hz or less at 100% load.
Inverter Motor	Effective even when operated at low speed (approximately 6 Hz).	<p>Operation Frequency (Hz) Base Frequency 60 Hz (V/f for 60 Hz, 220 V Input Voltage)</p> <p>Use an inverter motor for continuous operation at low speed.</p>	Electronic Thermal Overload Relay protection not enabled even when continuously operated at 50/60 Hz or less at 100% load.

6.8 PID Control

To enable PID Control, set PID selection (n084) from 1 to 3.

Setting	Description
0	PID disabled
1	PID enabled (Deviation I D-controlled.)
2	PID with feed forward (Feedback value is D-controlled.)
3	PID with feed forward (Feedback is reversed characteristics.)

Then select the PID Control intended value or detected value settings as follows.

6.8.1. Intended Value Setting

For setting the intended value, control circuit Terminal FV voltage signal (0 to 10 V) or multi-step speed constants n025 to n029 can be used.

Control circuit Terminal FV voltage signal: Set Operation mode selection (n002) to 2 or 3.

Multi-step speed constants (n025 to n029): Set Operation mode selection (n002) to 0 or 1. (Combination of multi-step speed reference and jog frequency reference.)

6.8.2. Detected Value Setting

For setting the detected value, control circuit Terminal FI current signal (4 to 20mA) or voltage signal (0 to 10 V) can be used.

Control circuit Terminal FI current signal: Set auxiliary analog input selection (n043) to 1.

Control circuit Terminal FI voltage signal: Set auxiliary analog input selection (n043) to 0. (Cut jumper J1 on the control PC board.)

The following shows the block diagram of PID Control.

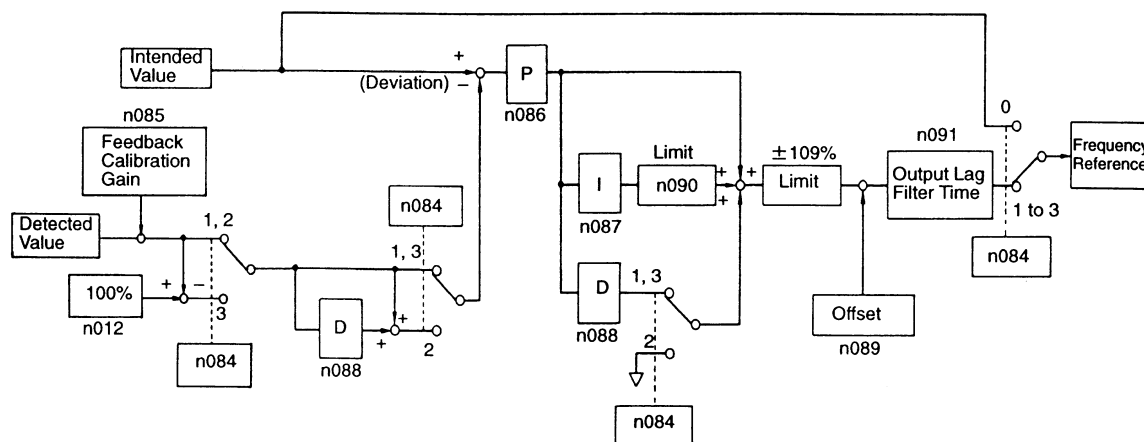

Figure 49 PID Control Block Diagram

- NOTE:**
- Value I is reset to 0 in the following cases:
 - When operation stops.
 - When the integral value reset signal is input by multi-function contact input selection. (Any of constants n035 to n039 are set to 18.)
 - The upper limit of value I can be set by constant n090. Increase the value of constant n090 to upgrade control capability by integration. If the control system vibrates and it cannot be stopped by adjusting the integral time or output lag filter time, etc., decrease the setting of constant n090.
 - PID Control can be canceled by a multi-function contact input signal. By setting any of constants n035 to n039 to 19, and by closing the contact during running, PID Control is disabled and the intended value signal itself is used as a frequency reference signal.



6.9 Energy Saving Control

To enable Energy Saving Control, set energy saving selection (n095) to 1.

Setting	Description
0	Energy saving is disabled
1	Energy saving is enabled

Since the constants used in the Energy Saving Control mode have been preset at the factory to the optimum values prior to shipment, it is not necessary to adjust them under normal operation. If your motor characteristics differ greatly from those of Saftronics standard motors, refer to the following description to change the constants.

6.9.1. Energy Saving Control Mode

■ Energy Saving Gain K2 (n096)

Use this energy saving gain when running in the Energy Saving Control mode to calculate the voltage at which motor efficiency will be greatest, and set it as the output voltage reference. This value is preset at the factory to the Saftronics standard motor value prior to shipment. As the energy saving gain increases, output voltage increases also.

■ Energy Saving Voltage Lower Limit (n097, n098)

Sets the output voltage lower limit. If the voltage reference value calculated in the Energy Saving Control mode is smaller than the specified lower limit, this lower limit value is output as the voltage reference value. The lower limit value is set in order to prevent stalling at light loads. Set voltage limits at 6Hz and 60Hz; a value obtained by linear interpolation should be set to any limit values other than at 6Hz or 60Hz. Setting is made as a percentage of motor rated voltage.

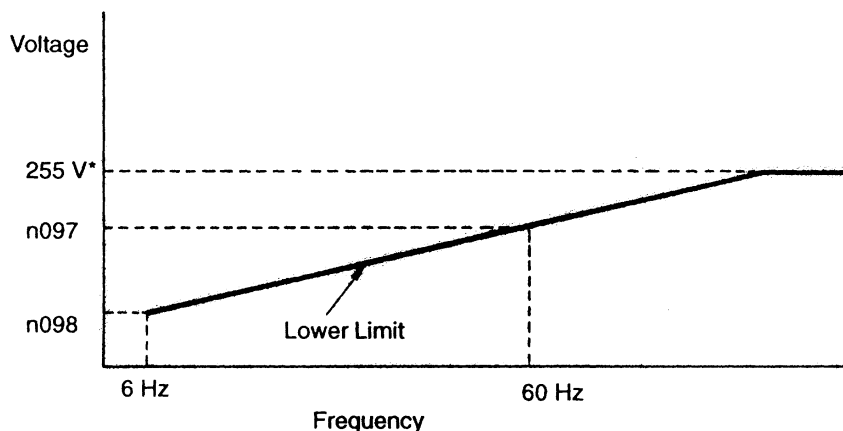

* For 400 V class, the value is twice that of 200 V class.

Figure 50 Energy Saving Voltage Lower Limit

6.9.2. Energy Saving Tuning

In the Energy Saving Control mode, the optimum voltage is calculated according to load power, and the voltage is supplied to the load. However, the set constant may vary due to temperature variations or using other manufacturers' motors, therefore, the optimum voltage may not be supplied in some cases. Automatic tuning controls voltage so that highly efficient operation is maintained.

■ Voltage Limit of Tuning (n100)

Limits the range to control voltage by tuning. Setting is made in a percentage of motor rated voltage. By setting this value to 0, turning is disabled.

■ Step Voltage of Tuning (n100, n101)

Sets voltage variation width of one tuning cycle. Setting is made in a percentage of motor rated voltage. By increasing this value, the rotating speed variation becomes larger. This voltage variation width is set when starting tuning voltage is 100% and motor rated voltage is 5%. Values obtained by linear interpolation are set to any voltage values other than these values.

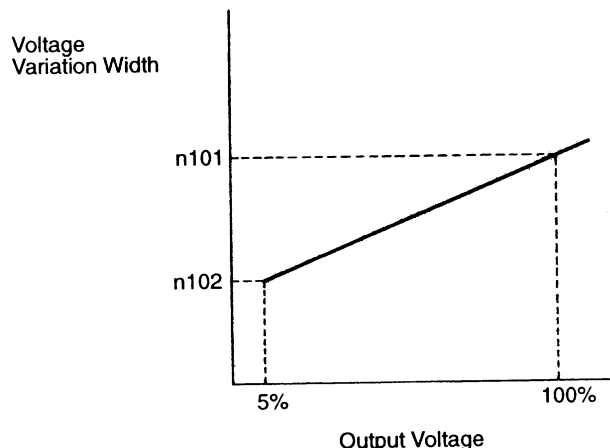

Figure 51 Energy Saving Voltage Variation Width

6.10 MEMOBUS Control

FP5/GP5 can perform serial transmission by using a Programmable Controller (PLC) and MEMOBUS communication. MEMOBUS is composed of one master PLC and 1 to 31 (maximum) slave units (FP5/GP5). In signal transmission (serial transmission) between the master and slaves, the master always starts transmission and the slaves respond to it.

The master performs signal transmission with one slave at a time. Therefore, address numbers are assigned to each slave in advance and the master specifies a number to perform signal transmission. The slave which receives the command from the master executes the function and returns the response to the master.

6.10.1. Communication Specifications

- Interface : RS-485 (Communication interface card SI-K2/P must be mounted.)
- Synchronization : Asynchronous
- Transmission parameter :
 - Baud rate : Selectable from 2400, 4800, 9600 BPS (Constant n107)
 - Data length : Fixed to 8 bits
 - Parity : Parity / no-parity, even / odd selectable (Constant n108)
 - Stop bit : Fixed to 1 bit
- Protocol : In accordance with MEMOBUS
- Maximum number of units to be connected : 31 units (when RS-485 is used)

6.10.2. Data to be Sent/Received by Communication

Data to be sent/received by communication are RUN commands, frequency reference, fault contents, Inverter status and constant setting/reading.

■ Operation Mode Selection (n002)

Select the RUN command and frequency reference input method in constant n002. To provide a RUN command and frequency reference by communication, set this constant to settings 4 to 8. Also, without regard to this selection, monitoring of running status, constant setting/reading, fault reset and multi-function input command from the PLC are enabled. The multi-function input command becomes OR with the command input from control circuit Terminals S2 to S6.



- **MEMOBUS Frequency Reference Unit (n105)**

The frequency reference units from the PLC and in the frequency reference and output frequency monitors (by communication) are selected. The output frequency resolution of the FP5/GP5 is 0.1 Hz. Even if the frequency reference unit is changed to 0.01 Hz in constant n105, the value in the hundredth digit of 0.01 Hz of the received frequency reference is rounded off internally. When 30000/100% in units of 0.1% is selected, the value is rounded off in the same way.

- **MEMOBUS Slave Address (n106)**

The slave address number is set. It is necessary to set the address number so that it will not overlap with the address number of another slave connected on the same transmission line.

NOTE: To change the values set in constants n106 to n108 and enable new settings, it is necessary to turn OFF the power supply, and then turn it ON again.



NOTES:



7

Maintenance and Inspection

This chapter describes basic maintenance and inspection procedures for the FP5/GP5.

7.1	Periodic Inspector.....	64
7.2	Parts Replacement Schedule (Guidelines)	64

**WARNING**

- Never touch high-voltage terminals in the Inverter. Failure to observe this can result in an electrical shock.
- Replace all protective covers before powering up the Inverter. To remove the cover, make sure to shut OFF the Molded Case Circuit Breaker. Failure to observe this can result in an electrical shock.
- Perform maintenance or inspection only after verifying that the CHARGE LED goes OFF, after the main circuit power supply is turned OFF. The capacitors are still charged and can be dangerous.
- Only authorized personnel should be permitted to perform maintenance, inspections or parts replacements. (Remove all metal objects (watches, bracelets, etc.) before operation. Use tools which are insulated against electrical shock.) Failure to observe this can result in an electrical shock.

**CAUTION**

- The control PC board employs CMOS ICs. Do not touch the CMOS elements. They are easily damaged by static electricity.
- Do not connect or disconnect wires or connectors while power is applied to the circuit. Failure to observe this can result in personal injury.

7.1 Periodic Inspection

The FP5/GP5 will function longer if it is kept clean, cool and dry, while observing the precautions listed in 2.3 *Choosing a Location to Mount the Inverter*. Check for tightness of electrical connections, discoloration or other signs of overheating or aging. Use *Table 18* as your inspection guide. Before servicing, turn OFF AC main circuit power and be sure that the CHARGE LED is OFF.

Table 18 Periodic Inspection

Component	Check	Corrective Action
External Terminals, Unit Mounting Bolts, Connectors, etc.	Loose screws.	Tighten.
	Loose connectors.	Tighten.
Heatsink	Build-up of dust and dirt.	Blow with dry compressed air of 39.2×10^4 to 58.8×10^4 Pa (4 to $6\text{kg}\cdot\text{cm}^2$) pressure.
Printed Circuit Board	Accumulation of conductive dust or oil.	Blow with dry compressed air of 39.2×10^4 to 58.8×10^4 Pa (4 to $6\text{kg}\cdot\text{cm}^2$) pressure. If dust and oil cannot be removed, replace the board.
Cooling Fan	For abnormal noise and vibration. Whether the cumulative operation time exceeds 20,000 hours or not.	Replace the cooling fan.
Power Elements	Accumulation of dust and dirt.	Blow with dry compressed air of 39.2×10^4 to 58.8×10^4 Pa (4 to $6\text{kg}\cdot\text{cm}^2$) pressure.
Smoothing Capacitor	Discoloration or odor.	Replace the capacitor or Inverter unit.

7.2 Parts Replacement Schedule (Guidelines)

Replace the following parts periodically, for a long, safe, trouble free working life of FP5/GP5.

Table 19 Parts Replacement Schedule

Parts	Interval (Approximately)	Remarks
Cooling Fan	2 to 3 years	Replace with new one.
Smoothing Capacitor	5 years	Replace with new one. (Decided after inspection.)
Breakers or Relays	—	Decided after inspection.
Fuse	10 years	Replace with new one.
Aluminum Electrolytic Capacitor on PC Board	5 years	Replace with new one. (Decided after inspection.)

NOTE: Operating conditions are as follows:

Ambient temperature : 30°C yearly average

Load factor : 80% or below

Operation rate : 12 hours or below/day



8

Troubleshooting

This chapter describes the Inverter fault display and the fault contents caused by motor/machine malfunctions and the corrective actions to be taken.

8.1	Fault Diagnosis and Corrective Actions	66
8.2	Alarm Display and Explanation	69
8.3	Motor Faults and Corrective Actions	70



Chapter 8: Troubleshooting

8.1 Fault Diagnosis and Corrective Actions

- When the FP5/GP5 detects a fault, the fault is displayed on the Digital Operator and activates the fault contact output and the motor coasts to a stop. Check the cause in the table below and take the corrective actions.
- If the inspections or corrective actions described cannot solve the problem, contact your Saftronics representative immediately.
- To restart, turn ON the reset input signal or press the RESET key or shut OFF the main circuit power supply once, to reset the stop status.
- To change the setting of a constant during fault display, first press the DSPL key to call up the monitor display. Then press DSPL and ENTER keys simultaneously to enter PRGM mode.

NOTE: When a FWD or REV RUN command is input, the Inverter does not receive a fault reset signal. Make sure to reset after turning OFF the FWD or REV RUN command.



Table 20 Fault Diagnosis and Corrective Actions

Fault Display	Description	Details	Corrective Action
U u 1	Main circuit undervoltage (PUV)	Undervoltage in the DC main circuit during running. Detection level: 200 V class: Approximately 190 V or less. 400 V class: Approximately 380 V or less.	<ul style="list-style-type: none"> • Check the power supply wiring. • Correct the line voltage.
U u 2	Control circuit undervoltage (CUV)	Undervoltage in the control circuit during running.	
U u 3	MC fault	The pre-charge contactor opened during running.	
o C	Overcurrent (OC)	The Inverter output current exceeded the OC level.	<ul style="list-style-type: none"> • Check the motor coil resistance. • Extend the accel/decel time. • Check the motor insulation. • Multi-meter check.
o v	Overvoltage (OV)	The main circuit DC voltage exceeded the OV level. Detection level: 200 V class: Approximately 400 V 400 V class: Approximately 800 V	Extend the deceleration time, add braking circuit.
G F	Grounding (GF) Earth fault)	Inverter output grounding current exceeded 50% of Inverter rated current.	<ul style="list-style-type: none"> • Check that motor insulation has not deteriorated. • Check that connection between Inverter and motor is not damaged.
P U F	Main circuit fault (PUF)	<ul style="list-style-type: none"> • The direct current circuit fuse is blown. • The output transistors were damaged. 	Check for damaged transistor, load side short circuit, grounding, etc.
* o H 1	Heatsink overheat (OH1)	The transistor heatsink temperature exceeded the allowable value. (Fin temperature \geq n130: OH1 detection level) (approximately 95°C)	Check the fan and ambient temperature.
o H 2	Heatsink overheat (OH2)	The transistor heatsink temperature exceeded the allowable value. (Fin temperature \geq n134: OH2 detection level) (approximately 105°C)	Check the fan and ambient temperature.
o L 1	Motor overload (OL1)	Inverter output exceeded the motor overload level.	Reduce the load.
o L 2	Inverter overload (OL2)	Inverter output exceeded the Inverter overload level.	Reduce the load, extend the acceleration time.
* o L 3	Overtorque detection (OL3)	Inverter output current exceeded the overtorque detection level (n075).	Reduce the load, extend the acceleration time.
5 C	Load short-circuit (SC)	Inverter output (load) is short-circuited.	<ul style="list-style-type: none"> • Check the motor coil resistance. • Check the motor insulation.
E F O	External fault from serial communication	Fault occurred in the external control circuit.	Check the external control circuit.

* Stopping method selection is available.



Chapter 8: Troubleshooting

Table 20 Fault Diagnosis and Corrective Actions (Continued)

Fault Display	Description	Details	Corrective Action
EF 2	External fault at Terminal S2	Fault occurred in the external control circuit.	Check the condition of the input terminal. If the LED lights when terminal is not connected, replace the Inverter.
EF 3	External fault at Terminal S3		
EF 4	External fault at Terminal S4		
EF 5	External fault at Terminal S5		
EF 6	External fault at Terminal S6		
SP 1	Excessive ripple in bus bar	<ul style="list-style-type: none"> Inverter input power supply has open-phase. Large unbalance in input voltage. 	<ul style="list-style-type: none"> Check the line voltage. Re-tighten the input terminal screws.
SP 0	Output open-phase	Inverter output has open-phase.	<ul style="list-style-type: none"> Check the output wiring. Check the motor impedance. Retighten the output terminal screws.
* CE	MEMOBUS transmission fault	Control data cannot be received normally.	<ul style="list-style-type: none"> Check the transmission devices or signals. Verify the setting of the constant. Refer to 8.1 Fault Diagnosis and Corrective Actions for verification/change of the constant.
rr	Braking transistor failure	The braking transistor has failed.	Replace the Inverter.
rH	Braking Resistor Unit overheat	The Braking Resistor Unit temperature has exceeded the allowable value. (Protects only Inverter built-in type.)	Reduce the regenerative load.
CPF 0	Control circuit fault 1 (CPF0) (Digital Operator transmission fault)	<ul style="list-style-type: none"> Transmission between the Inverter and Digital Operator cannot be established 5 seconds after supplying power. MPU peripheral element check fault (initial). 	<ul style="list-style-type: none"> Insert the Digital Operator connector again. Check the control circuit wiring. Replace the control card.
CPF 1	Control circuit fault 2 (CPF1) (Digital Operator transmission fault)	<ul style="list-style-type: none"> Transmission between the Inverter and Digital Operator is established once after supplying power, but later transmission fault continues for more than 2 seconds. MPU peripheral element check fault (initial). 	<ul style="list-style-type: none"> Insert the Digital Operator connector again. Check the control circuit wiring. Replace the control card.
CPF 4	EEPROM fault (CPF4)	Inverter control unit fault.	Replace the control card.
CPF 5	CPU A/D converter fault (CPF5)		

*Stopping method selection is available.



8.2 Alarm Display and Explanation

Alarms do not activate fault contact outputs and the Inverter returns to its former operation status automatically when the cause is removed. The following table explains the different types of alarms.

Table 21 Alarm Display and Explanation

Alarm Display	Contents	Explanation
U U Blinking	Undervoltage detection	Undervoltage has been detected.
o U Blinking	OV during stop	Main circuit DC voltage exceeds the overvoltage detection level while the Inverter output is OFF.
o H 1 Blinking	Heatsink overheating	Under condition of heatsink temperature \geq [OH1 detection level (approximately 95°C)], continuous operation at OH1 detection is selected.
o L 3 Blinking	Overtorque detection	Under condition of Inverter output current $>$ n075 (overtorque detection level), continuous operation at overtorque detection is selected.
bb Blinking	External baseblock	External baseblock command is input from control circuit terminal.
E F Blinking	Simultaneous FWD/REV RUN commands	Both FWD and REV RUN commands are input simultaneously for over 500 ms.
C A L L Blinking	MEMOBUS transmission waiting	Under condition of n002 (operation method selection) ≥ 4 , the Inverter has not received the normal data from serial communication after power ON. Refer to <i>8.1 Fault Diagnosis and Corrective Actions</i> for verification/change of the constant.
o H 3 Blinking	Inverter overheat pre-alarm	Inverter overheat pre-alarm signal is input from control circuit terminal.
C E Blinking	MEMOBUS transmission error	Continuous operation is selected at MEMOBUS transmission error. Refer to <i>8.1 Fault Diagnosis and Corrective Actions</i> for verification of the constant.
o P E 1	Inverter kVA setting fault	Inverter kVA setting error.
o P E 3	Multi-function contact input setting error	One of the following setting errors occurred in the multi-function contact input selection (n035 to n039): <ul style="list-style-type: none"> • Two or more of the same values are set. • Both 15 and 16 are set at the same time. • Both 22 and 25 are set at the same time.
o P E 5	V/f data setting error	Setting error of n012 to n018 (V/f data).
o P E 6	Constant setting error	One of the following setting errors occurred: <ul style="list-style-type: none"> • Inverter rated current $\times 0.1 >$ n032 (motor rated current), or n032 $>$ Inverter rated current $\times 2$. • n058 (jump frequency 1) \geq n059 (jump frequency 2) – n60 (jump frequency range). • n030 (output frequency upper limit) $<$ n031 (output frequency lower limit).

8.3 Motor Faults and Corrective Actions

- If any of the following faults occurs in the motor, check the cause and provide the relevant corrective action.
- If these inspections and corrective actions cannot solve the problem, contact your Safronics representative immediately.

Table 22 Motor Faults and Corrective Actions

Fault	Check Point	Corrective Action
Motor does not rotate.	Power supply voltage applied to power supply Terminals L1, L2, and L3 (R, S, and T)? Is CHARGED LED ON?	<ul style="list-style-type: none"> • Turn ON power supply. • Turn OFF power supply, and then ON again. • Check power supply voltage. • Make sure terminal screws are tight.
	Use rectifier type voltmeter to test. Is voltage output to output Terminals T1, T2 and T3 (U, V, and W) correct?	Turn OFF power supply, then turn ON again.
	Motor locks due to excessive load?	Reduce the load and release the lock.
	Fault displayed in Digital Operator display?	Check troubleshooting table.
	FWD or REV RUN command entered?	Check the wiring.
	Frequency setting voltage entered?	<ul style="list-style-type: none"> • Correct the wiring. • Check frequency setting voltage.
	Operation mode setting (n002) correct?	Input the correct the set value.
Motor rotation reverses.	Wiring of Terminals T1, T2, and T3 (U, V, and W) correct?	Match wiring to the phase order of the motor leads T1, T2, and T3 (U, V, and W).
	FWD and REV wiring run signals entered?	Correct the wiring.
Motor rotates, but variable speed not available.	Wiring of frequency setting circuit correct?	Correct the wiring.
	Operation mode setting (n002) correct?	With the Digital Operator, check the operation mode selection.
	Load excessively large?	Reduce the load.
Motor RPM too high or too low.	Motor ratings (number of poles, voltage) correct?	Check motor nameplate specifications.
	Accel/decel speed change ratio for gears, etc. correct?	Check speed changer (gears, etc.).
	Maximum frequency set value correct?	Check the maximum frequency set value.
	Use rectifier voltmeter. Voltage between motor terminals not excessively reduced?	Check V/f characteristics values.
Motor RPM not stable during operation.	Load excessively large?	Reduce the load.
	Load variation excessively large?	<ul style="list-style-type: none"> • Reduce the load variation. • Increase Inverter motor capacity.
	3-phase or single-phase power supply used? For 3-phase power supply, open phase?	For 3-phase power supply, check the wiring if power supply is open phase. For single-phase power supply connect AC reactor to the power supply.



9

Specifications

This chapter describes the specifications of the FP5/GP5 Inverter.

9.1	Standard Specifications	72
------------	--------------------------------------	-----------

Chapter 9: Specifications

9.1 Standard Specifications

Table 23 200 V Class Specifications

Series		FP5/GP5											
Models FP5/GP5		23P7	25P5	27P5	2011	2015	2018	2022	2030	2037	2045	2055	2075
Maximum Applicable Motor Output *(kW)		3.7	5.5	7.5	11	15	18.5	22	30	37	45	55	75
Output Characteristics	Inverter Capacity (kVA)	6.7	9.5	13	19	24	30	37	50	61	70	85	110
	Rated Output Current (A)	17.5	25	33	49	64	80	96	130	160	183	224	300
	Maximum Output Voltage	3-Phase, 200/208/220/230 V (Proportional to input voltage)											
	Rated Output Frequency	Up to 400 Hz available by programming											
Power Supply	Rated Input Voltage and Frequency	3-Phase 200/208/220 V 50 Hz 200/208/220/230 V 60 Hz											
	Allowable Voltage Fluctuation	+ 10%, - 15%											
	Allowable Frequency Fluctuation	± 5%											
Control Characteristics	Control Method	Sine wave PWM											
	Frequency Control Range	0.1 to 400 Hz											
	Frequency Accuracy	Digital Command: 0.01% (- 10°C to + 40°C)											
		Analog Command: 0.1% (25°C ± 10°C)											
	Frequency Resolution	Digital Operator reference: 0.1 Hz											
		Analog reference: 0.1 Hz											
	Output Frequency Resolution	0.1 Hz											
	Overload Capacity	150% of rated output current for 1 minute						120% of rated output current for 1 minute					
	Frequency Setting Signal	0 to + 10 V (20kΩ), 4 to 20 mA (250Ω)											
	Accel/Decel Time	0.0 to 3600 sec (Accel/decel time setting independently)											
Braking Torque	Approximately 20% (Approximately 125% with Braking Resistor)						Approximately 20% (Braking Resistor cannot be mounted)						
Number of V/f Patterns	15 preset V/f patterns, 1 custom V/f with voltage limit, 1 custom without voltage limit												
Protective Functions	Motor Overload Protection	Protected by electronic Thermal Overload Relay											
	Instantaneous Overcurrent	Motor coasts to a stop at approximately 200% of Inverter rated current.						Motor coasts to a stop at approximately 180% of Inverter rated current.					
	Overload	Motor coasts to a stop after 1 minute at 150% of rated output current.						Motor coasts to a stop after 1 minute at 120% of rated output current.					
	Overvoltage	Motor coasts to a stop if converter output voltage exceeds 410 V.											
	Undervoltage	Motor coasts to a stop if converter output voltage drops to 190 V or below.											
	Momentary Power Loss	Immediately stop by 15 ms and above momentary power loss. (Factory setting) Continuous operation during power loss less than 2 seconds is equipped as standard.											
	Heatsink Overheat	Protected by thermistor.											
	Stall Prevention	Stall Prevention during accel/decel and constant speed operation.											
	Ground Fault	Protected by electronic circuit.											
	Power Charge Indication	CHARGE LED stays ON until bus voltage drops below 50 V.											
Environment	Ambient Temperature	- 10°C to + 40°C (Enclosed wall-mounted type) - 10°C to + 45°C (Open chassis type)											
	Humidity	90% RH or less											
	Storage Temperature	-20°C to + 60°C											
	Location	Indoor (protected from corrosive gases and dust)											
	Vibration	9.81m/s ² (1G) at 10 to less than 20 Hz, up to 1.96m/s ² (0.2G) at 20 to 50 Hz.											

*Based on a Saftronics standard 4-pole motor for maximum applicable motor output.



Table 24 400 V Class Specifications (FP5/GP5)

Models FP5/GP5		40P4	40P7	41P5	42P2	43P7	44P0	45P5	47P5	4011	4015
Maximum Applicable Motor Output *(kW)		0.55	1.1	1.5	2.2	3.7	4.0	5.5	7.5	11	15
Output Characteristics	Inverter Capacity (kVA)	1.4	2.6	3.7	4.7	6.1	8.4	11	14	21	26
	Rated Output Current (A)	1.8	3.4	4.8	6.2	8	11	14	18	27	34
	Maximum Output Voltage	3-Phase 380/400/415/440/460 V (Proportional to input voltage)									
	Rated Output Frequency	Up to 400 Hz available by programming									
Power Supply	Rated Input Voltage and Frequency	3-Phase 380/400/415/440/460 V 50/60 Hz									
	Allowable Voltage Fluctuation	+ 10%, - 15%									
	Allowable Frequency Fluctuation	± 5%									
Control Characteristics	Control Method	Sine wave PWM									
	Frequency Control Range	0.1 to 400 Hz									
	Frequency Accuracy	Digital Command: ± 0.01% (- 10°C to + 40°C)									
		Analog Command: ± 0.1% (25°C ± 10°C)									
	Frequency Resolution	Digital Operator reference: 0.1 Hz									
		Analog reference: 0.1 Hz									
	Output Frequency Resolution	0.1 Hz									
	Overload Capacity	150% of rated output current for 1 minute									
	Frequency Setting Signal	0 to + 10 V (20kΩ), 4 to 20 mA (250Ω)									
	Accel/Decel Time	0.0 to 3600 seconds (Accel/dec el time setting independently)									
Braking Torque	Approximately 20% (Approximately 125% with Braking Resistor)										
Number of V/f Patterns	15 preset V/f patterns, 1 custom V/f with voltage limit, 1 custom without voltage limit										
Protective Functions	Motor Overload Protection	Protected by electronic Thermal Overload Relay									
	Instantaneous Overcurrent	Motor coasts to a stop at approximately 200% of Inverter rated current.									
	Overload	Motor coasts to a stop after 1 minute at 150% of rated output current.									
	Overvoltage	Motor coasts to a stop if converter output voltage exceeds 820 V.									
	Undervoltage	Motor coasts to a stop if converter output voltage drops to 380 V or below.									
	Momentary Power Loss	Immediately stop by 15 ms and above momentary power loss. (Factory setting) Continuous operation during power loss less than 2 seconds is equipped as standard.									
	Heatsink Overheat	Protected by thermistor.									
	Stall Prevention	Stall Prevention during accel/dec el and constant speed operation.									
	Ground Fault	Protected by electronic circuit.									
Power Charge Indication	Charge LED stays ON until bus voltage drops below 50 V.										
Environment	Ambient Temperature	- 10°C to + 40°C (Enclosed wall-mounted type) - 10°C to + 45°C (Open chassis type)									
	Humidity	90% RH or less									
	Storage Temperature	-20°C to + 60°C									
	Location	Indoor (protected from corrosive gases and dust)									
	Elevation	1000 meters or less									
	Vibration	9.81m/s ² (1G) at 10 to less than 20 Hz, up to 1.96m/s ² (0.2G) at 20 to 50 Hz.									

*Based on a Saftronics standard 4-pole motor for maximum applicable motor output.



Chapter 9: Specifications

Table 25 400 V Class Specifications (FP5/GP5)

Models FP5/GP5		4018	4022	4030	4037	4045	4055	4075	4110	4160	4185	4220	4300
Maximum Applicable Motor Output * (kW)		18.5	22	30	37	45	55	75	110	160	185	220	300
Output Characteristics	Inverter Capacity (kVA)	31	40	50	61	73	98	130	170	230	260	340	460
	Rated Output Current (A)	41	52	65	80	96	128	165	224	302	340	450	605
	Maximum Output Voltage	3-Phase, 380/400/415/440/460 V (Proportional to input voltage)											
	Rated Output Frequency	Up to 400 Hz available by programming											
Power Supply	Rated Input Voltage and Frequency	3-Phase 380/400/415/440/460 V 50/60 Hz											
	Allowable Voltage Fluctuation	+ 10%, - 15%											
	Allowable Frequency Fluctuation	± 5%											
Control Characteristics	Control Method	Sine wave PWM											
	Frequency Control Range	0.1 to 400 Hz											
	Frequency Accuracy	Digital Command: ± 00.1% (- 10°C + 40°C)											
		Analog command: ± 0.1% (25°C ± 10°C)											
	Frequency Resolution	Digital Operator reference: 0.1 Hz											
		Analog reference: 0.1 Hz											
	Output Frequency Resolution	0.1 Hz											
	Overload Capacity	120% of rated output current for 1 minute.											
	Frequency Setting Signal	0 to + 10 V (20kΩ), 4 to 20 mA (250Ω)											
	Accel/Decel Time	0.0 to 3600 seconds (Accel/decel time setting independently)											
Braking Torque	Approximately 20% (Braking Resistor cannot be mounted)						Approximately 20% (Approximately 100% with Braking Unit and Braking Resistor)						
Number of V/f Patterns	15 preset V/f patterns, 1 custom V/f with voltage limit, 1 custom without voltage limit												
Protective Functions	Motor Overload Protection	Protected by electronic Thermal Overload Relay											
	Instantaneous Overcurrent	Motor coasts to a stop at approximately 180% of Inverter rated current.											
	Overload	Motor coasts to a stop after 1 minute at 120% of rated output current.											
	Overvoltage	Motor coasts to a stop if converter output voltage exceeds 820 V.											
	Undervoltage	Motor coasts to a stop if converter output voltage drops to 380 V or below.											
	Momentary Power Loss	Immediately stop by 15 ms and above momentary power loss. (Factory setting) Continuous operation during power loss less than 2 seconds is equipped as standard.											
	Heatsink Overheat	Protected by thermistor.											
	Stall Prevention	Stall Prevention during accel/decel and constant speed operation.											
	Ground Fault	Protected by electronic circuit.											
Power Charge Indication	CHARGE LED stays ON until bus voltage drops below 50 V.												
Environment	Ambient Temperature	- 10°C to + 40°C (Enclosed wall-mounted type) - 10°C to + 45°C (Open chassis type)											
	Humidity	90% RH or less											
	Storage Temperature	-20°C to + 60°C											
	Location	Indoor (protected from corrosive gases and dust)											
	Elevation	1000 meters or less											
	Vibration	9.81m/s ² (1G) at 10 to less than 20 Hz, up to 1.96m/s ² (0.2G) at 20 to 50 Hz.											

*Based on a Saftronics standard 4-pole motor for maximum applicable motor output.



10

Dimensions

The following chapter describes the dimensions of the FP5/GP5.

10.1	Dimensions.....	76
-------------	------------------------	-----------

10.1 Dimensions

The figures below show a 200V 3.7kW model. Use open chassis type 200V/400V 15kW or less with the top and bottom covers removed.

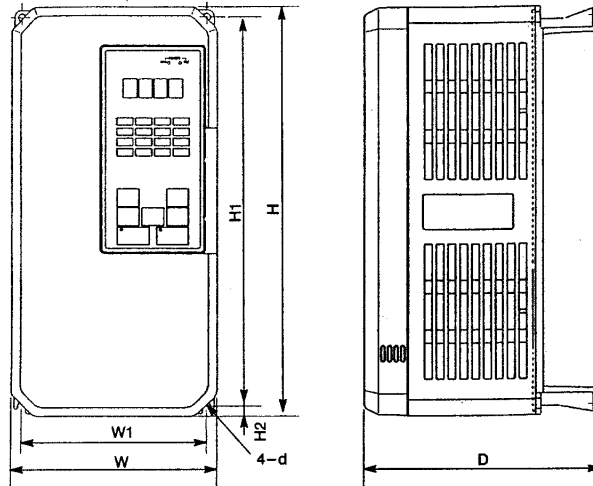
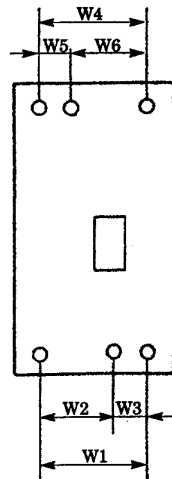

Figure 52 Dimensions of FP5/GP5

The following figure shows the mounting dimensions of 400V 185 to 300kW.



Maximum Applicable Motor Output (kW)	W1	W2	W3	W4	W5	W6
185, 220	750	440	310	850	285	565
300	750	440	310	873	298	575

Figure 53 Mounting Dimensions of 400V 185 to 300kW



Table 26 FP5/GP5 Dimensions (mm) and Approximate Mass (kg)

Voltage	Motor Capacity (kW)	Open Chassis Type (IP00)							Enclosed Wall-mounted type (NEMA1/IP20)								
		W	H	D	W1	H1	H2	Mass (kg)	W	H	H	W1	H1	H2	Mass (kg)	d * ¹	
200V Class	3.7	140	280	180	126	266	7.0	4.5	140	280	180	126	266	7.0	4.5	M5	
	5.5	200	300	205	186	285	8.0	5.5	200	300	205	186	285	8.0	5.5	M6	
	7.5							6							6		
	11	250	380	225	236	365	7.5	11	250	380	225	236	365	7.5	11	M6	
	15									400				27.5			
	18.5	325	450	285	275	435	7.5	28	330	610	285	275	435	87.5	32	M6	
	22									675				152.5			
	30	425	675	350	320	650	12.5	61	430	985	350	320	650	212.5	67	M10	
	37							62							68		
	45	475	800	350	370	775	12.5	80	480	1110	350	370	775	212.5	87	M10	
55																	
75	575	925	400	445	895	15.0	135	580	1290	400	445	895	270	145	M12		
400V Class	0.55	140	280	160	126	266	7.0	3	140	280	160	126	266	7.0	3	M5	
	1.1																
	1.5	140	280	180	126	266	7.0	4	140	280	180	126	266	7.0	4	M5	
	2.2							4.5							4.5		
	3.7																
	4.0																
	5.5																
	7.5	200	300	205	186	285	8.0	6	200	280 300	205	186	285	8.0	6	M6	
	11	250	380	225	236	365	7.5	11	250	380	225	236	365	7.5	11	M6	
	15																
	18.5	325	450	285	275	435	7.5	29	330	610	285	275	435	87.5	32	M6	
	22							31							34		
	30	325	625	285	275	610	7.5	44	330	785	285	275	610	87.5	48	M6	
	37									850							152.5
	45																
	55	455	820	350	350	795	12.5	81	460	1130	350	350	795	212.5	87	M10	
	75							82							88		
	110	575	925	375	445	895	15.0	135	580	1290	375	445	895	270.0	145	M12	
160	400			145				400			155						
185	950	1450	435	*2	1400	25	360	—							M12		
220																	
300								960	1600	455	*2	1550	25	420			

*1 Mounting holes are the same for the open chassis type and the enclosed wall-mounted type.

*2 Refer to the mounting dimensions on Page 76.



NOTES:



11

Typical Connection Diagram

This chapter describes the connection diagrams for the GP5.

11.1	Braking Resistor Unit	80
11.2	Braking Unit and Braking Resistor Unit.....	81

Chapter 11: Typical Connection Diagram

11.1 Braking Resistor Unit

For Models GP5 23P7 to – GP5 27P5 (200 V Class 3.7 to 7.5 kW).

Models GP5 40P4 TP – GP5 4015 (400 V Class 0.4 to 15 kW).

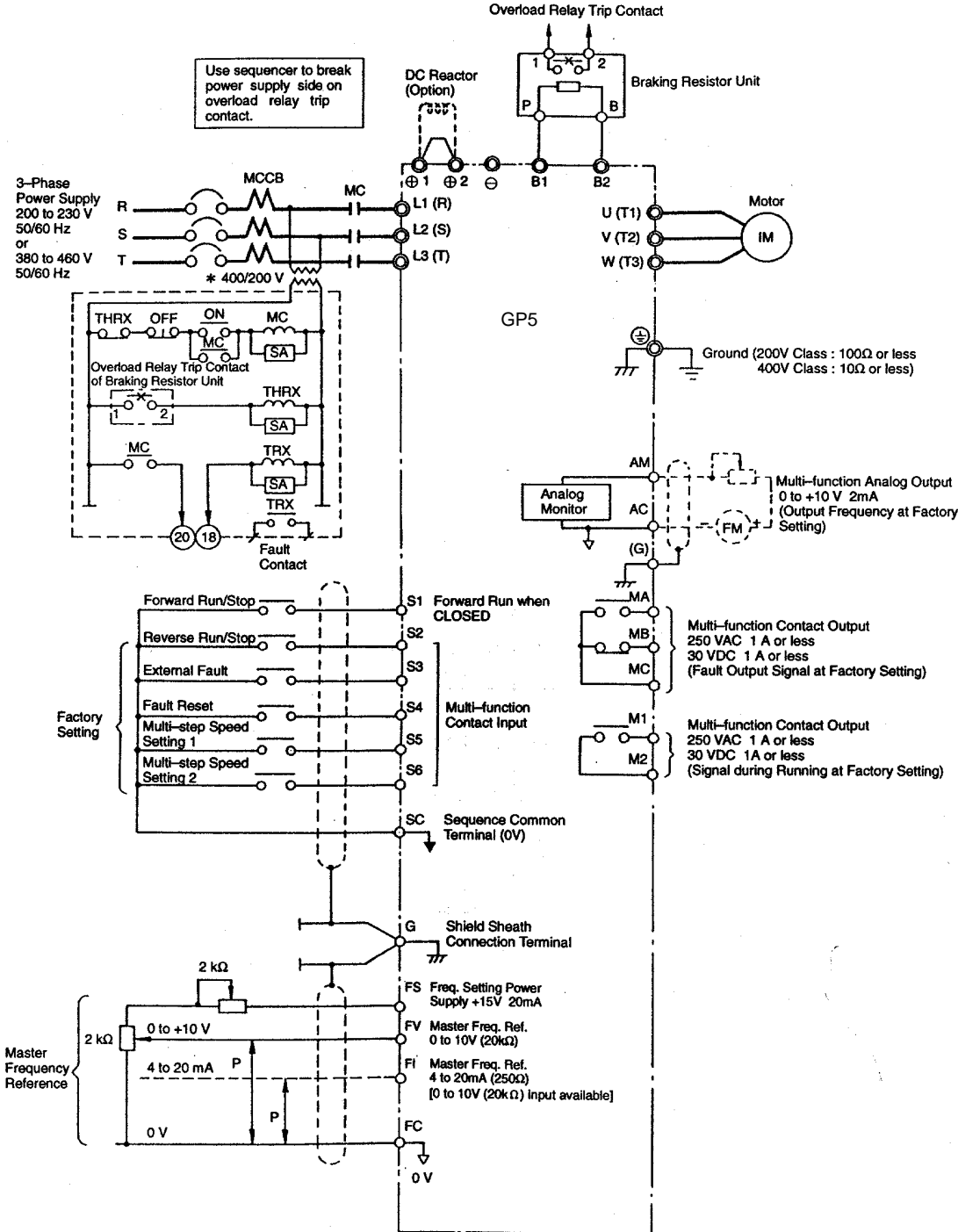

- † The transformer is not necessary for 200V class.
- ‡ When installing a DC Reactor (option), remove the common bar between ⊕1 and ⊕2 terminals (provided as standard) and connect a DC Reactor with the terminals.
- # When using the Thermal Overload Relay, set constant n070 to 0. (Stall Prevention selection during decel is disabled.) If it is not changed, the Inverter may not stop within set decel time.

Figure 54 Connection Diagram for Braking Resistor



11.2 Braking Unit and Braking Resistor Unit

For models GP5 2011, – GP5 2015 (200 V Class 11, 15 kW).

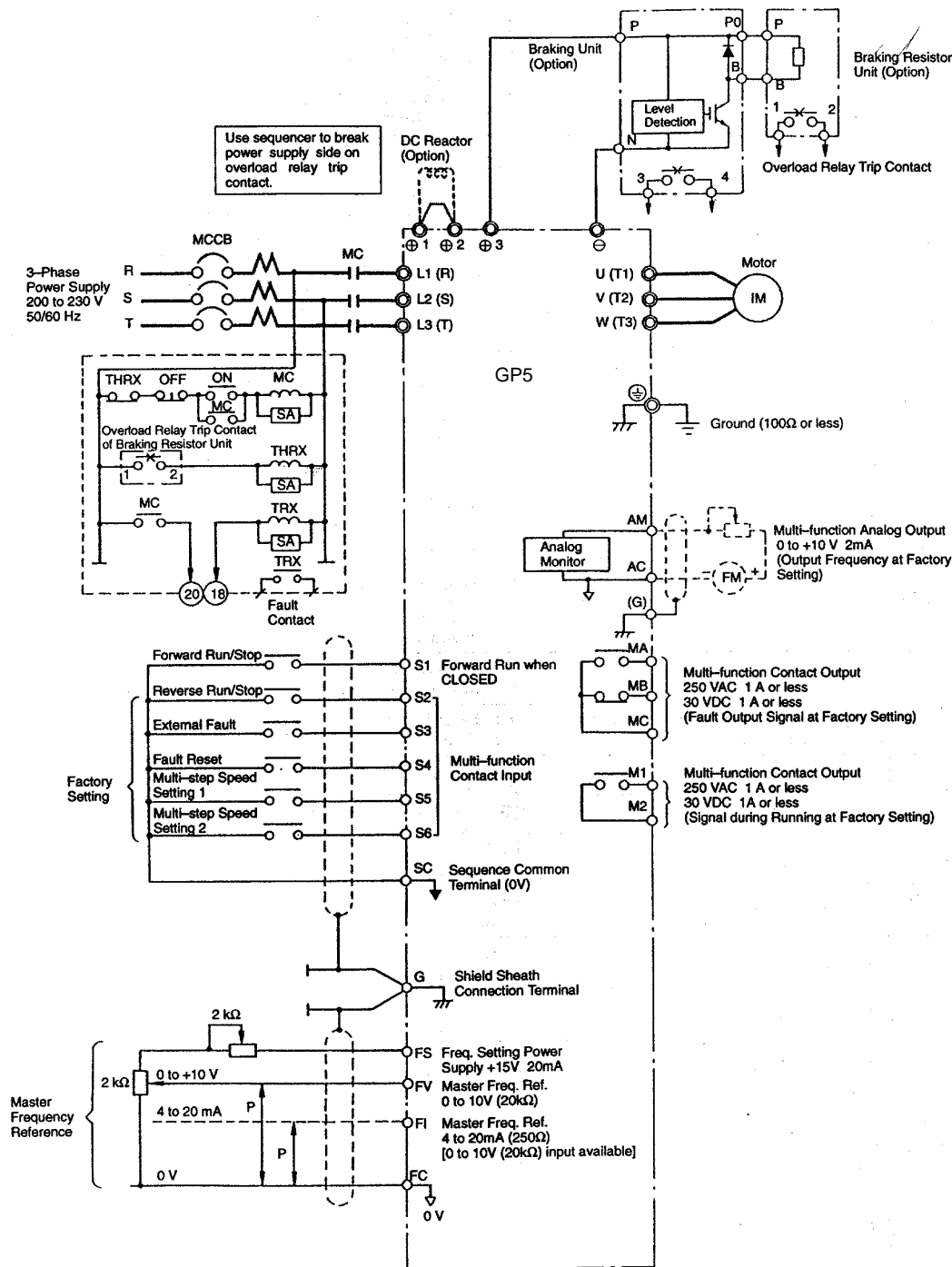

† When installing a DC Reactor (option), remove the common bar between ① and ② terminals (provided as standard) and connect a DC Reactor with the terminals.

‡ When using the Thermal Overload Relay, set constant n070 to 0. (Stall Prevention selection during decel is disabled.) If it is not changed, the Inverter may not stop within set decel time.

NOTE: Braking Unit or Thermal Overload Relay cannot be connected to Inverters of 200V class 18.5 to 75kW or 400V class 18.5 to 160 kW.

Figure 55 DC Connection Diagram for Braking Unit and Braking Resistor



NOTES:



12

Constant List

This chapter lists the constants for the FP5/GP5.

12.1	Constant List	84
-------------	----------------------------	-----------



Chapter 12: Constant List

12.1 Constant List

Table 27 Constant List

Constant	Function Name	Description	Factory Setting
n001	Password	0 : n001 read and set, n002 to n108 read only 1 : n001 to n034 read and set, n035 to n108 read only 2 : n001 to n049 read and set, n050 to n108 read only 3 : n001 to n108 read and set 4 : Not used 5 : Not used 6 : 2-wire initialization – reset (Japanese standard) 7 : 3-wire initialization – reset (Japanese standard) 8 : 2-wire initialization – reset (U.S. specifications) 9 : 3-wire initialization – reset (U.S. specifications) 10 : 2-wire initialization – reset (European specifications) 11 : 3-wire initialization – reset (European specifications)	1
n002	Operation mode selection	(Setting) (Operation) (Reference) 0 : Operator Operator 1 : Terminal Operator 2 : Operator Terminal 3 : Terminal Terminal 4 : Operator Serial com 5 : Terminal Serial com 6 : Serial com Serial com 7 : Serial com Operator 8 : Serial com Terminal	3
n003	Input voltage	Unit : 0.1V Setting range : 150.0 to 255.0V (510V for 400V units)	200.0V (400.0V)
n004	Stopping method selection	0 : Deceleration to stop 1 : Coast to stop 2 : Coast to stop with timer 1 3 : Coast to stop with timer 2	0
n005	Power rotation	0 : CCW 1 : CW	0
n006	Reverse run prohibit	0 : Reverse run enabled 1 : Reverse run disabled	0
n007	LOCAL/REMOTE key function	0 : Disabled 1 : Enabled	1
n008	Stop key function	0 : STOP key is effective when operated from Digital Operator 1 : STOP key is always effective	1
n009	Frequency reference setting method from Digital Operator	0 : ENTER key not used 1 : ENTER key used	1
n010	V/f pattern selection (same as V/f LED)	0 to E : 15 preset V/f patterns F : Custom V/f pattern with voltage limit FF : Custom V/f pattern without voltage limit	1
n011	Motor rated voltage (same as Vmtr LED)	Unit : 0.1V Setting range : 150.0 to 255.0V (510 V for 400V units)	200.0V
n012	Maximum output frequency	Unit : 0.1Hz Setting range : 50.0 to 400.0Hz	60.0 Hz
n013	Maximum voltage	Unit : 0.1V Setting range : 0.1 to 255.0V (510 V for 400V units)	200.0V
n014	Maximum voltage output frequency	Unit : 0.1Hz Setting range : 0.2 to 400.0V	60.0Hz
n015	Middle output frequency	Unit : 0.1Hz Setting range : 0.1 to 399.9Hz	3.0Hz
n016	Middle frequency voltage	Unit : 0.1V Setting range : 0.1 to 255.0V (510V for 400V units)	15.0V
n017	Minimum output frequency	Unit : 0.1Hz Setting range : 0.1 to 10.0Hz	1.5Hz
n018	Minimum output frequency voltage	Unit : 0.1V Setting range : 0.1 to 50.0V	10.0V
n019	Acceleration time 1 (same as Accel LED)	Unit : 0.1 seconds (1 seconds for 1000 seconds and above) Setting range : 0.0 to 3600 seconds	10.0 seconds
n020	Deceleration time 1 (same as Decel LED)	Unit : 0.1 sec (1 seconds for 1000 seconds and above) Setting range : 0.0 to 3600 seconds	10.0 seconds
n021	Acceleration time 2	Unit : 0.1 seconds (1 seconds for 1000 seconds and above) Setting range : 0.0 to 3600 seconds	10.0 seconds



Table 27 Constant List (Continued)

Constant	Function Name	Description	Factory Setting
n022	Deceleration time 2	Unit : 0.1 seconds (1 seconds for 1000 seconds and above) Setting range: 0.0 to 3600 seconds	10.0 seconds
n023	S-curve selection	(Setting) (S-curve time) 0 : S-curve not provided 1 : 0.2 seconds 2 : 0.5 seconds 3 : 1.0 seconds	1
n024	Display mode	(Setting) (Unit) 0 : 0.1 Hz 2 to 39 : RPM (input # of motor poles) 40 to 3999 : custom	0
n025	Frequency reference 1 (same as Fref LED)	Setting depends on n024 setting Range : 0 to 9999	0.0Hz
n026	Frequency reference 2	Setting depends on n024 setting Range : 0 to 9999	0.0Hz
n027	Frequency reference 3	Setting depends on n024 setting Range : 0 to 9999	0.0Hz
n028	Frequency reference 4	Setting depends on n024 setting Range : 0 to 9999	0.0Hz
n029	Jog frequency	Setting depends on n024 setting Range : 0 to 9999	6.0Hz
n030	Frequency reference upper limit	Unit : 1% Setting range : 0 to 100%	100%
n031	Frequency reference lower limit	Unit : 1% Setting range : 0 to 100%	0%
n032	Motor rated current (same as FLA LED)	Unit: 0.1A Range: 10 to 200% INV rated Unit is 1A, when setting is more than 1000A	kVA dependent
n033	Motor overload protection selection (OL1)	(Setting) (Characteristics) 0 : No protection 1 : Standard motor (time constant 8 minutes) 2 : Standard motor (time constant 5 minutes) 3 : Inverter motor (time constant 8 minutes) 4 : Inverter motor (time constant 5 minutes)	1
n034	Stopping method selection (OH1)	(Setting) (Stop Method) 0 : Ramp to stop – Decel 1 (fault) 1 : Coast to stop (fault) 2 : Ramp to stop – Decel 2 (fault) 3 : Inverter motor (time constant 8 minutes)	3
n035	Multi-function contact input selection (Terminal S2)	0 : REV RUN command (2-wire sequence) 1 : FWD/REV RUN command (3-wire sequence) 2 : External fault (NO contact input) 3 : External fault (NC contact input) 4 : Fault reset 5 : LOCAL/REMOTE selection 6 : Serial communication/control circuit terminal selection 7 : Fast stop 8 : Master frequency reference input level selection 9 : Multi-step speed reference 10 : Multi-step speed reference 11 : Jog frequency selection 12 : Accel/decel time selection 13 : External baseblock (NO contact input) 14 : External baseblock (NC contact input) 15 : Search command from maximum frequency 16 : Search command from set frequency 17 : Constant setting enable/disable 18 : PID integral value reset 19 : PID Control disable 20 : Timer function 21 : OH3 (Inverter overheat alarm) 22 : Analog reference sample/hold	0
n036	Multi-function contact input selection (Terminal S3)	Set items are same as n035	2
n037	Multi-function contact input selection (Terminal S4)	Set items are same as n035	4

Chapter 12: Constant List

Table 27 Constant List (Continued)

Constant	Function Name	Description	Factory Setting
n038	Multi-function contact input selection (Terminal S5)	Set items are same as n035	9
n039	Multi-function contact input selection (Terminal S6)	Set items are same as n035 25 : UP/DOWN command 26 : Loop test (MEMOBUS)	10
N040	Multi-function contact output selection (Terminal MA-MB-MC)	0 : Fault 1 : During running 2 : Frequency agree 3 : Desired frequency agree 4 : Frequency detection 1 5 : Frequency detection 2 6 : Overtorque detection (NO contact) 7 : Overtorque detection (NC contact) 8 : During baseblock 9 : Operation mode 10 : Inverter operation ready 11 : Timer function 12 : Automatic restart 13 : OL pre-alarm 14 : Frequency reference loss 15 : Output from serial communication (DO function) 16 : PID feedback loss 17 : OH1 alarm	0
n041	Multi-function contact output selection (Terminal M1-M2)	Set items are as same as n040	1
n042	Master analog input selection (FV or FI Terminal)	0 : 0 to 10V input (FV) 1 : 4 to 20mA input (FI)	0
n043	Auxiliary analog input selection (FI Terminal)	0 : 0 to 10V input (Jumper must be cut) 1 : 4 to 20mA input	1
n044	Frequency reference retention	0 : Held reference retained in frequency reference 1 (constant n025) 1 : Not retained	0
n045	Operation method for freq. ref. loss detection	0 : No detection 1 : Continue to run at 80% previous ref.	0
n046	Frequency reference gain (same as Fgain LED)	Unit : 1% Setting range : 0 to 200%	100%
n047	Frequency reference bias (same as Fbias LED)	Unit : 1% Setting range : - 100 to 100%	0%
n048	Multi-function analog output (AM-AC)	(Setting) (Monitor) 0 : Output frequency 1 : Output current 2 : Output power 3 : DC bus voltage	0
n049	Analog monitor gain	Unit : 0.01 Setting range : 0.01 to 2.00	1
n050	Carrier frequency	1, 2, 4, 5, 6 : Set value × 2.5kHz 3 : 8.0kHz 7, 8, 9 : Proportional to output frequency of 2.5kHz maximum	kVA dependent
n051	Momentary power loss ridethrough method	(Setting) (Method) 0 : Not provided 1 : Continuous operation after power recovery within the time set in n055 2 : Continuous operation after power recovery within control logic time (no fault output)	0
n052	Speed search level (decel time is 2 seconds except 4 seconds for 200V/400V, 55kW or above)	Unit : 1% Setting range : 0 to 200% 100% = INV rated current	110%
n053	Minimum baseblock time	Unit : 0.1 seconds Setting range : 0.5 to 5.0 seconds	kVA dependent
n054	V/f reduction level during speed search	Unit : 1% Setting range : 0 to 100%	kVA dependent
n055	Power loss ridethru time	Unit : 0.1 seconds Setting range : 0.0 to 2.0 seconds	kVA dependent



Table 27 Constant List (Continued)

Constant	Function Name	Description	Factory Setting	
n056	Automatic retry attempts	Unit : 1 time Setting range: 0 to 10	0	
n057	Fault contact selection during automatic retry	0 : Closed during fault retry 1 : Open during fault retry	0	
n058	Jump frequency 1	Unit : 0.1Hz Setting range: 0.0 to 400.0Hz	0.0Hz	
n059	Jump frequency 2	Unit : 0.1Hz Setting range: 0.0 to 400.0Hz	0.0Hz	
n060	Jump frequency range	Unit : 0.1Hz Setting range: 0.0 to 400.0Hz	1.0Hz	
n061	Elapsed timer selection	0 : Accumulated time during power on 1 : Accumulated time during running	1	
n062	Elapsed timer 1	Unit : 1 hour Range : 0 to 9999	0	
n063	Elapsed timer 2	Unit : 10,000 hours Range : 0 to 27	0	
n064	DC Injection Braking current	Unit : 1% Setting range: 0 to 100% 100% = INV rated current	50%	
n065	DC Injection Braking time at stop	Unit : 0.1 seconds Range : 0.0 to 10.0 seconds	0.5 seconds	
n066	DC Injection Braking time at start	Unit : 0.1 seconds Range : 0.0 to 10.0 seconds	0.0 seconds	
n067	Torque compensation gain	Unit : 0.1 Range : 0.0 to 3.0	1.0	
n068	Motor line to line resistance	Unit : 0.001 Ω (0.01 Ω for 10.00 Ω or above) Setting range: 0.000 to 65.53	Normally, no adjustment is necessary. kVA dependent	
n069	Iron loss	Unit : 0W Setting range: 0 to 9999W		kVA dependent
n070	Stall Prevention during deceleration	0 : Disabled 1 : Enabled		1
n071	Stall Prevention level during acceleration	Unit : 1% Setting range: 30 to 200% When level is set to 200%, Stall Prevention during acceleration is disabled.	kVA dependent	
n072	Stall Prevention level during running	Unit : 1% Setting range: 30 to 200% When level is set to 200%, Stall Prevention running is disabled.	kVA dependent	
n073	Frequency detection (multi-function contact output)	Unit : 0.1Hz Setting range: 0.0 to 400Hz	0.0Hz	
n074	Overtorque detection function selection (OL3)	(Setting) (Function) 0 : Detection disabled 1 : Detected during constant-speed running, and operation continues after detection. 2 : Detected during running, and operation continues after operation 3 : Detected during constant-speed running, and Inverter output is shut OFF during detection. 4 : Detected during running, and Inverter output is shut OFF during detection.	0	
n075	Overtorque detection level (OL3)	Unit : 1% Setting range: - 30 to 200% 100% = INV rated current	160%	
n076	Overtorque detection time (OL3)	Unit : 0.1 seconds Setting range: 0.0 to 10.0 seconds	0.1 seconds	
n077	ON-delay timer	Unit : 0.1 seconds Setting range: 0.0 to 25.5seconds	0.0 seconds	
n078	OFF-delay timer	Unit : 0.1 seconds Setting range: - 0.0 to 25.5 seconds	0.0 seconds	
n079	dB resistor overheat function (rH)	0 : No dB protection calculated or provided 1 : Protection provided for installed Safronics resistor only	0	
n080	Input phase loss detection level (SPI)	Unit : 1% Setting range: 1 to 100% When setting is 100%, this function is disabled	7%	
n081	Input phase loss detection delay time (SPI)	Unit : 1 (1.28 seconds) Setting range: 2 to 255 (2.56 to 326.4 seconds)	(10.24 seconds)	

Chapter 12: Constant List

Table 27 Constant List (Continued)

Constant	Function Name	Description	Factory Setting
n082	Output phase loss detection level (SPO)	Unit : 1% Setting range: 0 to 100%	0%
n083	Output phase loss detection delay time (SPO)	Unit : 0.1 seconds Setting range: 0.0 to 2.0 seconds	0.2 seconds
n084	PID selection (same as PID LED)	0 : PID disabled 1 : PID enabled (Deviation is D-controlled) 2 : PID with feed forward (Feedback value is D-controlled) 3 : PID with feed forward (Feedback is reversed characteristics)	0
n085	Feedback calibration gain (PID)	Unit : 0.01 Setting range: 0.00 to 10.00	1.00
n086	Proportional gain (PID)	Unit: : 0.1 Setting range: 0.0 to 10.0	1.0
n087	Integral time (PID)	Unit : 0.1 seconds Setting range: 0.0 to 100.0 seconds	10.0 seconds
n088	Derivative time (PID)	Unit : 0.1 seconds Setting range: 0.0 to 100.0 seconds	0.00 seconds
n089	Offset (PID)	Unit : 1% Setting range: - 109 to 109%	0%
n090	Limit of integral value (PID)	Unit : 1% Setting range: 0 to 109%	100%
n091	Output lag filter time (PID)	Unit : 0.1 seconds Setting range: 0.0 to 2.5 seconds	0.0 seconds
n092	Feedback loss detection (PID)	0 : Detection is disabled 1 : Detection is enabled	0
n093	Feedback loss detection level(PID)	Unit : 1% Setting range: 0 to 100%	0%
n094	Feedback loss detection delay time (PID)	Unit : 0.1 seconds Setting range: 0.0 to 25.5 seconds	1.0 seconds
n095	Energy Saving selection (same as kWsav LED)	0 : Energy Saving is disabled 1 : Energy Saving is enabled	0
n096	Energy Saving gain K2	Unit : 0.01 (0.1 for 100.0 or above) Setting range: 0.00 to 655.0	kVA dependent
n097	Energy Saving voltage lower limit at 60Hz	Unit : 1% Setting range: 0 to 120%	50%
n098	Energy Saving voltage lower limit at 6Hz	Unit : 1% Setting range: 0 to 25%	12%
n099	Time of average k W (Energy Saving)	Unit : 1 = 25ms Setting range: 1 to 200	1
n100	Voltage limit of tuning (Energy Saving)	Unit : 1% Setting range: 0 to 100%	0%
n101	Step voltage of tuning at 100% output voltage (Energy Saving)	Unit : 0.1% Setting range: 0.1 to 10.0%	0.5%
n102	Step voltage of tuning at 5% output voltage (Energy Saving)	Unit : 0.1% Setting range: 0.1 to 10.0%	0.2%
n103	MEMOBUS time over detection	0 : Time over detection is disabled 1 : Time over detection is enabled	1
n104	MEMOBUS stop method at communication error (CE)	(Setting) (Stop Method) 0 : Ramp to stop – Decel 1 (fault) 1 : Coast to stop (fault) 2 : Ramp to stop – Decel 2 (fault) 3 : Continue operation (alarm)	1
n105	MEMOBUS frequency reference unit	(Setting) (Frequency Unit) 0 : 0.1Hz / 1 1 : 0.01Hz / 1 2 : 100% / 30000 3 : 0.1% / 1	0
n106	MEMOBUS slave address	Unit : 1 Setting range: 0 to 31	0
n107	MEMOBUS BPS selection	(Setting) (BPS Rate) 0 : 2400 BPS 1 : 4800 BPS 2 : 9600 BPS	2
n108	MEMOBUS parity selection	(Setting) (BPS Rate) 0 : No parity 1 : Even parity 2 : Odd parity	1



Table 27 Constant List (Continued)

Constant	Function Name	Description	Factory Setting
n109*	Slip compensation gain	Unit: : 0.1% Setting range: 0.0 to 9.9%	0.0%
n110*	Motor no-load current	Unit: : 1% Setting range: 0 to 99%	30%
n111*	Primary delay time constant	Unit : 0.1 seconds Setting range: 0.0 to 25.5 seconds	2.0 seconds
n112*	Digital Operator connection fault detection	0 : Connection fault detection is disabled 1 : Connection fault detection is enabled	0
n113*	Frequency agree detection width selection	Unit : 0.1Hz Setting range: 0.0 to 25.5Hz	2.0Hz
n114*	Function selection at LOCAL/REMOTE switching	0 : At LOCAL/REMOTE switching, restart is enabled after stop command is input. 1 : At LOCAL/REMOTE switching, restart is enabled at once.	0
n115*	kVA selection	Unit : 1 Setting range: GP5 (VSP2010): 0 to 8, 20 to 29 FP5 (VSP3010): 9 to F, 2A to 35	—
n116	CT/VT Selection	0 : Constant Torque 1 : VariableTorque	
n117	Low Frequency OL Starting Point	Unit : 0.1Hz Setting range: 0.0 to 10.0Hz	6.0Hz
n118	0Hz Continuous Operation level	Unit : 1% Setting range: 25 to 100%	50%

* These constants are disabled for former softwares VSP1010 to VSP1015. Enabled for the following software number (or after).

GP5 : VSP2010
FP5 : VSP3010



NOTES:



13

Digital Operator Monitor Display

This chapter describes the monitor displays of the Digital Operator of the FP5/GP5.

13.1	Digital Operator Monitor Display	92
-------------	---	-----------

Chapter 13: Digital Operator Monitor Display

13.1 Digital Operator Monitor Display

The following table shows the contents of the Digital Operator monitor display.

Table 28 Digital Operator Monitor Display

LED	Name	Description														
Fref	Frequency reference	<ul style="list-style-type: none"> Frequency reference can be monitored/set. Setting/display unit depends on display mode (n024). 														
Fout	Output frequency	<ul style="list-style-type: none"> Output frequency can be monitored. Display unit depends on display mode (n024). 														
Iout	Output current	Output current can be monitored in units of 0.1 A (1 A for 1000 A and above).														
kWout	Output voltage	Output voltage can be monitored in units of 0.1 kW (1 kW for 1000 k and above).														
F/R	FWD/REV RUN command	<ul style="list-style-type: none"> FWD/REV RUN command can be set/monitored. Setting enabled during RUN command from Digital Operator. FWD run displays For, REV run displays rev. 														
Montr	Monitor	The following contents can be monitored.														
		<table border="1"> <thead> <tr> <th>No.</th> <th>Contents</th> </tr> </thead> <tbody> <tr> <td>U-01</td> <td>Frequency reference (same as Fref)</td> </tr> <tr> <td>U-02</td> <td>Output frequency (same as Fout)</td> </tr> <tr> <td>U-03</td> <td>Output current (same as Iout)</td> </tr> <tr> <td>U-04</td> <td>Output voltage reference can be monitored in units of 1 V</td> </tr> <tr> <td>U-05</td> <td>DC voltage can be monitored in units of 1 V</td> </tr> <tr> <td>U-06</td> <td>Output power (same as kWout)</td> </tr> </tbody> </table>	No.	Contents	U-01	Frequency reference (same as Fref)	U-02	Output frequency (same as Fout)	U-03	Output current (same as Iout)	U-04	Output voltage reference can be monitored in units of 1 V	U-05	DC voltage can be monitored in units of 1 V	U-06	Output power (same as kWout)
		No.	Contents													
		U-01	Frequency reference (same as Fref)													
		U-02	Output frequency (same as Fout)													
		U-03	Output current (same as Iout)													
		U-04	Output voltage reference can be monitored in units of 1 V													
		U-05	DC voltage can be monitored in units of 1 V													
		U-06	Output power (same as kWout)													
		U-07	Input terminal status can be monitored (Terminals S1 to S6) 													
U-08	Inverter status can be monitored 															



Table 28 Digital Operator Monitor Display (Continued)

LED	Name	Description	
Montr	Monitor	No.	Contents
		U-09	Maximum 4 faults can be monitored.
		U-10	Lower 4 digits of PROM number can be monitored.
		U-11 U-12	<p>Elapsed time can be monitored as follows.</p> <p>X X X X X ← Elapsed time (in units of 1 hour)</p> <p>U-10 (lower 4 digits) U-11 (upper 2 digits)</p> <p>Maximum 279,620 hours</p>
		U-13	PID feedback can be monitored. Display unit depends on the setting of n024.
Accel	Acceleration time 1	Acceleration time 1 (n019) can be set/read in units of 0.1 seconds (1 seconds for 1000 sec and above).	
Decel	Deceleration time 1	Deceleration time 1 (n020) can be set/read in units of 0.1 seconds (1 seconds for 1000 sec and above).	
Vmtr	Motor rated voltage	Motor rated voltage (n011) can be set during stop.	
V/f	V/f pattern selection	V/f pattern selection (n010) can be set during stop.	
Fgain	Frequency reference gain	Frequency reference gain (n046) can be set during stop.	
Fbias	Frequency reference bias	Frequency reference bias (n047) can be set during stop.	
FLA	Motor rated current	Motor rated current (n032) can be set during stop.	
PID	PID selection	PID selection (n084) can be set during stop.	
kWsav	Energy Saving selection	Energy Saving selection (n095) can be set during stop.	
PRGM	PRGM mode	Constants can be set/read.	



NOTES:

INDEX

3-phase power supply, 10

A

AC reactor, 11
 accel/decel time, 70
 acceleration time, 84, 92
 adjusting frequency setting signal, 40
 adjusting frequency upper and lower limits, 41
 alarm display, 69
 allowable frequency fluctuation, 70
 allowable voltage fluctuation, 70
 ambient temperature, 64, 70
 analog input signal, 21
 analog monitor, 10
 analog monitor gain, 86
 analog output signal, 21
 analog reference sample/hold selection, 52
 applying DC injection braking, 49
 approximate mass, 77
 automatic restart after momentary power loss, 42
 automatic retry attempts, 86
 auxiliary analog input selection, 54, 86

B

braking resistor unit, 10, 13, 14
 braking resistor unit overheat, 68
 braking resistor failure, 68
 braking torque, 70
 braking unit, 13, 14, 80

C

calibrating frequency meter or ammeter, 46
 carrier frequency, 12, 86
 closed-loop connector, 20
 coast to stop, 48
 coast to stop with timer, 49
 connection diagram, 10
 constant list, 84
 constant selection/initialization, 36
 constant setting error, 68
 constant operation by automatic fault reset, 45
 control characteristics, 70
 control circuit, 21
 control circuit fault, 67
 control circuit terminal, 21
 control circuit terminal signal, 29
 control circuit undervoltage, 66
 control method, 70
 control PC board, 64
 cooling fan, 64
 CPU A/D converter fault, 67
 Custom V/f pattern, 38

D

dB resistor overheat function, 87
 DC injection braking at start, 46
 DC injection braking current, 49, 87
 DC injection braking time at start, 8
 DC injection braking time at stop, 49, 87
 DC reactor, 11, 13, 14
 deceleration time, 84, 93
 deceleration to stop, 48
 derivative time, 88
 desired frequency agree signal, 56
 digital operator, 6, 27, 32
 digital operator connection fault detection, 89
 dimensions, 76
 display mode, 185

E

EEPROM fault, 67
 elapsed timer, 87
 elapsed timer selection, 87
 electronic thermal overload relay, 70
 elevation, 70
 emergency stop circuit, ii, 10
 enclosed wall-mounted type, 3, 70
 enclosure, 3
 energy saving control mode, 59
 energy saving gain K2, 59, 88
 energy saving selection, 88, 93
 energy saving tuning, 59
 energy saving voltage lower limit, 59, 88
 environment, 70
 excessive ripple in bus bar, 67
 external baseblock, 68
 external fault, 10, 21
 external fault from serial communication, 66

F

fault contact selection during automatic retry, 87
 fault diagnosis, 64, 66
 fault output signal, 10
 fault reset, 10, 21
 feedback calibration gain, 88
 feedback loss detection, 88
 feedback loss detection delay time, 88
 feedback loss detection level, 88
 forward run, 10
 frequency accuracy, 70
 frequency agree detection width selection, 89
 frequency agree signal, 56
 frequency control range, 70
 frequency detection, 44, 87
 frequency reference, 25, 85, 92
 frequency reference bias, 40, 86, 93
 frequency reference gain, 40, 86, 93
 frequency reference input, 21
 frequency reference lower limit, 41, 85
 frequency reference retention, 54, 86



INDEX

frequency reference setting method from digital operator, 84
 frequency reference upper limit, 41, 85
 frequency resolution, 70
 frequency setting power supply, 10
 frequency setting signal, 70
 function selection at LOCAL/REMOTE switching, 92
 FWD/REV run command, 92

G

ground fault, 70
 ground fault interrupter, 11
 ground terminal, ii, 11
 grounding, 12, 66

H

heatsink overheat, 66, 70
 heatsink overheating, 68
 humidity, 70

I

input phase loss detection delay time, 87
 input phase loss detection level, 87
 input voltage, 84
 instantaneous overcurrent, 70
 intake air temperature, 8
 integral time, 88
 Inverter capacity, 70
 Inverter kVA setting fault, 68
 Inverter motor, 57
 Inverter overheat pre-alarm, 68
 Inverter overload, 66
 Iron loss, 87

J

jog frequency, 85
 jump frequency, 44, 87
 jump frequency range, 87

K

kVA selection, 89

L

limit of integral value, 88
 line voltage, 26
 load short-circuit, 66
 LOCAL, 25
 LOCAL/REMOTE key function, 84
 LOCAL/REMOTE selection, 51
 location, 70
 loop test, 53

M

Magnetic Contactor, 11, 12
 magnetic starter, 12

main circuit, 11
 main circuit configuration, 15
 main circuit fault, 66
 main circuit power supply, iii, iv
 main circuit terminal, 13, 14
 main circuit undervoltage, 66
 master analog input selection, 53, 86
 master frequency reference, 10
 maximum applicable motor output, 3, 70
 maximum output frequency, 84
 maximum output voltage, 70
 maximum voltage, 84
 maximum voltage output frequency, 84
 MC fault, 66
 middle frequency voltage, 84
 middle output frequency, 84
 minimum baseblock time, 86
 minimum output frequency, 84
 minimum output frequency voltage, 84
 MEMOBUS BPS selection, 88
 MEMOBUS frequency reference unit, 61, 88
 MEMOBUS parity selection, 88
 MEMOBUS slave address, 61, 88
 MEMOBUS, stop method at communication error, 88
 MEMOBUS time over detection, 88
 MEMOBUS transmission error, 68
 MEMOBUS transmission fault, 67
 MEMOBUS transmission waiting, 68
 molded-case circuit breaker, iv, 11, 64
 momentary power loss, 70
 momentary power loss ridethrough method, 86
 monitor, 92
 monitor display, 92
 motor line to line resistance, 87
 motor no-load current, 89
 motor overload, 66
 motor overload detection, 57
 motor overload protection, 70
 motor overload protection selection, 57, 85
 motor rated current, 57, 85, 93
 motor rated voltage, 84, 93
 multi-function analog output, 10, 86
 multi-function contact input, 10
 multi-function contact input selection, 85, 86
 multi-function contact input setting error, 68
 multi-function contact output, 10
 multi-function contact output selection, 86
 multi-step speed reference, 21
 multi-step speed selection, 39
 multi-step speed setting, 10

N

nameplate, 2
 No. of V/f patterns, 70

O

OFF-delay timer, 87
 offset, 88

INDEX

S

ON-delay timer, 87
 open chassis type, 3, 70
 open phase, 69
 operating at low speed, 39
 operating coasting motor without trip, 45
 operating method for frequency reference loss detection, 54, 86
 operation mode selection, 60, 84
 output characteristics, 70
 output current, 92
 output frequency, 10, 92
 output frequency resolution, 70
 output lag filter time, 88
 output open-phase, 67
 output phase loss detection delay time, 88
 output phase loss detection level, 88
 output terminal, 12
 output voltage, 92
 OV during stop, 68
 overcurrent, 66
 overload, 70
 overload capacity, 70
 overload relay trip contact, 80
 overtorque detection, 66, 68
 overtorque detection function selection, 43, 87
 overtorque detection level, 43, 87
 overtorque detection time, 43, 87
 overvoltage, 66, 70

P

password, 84
 periodic inspection, 64
 phase advancing capacitor, 12
 photo-coupler insulation, 21
 PID selection, 88, 93
 power charge indication, 70
 power loss ridthrough time, 86
 power rotation, 84
 power supply, 70
 preset V/f pattern, 37
 PRGM mode, 93
 primary delay time constant 89
 proportional gain, 88
 protective function, 70

Q

quick-start LED, 32

R

rated input voltage and frequency, 70
 rated output current, 70
 rated output frequency, 70
 reducing motor noise or leakage current, 47
 REMOTE, 25
 reverse run, 10
 reverse run prohibit, 38, 84

s-curve selection, 87
 selecting stopping method, 48
 sequence common, 10
 sequence control input common, 21
 sequence input signal, 21
 sequence output signal, 21
 serial communication/control circuit terminal selection, 51
 shield sheath connection terminal, 10
 shielded wire, 11
 signal during running, 10
 simultaneous forward/reverse run commands, 68
 sine wave PWM, 70
 slip compensation gain, 89
 soft-start characteristics, 42
 specification, 70
 speed search command, 45
 speed search level, 86
 stall prevention, 70
 stall prevention during deceleration, 87
 stall prevention level during acceleration, 87
 stall prevention level during running, 87
 standard motor, 57
 step voltage of tuning, 60, 88
 stop key function, 84
 stopping method selection, 84, 85
 storage temperature, 70
 surge suppressor, 12
 switching frequency, 12

T

terminal function at 2-wire sequence selection, 51
 terminal function at 3-wire sequence selection, 51
 terminal screw, 17, 18, 19
 test run, 26, 27
 thermal overload relay, 12
 thermistor, 70
 time of average kW, 88
 timer function, 52
 torque compensation gain, 56, 87
 torque detection, 43
 twisted shielded wire, 17, 19
 twisted-pair shielded wire, 11, 22

U

undervoltage, 70
 undervoltage detection, 68
 UP/DOWN command, 52
 using analog input signals, 53
 using frequency meter or ammeter, 46
 using output signals, 55
 using sequence input signals, 50
 using two accel/decel times, 41



INDEX

V

V/f data setting error, 68
V/f pattern selection, 84, 93
V/f reduction level during speed search, 86
vibration, 70
voltage limit of tuning, 59, 88

W

wire size, 17, 18, 19
withstand voltage test, iii, 10

5580 Enterprise Parkway, Fort Myers, Florida 33905 ● Telephone (941) 693-7200 ● Fax (941) 693-2431
Web Address: <http://www.saftronics.com>