



[www.saftronics.com](http://www.saftronics.com)

# **AA1069 Dancer Control Card for DC Controllers**

**Saftronics, Inc.**

5580 Enterprise Pkwy., Ft. Myers, FL 33905

Telephone: (941) 693-7200

Fax: (941) 693-2431

[www.saftronics.com](http://www.saftronics.com)

DOC.NO. 027-1069

REV 2 09/01

## **SAFETY FIRST !**

### ***LETHAL VOLTAGES MAY BE PRESENT!***

PLEASE READ THIS INSTRUCTION MANUAL THOROUGHLY BEFORE ATTEMPTING ANY INSTALLATION, OPERATION, MAINTENANCE OR INSPECTION. FAILURE TO FOLLOW THE RECOMMENDED PROCEDURES OR CAUTIONS IN THIS MANUAL COULD RESULT IN INJURY TO PERSONNEL AND/OR DAMAGE TO EQUIPMENT.

## **CAUTION !**

1. CHECK THE NAME WRITTEN ON THE PRODUCTS AND INSURE THAT THE PROPER PART HAS BEEN RECEIVED.
2. THOROUGHLY INSPECT THE PART(S) FOR ANY DAMAGE DUE TO SHIPMENT OR HANDLING.
3. THE PART(S) MAY CONTAIN CMOS CHIPS AND CAN BE DAMAGED BY STATIC ELECTRICITY. HANDLING SHOULD BE IN ACCORDANCE WITH INDUSTRY STANDARDS.
4. BEFORE INSTALLING THE PART(S) TURN OFF ALL POWER TO THE EQUIPMENT. ***LETHAL VOLTAGES ARE PRESENT!***
5. DO NOT CONNECT OR DISCONNECT WIRING WHILE POWER IS **ON!**
6. FOLLOW GOOD STANDARD WIRING PRACTICES AND ANY APPLICABLE CODES THAT MAY APPLY.

**BEFORE ATTEMPTING ANY INSTALLATION PLEASE READ THIS MANUAL  
IN ITS' ENTIRETY**

**Description**

The **AA1069 Dancer Control Card** is a stand alone module that can be used to interface certain SAFTRONICS Drives (models specified later in this manual) with winder applications. It accepts a dancer operated potentiometer input while providing potentiometer excitation voltage and PID control to the drive. The card has a broad range of adjustments through the use of potentiometers and jumpers allowing optimum performance to be set in each application.

**Specifications**

The following table in conjunction with Fig.'s 1A and 2 will serve to outline the functions of the various board level components, range of adjustment, and terminations. The final settings will be determined by the actual application requirements.

**TABLE 1**

TERMINAL	DESCRIPTION	RANGE	ADJUSTMENT	INITIAL SETTING
1	Line Speed Ref.	80-100 V	RV1	Fully CCW
2	Input	10-20 V		
3	Dancer Potentiometer Pos. Supply Output	0- (+) 10V	AUTO	X
4	Dancer Potentiometer Neg. Supply Output	0- (-) 10V	AUTO	X
5	Integral Output	0-(+/-) 10 V	RV4	10 % CW
6	Dancer Position Input	0-(+/-) 10 V	EXTERNAL	MID. RANGE
7	GND	0 V	X	X
8	(-) 12 V Output	(-) 12 V	X	X
9	(+) 12 V Output	(+) 12 V	X	X
10	Enable	X	JUMP 8-10 TO RUN	
11	Proportional Output	0-(+/-) 10 V	RV6	10 % CW
12	Aux. Integral Input	(NOT USED)		X
13	Dancer Arm Input	0-(+/-) 10 V	EXTERNAL	MID. RANGE
14	L1 120 VAC 50/60H	120 VAC	X	X
15	L2 Input			
x	Minimum Adjustment	0-(+/-) 8 V	RV2	
x	Forcing or Derivative	0-0.5 Sec.	RV3	Fully CCW
x	Ramp or Integral Time	0-5.0 Sec.	RV5	10 % CW

**JUMPER SETTINGS**

L1	Line Speed Ref.	X	in for +	IN
L4	Input (Positive)	X	in for +	IN
L2	Line Speed Ref.	X	in for -	OUT
L3	Input (Negative)	X	in for -	OUT
L5	Integrator	X	X	IN
L6	Input	X	X	IN
L7	Aux. Integrator Input	(NOT USED)		X
P1	Integrator Output Polarity (Terminal 5)	(+/-) OUT (+) OUT only (-) OUT only	NO JUMPER jump + to center jump - to center	NO JUMPER

## **Installation**

**Before attempting any installation make sure that all power is turned off to the equipment being worked on.** As mentioned previously, the **AA1069** card is a stand alone module and can be installed in a variety of ways. It should be mounted in a protective enclosure, which is well ventilated. For mounting, there are four holes, as shown in Fig. 1B, for use with stand-offs, or the fast-track that is supplied may be used. The card requires a 120 VAC supply, which should be fused at 1.0 AMP. Referring to Fig.'s 1A and 2 make all external interconnections using shielded twisted wire. All wiring should be in accordance with good standard practices and any codes that may apply.

**Note: Some Model Drives require the use of the AA1081 Inverter / Buffer card with the AA1069 Module. Please refer to Appendix 1B for installation and set-up.**

## **Initial Set-up**

Since the **AA1069** card is designed to be used in a variety of winder applications, and with various SAFTRONICS drives, the initial settings suggested in Table 1 are for reference only. The final settings will be dictated by the particular application in which it is used. Referring to Table 1 and Fig.'s 1A and 2, proceed as follows for the initial set-up.

- 1 - **With the drive disconnected** and the **AA1069** installed as above, apply power to the card. Temporarily connect a jumper from terminal 8 ( (-) 12 V) and 10 (Enable). Adjust RV2 (Minimum Adjustment) to fully CCW (0V ). Then apply the appropriate full scale LINE SPEED REFERENCE voltage, between terminal 1 or 2 and terminal 7 GND. i.e., the voltage that would represent maximum line speed. Ensure that the proper jumpers are in place, L1 and L4 for a positive reference, or L2 and L3 for negative.
- 2 - Connect a voltmeter to terminal 3 ( Dancer + Supply) and terminal 7(GND) then adjust RV1(Speed Adj.) for +10 V. Check that terminal 4 (Dancer (-) Supply) is (-) 10 V. Next check that the slider on both the Dancer (terminal 13) and Dancer Position (terminal 6) potentiometers adjust from (+/-) 10 V throughout their range with 0 V in mid-position.

**NOTE: the Dancer slider should read 0V when in it's mechanical neutral position. Also, the polarity of the Dancer input at terminal 13 must be in a direction as to provide the proper feedback.**

- 3 - Ensure that jumpers L5 and L6 are in, and set the Dancer slider to it's neutral position (0 V) (or disconnect it) . Adjust the Position Input potentiometer for (-) 10 V at terminal 6. Connect the voltmeter to terminal 11 (Proportional Output) and adjust RV6 to obtain +1 V output or approximately 10% of the Dancer input.

- 4 - Adjust RV5 (Integral Time) to approximately 10% CW. This will set an integration time of 0.5 SEC. Next, adjust RV4, (Integral Output), to approximately 10% CCW which will provide a 1 V maximum integration error to be summed with the proportional error at terminals 5 and 11. On the **AA1069** board, remove the jumper **J1**, if installed. This will allow the output from the integrator to be bi-polar (+/-).

**NOTE: In some applications, it is desirable to have a + or – output. This is set by the jumper position on P1.**

- 5 - Connect the voltmeter to terminal 5, (Integral Output), and momentarily remove the jumper from terminal 10 (Enable). This will reset the integrator and terminal 5 should read 0 V. Reconnect the jumper and note that the voltage on terminal 5 should ramp up to approximately +1 V in 0.5 SEC.
- 6 - Adjust RV3 (Derivative Control) to fully CCW (0 SEC). There is no pre-set for this control and its setting is application dependent.
- 7 - The Minimum Adjustment potentiometer RV2 provides a minimum excitation voltage to the Dancer potentiometer when there is no Line Speed Reference, such as on start-up. This setting is also application dependent and is normally set so that a neutral Dancer position is maintained. It is initially set fully CCW (0 V).

In summary, using the initial settings, a full range change in the mechanical Dancer position will provide a (+/-) 10% proportional change in the **set** Line Speed. The Integral output, which is summed with the proportional change, will be limited to a maximum of 1 V, with an integration time of 0.5 SEC. The derivative time is set to 0 SEC by RV3, and the minimum Dancer excitation voltage is set to fully CCW (0 V) by RV2. The neutral Dancer operating position can be set by the Dancer position potentiometer. However, it is recommended that the mechanical Dancer neutral position be set in the middle of the mechanical range so that full range control may be realized.

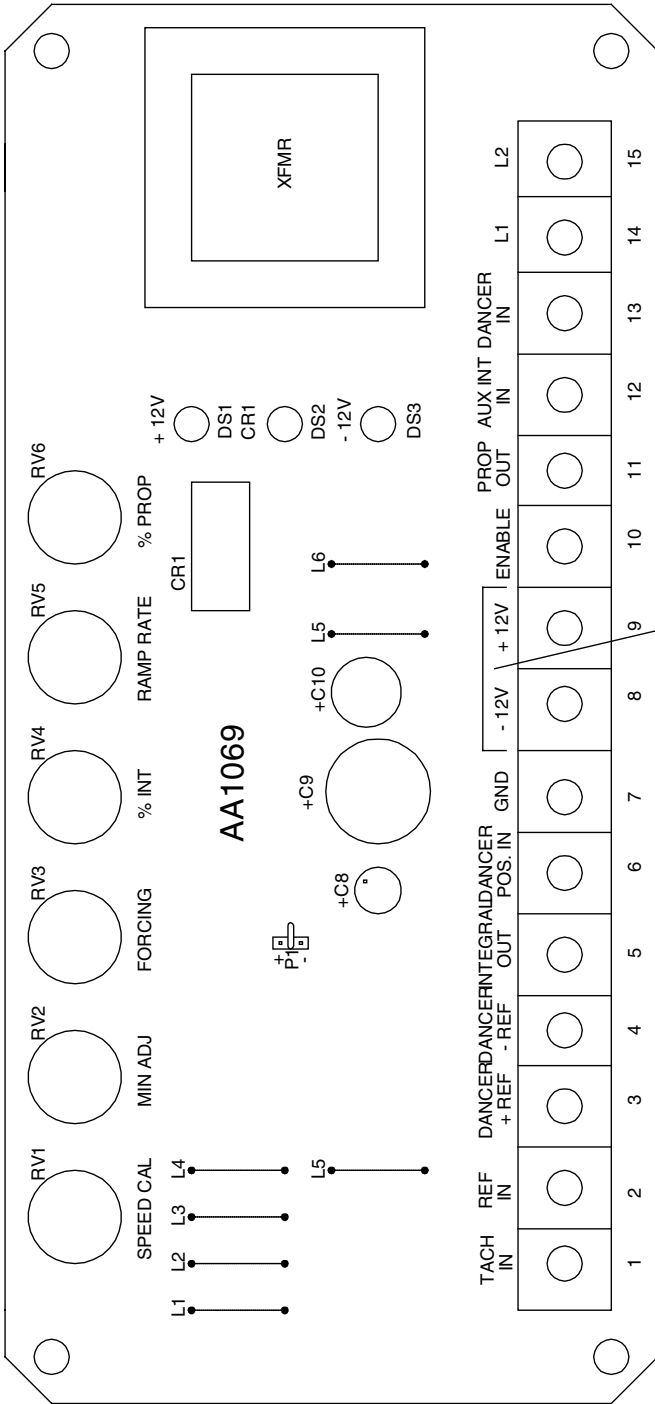

**FIGURE 1A - AA1069 DANCER CONTROL CARD**  
**PAGE 6**

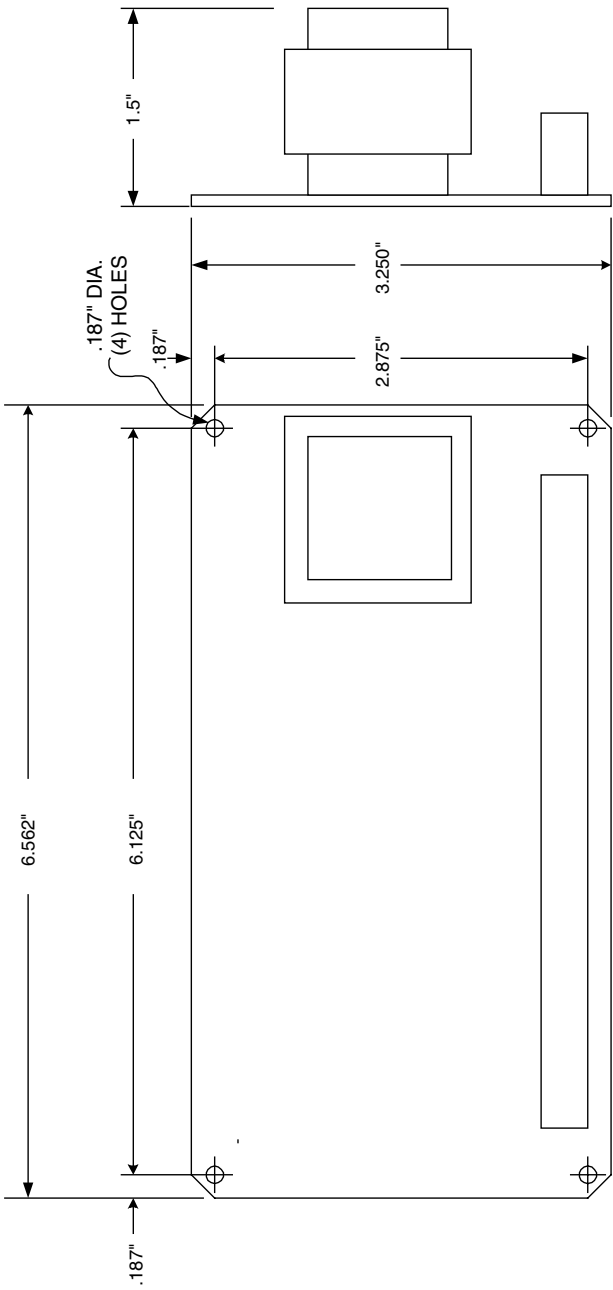
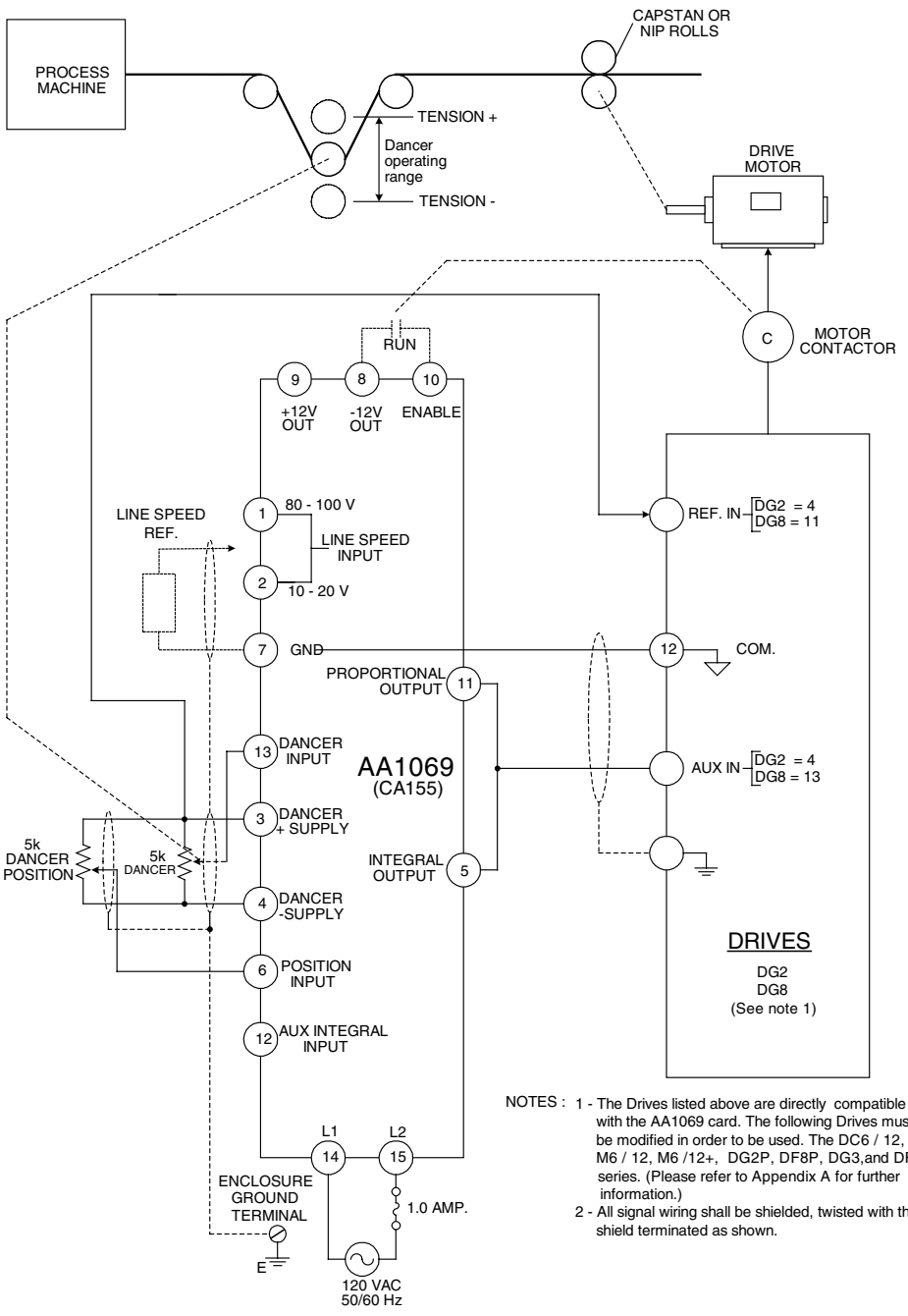

FIGURE 1B - AA1069 DANCER CONTROL CARD DIMENSIONS



NOTES : 1 - The Drives listed above are directly compatible with the AA1069 card. The following Drives must be modified in order to be used. The DC6 / 12, M6 / 12, M6 /12+, DG2P, DF8P, DG3, and DF9 series. (Please refer to Appendix A for further information.)  
 2 - All signal wiring shall be shielded, twisted with the shield terminated as shown.

FIGURE 2 - AA1069 INTERCONNECTING DIAGRAM

## Appendix 1A

### DC6/12

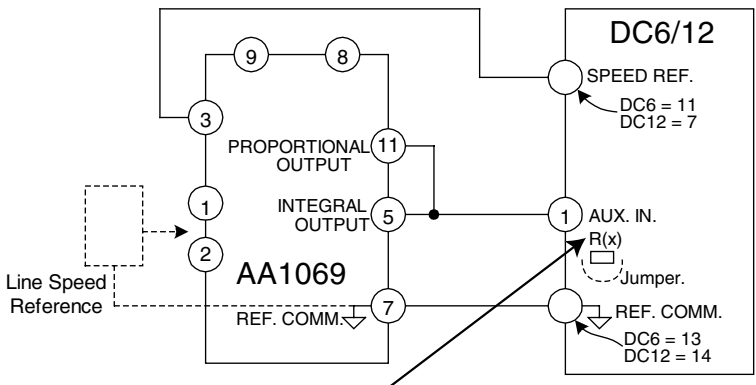

**NOTE:**  
 On the DC6, M650 Control Board, R222 must be removed and replaced by a jumper. On the DC12, M1200 Control Board R160 must be removed and replaced by a jumper.

### M6/12

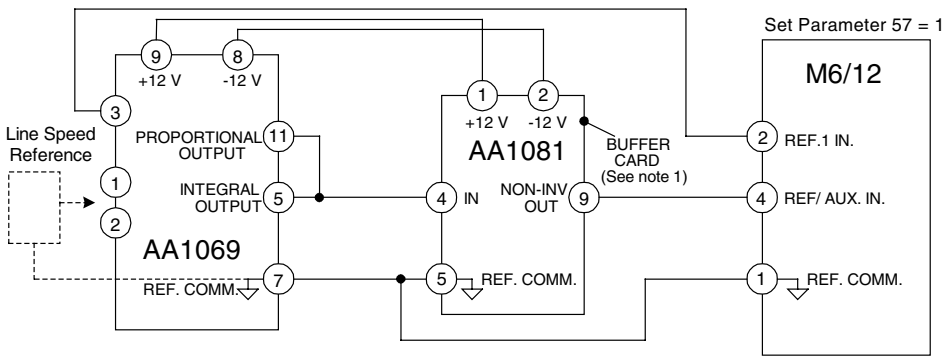

## M6/12+

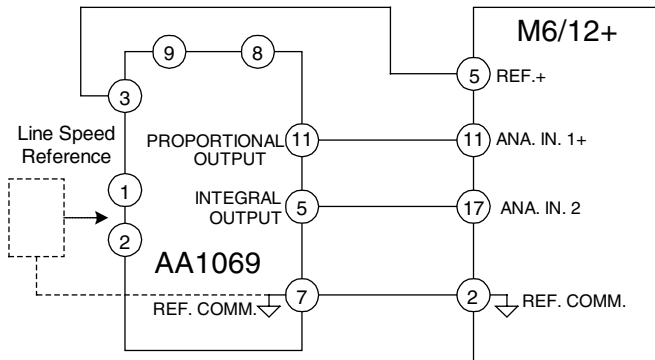

Set Parameter C120 = 1 (Prop.)  
Set Parameter C120 = 1 (Int.)

---

## Appendix 2A

### DG2P

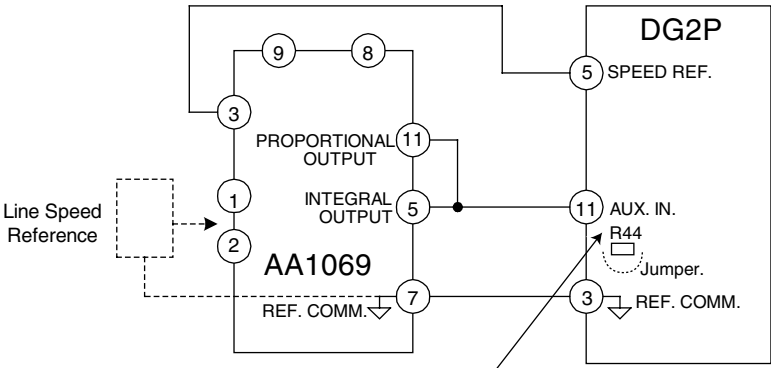

NOTE:  
On the AA1128 Control Board, R44 must be removed and replaced by a jumper. (R44 is a surface mounted device and requires extreme care when removing.)

## **DF8P**

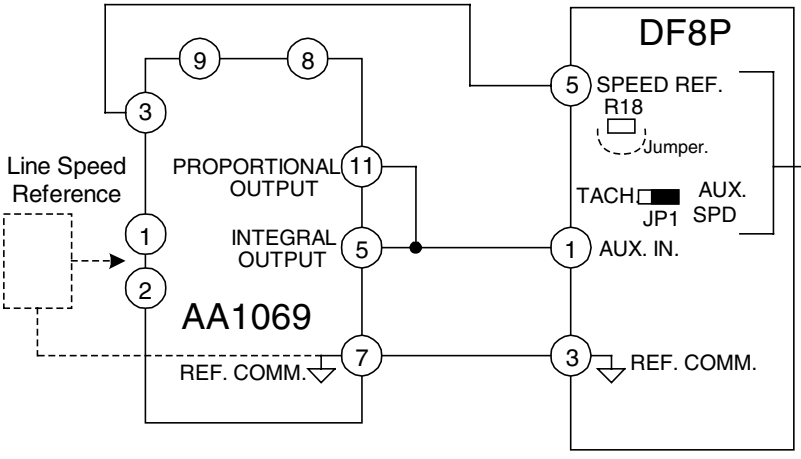

**NOTES:**

- 1 - On the AA1152 Control Board, R18 must be removed and replaced by a jumper. (R18 is a surface mounted device and requires extreme care when removing.)
- 2 - Place jumper JP1 in the AUX. SPD. position. (Tachometer feed-back can not be used when the AA1069 Dancerboard is used with the DF8P Drive.)

## **DG3 & DF9 Series**

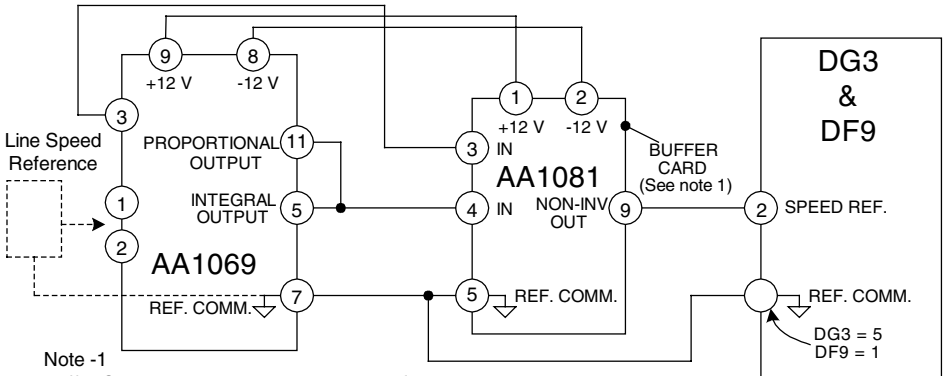

Note -1  
Buffer Card AA1081 is required when interfacing to the DG3 & DF9 and must be purchased separately (See Appendix 1B).

## Appendix 1B

### AA1081 INVERTER / BUFFER SYSTEMS CARD

#### Description

The **AA1081 INVERTER / BUFFER SYSTEMS CARD** is a stand alone module that is designed to provide analog signal conditioning in a variety of motor control applications. It provides signal buffering, signal Inverting and the ability to sum (2) input signals. It has an offset as well as a gain adjustment.

#### Specifications

Power Requirements	-	(+ / -) 12 VDC @ 30 mA (max.)
Maximum Output Voltage	-	(+ / -) 10 VDC
Maximum Input Voltage	-	(+ / -) 10 VDC
Input Resistance	-	10 K (inverting and non-inverting)
Minimum Load Resistance	-	1 K
Offset Adjustment Range	-	(+ / -) 0 – 2.5 V @ G = 1 (factory set for 0 V)
Gain Adjustment Range	-	G = 0.5 - 10 (factory set for 1)

#### Installation

**Before attempting any installation make sure that all power is turned off to the equipment being worked on.** The AA1081 card is a stand alone module and can be mounted in a variety of ways. It should be mounted in a protective enclosure which is well ventilated. Four mounting holes are provided as shown in Fig. 1B for use with stand-offs. Referring to Fig. 1A, make all external connections using shielded twisted wire. **All wiring should be in accordance with good standard practices and any codes that may apply.**

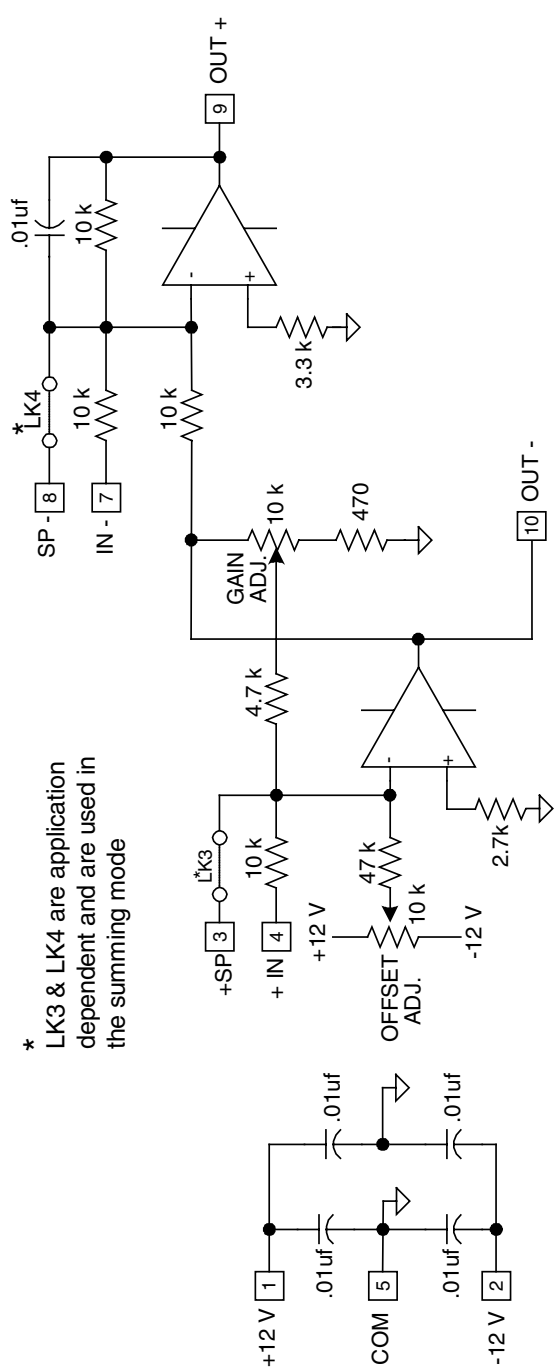

AA1081 SCHEMATIC DIAGRAM

## Appendix 2B

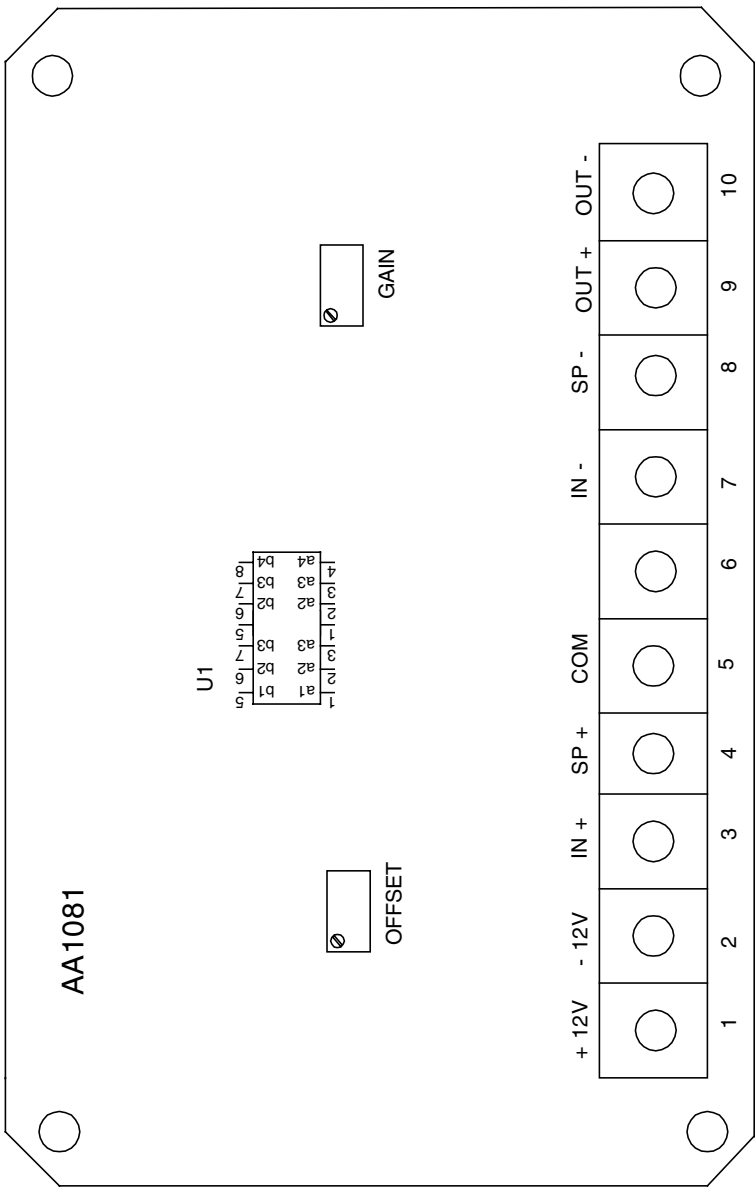

FIGURE 1A - AA1081 INVERTER/BUFFER SYSTEMS CARD

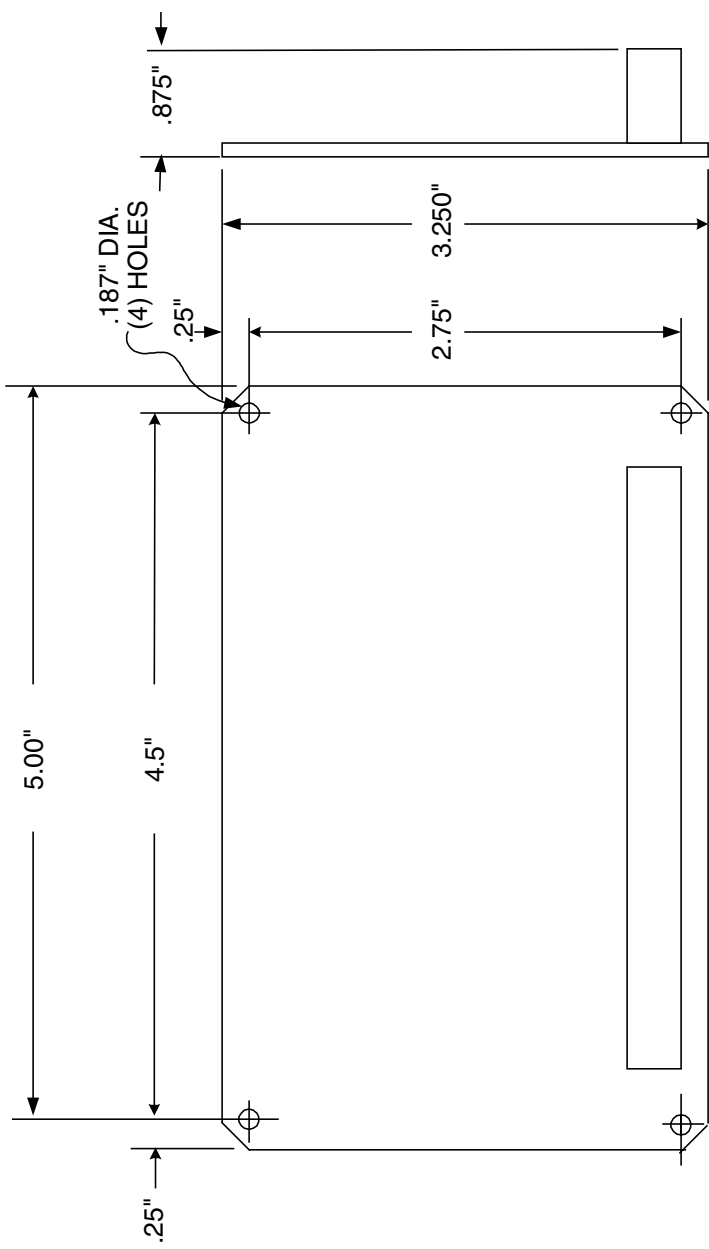

FIGURE 1B - AA1081 DIMENSIONS

## **WARNING!**

*Saftronics* manufactures component parts that can be used in a wide variety of industrial applications. The selection and application of *Saftronics* products remains the responsibility of the equipment designer or end user. *Saftronics* accepts no responsibility for how it's products may be incorporated into the final design.

Under no circumstances should any *Saftronics* product be incorporated into any product or design as the exclusive or sole safety control. Without exception, all controls should be designed to dynamically fault detect and fail safe under all circumstances. All products designed to incorporate a component part manufactured by *Saftronics*, must be supplied to the end user with appropriate warnings and instructions as to the safe use and operation. Any warnings provided by *Saftronics* must be passed through to the end user.

*Saftronics* offers an express warranty only as to the quality of it's products to conform to the catalog specifications. **NO OTHER WARRANTY, EXPRESS OR IMPLIED, IS OFFERED.** *Saftronics* assumes no liability for any personal injury, property damage, losses or claims, arising out of the mis-application of it's products.