



INSTRUCTION MANUAL

DOCUMENT NO. 027-0186
Rev. 1.01 Nov. 1, 2004

***Speed Command Reversing
Option Card
for the CV10***

Part Number 100 - 0186 - 01

Saftronics, Inc.

5580 Enterprise Pkwy

Ft. Myers, FL 33905

Tel. (239) 693 - 7200

Fax (239) 639 - 2431

www.saftronics.com

LETHAL VOLTAGES MAY BE PRESENT

PLEASE READ THIS MANUAL THOROUGHLY BEFORE ATTEMPTING ANY INSTALLATION, OPERATION, MAINTENANCE, OR INSPECTION. FAILURE TO FOLLOW THE RECOMMENDED PROCEDURES OR CAUTIONS IN THIS MANUAL COULD RESULT IN INJURY TO PERSONNEL AND / OR DAMAGE TO THE EQUIPMENT.

CAUTION

- 1 – CHECK THE NAME WRITTEN ON THE PRODUCT AND INSURE THAT THE PROPER PART HAS BEEN RECEIVED.
- 2 – THOROUGHLY INSPECT THE PART(S) FOR ANY DAMAGE DUE TO SHIPMENT OR HANDLING.
- 3 - THE PART(S) MAY CONTAIN CMOS CHIPS AND CAN BE DAMGED BY STATIC ELECTRICITY. HANDLING SHOULD BE IN ACCORDANCE WITH INDUSTRY STANDARDS.
- 4 - BEFORE INSTALLING THE PART(S) TURN OFF ALL POWER TO THE EQUIPMENT AND INSURE THE CHARGE INDICATOR LAMP ON THE INVERTER IS **OFF**. **LETHAL VOLTAGES ARE PRESENT**
- 5 - DO NOT CONNECT OR DISCONNECT WIRING WHILE POWER IS **ON!**
- 6 - FOLLOW GOOD STANDARD WIRING PRACTICES AND ANY APPLICABLE CODES THAT MAY APPLY.

CV10 Speed Command Reversing Option

P/N 100 – 0186 – 01

Description

The **100 – 0186 – 01** Option Card is designed for use with the **Safronics CV10** Inverter series. It provides forward and reverse speed control by following an external bi-polar input speed command signal of +10VDC to –10VDC. This signal from the users' equipment, such as a PLC or control transducer, is converted into a usable command for the **CV10** by the option card, controlling speed and direction.

Specifications

Input Control Voltage - + 10VDC to –10VDC
Input Resistance - 680 ohm

Installation

Please read this manual in its' entirety before attempting any installation!

Turn off all power to the equipment being worked on. Referring to **Fig.1**, the option card is mounted inside the inverter directly to the **CV10** control board. Referring to the **CV10** Manual, remove the terminal cover of the **CV10** and remove the (2) assembly screws and washers from the front of the **CV10** control board. Next, slide the hardpin connections **J1**, of the option card, into the **CV10** control board terminals of **TM2**, as shown. Align the assembly holes, and secure with the assembly screws. **Important!** Tighten the **TM2** terminal screws of the **CV10** so that the hardpins of **J1** on the option card are secure. Connect the **W1** lead from the option card, to the **S2** terminal of **TM2** on the **CV10**, and secure.

Referring to **Fig. 3**, make the control voltage wiring connections to the option card terminal block **TB1**, through the conduit openings of the **CV10**, observing good standard practices, and all applicable codes. Set **SW1** to the **NPN** position, then recheck all wiring and settings. Replace the cover on the **CV10**, then power up the inverter. Following the instructions in the **CV10** Manual, enter the programming mode and set parameter **1 – 01 = 0001 (Run / Stop – Forward / Reverse)**.

The installation is now complete.

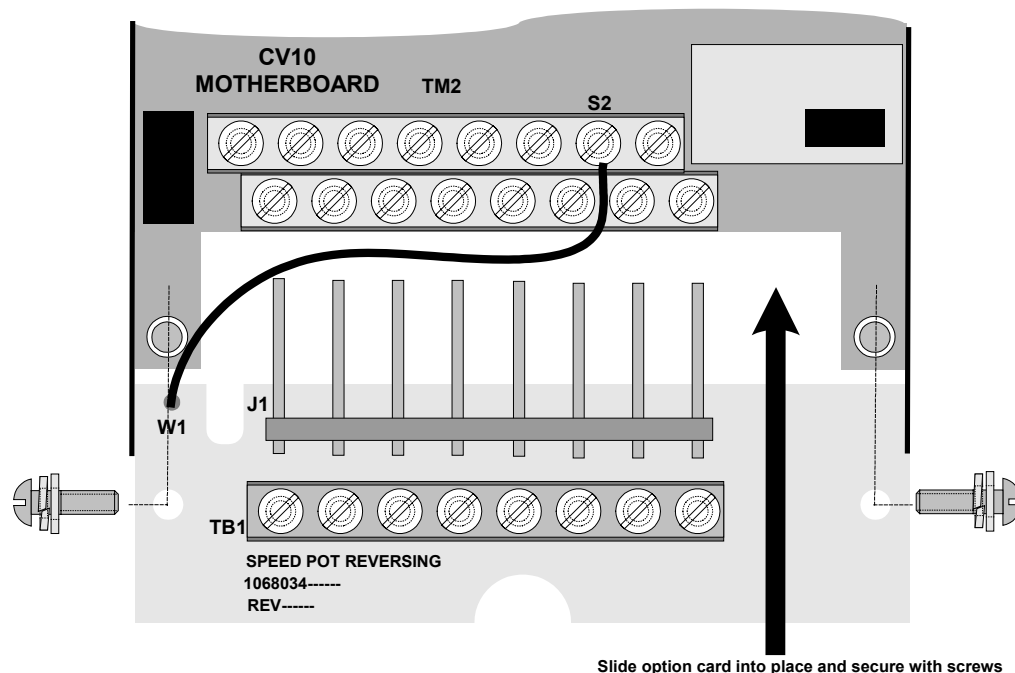

Fig. 1 Product Appearance and Assembly

Terminal Connection on Option Card

The wire size range that the option card connection terminal(s) can accommodate, is AWG: 16-26. Referring to the figure below, strip the wire back about 1/4 " (6 mm) and make the connection to the terminals by inserting wire into the upper side of the metal bracket on the terminal block, and tighten the screw.

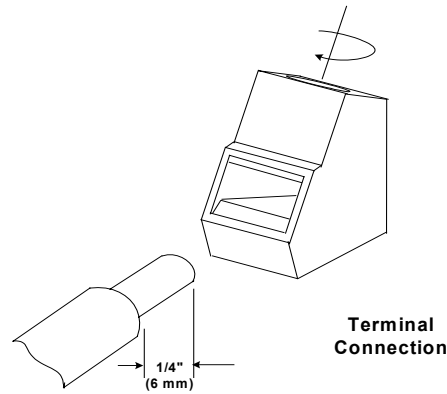
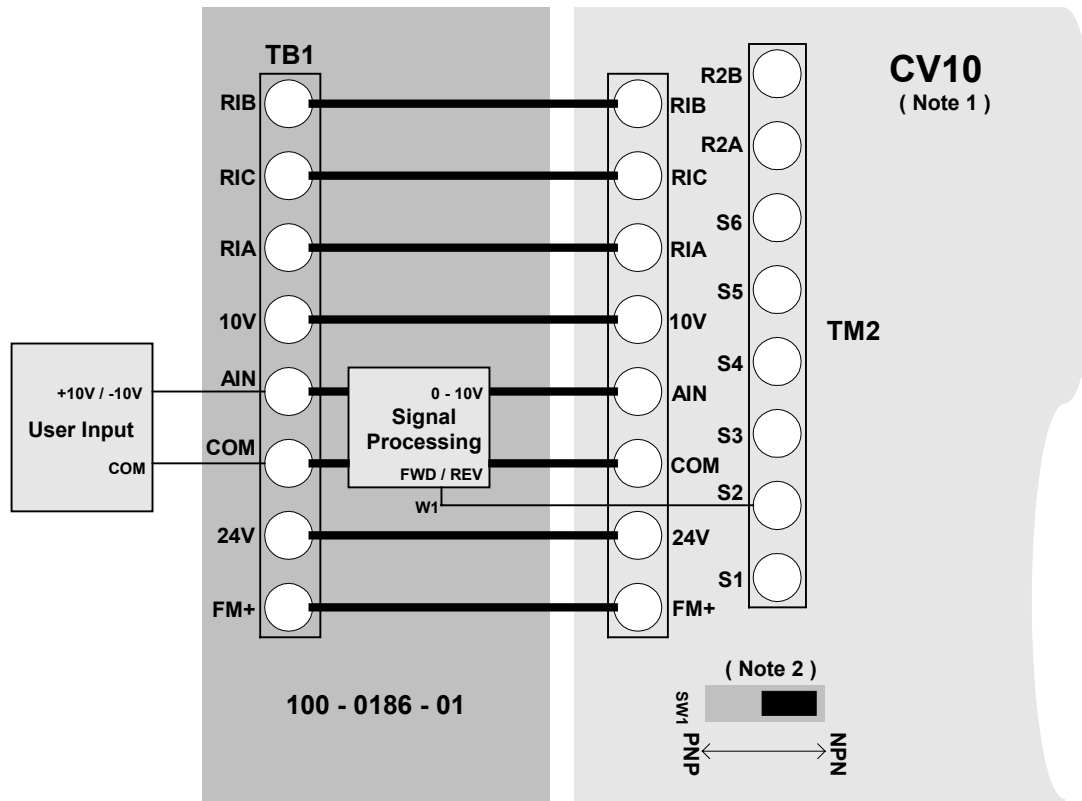

Fig. 2



- NOTES : 1 - Set drive parameter 1- 01 = 0001 (Run / Stop - Forward / Reverse)
 2 - Set Switch SW1 to NPN.

Fig. 3 100 - 0186 - 01 Interconnecting Diagram

WARNING!

Saftronics manufactures component parts that can be used in a wide variety of industrial applications. The selection and application of *Saftronics* products remains the responsibility of the equipment designer or end user. *Saftronics* accepts no responsibility for how its products may be incorporated into the final design.

Under no circumstances should any *Saftronics* product be incorporated into any product or design as the exclusive or sole safety control. Without exception, all controls should be designed to dynamically fault detect and fail safe under all circumstances. All products designed to incorporate a component part manufactured by *Saftronics*, must be supplied to the end user with appropriate warnings and instructions as to the safe use and operation. Any warnings provided by *Saftronics* must be passed through to the end user.

Saftronics offers an express warranty only as to the quality of its' products to conform to the catalog specifications. NO OTHER WARRANTY, EXPRESS OR IMPLIED, IS OFFERED. *Saftronics* assumes no liability for any personal injury, property damage, losses or claims, arising out of the misapplication of its' products.