



SDBU

Saftronics Dynamic Brake Unit

INSTRUCTION MANUAL

CAUTION

Equipment is at possible lethal DC voltage when AC power is connected to the inverter. Stopping the Inverter does not remove voltage from the dynamic brake unit. Power must be disconnected from the connected inverter and both DC bus charge light and the SDBU power on LED must be completely out before touching any terminals, or components.

Saftronics, Inc.
5580 Enterprise Parkway
Fort Myers, FL 33905
Phone: (239) 693-7200
Fax: (239) 693-2431
© Copyright Saftronics, Inc. 2002

Part Number 027-0010
REV #3 07/2002

TABLE OF CONTENTS

SECTION 1.0 OVERVIEW	3
SECTION 2.0 SPECIFICATIONS	3
2.1 Electrical	3
Table 1 SDBU Ratings	3
2.2 Environmental	4
SECTION 3.0 INSTALLATION	4
3.1 General	4
3.2 Wiring	4
Table 2 Wire Sizing	5
3.3 Connections	5
Table 3 Terminal Description	5
3.4 Settings	5
SECTION 4.0 START-UP	5
4.1 LED functions	6
Table 4 Jumper Settings	6
SECTION 5.0 TROUBLE SHOOTING	7
Table 5 Trouble Shooting	7
SECTION 6.0 SAFTRONICS INVERTERS	7
Figure 1 SDBU Panel Jumpers and Terminations	8
Figure 2 SDBU Single Unit Connections	9
Figure 3 SDBU Parallel Connections	10
Table 6 GP10 CT & VG10 Inverter Braking Unit and Resistor Table	11
Table 7 AD10 Inverter Braking Unit and Resistor Table	12
Table 8 VG5 Inverter Braking Unit and Resistor Table	13
SECTION 7.0 SDBU DIMENSIONAL OUTLINE	15
SECTION 8.0 WARRANTY	16

1.0 OVERVIEW

Dynamic braking in general enables high inertia type loads to be decelerated more rapidly to zero speed, and also allows the inverter to have tight speed control on overhauling loads.

The Saftronics **SDBU Inverter Dynamic Brake Unit** can be used in conjunction with any AC inverter. The unit is designed to continuously monitor the Inverter DC bus voltage and when it exceeds a predetermined level (depending on supply voltage) the brake unit IGBT (Insulated Gate Bipolar Transistor) is turned on, dissipating the excess energy through an external resistor.

The **SDBU** is available in three different voltage classes, 200V, 400V, and 575V and three different continuous current ratings, 30A and 80A for the 200V and 400V classes, 30 A and 60A for the 575V class. The **SDBU's** can be set up for multiple unit operation using the **master / slave** mode, to achieve the necessary power rating for a given horsepower.

2.0 SPECIFICATIONS

2.1 ELECTRICAL

TABLE 1 Standard Voltage SDBU Ratings

VOLTAGE CLASS	JUMPER SELECTABLE AC INPUT VOLTAGES	IGTB TURN ON DC BUS VOLTAGE	SDBU P/N	CON'T CURRENT	WATT LOSS
200V	230V	354V	909-0001	30A	21
			909-0002	80A	56
400V	460V	740V	909-0003	30A	21
			909-0004	80A	56
575V	575V	885V	909-0005	30A	21
			909-0006	60A	42

Note: See TABLE 4, Pg. 4 for non-standard input A-C voltages

- **Service Factor** - 1.0
- **Regenerative Torque** - 125%
- **Fault Relay Contact** - (1) NO or NC (jumper selectable)
8 A @ 250 VAC
- **Led Indicators** - Power On (Green)
Fault (Red)
Brake On (Green)
- **DB Turn On Level Adj.** - Sets the IGBT turn on DC Bus voltage level
(THIS IS FACTORY PRE-SET)
- **Isolated Input** - 24 VDC @ 20 mA
Allows controlling of the SDBU from a remote input

2.2 ENVIRONMENTAL

- Ambient Temp. - 0° - 55°C (+32° - 131°F) De-rate 1.5% / ° C (0.83% / °F)
- Altitude - 1000m (3300 ft.) De-rate 1%/100m (1%/300ft.)

3.0 INSTALLATION

3.1 GENERAL

The SDBU must be installed in an area where the ambient air is free from steam, flammable or combustible vapors, and corrosive gases. The ambient temperature and altitude must be within the environmental specifications.

Ensure that there is adequate ventilation around the enclosure and that there are no heat sources in close proximity. Ensure that the mounting of the SDBU is free from vibration.

3.2 WIRING

The SDBU is to be installed in accordance with the NEC and any other local electrical codes that may apply. See TABLE 2 for wire sizes

The chassis must be connected to earth ground according to code.

Separate all signal wiring from the power wiring to minimize electrical noise problems

The following diagram shows wiring distance guidelines.

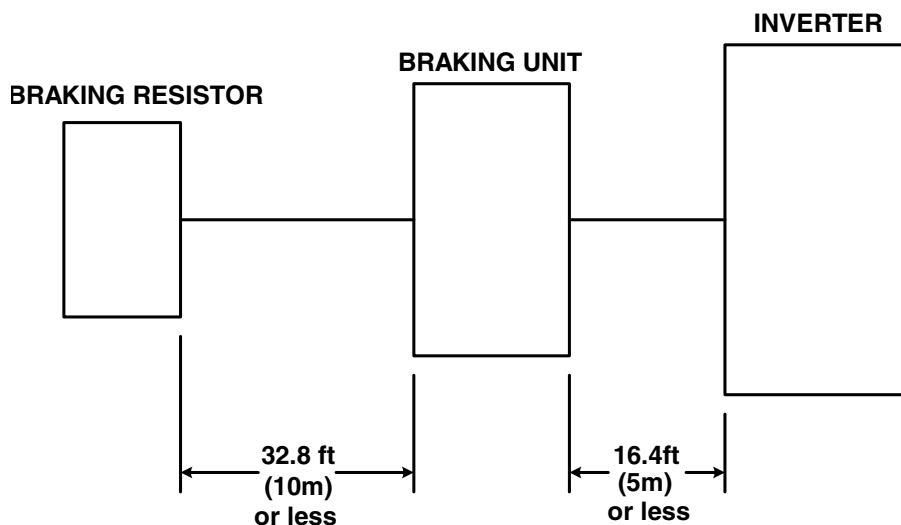

TABLE 2 Wire Sizing

HORSEPOWER & DUTY		CIRCUIT	WIRE SIZE
230 VAC	460 / 575 VAC		
1 – 50 HP 10% DUTY	1 – 75 HP 10% DUTY	POWER	10 – 12 AWG
1 – 30 HP 30% DUTY	1 – 40 HP 30% DUTY	CONTROL	14 – 18 AWG
60 – 100 HP 10% DUTY	100 – 150 HP 10% DUTY	POWER	8 – 10 AWG
40 – 75 HP 30% DUTY	50 – 75 HP 30% DUTY	CONTROL	14 – 18 AWG
100 HP 30% DUTY	200 – 250 HP 10% DUTY	POWER	6 – 8 AWG
	100 – 250 HP 30% DUTY	CONTROL	14 – 18 AWG

3.3 CONNECTIONS

Referring to FIG. 1, Pg. 6 (Panel Jumpers and Terminations) and TABLE 3 (Terminal Description), wire the SDBU(s) accordingly. **In the case where the SDBU(s) are being used with the SAFTRONICS line of Inverters (GP10, VG10, AD10, or VG5 series), refer to FIG. 2, Pg. 7 for single unit or FIG. 3, Pg. 8 for parallel units connections. In addition, refer to the Braking Unit and Resistor Table for each series for more specific information on resistor values and duty cycles for a given horsepower and input voltage.**

TABLE 3 Terminal Description

TERMINAL NUMBER	DESCRIPTION
N (DC-)	Negative Power Connection from Inverter DC bus.
P (DC+)	Positive Power Connection from Inverter DC bus.
G	Ground
Po (1)	Output power to DB resistor
B (2)	Output power to DB resistor
1	Slave input (+)
2	Slave input (-)
3	Fault output contact NO or NC (selectable)
4	Fault output contact NO or NC (selectable)
5	Master output (+)
6	Master output (-)
7	Isolated input (+)
8	Isolated input (-)
9	120 VAC input for fan and brake enable.
10	120 VAC input for fan and brake enable.

3.4 SETTINGS

Referring to TABLE 4 (Jumper Settings) and FIG. 1 (SDBU Panel Jumpers and terminations) configure the SDBU in accordance with the application requirements. In TABLE 4 note the CAUTION in configuring the Brake Enable Activation Jumper (JP6). All of the jumpers are accessible through the front cover and the installation can be completed without any disassembly.

The DB Turn On Level Adj potentiometer is FACTORY pre-set and should not be altered.

4.0 START-UP

Before applying power to the Inverter re-check all wiring and settings to insure proper performance. After power up verify that the power on LED (green) is ON. Run the Inverter and verify that the required deceleration characteristics can be obtained. The DB ON LED (green) should be ON when decelerating.

4.1 LED FUNCTIONS

The LED functions are as follows:

- Power On (green) - Verifies DC voltage is applied to terminals N (DC -) & P (DC +)
- Brake On (green) - On when the SDBU is braking
- Fault (red) - Turns on when there is a heatsink overtemp, shorted IGBT, or no resistor connected.

TABLE 4 Jumper Settings

FACTORY DEFAULT JUMPER SETTINGS														
SDBU P/N	CON'T AMPS	AC LINE VOLTAGE	BUS DC TURN ON VOLTAGE	LINE VOLTAGE INPUT					BRALE ENABLE JP6		MAST / SLAVE JP7		FAULT CONT JP8	
				JP1	JP2	JP3	JP4	JP5	W / FAN	WO / FAN	MAST	SLAVE	NO	NC
909-0001	30	230	354					X		OFF	X			X
909-0002	80	230	354					X	ON		X			X
909-0003	30	460	740					X		OFF	X			X
909-0004	80	460	740					X	ON		X			X
909-0005	30	575	885					X		OFF	X			X
909-0006	60	575	885					X	ON		X			X

NON - DEFAULT SETTINGS FOR OTHER LINE VOLTAGE INPUTS				JP1	JP2	JP3	JP4	JP5
SDBU P/N	CON'T AMPS	AC LINE VOLTAGE	BUS DC TURN ON VOLTAGE					
909-0003	30	380	614	X				
909-0004	80	380	614	X				
909-0001	30	200	308		X			
909-0002	80	200	308		X			
909-0001	30	208	322			X		
909-0002	80	208	322			X		
909-0001	30	220	340				X	
909-0002	80	220	340				X	
909-0003	30	400	644		X			
909-0004	80	400	644		X			
909-0003	30	415	673			X		
909-0004	80	415	673			X		
909-0003	30	440	712				X	
909-0004	80	440	712				X	
909-0005	30	500	770		X			
909-0006	60	500	770		X			

CAUTION !

If this function is turned OFF and the Inverter is not running, but power is applied, the bus voltage could reach a value to to turn on the SDBU 100% of the time causing the DB resistor(s) to be damaged and / or result in fire. See fig. 2 or 3 for use of an overtemp. switch and input contactor.

JUMPER DESCRIPTION

- JP1 - JP5 Sets the SDBU for the Inverter line voltage
- JP6 Sets the brake function ON or OFF with 120 VAC applied to terminals 9 & 10
ON - SDBU enabled when 120 VAC is applied. When removed the SDBU is disabled.
OFF - Function is disabled (*see caution*)
- JP7 Sets the Master / Slave configuration for multiple SBDUs'
- JP8 Selects the Fault contact to be NC or NO at Terminals 3 & 4

5.0 TROUBLESHOOTING

If the SDBU is not functioning properly refer to TABLE 5 (Troubleshooting) or consult factory for further guidance.

TABLE 5 Troubleshooting

FAULT	REASON	ACTION
Braking resistor over temperature switch activates when the SDBU is not decelerating.	The SDBU IGBT is shorted. Improper SDBU power supply voltage selection jumper setting. (Power supply voltage is greater than the jumper selection.)	Replace SDBU Select correct jumper setting.
Inverter trips overvoltage "OV"	Insufficient braking resistor capacity. Improper wiring SDBU Fault	Increase deceleration time or decrease resistor value Δ . Check and correct Replace the SDBU
Braking resistor over temperature switch sometimes trips.	Braking resistance too low or duty cycle too high.	Check the SDBU DB Resistor and duty cycle.
Fault relay energized and fault LED is on.	SDBU over temperature Open Resistor No resistor connected IGBT failure	Check duty cycle and/or high ambient temperature. Check fan on 60 & 80 A units. Check resistor and connections Connect resistor Replace SDBU

6.0 SAFTRONICS INVERTERS

Although TABLES 6 through 9 show detailed information for SAFTRONICS' Inverters, much of the data pertains to Inverters in general. The sections showing where a braking module (SDBU) is not required is where the braking unit is built into the SAFTRONICS Inverter.

Δ CAUTION !

IF A SMALLER RESISTANCE THAN THE ABSOLUTE MINIMUM VALUE SHOWN IN THE TABLES IS USED, PERMANENT DAMAGE TO THE SDBU MAY RESULT.

FIGURE 2 SDBU Single Unit Connections

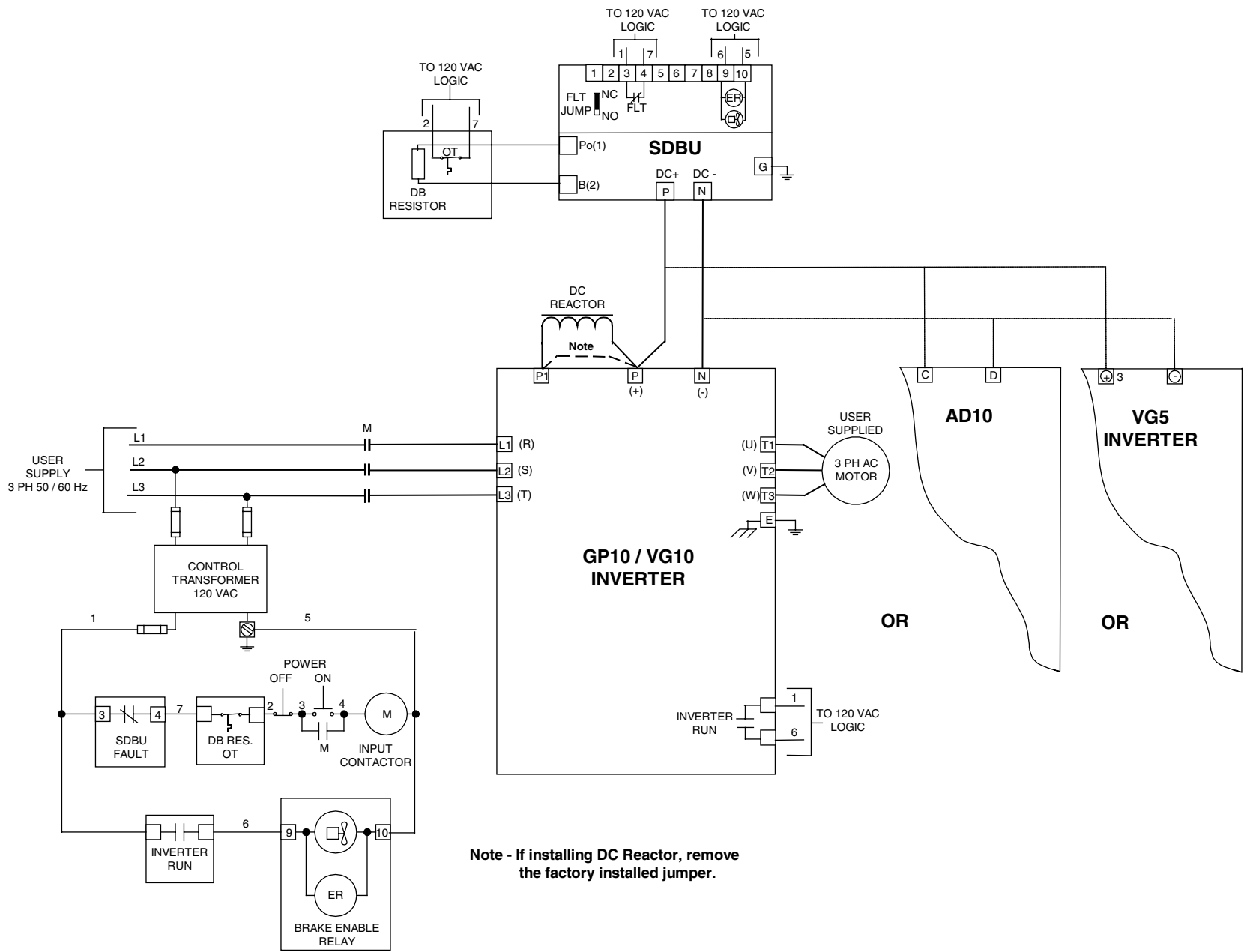
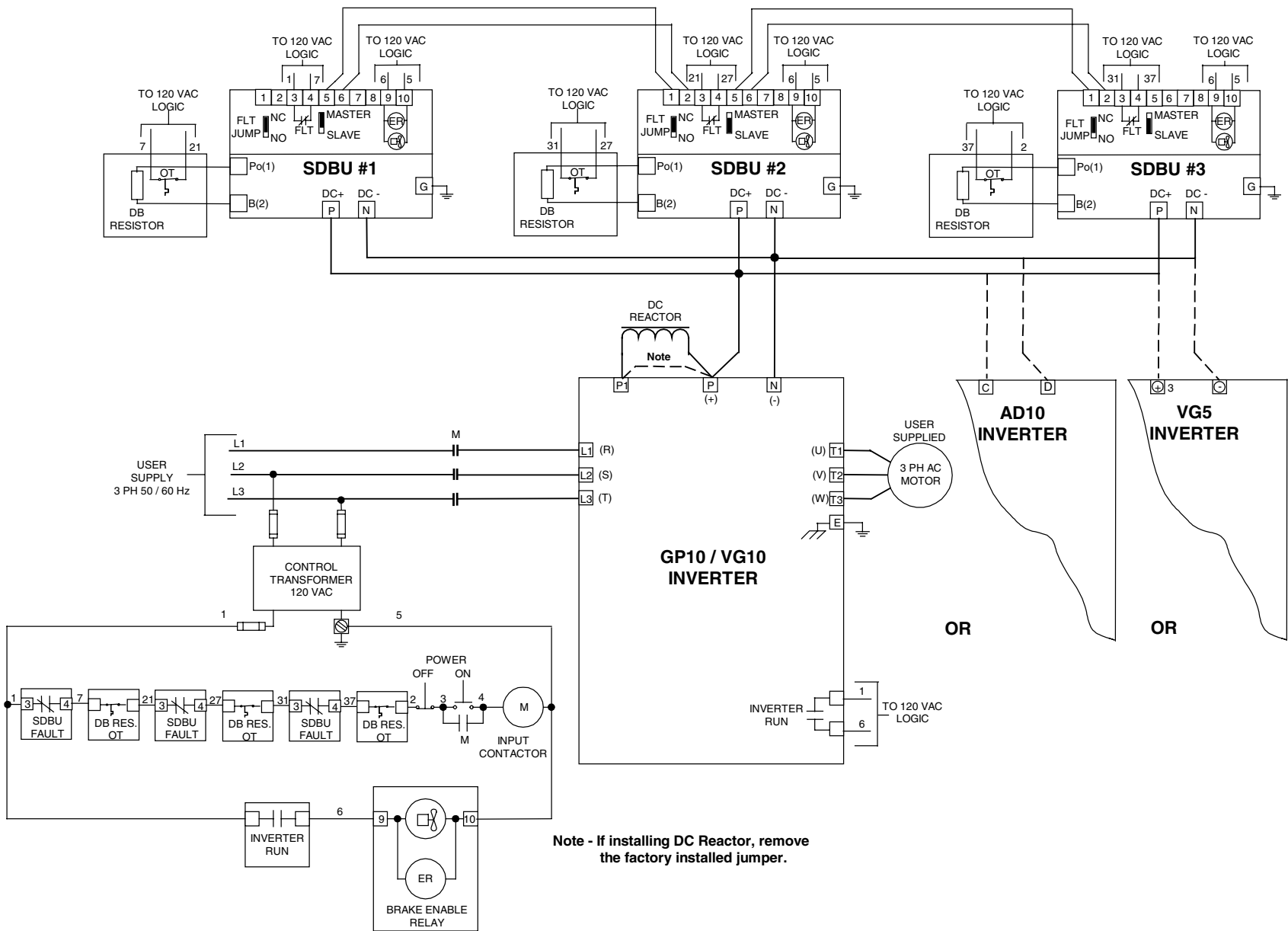

FIGURE 3 SDBU Parallel Connections





www.saftronics.com

TABLE 6 GP10 CT & VG10 Inverter Braking Unit and Resistor Table

HORSE POWER	BRAKING MODULE 10% DUTY	STANDARD RESISTOR 10% DUTY	BRAKING TORQUE 10% DUTY	BRAKING MODULE 30% HOIST DUTY	STANDARD RESISTOR 30% HOIST DUTY	BRAKING TORQUE 30% HOIST DUTY	CONNECTABLE MINIMUM RESISTANCE (OHMS)		
208 - 230 V									
0.75	NOT REQUIRED	100 ohm, 200w	150%	NOT REQUIRED	150 ohm, 400w	150%	100		
1		100 ohm, 200w	150%		150 ohm, 400w	150%	100		
2		40 ohm, 400w	150%		90 ohm, 800w	150%	33		
3		40 ohm, 400w	150%		60 ohm, 1.2kw	125%	33		
5		33 ohm, 400w	150%		36 ohm, 1.6kw	150%	33		
7.5		20 ohm, 800w	150%		24 ohm, 3kw	150%	15		
10		15 ohm, 900w	150%		18 ohm, 4kw	150%	15		
15		909-0001	9 ohm, 2.5kw		150%	909-0001	12 ohm, 6kw	150%	9
20		909-0001	6 ohm, 3kw		150%	909-0002	9 ohm, 7.5kw	150%	6
25		909-0001	5 ohm, 4kw		150%	909-0002	7 ohm, 9.5kw	150%	5
30	909-0001	5 ohm, 4kw	140%	909-0002	6 ohm 11kw	150%	5		
40	909-0002	3 ohm, 7kw	135%	909-0002	5 ohm, 15kw	150%	3		
50	909-0002	2.5 ohm, 8kw	150%	909-0002	4 ohm, 15kw	125%	2.5		
60	909-0002	2.5 ohm, 8kw	150%	909-0002 X2	6 ohm, 11kw X2	150%	2.5		
75	909-0002 X2	3.6 ohm, 5.5kw X2	150%	909-0002 X2	4 ohm, 14kw X2	150%	3.6		
100	909-0002 X2	3 ohm, 7kw X2	150%	909-0002 X2	4 ohm, 15kw X2	150%	3		
460 V									
0.75	NOT REQUIRED	200 ohm, 200w	150%	NOT REQUIRED	500 ohm, 400w	150%	200		
1		200 ohm, 200w	150%		500 ohm, 400w	150%	200		
2		160 ohm, 400w	150%		400 ohm, 650w	150%	130		
3		160 ohm, 400w	150%		250 ohm, 1.5kw	150%	130		
5		130 ohm, 400w	150%		150 ohm, 1.5kw	150%	130		
7.5		80 ohm, 800w	150%		110 ohm, 3kw	150%	60		
10		60 ohm, 900w	150%		80 ohm, 4kw	150%	60		
15		909-0003	40 ohm, 2.5kw		150%	909-0003	55 ohm, 6kw	150%	20
20		909-0003	30 ohm, 3kw		150%	909-0003	40 ohm, 8kw	150%	20
25		909-0003	22 ohm, 4kw		150%	909-0003	33 ohm, 9.5kw	150%	19.2
30	909-0003	22 ohm, 4kw	140%	909-0003	25 ohm, 12 kw	150%	19.2		
40	909-0003	16 ohm, 7kw	150%	909-0004	21 ohm, 15kw	150%	15.4		
50	909-0003	14 ohm, 7kw	135%	909-0004	16 ohm, 19kw	150%	12		
60	909-0003	10 ohm, 9kw	150%	909-0004	14 ohm, 22kw	150%	10		
75	909-0003	9 ohm, 10kw	140%	909-0004	11 ohm, 28kw	150%	8.3		
100	909-0004	7 ohm, 13kw	135%	909-0004	10 ohm, 30kw	125%	6.4		
125	909-0004	5 ohm, 18kw	150%	909-0004	7 ohm, 46kw	150%	5		
150	909-0004	5 ohm, 18kw	125%	909-0004 X2	11 ohm, 28kw X2	150%	5		
200	909-0004 X2	7 ohm, 13kw X2	135%	909-0004 X2	10 ohm, 30kw X2	125%	5.5		
250	909-0004 X2	5 ohm, 18kw X2	150%	909-0004 X3	10 ohm, 30kw X3	150%	5		
300	909-0004 X3	5.5 ohm, 16kw X3	125%	909-0004 X3	9.5 ohm, 32kw X3	130%	5		
400	909-0004 X3	5 ohm, 18kw X3	110%	909-0004b X4	9.5 ohm, 32kw X4	130%	5		

TABLE 7 AD10 Inverter Braking Unit and Resistor Table

HORSE POWER	BRAKING MODULE 10% DUTY	STANDARD RESISTOR 10% DUTY	BRAKING MODULE 30% HOIST DUTY	STANDARD RESISTOR 30% HOIST DUTY	CONNECTABLE MINIMUM RESISTANCE (OHMS)		
208 - 230 V							
0.75	NOT REQUIRED	100 ohm, 150W	NOT REQUIRED	50 ohm, 400W	50		
1		100 ohm, 150W		50 ohm, 400W	50		
1.5		80 ohm, 300W		50 ohm, 750W	50		
2		50 ohm, 300W		50 ohm, 750W	50		
3		40 ohm, 400W		34 ohm, 1.1KW	34		
5		40 ohm, 700W		34 ohm, 2KW	34		
7.5		20 ohm, 1.1KW		18 ohm, 3KW	18		
10		13 ohm, 1.4KW		8 ohm, 4KW	7.5		
15		8 ohm, 2.1KW		5 ohm, 5.5KW	5		
20		6 ohm, 3KW		5 ohm, 7.5KW	5		
25		5 ohm, 3.5KW		4 ohm, 9.5KW	3.8		
30		4 ohm, 4KW		4 ohm, 11KW	3.8		
40		909-0002		3 ohm, 7KW	909-0002	3 ohm, 15KW	3
50		909-0002		3 ohm, 7KW	909-0002	3 ohm, 15KW	3
60		909-0002		2.5 ohm, 8KW	909-0002 X2	6 ohm, 11KW X2	2.5
75	909-0002 X2	3.6 ohm, 5.5KW X2	909-0002 X2	4 ohm, 14KW X2	3.6		
100	909-0002 X2	3 ohm, 7KW X2	909-0002 X2	4 ohm, 15KW X2	3		
460V							
0.75	NOT REQUIRED	200 ohm, 150w	NOT REQUIRED	100 ohm, 400W	100		
1		200 ohm, 150w		100 ohm, 400W	100		
2		200 ohm, 300w		100 ohm, 750W	100		
3		160 ohm, 400W		100 ohm, 1.1KW	100		
5		100 ohm, 700W		100 ohm, 1.8KW	100		
7.5		80 ohm, 1.1KW		67 ohm, 2.8KW	67		
10		80 ohm, 1.4KW		67 ohm, 3.6KW	67		
15		40 ohm, 2.1KW		36 ohm, 5.5KW	36		
20		27 ohm, 2.8KW		26 ohm, 7.4KW	26		
25		22 ohm, 3.5KW		15 ohm, 9KW	15		
30		15 ohm, 4KW		10 ohm, 11KW	10		
40		12 ohm, 5.7KW		10 ohm, 15KW	10		
50		10 ohm, 7KW		7.5 ohm, 18KW	7.5		
60		7.5 ohm, 8.5KW		7.5 ohm, 22KW	7.5		
75		909-0003		7 ohm, 11kw	909-0004	11 ohm, 28KW	7
100	909-0004	7 ohm, 13KW	909-0004	10 ohm, 30KW	6.4		
125	909-0004	5 ohm, 18KW	909-0004 X2	13 ohm, 23KW X2	5		
150	909-0004	5 ohm, 18KW	909-0004 X2	11 ohm, 28KW X2	5		
200	909-0004 X2	7 ohm, 13KW X2	909-0004 X2	10 ohm, 30KW X2	5.5		
250	909-0004 X2	5 ohm, 18KW X2	909-0004 X3	10 ohm, 30KW X3	5		
300	909-0004 X2	5 ohm, 18KW X2	909-0004 X3	9.5 ohm, 32KW X3	5		
400	909-0004 X3	5 ohm, 18KW X3	909-0004 X4	9.5 ohm, 32KW X4	5		
500	909-0004 X4	5 ohm, 18KW X4	909-0004 X4	9.5 ohm, 32KW X4	5		

0-400HP MINIMUM OF 120% BRAKING TORQUE, 500HP MINIMUM OF 105%

TABLE 8 VG5 Inverter Braking Unit and Resistor Table

HORSE POWER	BRAKING MODULE 10% DUTY	STANDARD RESISTOR 10% DUTY	BRAKING TORQUE 10% DUTY	BRAKING MODULE 30% HOIST DUTY	STANDARD RESISTOR 30% HOIST DUTY	BRAKING TORQUE 30% HOIST DUTY	CONNECTABLE MINIMUM RESISTANCE (OHMS)
208 - 230 V							
1	NOT REQUIRED	135 ohm, 150w	150%	NOT REQUIRED	150 ohm, 400w	150%	48
2		60 ohm, 300w	150%		90 ohm, 800w	150%	16
3		40 ohm, 500w	150%		60 ohm, 1.2kw	150%	16
5		25 ohm, 800w	150%		36 ohm, 1.6kw	125%	16
7.5		15 ohm, 1.5kw	150%		24 ohm, 3kw	150%	9.6
10		12 ohm, 1.5kw	150%		18 ohm, 4kw	150%	9.6
15	909-0001	9 ohm, 2.5kw	150%	909-0001	12 ohm, 6kw	150%	9
20	909-0001	6 ohm, 3kw	150%	909-0002	9 ohm, 7.5kw	150%	6
25	909-0001	5 ohm, 4kw	150%	909-0002	7 ohm, 9.5kw	150%	5
30	909-0001	5 ohm, 4kw	140%	909-0002	6 ohm 11kw	150%	5
40	909-0002	3 ohm, 7kw	135%	909-0002	5 ohm, 15kw	150%	3
50	909-0002	3 ohm, 7kw	135%	909-0002	4 ohm, 15kw	125%	3
60	909-0002	2.5 ohm, 8kw	150%	909-0002 X2	6 ohm, 11kw X2	150%	2.5
75	909-0002 X2	3.6 ohm, 5.5kw X2	150%	909-0002 X2	4 ohm, 14kw X2	150%	3.6
100	909-0002 X2	3 ohm, 7kw X2	150%	909-0002 X2	4 ohm, 15kw X2	150%	3
460 V							
1	NOT REQUIRED	600 ohm, 200w	150%	NOT REQUIRED	500 ohm, 400w	150%	64
2		300 ohm, 300w	150%		400 ohm, 650w	150%	64
3		200 ohm, 450w	150%		250 ohm, 1.5kw	150%	32
5		110 ohm, 800w	150%		150 ohm, 1.5kw	150%	32
7.5		80 ohm, 1.1kw	150%		110 ohm, 3kw	150%	32
10		60 ohm, 1.5kw	150%		80 ohm, 4kw	150%	32
15		40 ohm, 2.5kw	150%		55 ohm, 6kw	150%	20
20		30 ohm, 3kw	150%		40 ohm, 8kw	150%	20
25		22 ohm, 4kw	150%		33 ohm, 9.5kw	150%	19.2
30		909-0003	22 ohm, 4kw		140%	909-0003	25 ohm, 12 kw
40	909-0003	16 ohm, 7kw	150%	909-0004	21 ohm, 15kw	150%	15.4
50	909-0003	14 ohm, 7kw	135%	909-0004	16 ohm, 19kw	150%	12
60	909-0003	10 ohm, 9kw	150%	909-0004	14 ohm, 22kw	150%	10
75	909-0003	9 ohm, 10kw	140%	909-0004	11 ohm, 28kw	150%	8.3
100	909-0004	7 ohm, 13kw	135%	909-0004	10 ohm, 30kw	125%	6.4
150	909-0004	5 ohm, 18kw	125%	909-0004 X2	11 ohm, 28kw X2	150%	5
200	909-0004 X2	7 ohm, 13kw X2	135%	909-0004 X2	10 ohm, 30kw X2	125%	5.5
250	909-0004 X2	5 ohm, 18kw X2	150%	909-0004 X3	10 ohm, 30kw X3	150%	5

Table continues on page 14



TABLE 8 VG5 Inverter Braking Unit and Resistor Table Con't

HORSE POWER	BRAKING MODULE 10% DUTY	STANDARD RESISTOR 10% DUTY	BRAKING TORQUE 10% DUTY	BRAKING MODULE 30% HOIST DUTY	STANDARD RESISTOR 30% HOIST DUTY	BRAKING TORQUE 30% HOIST DUTY	CONNECTABLE MINIMUM RESISTANCE (OHMS)
575V							
2	NOT REQUIRED	150 ohm, 560w	400%	NOT REQUIRED	300 ohm, 1.5kw	315%	150
3		150 ohm, 560w	300%		300 ohm, 1.5kw	200%	150
5		150 ohm, 560w	180%		250 ohm, 2kw	150%	130
7.5		125 ohm, 1.1kw	150%		170 ohm, 3kw	150%	90
10		95 ohm, 1.5kw	150%		125 ohm, 3.7kw	150%	65
15		60 ohm, 2.1kw	150%		85 ohm, 5.5kw	150%	44
20		50 ohm, 3kw	150%		64 ohm, 7.5kw	150%	32
25		35 ohm, 3.5kw	150%		50 ohm, 9.2kw	150%	26
30		30 ohm, 4.2kw	150%		42 ohm, 11kw	150%	26
40		909-0005	24 ohm, 6kw		150%	909-0005	30 ohm, 15kw
50	909-0005	20 ohm, 7kw	150%	909-0006	25 ohm, 18.5kw	150%	18
60	909-0005	16 ohm, 8.5kw	150%	909-0006	21 ohm, 20kw	150%	15.3
75	909-0005	13 ohm, 10kw	150%	909-0006	17ohm, 27.5kw	150%	12.3
100	909-0005	10 ohm, 14kw	150%	909-0006 X2	26 ohm, 18.5kw X2	150%	9.6
125	909-0006	8 ohm, 17kw	150%	909-0006 X2	20 ohm, 23kw X2	150%	7.3
150	909-0006	6.5 ohm, 21kw	150%	909-0006 X2	17 ohm, 27.5w X2	150%	6.5
200	909-0006	6.3 ohm, 23kw	150%	909-0006 X3	19 ohm, 24.5w X3	150%	6.3

7.0 SDBU DIMENSIONAL OUTLINE

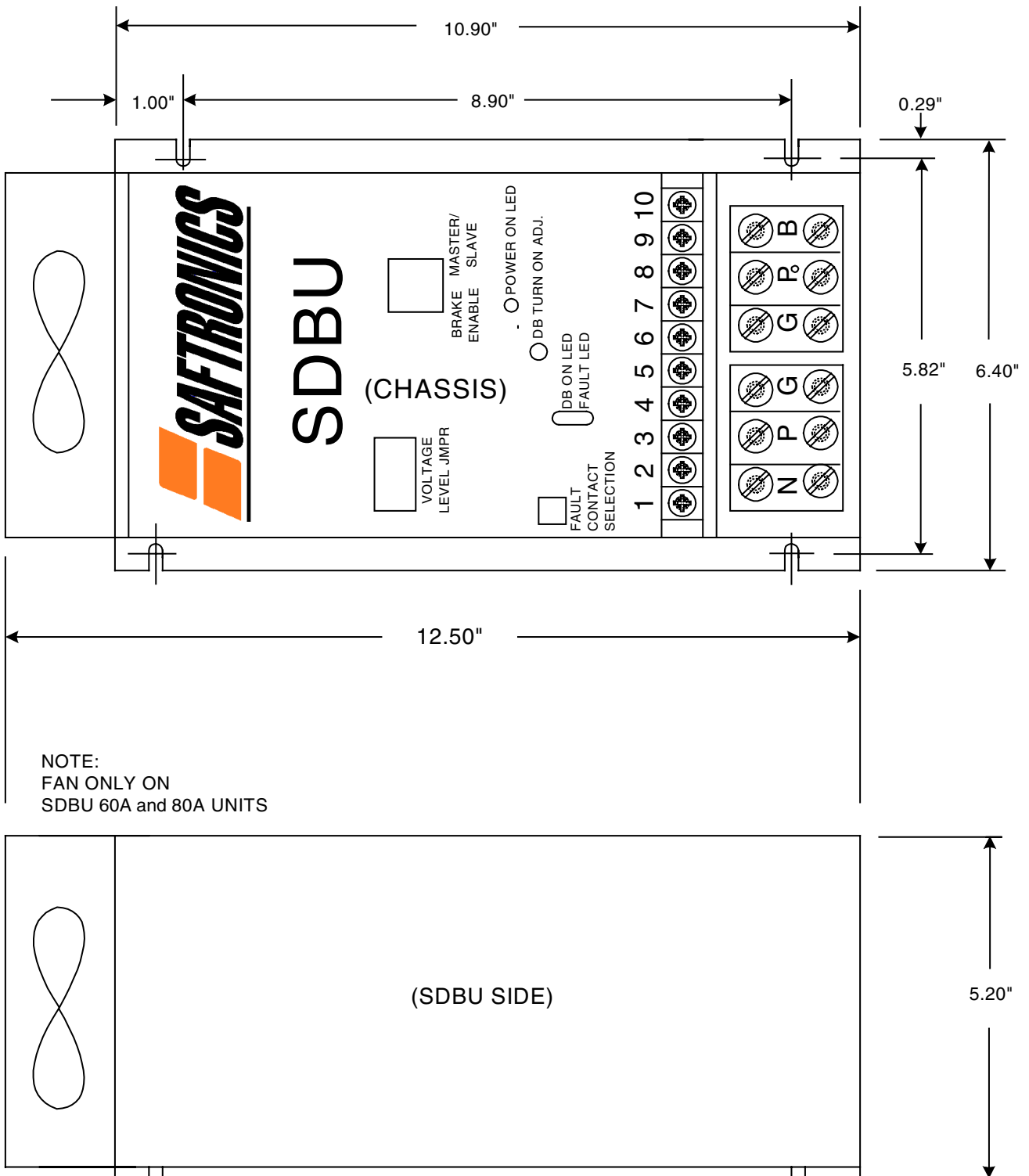

8.0 WARRANTY

Saftronics warrants to Buyer that products and any services furnished hereunder will be free from defects in material, workmanship, and title and will be of the kind and quality specified in Safronics quotation. The foregoing shall apply only to failures to meet said warranties (excluding any defects in title) which appear within one year from the date of shipment hereunder; provided, however, that if Buyer, in the course of its regular and usual business, transfers title to or leases such products (including equipment incorporating such products) to a third party, such period shall run until one year from such transfer or lease or eighteen months from shipment by Safronics, whichever occurs first. The warranties and remedies set forth herein are conditioned upon (a) proper storage, installation, use and maintenance, and conformance with any applicable recommendations of Safronics and (b) Buyer promptly notifying Safronics of any defects and, if required, promptly making the product available for correction. If any product or service fails to meet the foregoing warranties (except title), Safronics shall thereupon correct any such failure either, as its option, (i) by repairing any defective or damaged part or parts of the products, or (ii) by making available F.O.B. Safronics plant or other point of shipment, any necessary repair or replacement parts. Where a failure cannot be corrected by Safronics reasonable efforts, the parties will negotiate an equitable adjustment in price. The preceding paragraph sets forth the exclusive remedies for claims (except as to title) based on defect in or failure of products or services, whether claim is in contract or tort (including negligence and however instituted). Upon expiration of the warranty period, all such liability shall terminate. The foregoing warranties are exclusive and in lieu of all other warranties, whether written, oral, implied or statutory. **No implied statutory warranty or merchantability or fitness for particular purpose shall apply.** Safronics does not warrant any products or services of others which Buyer has designated.