

# Autonics

## TEMPERATURE/HUMIDITY CONTROLLER

### THD SERIES

# M A N U A L



Thank you very much for selecting Autonics products.  
**For your safety, please read the following before using.**

### Caution for your safety

- ※Please keep "Caution for your safety" to avoid accidents or damages as using it correctly.
- ※The meaning of 'Warning' and 'Caution' is as follows:
  - Warning** In case a serious injury or dead may be occurred.
  - Caution** In case a little injury or a damage of this unit may be occurred.
- ※The meaning of the mark on the product and manual is as follows:
  - ▲ is a caution mark for danger in special condition.

### Warning

- Please use it with double safety devices when it is used at the equipments which may cause damages to human life or assets(Ex:Nuclear power control, Medical equipment, Vehicle, Train, Air plane, Combustion apparatus, Entertainment or Safety device etc.)**  
It may cause a fire, human injury and damage.
- Do not connect, check or repair the product when power is ON.**  
It may give an electric shock.
- Do not disassemble and modify this unit. When it requires, please contact us.**  
It may cause an electric shock or fire.
- Please check the polarity before connecting wires.**  
It may cause a fire.

### Caution

- This unit shall not be used outdoors.**  
It may shorten the life cycle of the product.
- Do not touch the temperature/humidity sensor by hands.**
- This unit must be mounted on panel.**  
It may cause a malfunction.
- For cleaning the unit, do not use water or an oil-based detergent but a dry towel.**  
It may cause an electric shock or fire.
- Do not use this unit at place where there are flammable or explosive gas, humidity, direct ray the sun, radiant heat, vibration, impact etc.**  
It may cause explosion or fire.
- Do not inflow dust or wire dregs into inside of this unit.**  
It may cause fire or mechanical problem.
- Do not unfasten the detecting head except for Autonics engineers.**  
It may cause a breakdown of sensor.

### Ordering information

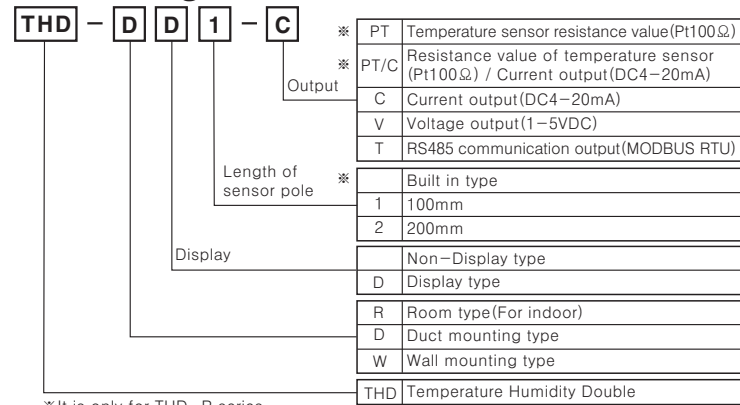

### Dimensions

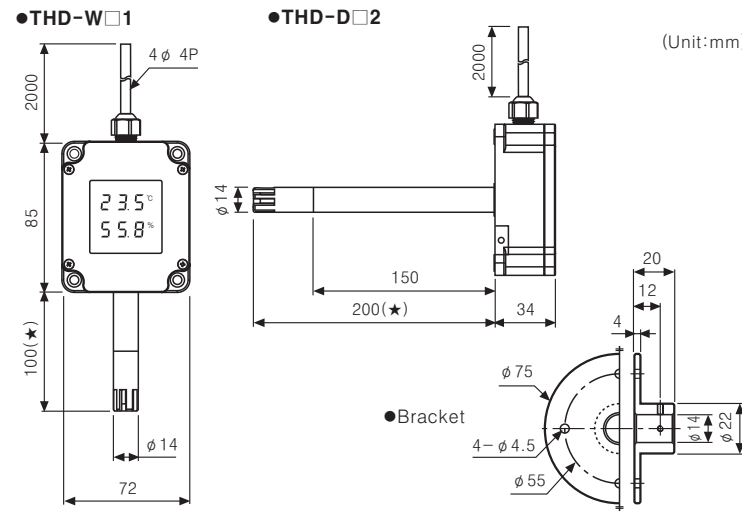
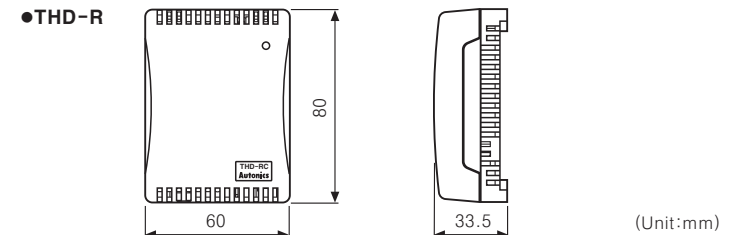

### Specifications

Model	THD-R-PT	THD-R-PT/C	THD-R-□	THD-D-□ THD-W-□	THD-DD-□ THD-WD-□
Power supply	24VDC ±10%				
Power consumption	Max. 2.4W				
Input	Pt100Ω (Built in type)	Pt100Ω/Humidity (Built in type)	Temp., Humidity sensor(Built in type)		
Display type	Non-Display				7Segment LED Display(3Digit for temperature, humidity)
Measuring range	Temp.	-19.9~60.0°C			
	Humidity	0.0~99.9%RH(THD-R series is required to attend for using over 90%RH)			
Accuracy	Temp.	Max. ±0.8°C -19.9~5.0°C: ±1°C, 5.0~40.0°C: ±0.5°C, 40~60.0°C: ±1°C rdg ±1digit(Under -10°C, it is within 1.5°C)			
	Humidity	30~70%RH to Max. ±3%RH (at 25°C)			
Output	PT100Ω resistance value output	DC4~20mA (Allowable impedance max. 600Ω)	DC4~20mA(Allowable impedance max. 600Ω), 1~5VDC, RS485(MODBUS RTU) communication output, Temp.:Resolution 0.02mA/°C, Resolution 0.02mA/%RH		
Sampling period	Fixed 0.5sec.				
Insulation resistance	Min. 100MΩ (500VDC)				
Dielectric strength	500VAC 50/60Hz for 1 minute				
Noise strength	±0.3kV the square wave noise(pulse width:1μs) by the noise simulator				
Vibration	Mechanical	0.75mm amplitude at frequency of 10 ~ 55Hz in each of X, Y, Z directions for 1hour			
Malfunction		0.5mm amplitude at frequency of 10 ~ 55Hz in each of X, Y, Z directions for 10minutes			
Shock	Mechanical	300m/s <sup>2</sup> (30G) in X, Y, Z directions for 3 times			
Malfunction		100m/s <sup>2</sup> (10G) in X, Y, Z directions for 3 times			
Protection		IP10	IP65(except sensor part)		
Ambient temperature	-20 ~ 60°C(at non-freezing status)				
Storage temperature	-20 ~ 60°C(at non-freezing status)				
Weight	Approx. 55g			Approx. 160g	

### Terminal connection

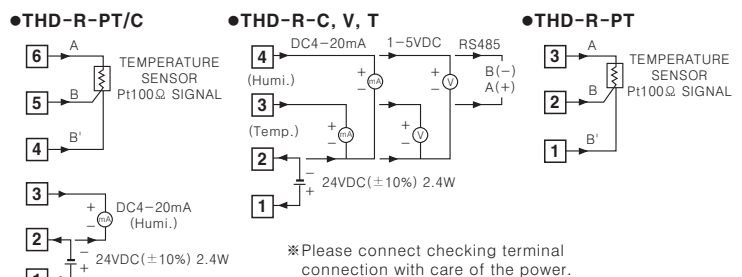

### THD-D, THD-DD, THD-W, THD-WD Series

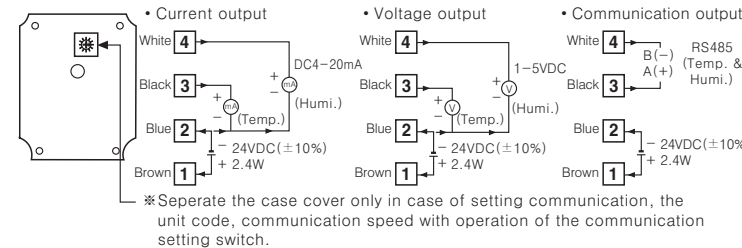

### Case detachment

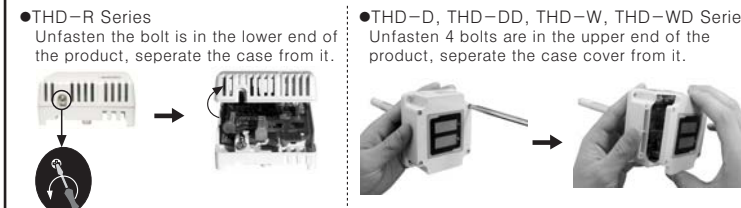

### Current output

It transmits current temperature/humidity to other equipments, PC and recorder and outputs 4~20mADC. It outputs 4mADC at -19.9°C of temperature and 0%RH of humidity, 20mADC on the 60°C of temperature and 100%RH of humidity.  
 ※Temperature output and humidity output are divided with 800 division for resolution.

### Voltage output

It transmits current temperature/humidity to other equipments, PC and recorder, and outputs 1~5VDC. It outputs 1VDC on the -19.9°C of temperature and 0%RH of humidity. And it outputs 5VDC on the 60°C of temperature and 100%RH of humidity.  
 Temperature output and humidity output are divided with 800 division for resolution.

### Temp. sensor output(Pt 100Ω output)

It transmits current temperature/humidity to other equipments, recorder or thermometer. It outputs 100Ω at 0°C and 119.40Ω (123.25Ω) at 50°C (or 60°C). (TCR=3850ppm/°C)

### RS485 communication output

It is used to transmit current temperature and humidity to other equipment.

#### Interface

Standard	EIA RS485
Maximum connections	31(Address setting:01~31)
Communication method	2-wire half duplex
Communication type	Asynchronous
Effective communication distance	Max. 800m
Communication speed	1200~115200bps(Setting)
Start bit	1(Fixed)
Stop bit	1(Fixed)
Parity bit	None(Fixed)
Data bit	8bit(Fixed)
Protocol	MODBUS RTU

※During the communication operation between THD and upper system, editing the parameter is unavailable.  
 ※Correct the parameter of THD communication to be same as upper system.  
 ※It is not allowed to set overlapping communication address at the same communication line.  
 ※Please use a proper twist pair for RS485 communication.

#### Application of system organization

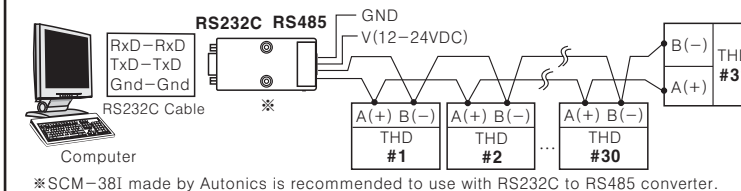

#### SCM-381 made by Autonics is recommended to use with RS232C to RS485 converter.

#### Ordering of communication control

- The communication method is MODBUS RTU(PI-MBUS-300 REV.J).
- After 0.5sec. being supplied the power into upper system, then able to start communication.
- The initial communication will be started by upper system.

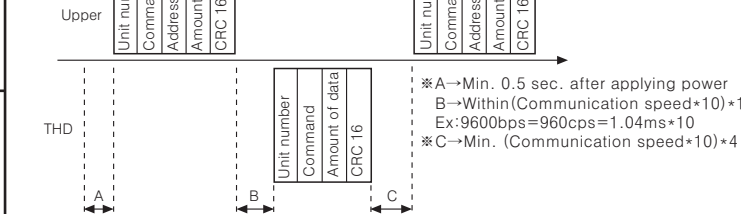

#### Communication command and block

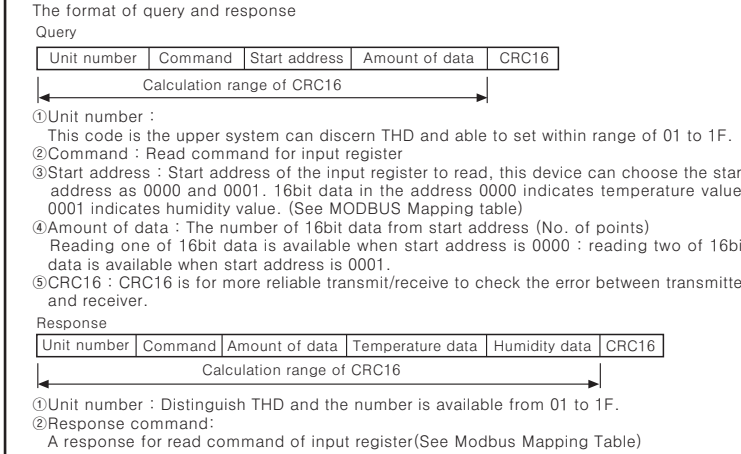

- ③Amount of data : The number of 16bit data on start code. (No. of Points) Reading 4 of 8bit data is available when start address is 0000:reading two of 8 bit data is available when start address is 0001. (See MODBUS Mapping Table)
- ④Temperature data : To get a current temperature value, divide read value by 100. Ex)When read data is 0x09B6, decimal value is 2486, the current value is 2486/100=24.86°C.
- ⑤Humidity data : To get a current humidity value, divide read value by 100. Ex)When read data is 0x12FE, decimal value is 4862, the current value is 2486/100=48.62%Rh.
- ⑥CRC16:Check the whole frame.

#### Application for communication command

(Query) : Unit number(01), Start code(0000), The number of read data, 16bit(2) Check sum(0x71CB)

Unit number	Command	Start code	Amount of data	CRC16
01	04	00	00	02
		High	Low	High
		High	Low	High
01	04	00	00	02
		High	Low	High
		High	Low	High

(Response) : Unit number(01), The number of read data, 8bit(4), Temperature(0x09B6), Humidity(0x12FE), CRC Check sum(0x94DE)

Unit number	Response command	Amount of data	Temperature data	Humidity data	CRC16
01	04	04	09	B6	12
			High	Low	High
			High	Low	High
01	04	04	09	B6	12
			High	Low	High
			High	Low	High

#### Error handling(Slave → Master)

- Non support command
 

Unit number	Response command	Exception code	CRC16
01	81	01	81
			90

  - ※Set a received the highest bit and send it to response command and exception code 01.
- A start code of queried data is inconsistent with the transmittable code.
 

Unit number	Response command	Exception code	CRC16
01	81	02	81
			90

  - ※Set a received the highest bit and send it to response command and exception code 02.
- Amount of queried data is inconsistent with a transmittable one.
 

Unit number	Response command	Exception code	CRC16
01	84	03	X
			X

  - ※Set a received the highest bit and send it to response command and exception code 04.
- Abnormal operation for command
 

Unit number	Response command	Exception code	CRC16
01	84	04	X
			X

  - ※Set a received the highest bit and send it to response command and exception code 04.

#### MODBUS Mapping Table

Address	Item	Remark
30001(0000)	Temperature value	Temperature value +0.01
30002(0001)	Humidity value	Humidity value +0.01

#### Setting a communication speed

- Set SW1 to 0 and apply power.
- Operation indicator LED is flickering.
- Set a communication speed after choosing SW1 within the range 1~8, and hold it for 3sec.
- After setting a communication speed, LED will be ON. At the moment turn OFF the power.
- Factory default is 9600bps.

※Setting table for communication speed

SW1	Communication speed(BPS)
1	1200
2	2400
3	4800
4	9600
5	19200
6	38400
7	57600
8	115200

#### Set a 485 communication unit no.(01~31)

- Set SW1 within 1~F and apply power.
- Unit number is set automatically and it operates with 485 communication mode.
- Factory default is 01.

※Setting table for unit number

CAL contact	SW1	Unit no.	CAL contact	SW1	Unit no.	CAL contact	SW1	Unit no.
OPEN	1	01	OPEN	D	13	SHORT	A	25
OPEN	2	02	OPEN	E	14	SHORT	A	26
OPEN	3	03	OPEN	F	15	SHORT	B	27
OPEN	4	04	SHORT	0	16	SHORT	C	28
OPEN	5	05	SHORT	1	17	SHORT	D	29
OPEN	6	06	SHORT	2	18	SHORT	E	30
OPEN	7	07	SHORT	3	19	SHORT	F	31
OPEN	8	08	SHORT	4	20			
OPEN	9	09	SHORT	5	21			
OPEN	A	10	SHORT	6	22			
OPEN	B	11	SHORT	7	23			
OPEN	C	12	SHORT	8	24			

### Caution for using

- Read below cautions before using the product.
  - Do not touch the sensor module.
  - Fix the product THD-R Series on the wall for using.
  - Cautions for cleaning
    - Use dry towel
    - Do not use acid, chrome acid, solvent but alcohol.
    - Clean after turning off the power. Turn on the power after passing 30min.
  - Be sure that metal dust and wire-dregs are not flowed in the unit.
  - Connect the wires after checking polarity.
  - Please use separated line from high voltage line or power line in order to avoid inductive noise.
  - Keep away from the high frequency instruments. (High frequency welding machine & sewing machine, big capacitive SCR controller)
  - The switch or circuit-breaker should be installed near by users.
  - Installation environment
    - It shall be used indoor
    - Altitude Max. 2000m
    - Pollution Degree 2
    - Installation Category I
- ※It may cause malfunction if above instructions are not followed.

### Major products

**Autonics Corporation**  
<http://www.autonics.com>  
**Global Partner for IA**

■ PROXIMITY SENSOR ■ PHOTOELECTRIC SENSOR  
 ■ AREA SENSOR ■ FIBER OPTIC SENSOR  
 ■ DOOR/DOOR SIDE SENSOR  
 ■ PRESSURE SENSOR  
 ■ ROTARY ENCODER ■ COUNTER  
 ■ TIMER ■ TEMPERATURE CONTROLLER  
 ■ TEMPERATURE/HUMIDITY TRANSDUCER  
 ■ POWER CONTROLLER ■ PANEL METER  
 ■ TACHO/LINE SPEED/PULSE METER  
 ■ DISPLAY UNIT ■ SENSOR CONTROLLER  
 ■ SWITCHING POWER SUPPLY  
 ■ GRAPHIC PANEL  
 ■ 5-PHASE STEPPING MOTOR & DRIVER  
 ■ CONTROLLER  
 ■ LASER MARKING SYSTEM(CO<sub>2</sub>, Nd:YAG)

■ HEADQUARTERS : 41-5, Yongdang-ro, Ulsung-sa, Gyeongsang-si, Gyeongsang-do, 626-847, Korea  
 ■ OVERSEAS SALES : Bldg. 402 3rd Fl., Bucheon Techno Park, 193, Yaksdae-dong, Wonmi-gu, Bucheon-si, Gyeonggi-do, 420-734, Korea  
 TEL:82-32-610-2730 / FAX:82-32-329-0728  
 E-mail : sales@autonics.com

EP-KE-03-0200