

**Autonics**

**TEMPERATURE CONTROLLER**  
**TC3YT SERIES**

M A N U A L



Thank you very much for selecting Autonics products.  
For your safety, please read the following before using.

**Caution for your safety**

- Please keep these instructions and review them before using this unit.
- Please observe the cautions that follow:
- Warning** Serious injury may result if instructions are not followed.
- Caution** Product may be damaged, or injury may result if instructions are not followed.
- The following is an explanation of the symbols used in the operation manual.
- Caution:** Injury or danger may occur under special conditions.

**Warning**

- In case of using this unit with machineries(Nuclear power control, medical equipment, vehicle, train, airplane, combustion apparatus, entertainment or safety device etc), it requires installing fail-safe device, or contact us for information on type required.
- It may result in serious damage, fire or human injury
- It must be mounted on Panel.
- Do not connect terminals when it is power on.
- Before connecting power, check the terminal number.
- Do not disassemble and modify this unit, when it requires.

**Caution**

- This unit shall not be used outdoors.
- For wire connection, No.12-28AWG should be used and screw bolt on terminal block with 0.3N · m to 0.4N · m strength.
- Please observe specification rating.
- Do not use the load beyond rated switching capacity of Relay contact.
- In cleaning the unit, do not use water or an oil-based detergent.
- Do not use this unit at place where there are flammable or explosive gas, humidity, direct ray the sun, radiant heat, vibration, impact etc.
- Do not inflow dust or wire dregs into inside of this unit.
- Before connecting wires, check the terminal polarity.

**Front panel identification**

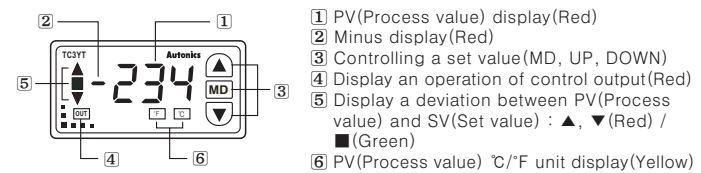

**Dimensions**

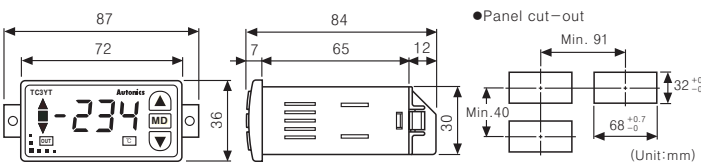

**Connections**

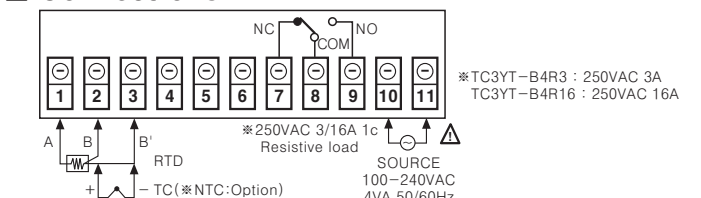

**Set and change a SV**

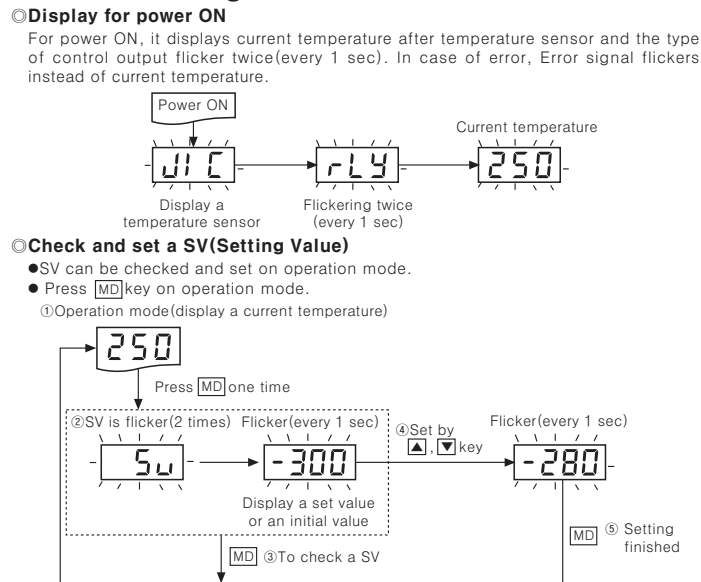

- PV is displayed on operation mode.
- Press MD key, the SV is indicated after "5u" is flickering 2 times.
- In case of checking the SV only, after check it pressing MD key, then it returned to the drive mode.
- In case of changing and setting the SV, set it with ▲, ▼ keys. If you press ▲, ▼ keys continuously, the SV is increased/decreased with high-speed.
- If press MD key after setting, the set value is saved and the mode returns to operation.

**Input specification and range**

Input		Using range	
Sensor	Parameter	°C	°F
K	ECR	0 ~ 999	32 ~ 999
J	JIC	0 ~ 400	32 ~ 752
Pt H	PEH	0 ~ 400	32 ~ 752
Pt L	PEL	-99 ~ 199	-146 ~ 390

- A temperature sensor converts temperature into electrical signal so that a controller can do ON/OFF the control output.
- The setting is available with the using range.
- The setting range of the SV is limited within the using temperature range.
- Using temperature : It can be set as °C, °F are displayed on the front side.
- The above specification are changeable without notice anytime.

**Ordering information**

	TC	3	Y	T	-	B	4	R	3
	①	②	③	④		⑤	⑥	⑦	⑧
① Item	TC	Temperature Controller							
② Digit	3	3 Digit							
③ Size	Y	DIN W72×H36mm							
④ Setting type	T	Touch S/W single setting type							
⑤ Control mode	B	ON/OFF and proportional control(common use)							
⑥ Power supply	4	100~240VAC 50/60Hz							
⑦ Control output	R	Relay output							
⑧ Relay capacity	3	250VAC 3A 1c	16	250VAC 16A 1c					

**Specifications**

	TC3YT-B4R3	TC3YT-B4R16
Model	TC3YT-B4R3	TC3YT-B4R16
Power supply	100~240VAC 50/60Hz	
Allowable voltage range	90 to 110% of rated voltage	
Power consumption	Approx. 4VA	
Display method	7Segment Red LED Display	
Character size	W7.4 × H15mm	
Input type(※)	TC:K(CA), J(IC), RTD : Pt100Ω(DIN)	
Control output	Relay output 250VAC 3A 1c	Relay output 250VAC 16A 1c
Control method	ON/OFF and proportional control (common use)	
Hysteresis	1 ~ 100°C	
Proportional band	0 ~ 100%	
Offset correction	0 ~ 100%	
Control period	1 ~ 120sec	
Display method	±1digit with a bigger one of ±0.5% of PV or ±1°C	
Setting type	Setting by front push buttons	
Sampling period	500ms	
Dielectric strength	2000VAC 60Hz for 1 minute(between external terminal and case)	
Vibration	0.75mm amplitude at frequency of 10 to 55Hz in each of X, Y, Z directions for 1 hours	
Relay life cycle	Min.100,000 times (250VAC 3A resistive load)	Min.100,000 times (250VAC 16A resistive load)
Insulation resistance	Min. 100MΩ(at 500VDC)	
Noise strength	±2kV R-phase and S-phase (pulse width 1μs)	
Memory retention	Approx. 10 years (When using non-volatile semiconductor memory type)	
Ambient temperature	-10 ~ 50°C(at non-freezing status)	
Storage temperature	-20 ~ 60°C(at non-freezing status)	
Ambient humidity	35 ~ 85%RH	
Protection	IP65	
Weight	Approx. 99g	Approx. 103g

**Flow chart for first setting group**

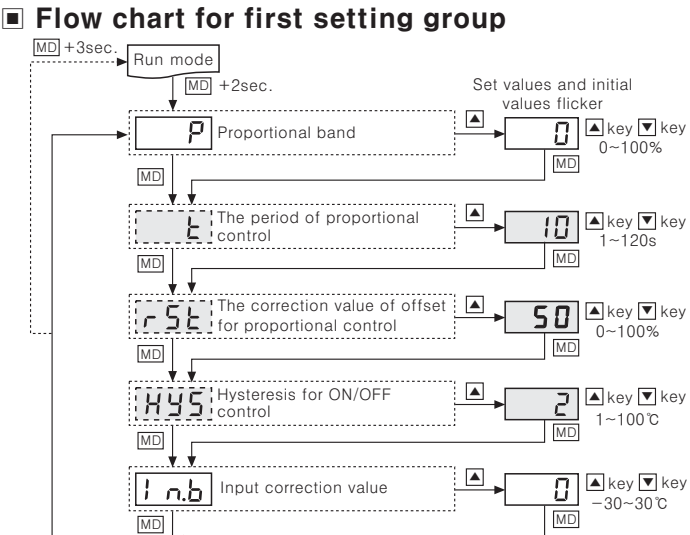

- In operation mode, if press MD key for 2 sec., it enters setting group 1.
- At the beginning of MD key input, 5u signal is displayed. And then P signal, the first mode of group 1 is displayed for 2-3 sec. It enters the first mode of group 1 for finishing press MD.
- Parameter will be displayed when entering setting mode.
- Press MD key one time, parameter move to the next. Moreover for changing a set value, press ▲ key. (Set value is flickering every one sec.)
- Press a MD key after changing a set value or for the statue of setting change, the setting value is saved and the parameter is changed to the next.
- In any moment during the setting operation, if press MD key for 3 sec., the changed value is saved and the mode is changed to operation mode.
- When there is no input for 1 min. for setting operation, it returns to operation mode and the parameter set value is not changed the prior value is saved.
- When P is not "0", [HY5] parameter is not displayed.
- When P is "0", ON/OFF control, [t] and [r5t] parameter is not displayed.
- When it is entered to the setting mode for all cases, applicable parameters will be displayed.

**Flow chart for second setting group**

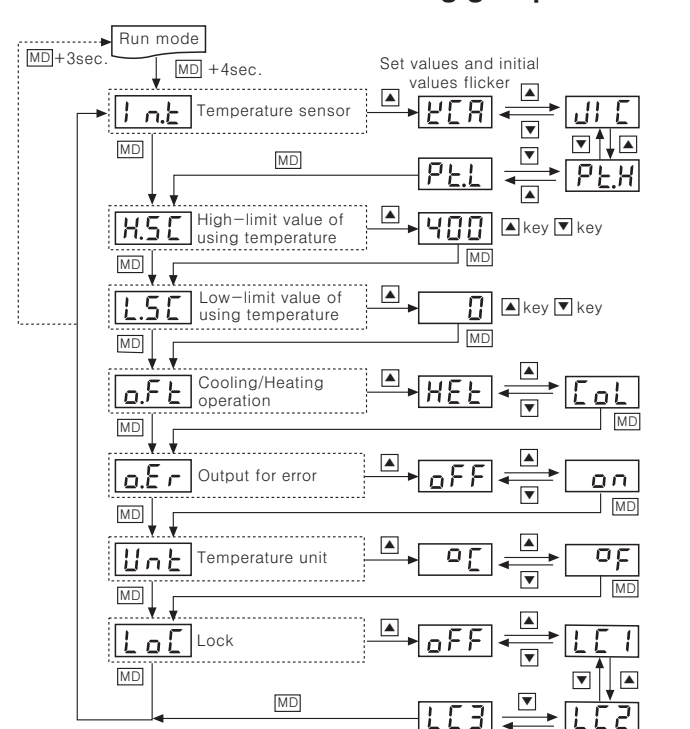

- In operation mode, if press MD key for 4 sec., it enters setting group 2.
- At the beginning of MD key input, 5u signal is displayed. And then P signal, the first mode of group 2, is displayed for 2-3 sec. for the moment of 4 sec past, Inb, the first mode of setting group 2, is displayed. It enters the first mode of group 2 for finishing press MD key.
- Parameter will be displayed when entering setting mode.
- Press MD key one time, parameter move to the next. Moreover for changing a set value, press ▲ key. (Set value is flickering every one sec.)
- Press a MD key after changing a set value or for the statue of setting change, the setting value is saved and the parameter is changed to the next.
- In any moment during the setting operation, if press MD key for 3 sec., the changed value is saved and the mode is changed to operation mode.
- When there is no input for 1 min. for setting operation, it returns to operation mode and the parameter set value is not changed the prior value is saved.
- When it is entered to the setting mode for all cases, applicable parameters are displayed.
- When the unit of the using temperature is changed, the SV is changed as 0°C.

**Functions**

- Input correction [Inb]**
  - Input revise corrects the deviation, occurred from temperature sensor such as thermocouples, RTD, Analogue sensor etc.
  - There are grades for temperature sensor and high accuracy one is a high price, normal products are usually used. Check the deviation of every thermo sensor precisely to measure temperature accurately.
  - Use this mode after measuring deviation occurred from temperature sensor exactly because if measured deviation value is not correct, displayed temperature will be too high or too low.
  - Setting range : -49 ~ 50°C (Factory default : 0°C)
  - Ex) When even though current temperature is 80°C, display value is 78°C, input correction value should be 2 to display 80°C.
- Hysteresis [HY5]**
  - In the ON/OFF control, the ON/OFF interval of the output is required, this interval is hysteresis. When this interval is too narrow, it causes hunting such as chattering by external noise.
  - For ON/OFF control, even when control is stable, there is hunting.
  - Because the hunting is generated by combined cause, HY5 set value, response spec, sensor position, etc., it is not regular. To minimize it, proper HY5 value, the capacity and characteristic of heater, and response and position of sensor need to be considered.
  - Setting range : 1 ~ 100°C (Factory default : 2°C)
- Proportional band [P]**
  - If current temperature(PV) is within the proportional control, it controls the ratio of ON and OFF during proportional control. At this moment the term of proportional control for set value is called proportional band.
  - Setting range : 0 ~ 100% (Factory default : 0%)
- Control period (Proportional control) [t]**
  - When output the control value by using relay and SSR on the proportional control, it repeats ON for set time and OFF.
  - The set time is called proportional control period.
  - Setting range : 1 ~ 120s (Factory default : 10s)
- Setting range**
  - Hysteresis / proportional band / proportional period is set on parameter
  - Setting range of hysteresis [HY5] : 1 ~ 100°C
  - Setting range of proportional band [P] : 0 ~ 100%
  - Setting range of control period [t] : 1 ~ 120sec
  - ON/OFF control ↔ Proportional control conversion: When P is 0%, it is ON/OFF control: if there is a value for P, is proportional control. The parameter of hysteresis [HY5] appears when [P], proportional band, is 0%.
- Offset correction / Manual reset [r5t]**
  - When use the proportional control, even when it is stable statue, deviation can occur because of heat capacity and heater capacity. It is called offset.
  - Offset is set on the parameter of inner manual reset [r5t].
  - Offset correction is used only for proportional control. (Not for [P]=0%). Therefore if proportional band [P] is set as 0%, manual reset parameter [r5t] is not shown.
  - Setting range : 0~100% (Factory default : 50%)
  - Set a value as 50% when PV is equal to SV. After control is stable, if measured temperature is lower than SV, set value is over than 50%, otherwise lower than 50%.
  - Controlling a manual reset [r5t] by control result

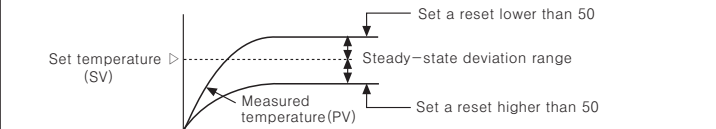

**Control mode switch**

- User can choose ON/OFF and proportional control.
- ON/OFF control** - Proportional control conversion: When P is 0%, it is ON/OFF control: if there is a value for P, is proportional control.
- Factory default : ON/OFF control (P : 0%)
- The conversion of temperature unit (°C / °F) [Unb]**
  - By choosing °C or °F on temperature unit setting parameter, [Unb] conversion is available.
  - After choosing a temperature unit, LED is ON.
  - Factory default : °C
- Cooling / Heating operation**
  - Generally there are two ways to control temperature, one(heat-function) is to heat when PV is getting down(heater). The other(cool-function) is to cool when PV is getting high(refrigerator).
  - Setting range: HEt(Heat) / Col(Cool) (factory default : HEt)
- Display a PV deviation**
  - It displays the deviation between the PC and the SV.
  - When the PV is higher than the SV(PV > SV+2°C), Δ is lighted.
  - When the PV is lower than the SV(PV < SV-2°C), ▽ is lighted.
  - When the deviation of the PV is within ±2°C, □ is lighted.
- High/low limit setting for using temperature**
  - Set a high/low limit of temperature and the set range is within using range.
  - If setting a high-limit of temperature on [H5C], it is a high-limit SV
  - If setting a low-limit of temperature on [L5C], it is a low-limit SV.
  - L.SC ≤ SV ≤ H.SC. In case of L.SC=SV=H.SC, the output is OFF.
  - If change L.SC and H.SC, the using range and proportional band also are changed.
- Error display**
  - If Error occurs during the operation, error signal flickers every one sec.

Display	Description
aPn	When the input sensor is not connected or its wire is cut. (Normal operation after connecting a sensor)
LLL	When the measured input temperature is lower than input range of the sensor.
HHH	When the measured input temperature is higher than input range of the sensor.

- When error [aPn] / [LLL] / [HHH] occur After the causes of error is solved, it operates normally.
- The priority of 'Error' display : aPn → HHH, LLL
- Output setting for error [oEr]**
  - For error, the statue of output is set by [oEr] of setting group 2.
  - For setting OFF: Output is always OFF for error.
  - For setting ON: Output is always ON for error.
  - Factory default : OFF
- Lock setting [LoC]**
  - This function limits the change of parameters on each setting group. It can be set setting group 2.
  - For setting [LC1], changing the parameter, "Setting group 2", is not available.
  - For setting [LC2], changing the parameter, "Setting group 1 + Setting group 2", is not available.
  - For setting [LC3], changing the parameter, "Setting group 1 + Setting group 2 + SV setting parameter", is not available.
  - For setting [oFF], Lock off for all setting group

**Factory default**

Parameter	Description	Setting range	Unit	Factory default
P	Proportional band	0 ~ 100	%	0
t	The period of proportional control	1 ~ 120	sec	10
r5t	The correction value of offset for proportional control	0 ~ 100	%	50
HY5	Hysteresis for ON/OFF control	2 ~ 100	°C	2
Inb	Input correction value	-30 ~ 30	°C	0

Parameter	Description	Setting range	Unit	Factory default
Inb	Temperature sensor	ECR, JIC, PEH, PEL	-	JIC
H5C	High-limit value of using temperature	See "Input specifications and range"	°C	400
L5C	Low-limit value of using temperature	See "Input specifications and range"	°C	0
oFt	Cooling/Heating operation	HEt ↔ Col	-	HEt
oEr	Output for error	oN ↔ oFF	-	oFF
Unb	Temperature unit	°C ↔ °F	-	°C
LoC	Lock	oFF, LC1, LC2, LC3	-	oFF

**Caution for using**

- Installation environment
  - It shall be used indoor.
  - Altitude Max. 2000m.
  - Pollution Degree 2.
  - Installation Category II.
- Please install power switch or circuit-breaker in order to cut power supply off.
- The switch or circuit-breaker should be installed near by users.
- Do not use this product as Volt-meter or Ampere-meter, this is a temperature controller.
- Be sure to use compensating wire when extends wire from controller to thermocouple, otherwise the temperature deviation will be occurred at the part where wires are connected to each other.
- In case of using RTD sensor, 3wire type must be used. If you need to extend the line, 3wires must be used with the same thickness as the line. It might cause the deviation of temperature if the resistance of line is different.
- In case of making power line and input signal line closely, line filter for noise protection should be installed at power line and input signal line should be shielded.
- Keep away from the high frequency instruments. (High frequency welding machine & sewing machine, large capacity SCR controller)

It may cause malfunction if above instructions are not followed.

**Main products**

- COUNTER
- TIMER
- TEMPERATURE CONTROLLER
- PANEL METER
- TACHO LINE SPEED/PULSE METER
- DISPLAY UNIT
- PROXIMITY SENSOR
- PHOTOELECTRIC SENSOR
- FIBER OPTIC SENSOR
- PRESSURE SENSOR
- ROTARY ENCODER
- SENSOR CONTROLLER
- POWER CONTROLLER
- STEPPING MOTOR & DRIVER & CONTROLLER
- LASER MARKING SYSTEM(CO2, Nd:YAG)

**Autonics Corporation**  
http://www.autonics.com

**Satisfiable Partner For Factory Automation**

**HEADQUARTERS :**  
41-5, Yongdang-ri, Ulsang-eup, Yongsan-si, Gyeongnam, 626-847, Korea

**INTERNATIONAL SALES :**  
Bldg. 402 3rd Fl., Bucheon Techno Park, 193, Yagdae-dong, Wornim-gu, Bucheon-si, Gyeonggi-do, 420-734, Korea  
TEL: 82-32-610-2730 / FAX: 82-32-329-0728  
E-mail : sales@autonics.net

EP-KE-03-0310A