

Autonics

**INDUCTIVE PROXIMITY SENSOR
(CYLINDRICAL METAL DC CONNECTOR TYPE)
PRCM SERIES**

M A N U A L



Thank you very much for selecting Autonics products.
For your safety, please read the following before using.

Caution for your safety

*Please keep these instructions and review them before using this unit.

*Please observe the cautions that follow;

Warning Serious injury may result if instructions are not followed.

Caution Product may be damaged, or injury may result if instructions are not followed.

*The following is an explanation of the symbols used in the operation manual.

Caution: Injury or danger may occur under special conditions.

Warning

- Highly affective equipment to human or properties. (Nuclear power control, medical instrument, vehicles, train, airplane, combustion apparatus, entertainment etc. and if want to use in safety system, be sure to install fail safety device.
It may result in serious damage, fire or human injury.
- Do not connect power directly without load.
It may result in damage to inner components or burn them out.

Caution

- Do not use this unit in place where there is flammable, explosive gas, chemical or strong alkalis, acids.
It may cause a fire or explosion.
- Do not impact on this unit.
It may result in malfunction or damage to the product.
- Do not apply AC power and observe specification rating.
It may result in serious damage to the product.

Ordering information

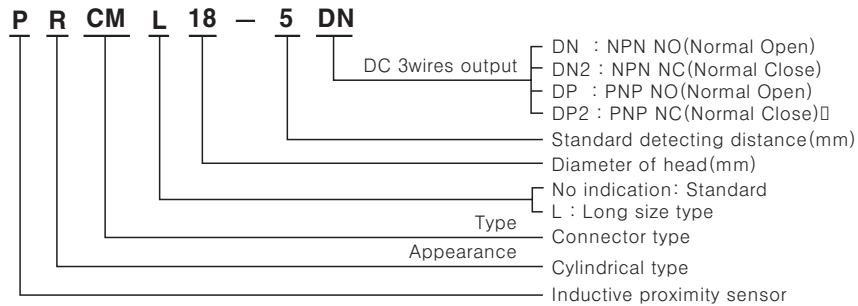

Control output diagram & Load operating

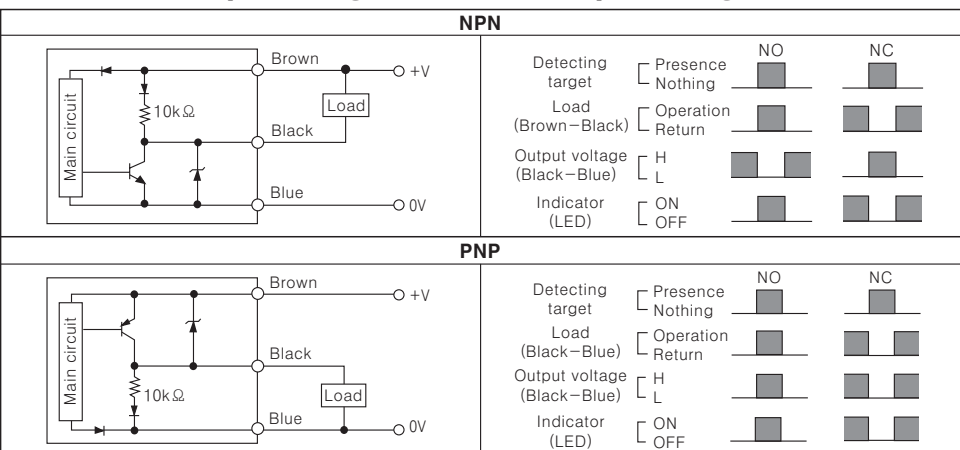

*The above specification are changeable without notice anytime.

Specifications

Model	PRCM12-2DN PRCM12-2DP PRCM12-2DN2 PRCM12-2DP2	PRCM12-4DN PRCM12-4DP PRCM12-4DN2 PRCM12-4DP2	PRCM18-5DN PRCM18-5DP PRCM18-5DN2 PRCM18-5DP2	PRCM18-8DN PRCM18-8DP PRCM18-8DN2 PRCM18-8DP2	PRCM30-10DN PRCM30-10DP PRCM30-10DN2 PRCM30-10DP2	PRCM30-15DN PRCM30-15DP PRCM30-15DN2 PRCM30-15DP2
Detecting distance	2mm ±10%	4mm ±10%	5mm ±10%	8mm ±10%	10mm ±10%	15mm ±10%
Hysteresis	Max. 10% of detecting distance					
Standard detecting target	12×12×1mm (Iron)		18×18×1mm (Iron)	25×25×1mm (Iron)	30×30×1mm (Iron)	45×45×1mm (Iron)
Setting distance	0 to 1.4	0 to 2.8	0 to 3.5	0 to 5.6	0 to 7	0 to 10.5
Power supply (Operating voltage)	12-24VDC (10-30VDC)					
Current consumption	Max. 10mA					
Response frequency	800Hz	400Hz	350Hz	200Hz	250Hz	100Hz
Residual voltage	Max. 1.5V					
Affection by Temp.	±10% max. of detecting distance at +20°C within temperature range of -25 to +70°C					
Control output	Max. 200mA					
Insulation resistance	Min. 50MΩ (500VDC)					
Dielectric strength	1500VAC 50/60Hz for 1 minute					
Vibration	1mm amplitude at frequency of 10 to 55Hz in each of X, Y, Z directions for 2 hours					
Shock	500m/s ² (50G) X, Y, Z directions for 3 times					
Indicator	Operating indicator : Red LED					
Ambient temperature	-25 to +70°C (non-freezing condition)					
Storage temperature	-30 to +80°C (non-freezing condition)					
Ambient humidity	35 to 95%RH					
Protection circuit	Reverse polarity protection, surge protection, overload & short circuit protection					
Protection	IP67(IEC specification)					
Weight	Approx. 26g	PRCM : Approx. 49g PRCML : Approx. 73g	PRCM : Approx. 134g PRCML : Approx. 169g			

Dimensions

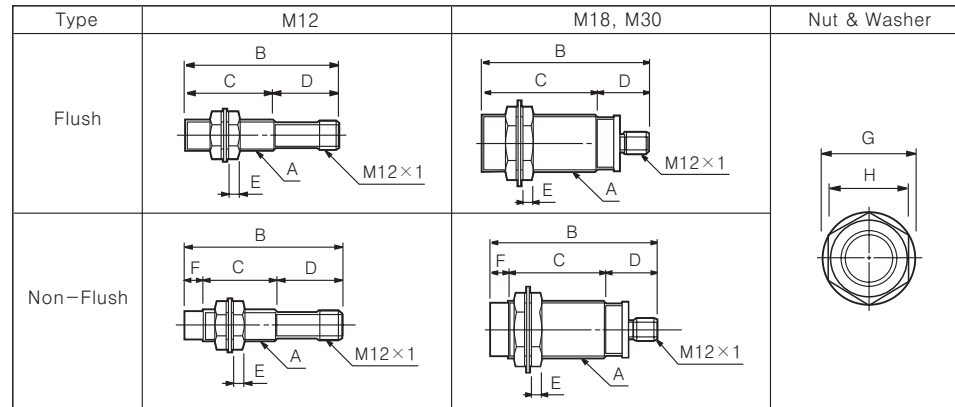

Type	Model	A	B	C	D	E	F	G	H
Flush	M12 PRCM	M12×1	54.8	31.5	23.3	4	—	20.5	17
	M12 PRCML	M12×1	52.8	29	23.8	4	—	29	24
	M18 PRCM	M18×1	85.8	62	23.8	4	—	29	24
	M18 PRCML	M18×1	85.8	62	23.8	4	—	29	24
	M30 PRCM	M30×1.5	62.8	38	24.8	5	—	42	35
	M30 PRCML	M30×1.5	84.8	60	24.8	5	—	42	35
Non-Flush	M12 PRCM	M12×1	54.8	24.5	23.3	4	7	20.5	17
	M18 PRCM	M18×1	52.8	19	23.8	4	10	29	24
	M18 PRCML	M18×1	85.8	52	23.8	4	10	29	24
	M30 PRCM	M30×1.5	62.8	28	24.8	5	10	42	35
	M30 PRCML	M30×1.5	84.8	50	24.8	5	10	42	35

•CID3-□

•CLD3-□

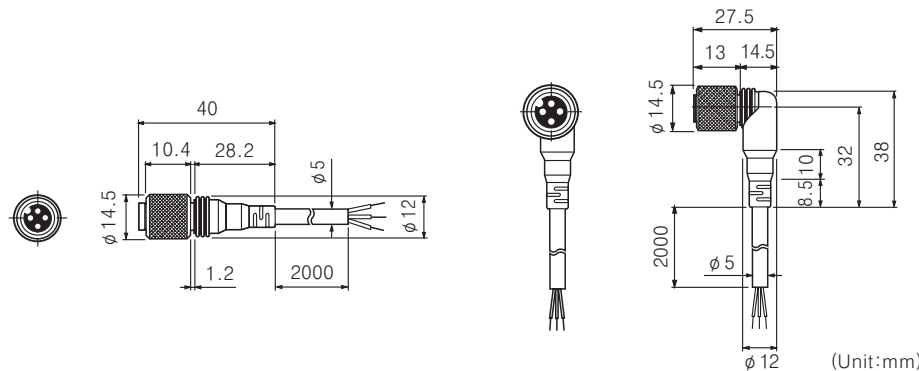

Mutual-interference & Influence by surrounding metals

Mutual-interference

When plural proximity sensors are mounted in a close row, malfunction of sensor may be caused due to mutual interference. Therefore, be sure to provide a minimum distance between the two sensors, as below charts.

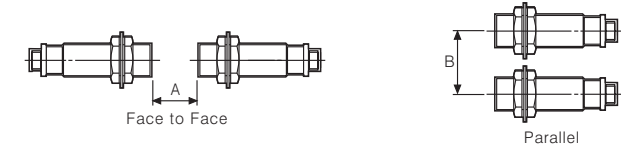

Influence by surrounding metals

When sensors are mounted on metallic panel, it must be prevented sensors from being affected by any metallic object except target, therefore, be sure to provide a minimum distance as below chart.

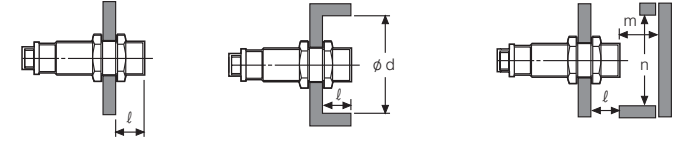

(Unit:mm)

Model Item	PRCM12-2D□	PRCM12-4D□	PRCM(L)18-5D□	PRCM(L)18-8D□	PRCM(L)30-10D□	PRCM(L)30-15D□
A	12	24	30	48	60	90
B	24	36	36	54	60	90
ℓ	0	11	0	14	0	15
∅d	12	36	18	54	30	90
m	6	12	15	24	30	54
n	18	36	27	54	45	90

Setting distance

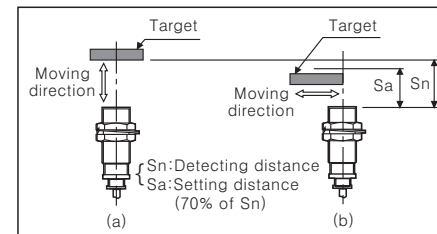

•Detecting distance can be changed by the shape, size or material of the target. Therefore please check the detecting distance like (a), then pass the target within range of setting distance (Sa).

•Setting distance (Sa)
= Detecting distance (Sn) × 70%
ex) PRCM30-10DN (See ordering information)
Setting distance (Sa) = 10mm × 0.7 = 7mm

Caution for using

- This equipment shall not be used outdoors or beyond specified temperature range.
 - Do not load over than tensile strength of cord. (∅4:30N max., ∅5:50N max.)
 - Do not use the same conduit with cord of this unit and electric power line or power line. Also avoid the same connection.
 - Do not put overload to tighten nut, please use washer for tightening.
Note1) Allowable strength may be different by the length of head. As see the picture, allowable tightening strength of front part and rear part are in (Chart 1). Rear part includes head nut as like picture.
Note2) (Chart1) is for using washer.
 - Please check the voltage changes of power source in order not to excess rating power input.
 - Do not use this unit during transient time(80ms) after apply power.
 - It might result in damage to this product, if use automatic transformer. So please use insulated transformer.
 - Please make wire short as much as possible in order to avoid noise.
 - Be sure to cable as indicated specification on this product. If use wrong cable or bended cable, it shall not maintain the water-proof.
 - It is possible to extend cable with over 0.3mm² and max. 200m.
 - If the target is plated, the operating distance can be changed by the plating material.
 - It may result in malfunction by metal particle on product.
 - If there are machines(DC type bulb etc), which occurs big surge around this unit, please install the Varistor or absorber to source of surge, even though there is built-in surge absorber in this unit.
 - If connect the load with big inrush current(DC type bulb) to this unit, the big inrush current will flow due to the initial resistance is low. If the current flows, the resistance of load will be bigger, then it will return to standard current. In this case, proximity sensor might be damaged by inrush current. If you use DC type bulb, please connect extra relay or resistance in order to protect proximity sensor from.
 - If make a transceiver close to proximity sensor or wire connection, it may cause malfunction.
- *It may cause malfunction if above instructions are not followed.**

Model	Strength	Size	Front	
			Torque	Torque
PRCM12 Series	Flush	13mm	65kgf-cm	120kgf-cm
PRCM18 Series	Flush	7mm	150kgf-cm	150kgf-cm
PRCM30 Series	Flush	26mm	500kgf-cm	800kgf-cm
	Non-flush	12mm	500kgf-cm	800kgf-cm

(Chart1)

Main products

- COUNTER
- TIMER
- TEMPERATURE CONTROLLER
- PANEL METER
- TACHO/LINE SPEED/PULSE METER
- DISPLAY UNIT
- PROXIMITY SENSOR
- PHOTOELECTRIC SENSOR
- FIBER OPTIC SENSOR
- PRESSURE SENSOR
- ROTARY ENCODER
- SENSOR CONTROLLER
- POWER CONTROLLER
- STEPPING MOTOR & DRIVER & CONTROLLER
- LASER MARKING SYSTEM(CO₂, Nd:YAG)

Autonics Corporation
http://www.autonics.com

Satisfiable Partner For Factory Automation

HEADQUARTERS :
41-5, Yongdang-ri, Ungsang-eup, Yangsan-si, Gyeongnam, 626-847, Korea

INTERNATIONAL SALES :
Bldg. 402 3rd Fl., Bucheon Techno Park, 193, Yakdae-dong, Wonmi-gu, Bucheon-si, Gyeonggi-do, 420-734, Korea
TEL: 82-32-329-0722 / FAX: 82-32-329-0728
E-mail : sales@autonics.net