

Autonics

**TRANSMISSION COUPLER
PET18-5**

M A N U A L



Thank you very much for selecting Autonics products.
For your safety, please read the following before using.

Caution for your safety

※Please keep "Caution for your safety" to avoid accidents or damages as using it correctly.

※The meaning of 'Warning' and 'Caution' is as follows:

Warning In case a serious injury or dead may be occurred.

Caution In case a little injury or a damage of this unit may be occurred.

※The meaning of the mark on the product and manual is as follows:
⚠ is a caution mark for danger in special condition.

Warning

- In case of using this unit with machineries(Nuclear power control, medical equipment vehicle, train, airplane, combustion apparatus, entertainment or safety device etc), it requires installing fail-safe device, or contact us for information on type required.**

It may result in serious damage, fire or human injury.

Caution

- Do not use this unit in place where there are flammable, explosive gas, chemical or strong alkalis, acids.**
It may cause a fire or explosion.
- Do not impact on this unit.**
It may result in malfunction or damage to the product.

Dimensions

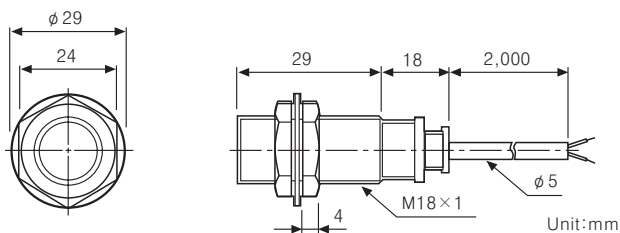

※The above specification are changeable without notice anytime.

Specifications

Model	PET18-5		
Transmitting distance	5mm ±10%		
Setting distance	1 to 4.5mm		
Response time	Max. 1ms		
Insulation resistance	Min. 50MΩ (500VDC)		
Dielectric strength	1500VAC 50/60Hz for 1minute		
Vibration	1mm amplitude at frequency of 10 to 55Hz in each of X, Y, Z directions for 2 hours		
Shock	500m/s ² (50G) X, Y, Z directions for 3 times		
Ambient temperature	-25 to +70°C (non-freezing condition)		
Ambient humidity	35 to 95%RH		
Protection	IP67(IEC standard)		
Weight	Approx. 121g		
Application of proximity sensor	PR18-5DN PR18-5DP PR18-5DN2 PR18-5DP2 PRW18-5DN PRW18-5DN2 PRW18-5DP PRW18-5DN2 PRW18-5DP2	PRCM18-5DN PRCM18-5DP PRCM18-5DN2 PRCM18-5DP2 PRWL18-5DN PRWL18-5DN2 PRWL18-5DP PRWL18-5DN2 PRWL18-5DP2	PRL18-5DN PRL18-5DP PRL18-5DN2 PRL18-5DP2 PRCML18-5DN PRCML18-5DP PRCML18-5DN2 PRCML18-5DP2

Connections

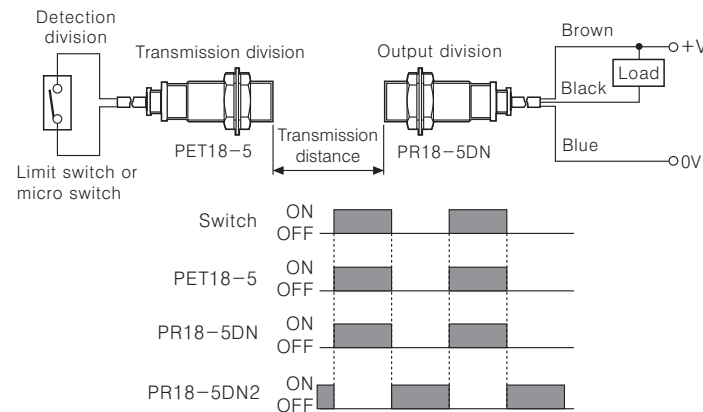

Principle of operation

It is transmitted ON/OFF signal by electromagnetic coupling character which is accured between the proximity sensor's coil and the coupler's coil. When the limit switch connected with the coupler turn on within magnetic field of the proximity sensor, induced current is occurred in the coupler. The proximity sensor turn on because the proximity sensor's current reduces by induced current.

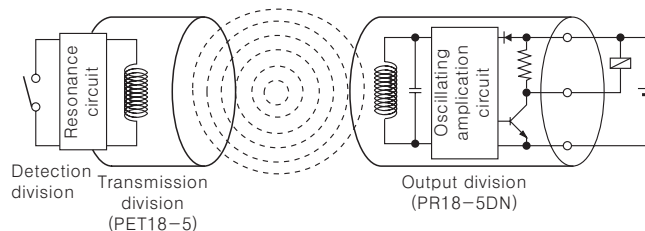

Detecting characteristics

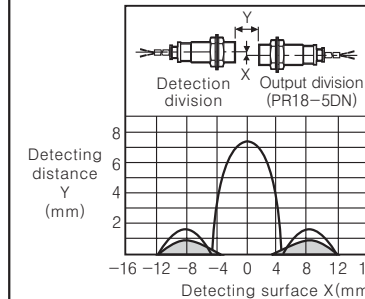

●Even if the limit switch or the micro switch turns off, the proximity sensor can detect the metal case of the coupler, the proximity sensor and the coupler must be installed within safe application range. (□)

Caution for using

- This equipment shall not be used outdoors or beyond specified temperature range.
- Do not load over than tensile strength(30N) of cord.
- Do not use the same conduit with cord of this unit and electric power line or power line. Also avoid the same connection.
- Do not put overload to tighten nut, please use washer for tightening.
 - Allowable strength is different by the length from the line of the head. Allowable screw torque at front and rear part is 150kgf·cm.
 - Above allowable screw torque is the value when the washer is used.
- Please make wire short as much as possible in order to avoid noise.
- Be sure to cable as indicated specification on this product. If use wrong cable or bended cable, it shall not maintain the water-proof.
- It is available to extend to max. 5m cable with thicker than 0.3mm² diameter.
- It may cause malfunction when putting transeiver near by proximity snesor and the cable.
- Contact switch at the detecting part shouldn't have a leakage current when it is off.
- Contact switch(Limit switch or Micro switch etc.) should be max. 300mΩ of contact resistant and min. 10MΩ of open resistant.
- It may cause malfunction if metal dust etc. is put on the detecting surface since using inductive proximity sensor as output part.
- It is available to transmit a signal even though there is the material like plastic or mirror etc.
- Please set it up in A area of below chart when installing on a body of revolution.

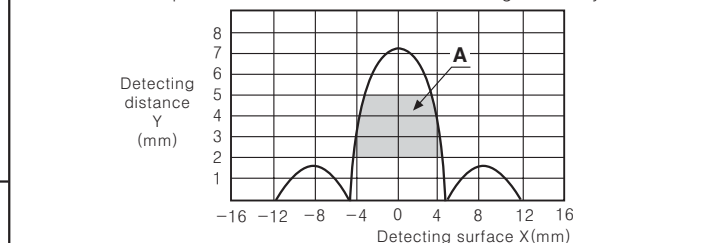
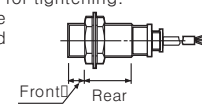

※It may cause malfunction if above instructions are not followed.

Main products

- COUNTER
- TIMER
- TEMPERATURE CONTROLLER
- PANEL METER
- TACHO/LINE SPEED/PULSE METER
- DISPLAY UNIT
- PROXIMITY SENSOR
- PHOTOELECTRIC SENSOR
- FIBER OPTIC SENSOR
- PRESSURE SENSOR
- ROTARY ENCODER
- SENSOR CONTROLLER
- POWER CONTROLLER
- STEPPING MOTOR & DRIVER & CONTROLLER
- LASER MARKING SYSTEM

Autonics Corporation
<http://www.autonics.com>

■ HEAD QUARTER :
 41-5, Yongdang-ri, Ungsang-eup, Yangsan-si, Gyeongnam, Korea 626-847

■ INTERNATIONAL SALES :
 512 Ansung B/D, 410-13, Shindorim-dong, Guro-gu, Seoul, Korea 152-070
 TEL:82-2-2679-6585 / FAX:82-2-2679-6556
 E-mail : sales@autonics.net