

# Autonics Motor Driver(2-Phase microstepping driver) MD2U-MD20

M A N U A L



Thank you very much for selecting Autonics products.  
For your safety, please read the following before using.

## Caution for your safety

- \*Please keep these instructions and review them before using this unit.
- \*Please observe the cautions that follow:
- Warning** Serious injury may result if instructions are not followed.
- Caution** Product may be damaged, or injury may result if instructions are not followed.
- \*The following is an explanation of the symbols used in the operation manual.
- Caution:**Injury or danger may occur under special conditions.

## Warning

- In case of using this unit with machinery(Nuclear power control, medical equipment, vehicle, train, airplane, combustion apparatus, entertainment or safety device etc), it is required to install fail-safe device. (or contact us for information on type required.)  
It may cause serious human injury or a fire and damage to product.
- Installation, connection, operation, control, maintenance should be carried out by person who has been qualified.  
It may cause a fire, electric shock or human injury.
- Please use DC power with reinforced insulating the primary and secondary part for the DC power product.  
It may give an electric shock.
- Please install this unit after considering counterplan against power failure.  
It may cause human injury or damage to product by releasing holding torque of motor.
- Do not use this unit outdoors or place where there are flammable, corrosive gas, water and too much vibration etc.  
It may cause a fire or give an electric shock.
- Do not put finger or any object into this product.  
It may cause a fire or give an electric shock.
- Do not disassemble and modify this unit, when it is required, please contact us.  
It may cause a fire or give an electric shock, damage to product.
- Please use the adjuster with insulated screw driver.  
It may give an electric shock.

## Caution

- Do not move, install, connect or inspect during the operation.  
It may give an electric shock.
- Power input voltage must be used within rated specification and power line should be over than AWG NO. 18(0.75mm<sup>2</sup>).  
It may cause a fire or give an electric shock.
- Please check the connection before supplying the power.  
It may cause a fire or give an electric shock, damage to product.
- When connecting the unit with power, please install current breaker.  
It may cause a fire.
- Please turn off the power when power is failed.  
It may cause human injury or damage to product due to sudden movement when recovering power failure.
- Please supply power after checking control input signal.  
It may cause a burn due to high temperature in surface.
- The emergency stop is needed during the operation.  
It may cause human injury or damage to product.
- Please apply power after checking control input signal.  
It may cause human injury or damage to product by sudden movement.
- Do not turn on the HOLD OFF signal input while it is maintaining vertical position.  
It may cause human injury or damage to product by releasing holding torque of motor.
- Please install a safety device when it is required to remain the vertical position after turning off the power.  
It may cause human injury or damage to product by releasing holding torque of motor.
- Please check if HOLD OFF signal input is ON when it is required to set the output manually.  
It may cause human injury by sudden movement.
- Please stop this unit when mechanical problem occurred.  
It may cause a fire or human injury.
- Do not touch the terminal when measuring insulation resistance and testing insulation dielectric strength.  
It may give an electric shock.
- Please observe rated specification.  
It may cause human injury, electric shock or damage to product.
- In cleaning the unit, do not use water or an oil-based detergent.  
It may cause a fire or give an electric shock.
- Please separate as industrial waste when disusing this unit.
- Please use the designated 2-phase stepping motor in output part.  
It may cause a fire or damage to product.

\*The above specifications are changeable at anytime without notice.

## Features

- Unipolar constant current drive type.
- Available low-speed revolution and precision control with a microstep drive (Resolution : 1, 2, 4, 5, 8, 10, 16, 20 of microstep)
- Able to adjust RUN current and STOP current of motor.
- Photocoupler input insulation method to minimize the effects from external noise.
- Power supply : 24-35VDC

## Specifications

Model	MD2U-MD20	
Power supply	24-35VDC	
Allowable voltage range	80 to 120% of the rating voltage	
Output current (1)	3A[Max.]	
RUN current (2)	0.5 ~ 2A/Phase	
Resolution	1, 2, 4, 5, 8, 10, 16, 20 of microstep	
Input pulse spec. (2)	Pulse width	Min. 6μs (Duty 50%)
	Pulse interval	
	Rising/falling time	Max. 0.5μs
	Pulse input voltage	[H] 4-8VDC, [L] 0-0.5VDC
	Max. input pulse frequency (3)	Max. 40kpps
Dielectric strength	1000VDC 60Hz for 1 minute (Between electrification and non-electrification parts)	
Insulation voltage	Min. 200MΩ (Based on 500VDC of electrification and non-electrification parts)	
Noise resistance	±500V the square wave noise (pulse width:1μs) by the noise simulator	
Vibration	1.5mm amplitude at frequency of 10 ~ 55Hz in each of X, Y, Z directions for 2 hours	
Shock	300m/s <sup>2</sup> (Approx. 30G) in X, Y, Z directions for 3 times	
Ambient temperature	0 ~ 50°C (at non-freezing status)	
Ambient humidity	35 ~ 85%RH (at non-dew status)	
Storage temperature	-20 ~ 60°C (at non-freezing status)	
Unit weight	Approx. 180g	

- (1) Ambient temperature is 25°C and ambient humidity is 55%RH.
- (2) The max. value of RUN current is based on RMS value in accordance with frequency of running motor, peak power can be changed by load fluctuation.
- (3) It can be changed by pull-out frequency and max. slewing frequency range.

## Dimensions

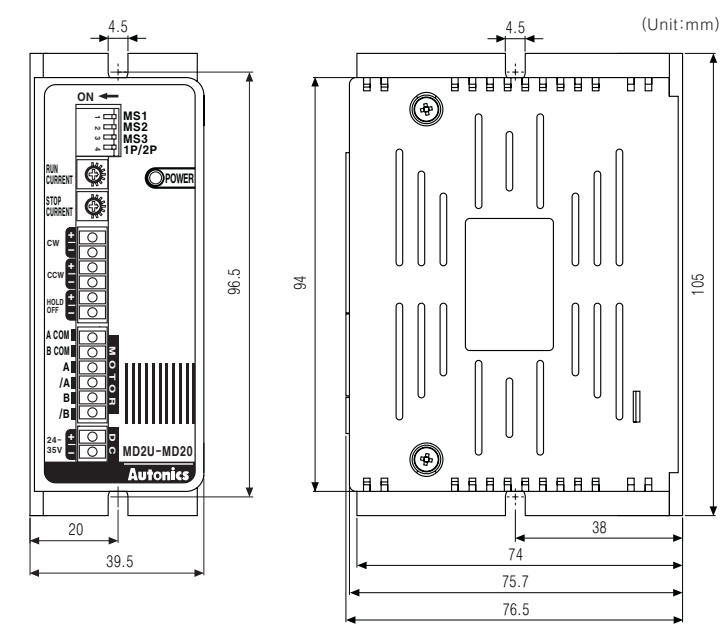

## Time charts

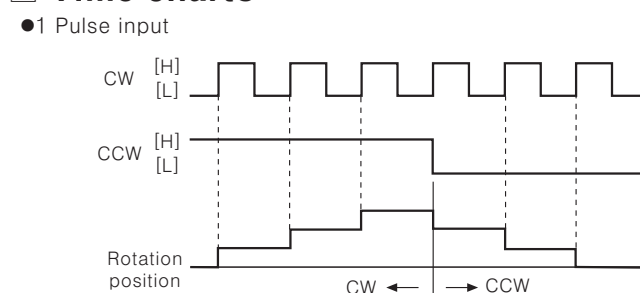

## ●2 Pulse input

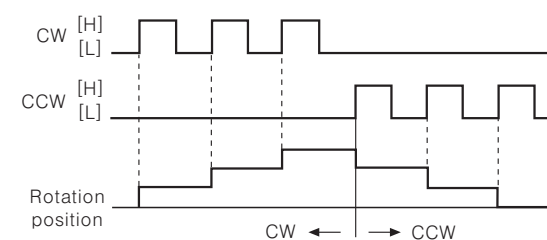

## Input · Output diagram

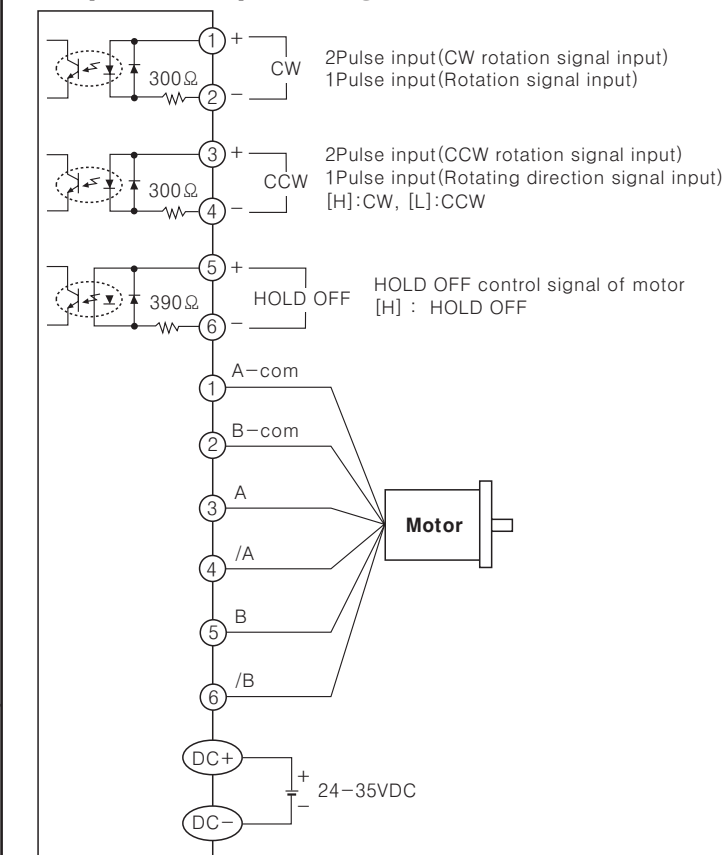

## Function

### Function switch

No.	Name	Function	Switch position			
			ON		OFF	
1	MS1	Microstep set 1	MS1	MS2	MS3	Resolution
			ON	ON	ON	1(Full-step)
			ON	ON	OFF	2 division
2	MS2	Microstep set 2	ON	OFF	ON	4 division
			OFF	ON	ON	8 division
			OFF	ON	OFF	10 division
3	MS3	Microstep set 3	OFF	OFF	ON	16 division
			OFF	OFF	OFF	20 division
4	1P/2P	Selectable RUN mode	1 Pulse method		2 Pulse method	

### ●MS1 / MS2 / MS3

- Selectable microstep resolution of driver by switch.
- Selectable division 1(Full), 2, 4, 5, 8, 10, 16, 20 by switch.
- It is able to input max. input pulse frequency up to 40kpps.
- The calculation formula of rotation angle depending on resolution is as below.

$$\text{Rotation angle per pulse of 2-phase} [^\circ] = \frac{1.8^\circ \text{ or } 0.9^\circ}{\text{Resolution}}$$

### ●1P / 2P

- Selectable RUN mode switch
- 1P type : Pulse signal input for CW, rotating direction signal input for CCW.
- 2P type : CW rotation signal input for CW, CCW rotation signal input for CCW.

## Setting of RUN current

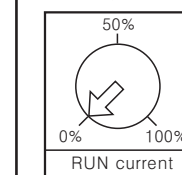

- RUN current is phase current provided to 2-phase stepping motor.
- RUN current is set by variable resistance ratio within 0-100%.
- It should be used within the rated current of motor, or it may cause overheating, step-out and torque can be lowered.
- Setting range of RUN current 0.5-2.0A(Default value 1.4A)
- Measure the voltage of CT- and CT+ in front of RUN current adjuster during the operation(Under 2kpps) to set the RUN current. (Using DC voltmeter)  
Ex) Measuring voltage(3V) × 2 / 3=2A(Motor excitation current)

## Setting of STOP current

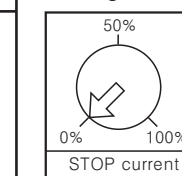

- STOP current is phase current provided to 2-phase of stepping motor to be stopped.
- STOP current is set by variable resistance ratio within 0-100%.
- STOP current is changed because inner coil impedance according to motor.
- It is operated when HOLD OFF signal is [L] and auto Current Down function is not available when it is [H], because current provided to each phase is cut off.
- Setting range of Stop current : 20-70% of RUN current (Default value approx. 0.6A)

## Failure diagnosis and management

- If motor does not rotate
  - Check the connection of controller and driver and pulse input specification. (Voltage, width)
  - Check the input pulse method and connected method is same.
  - Check pulse and direction signal is connected correctly for 1P input.
- If motor rotates as a reverse direction.
  - Check input pulse connection of CW and CCW is correct for 2P input.
  - In case of 1P input, it is CW rotation when the input is [H] in CCW and it is CCW rotation for [L].
- If motor does not work properly.
  - Check the connection of driver and motor.
  - Check the pulse input specification(Voltage · width) of driver.
  - Check output current for current adjusting S/W and current for motor operation as correct.

## Caution for using

- Caution for signal input
    - When using the 2 pulse input method, do not input CW and CCW at the same time, or it may cause malfunction.
    - In case, the signal input supply is higher than rated supply expressed on the specification, please connect the additional resistance to external part. (Connect 3kΩ of resistance when applying 24V of power)
  - Caution for setting the RUN and STOP current  
RUN current must be set under a rated current of the motor because motor emits heat too much when a RUN current is set over a rated current of the motor.
  - Caution for wiring
    - Use Twist pair(Over 0.2mm<sup>2</sup>) for the signal wire should be shorter than 2m.
    - Please use an electric wire is thicker than the motor lead when lengthening the motor wire connection.
    - Please leave a space over 10cm between a signal wire connection and power wire.
  - Caution for installation
    - Keep the heat sink as close as possible to metal panels and place the unit in well-ventilated area in order to increase heat protection efficiency of heat sink.
    - Heat generation may occur on drivers depending on installation environments. Place the unit with keeping the heat sink under 80°C.
  - Caution of using function switch  
When the input switch is changed to 2P input method during the operation, it may be danger as the motor is rotated reversely. Please do not change the input signal method and resolution during the operation.
  - Motor vibration and noise can be occurred in specific frequency period.
    - Motor vibration and noise can be lowered by change motor installation or attach damper.
    - Use the unit in a range without vibration and noise range by RUN speed adjustment or microstep.
  - Installation environment
    - It shall be used indoor
    - Altitude Max. 2000m
    - Pollution Degree 2
    - Installation Category II
- \*It may cause malfunction if above instructions are not followed.**

## Major products

- Proximity sensors
- Fiber optic sensors
- Rotary encoders
- Temperature controllers
- Temperature/Humidity transducers
- Power controllers
- Recorders
- Tachometer/Pulse(Rate) meters
- Panel meters
- Indicators
- Signal converters
- Counters
- Timers
- Display units
- Graphic/Logic panel
- Stepping Motors & Drivers
- Area sensors
- Pressure sensors
- Sensor controllers
- Switching power supply

**Autonics Corporation**  
http://www.autonics.com

**Satisfiable Partner For Factory Automation**

■ HEAD QUARTERS :  
41-5, Yongdang-dong, Yangsan-si, Gyeongsang, 626-847, Korea

■ OVERSEAS SALES :  
Bldg. 402 3rd Fl., Bucheon Techno Park, 193, Yakdae-dong, Wornmi-gu, Bucheon-si, Gyeonggi-do, 420-734, Korea  
TEL:82-32-610-2730 / FAX:82-32-329-0728  
■ E-mail : sales@autonics.com

The proposal of product improvement and development : Product@autonics.com