

E50SP Series

Diameter ϕ 50mm Shaft type Incremental Rotary encoder

■ Features

- Light plastic body
- Suitable for measuring Angle, Position, Revolution, Speed, Acceleration and Sensing distance
- Power supply : 5VDC, 12-24VDC \pm 5%
- Cost-effective

■ Applications

- Various tooling machinery, packing machine and general industrial machinery etc.



⚠ Please read "Caution for your safety" in operation manual before using.

■ Ordering information (Former name : ENB)

E50S	8	P	-	600	-	3	-	N	-	24	-	
Series	Shaft diameter	External material	Pulse/1Revolution	Output phase	Control output	Power supply	Cable					
Diameter ϕ 50mm, shaft type	6 : ϕ 6mm 8 : ϕ 8mm	Plastic	Refer to resolution	2:A, B 3:A, B, Z 4:A, \bar{A} , B, \bar{B} 6:A, \bar{A} , B, \bar{B} , Z, \bar{Z}	T:Totem pole output N:NPN open collector output V:Voltage output L:Line driver output(※)	5 :5VDC \pm 5% 24:12-24VDC \pm 5%	No mark:Normal type (※) C:Cable outgoing connector type					

※Standard:E50S8P-**PULSE**-3-N-24

※Standard : A, B, Z ※The power of Line driver is only for 5VDC

※Cable length : 250mm

■ Specifications

Item	Diameter ϕ 50mm shaft type of Incremental rotary encoder		
Resolution(P/R)	(Note1)	*1, *2, *5, 10, *12, 15, 20, 23, 25, 30, 35, 40, 45, 50, 60, 75, 100, 120, 125, 150, 192, 200, 240, 250, 256, 300, 360, 400, 500, 512, 600	
Electrical specification	Output phase	A, B, Z phase(Line driver : A, \bar{A} , B, \bar{B} , Z, \bar{Z} phase)	
	Phase difference of output	Output between A and B : $\frac{T}{4} \pm \frac{T}{8}$ (T=1cycle of A phase)	
	Control output	Totem pole output	• Low \Rightarrow Load current:Max. 30mA, Residual voltage : Max. 0.4VDC • High \Rightarrow Load current:Max. 10mA, Output voltage(Power supply 5VDC):Min. (Power supply-2.0)VDC, Output voltage(Power supply 12-24VDC):Min. (Power supply-3.0)VDC
		NPN open collector output	Load current : Max. 30mA, Residual voltage : Max. 0.4VDC
		Voltage output	Load current : Max. 10mA, Residual voltage : Max. 0.4VDC
		Line driver output	• Low \Rightarrow Load current : Max. 20mA, Residual : Max. 0.5VDC • High \Rightarrow Load current : Max. -20mA, Output voltage : Min. 2.5VDC
	Response time (Rise/Fall)	Totem pole output	Max. 1 μ s
		NPN open collector output	Max. 1 μ s
		Voltage output	Max. 1 μ s
		Line driver output	Max. 0.5 μ s
Max. Response frequency	180kHz		
Power supply	• 5VDC \pm 5% (Ripple P-P:Max. 5%) • 12-24VDC \pm 5% (Ripple P-P:Max. 5%)		
Current consumption	Max. 80mA(disconnection of the load), Line driver output:Max. 50mA(disconnection of the load)		
Insulation resistance	Min. 100M Ω (at 500VDC mega between all terminals and case)		
Dielectric strength	750VAC 50/60Hz for 1 minute (Between all terminals and case)		
Connection	Cable outgoing type, 200mm cable outgoing connector type		
Mechanical specification	Starting torque	Max. 100gf \cdot cm (0.01N \cdot m)	
	Rotor inertia	Max. 40g \cdot cm ² (4 \times 10 ⁻⁶ kg \cdot m ²)	
	Shaft loading	Radial : Max. 2kgf, Thrust : Max. 1kgf	
	Max. allowable revolution	(Note2)	5000rpm
Vibration	1.5mm amplitude at frequency of 10 ~ 55Hz in each of X, Y, Z directions for 2 hours		
Shock	Max. 75G		
Ambient temperature	-10 ~ 70 $^{\circ}$ C (at non-freezing status), Storage:-25 ~ 85 $^{\circ}$ C		
Ambient humidity	35~85%RH, Storage: 35~90%RH		
Protection	IP50 (IEC standard)		
Cable	ϕ 5mm, 5P, Length : 2m, Shield cable (Line driver output : ϕ 5mm, 8P)		
Accessory	ϕ 8mm coupling standard, ϕ 6mm coupling (Sold separately), Bracket		
Unit weight	Approx. 235g		

※ (Note1) * pulse is only for A, B phase (Line Driver output is for A, \bar{A} , B, \bar{B} phase)

※ (Note2) Max. allowable revolution \geq Max. response revolution $\left[\text{Max. response resolution (rpm)} = \frac{\text{Max. response frequency}}{\text{Resolution}} \times 60 \text{ sec} \right]$

Incremental ϕ 50mm Shaft Type

Control output diagram

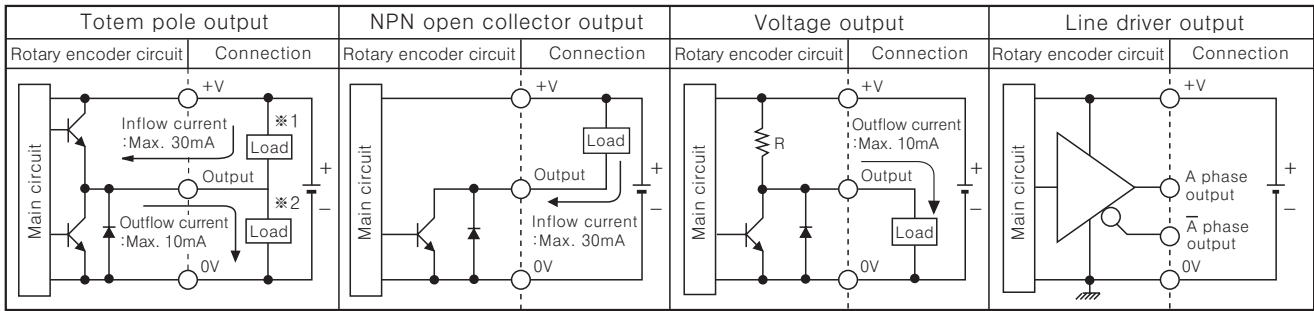

⇒ Totem pole output type can be used for NPN open collector output type(*1) or Voltage output type(*2).
 ⇒ All output circuits of A, B, Z phase is same. (Line driver output is for A, \bar{A} , B, \bar{B} , Z, \bar{Z})

Output waveform

- Totem pole output / NPN open collector output / Voltage output
- Line driver output

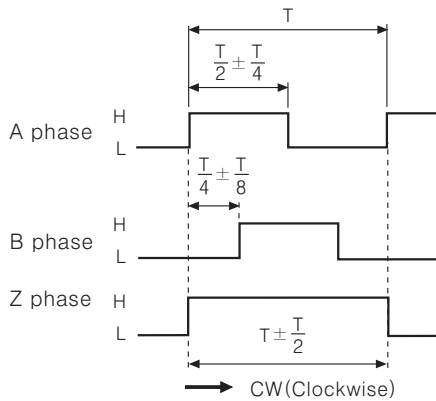

*CW : As viewed from the shaft

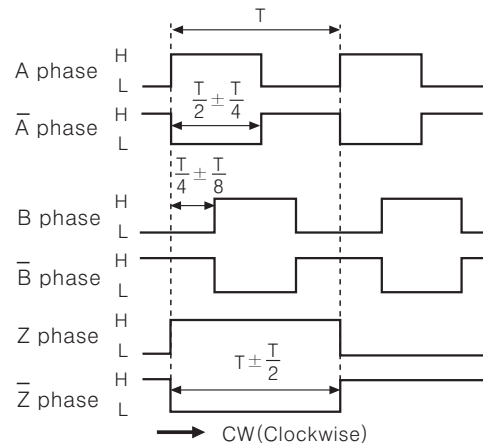

Connections

Normal type

- Totem pole output / NPN open collector output / Voltage output

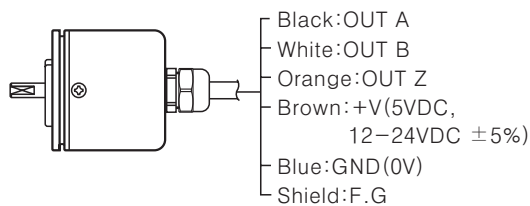

*Unused wires must be insulated.

- Line driver output

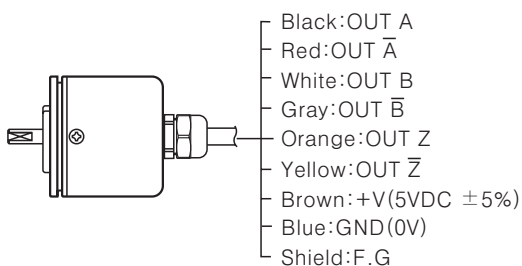

Cable outgoing connector type

- Totem pole output
- Line driver output
- NPN open collector output
- Voltage output



Totem pole output NPN open collector output Voltage output			Line driver output		
Pin No	Function	Cable color	Pin No	Function	Cable color
①	OUT A	Black	①	OUT A	Black
②	OUT B	White	②	OUT \bar{A}	Red
③	OUT Z	Orange	③	+V	Brown
④	+V	Brown	④	GND	Blue
⑤	GND	Blue	⑤	OUT B	White
⑥	F.G	Shield	⑥	OUT \bar{B}	Gray
			⑦	OUT Z	Orange
			⑧	OUT \bar{Z}	Yellow
			⑨	F.G	Shield

*F.G(Field Ground):It should be grounded separately.

- (A) Counter
- (B) Timer
- (C) Temp. controller
- (D) Power controller
- (E) Panel meter
- (F) Tacho/Speed/Pulse meter
- (G) Display unit
- (H) Sensor controller
- (I) Switching power supply
- (J) Proximity sensor
- (K) Photo electric sensor
- (L) Pressure sensor
- (M) Rotary encoder
- (N) Stepping motor & Driver & Controller
- (O) Graphic panel
- (P) Production stoppage models & replacement

E50SP Series

Dimensions

Normal type

(Unit:mm)

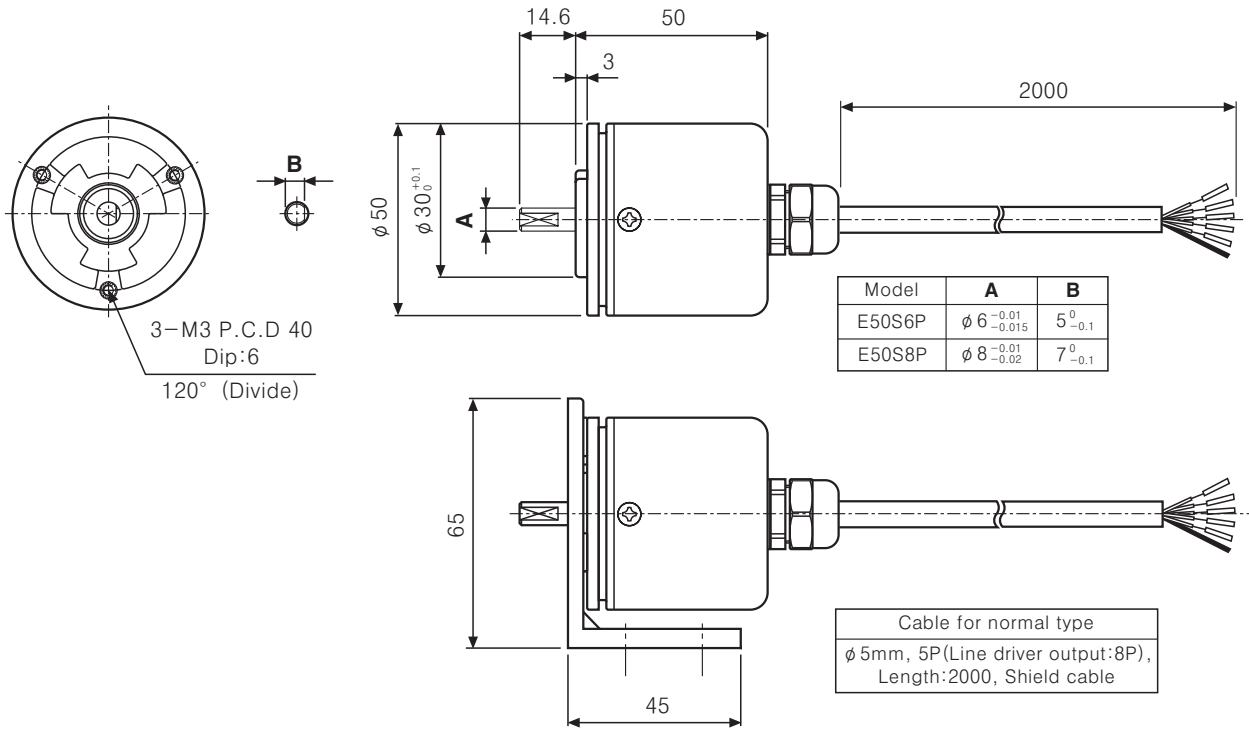

Cable outgoing connector type

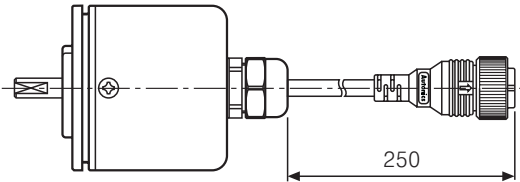

*Connector cable is customizable and see M-46 for specifications.

Bracket

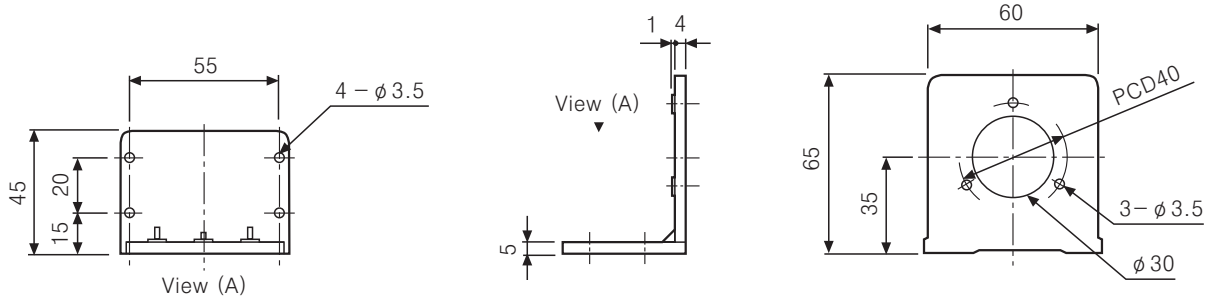

Coupling

• $\phi 6$ coupling

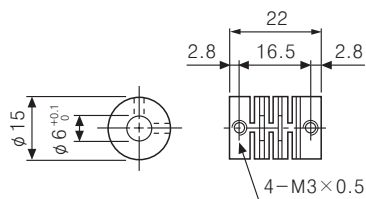

• $\phi 8$ coupling

