



Thank you very much for selecting Autonics products.
For your safety, please read the following before using.

Caution for your safety

- *Please keep these instructions and review them before using this unit.
- *Please observe the cautions that follow:
- Warning** Serious injury may result if instructions are not followed.
- Caution** Product may be damaged, or injury may result if instructions are not followed.
- *The following is an explanation of the symbols used in the operation manual.
- Caution:** Injury or danger may occur under special conditions.

Warning

- In case of using this unit with machinery(Nuclear power control, medical equipment vehicle, train, airplane, combustion apparatus, entertainment or safety device etc), it is required to install fail-safe device.** It may cause a fire, human injury or damage to property.
- Do not disassemble or modify this unit. Please contact us if it is required.** It may give an electric shock and cause a fire.
- Do not disassemble or burn up because lithium battery is used for memory protection.** It may cause an explosion.

Caution

- This unit shall not be used outdoors.** It might shorten the life cycle of the product or give an electric shock.
- Please observe the rated specifications.** It might shorten the life cycle of the product and cause a fire.
- In cleaning the unit, do not use water or an organic solvents.** It might cause a fire.
- Do not use this unit in place where there are flammable or explosive gas, humidity, direct ray of the sun, radiant heat, vibration and impact etc.** It may cause a fire or explosion.
- Do not inflow dust or wire dregs into the unit.** It may cause a fire or malfunction.

Ordering information

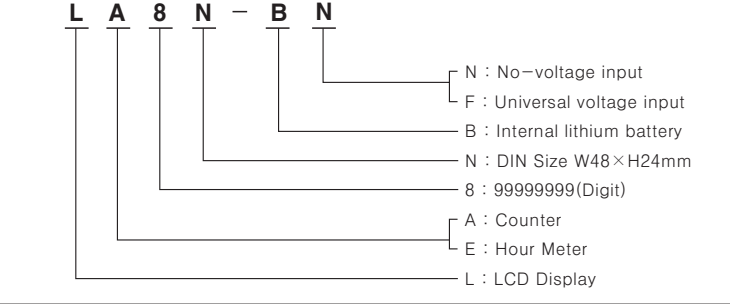

Dimensions

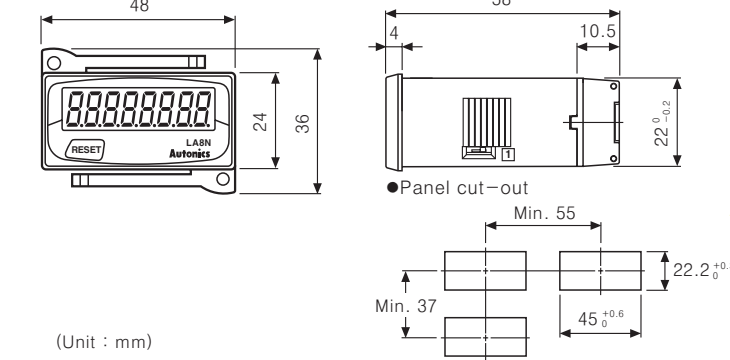

*The above specifications are changeable at anytime without notice.

Specifications

●LA8N Series(COUNTER)

Model	LA8N-BN	LA8N-BF
Input method	No-voltage input	Universal voltage input
Input signal level	Residual voltage:Max. 0.5VDC Short-circuit impedance:Max. 10kΩ Open-circuit impedance:Min. 500kΩ	High : 24~240VAC / 6~240VDC Low : 0~2VAC / 0~2.4VDC
RESET signal	No-voltage input	
Min. Reset signal width	Min. 20ms	
Memory protection	Approx. 7 years at 20°C	
Digit	8 digits	
Operation method	Count up mode	
Counting speed	1cps / 30cps / 1kcps	20cps
Display range	0 ~ 99999999	
External switch	SW1(★1), SW2(★2)	SW1(★1)
	2000VAC 60Hz for 1minute	
Dielectric strength	Between all terminals and case	Between all universal voltage and signal input
		Between all terminals and case
Vibration	Mechanical	0.75mm amplitude at frequency of 10 to 55Hz in each of X, Y, Z directions for 1 hour
	Malfunction	0.3mm amplitude at frequency of 10 to 55Hz in each of X, Y, Z directions for 10 minutes
Shock	Mechanical	300m/s ² (Approx. 30G) 3 times at X, Y, Z direction
	Malfunction	100m/s ² (Approx. 10G) 3 times at X, Y, Z direction
Ambient temperature	-10 to 55°C (at non-freezing status)	
Storage temperature	-25 to 65°C (at non-freezing status)	
Ambient humidity	35 ~ 85%RH	
Power	Built-in lithium battery(Replaceable)	
Display	LCD Zero Blanking method(Character height size:8.7mm)	
Protection	IP66(When using waterproof rubber for front panel), Terminal protection cover(Finger protector)	
Unit weight	Approx. 58g	

*(★1) SW1 is a switch Enable/Disable the front RESET.
 *(★2) SW2 is a switch setting counting speed.

●LE8N Series(HOUR METER)

Model	LE8N-BN	LE8N-BF
Input method	No-voltage input	Universal voltage input
Input signal level	Residual voltage:Max. 0.5VDC Short-circuit impedance:Max. 10kΩ Open-circuit impedance:Min. 500kΩ	High : 24~240VAC / 6~240VDC Low : 0~2VAC / 0~2.4VDC
RESET signal	No-voltage input	
Min. Reset signal width	Min. 20ms	
Memory protection	Approx. 10 years at 20°C	
Digit	8 digits	
Operation method	Count up mode	
Setting time SET1(TS1)	9999.59.59(h.m.s) / 99999.59.9(h.m) / 999999.59(h.m)	
Setting time SET2(TS2)	(★1) 9999H59.9(h.m) / 99999H59(h.m) / 999999H.9(h)	
Time error	Max. ±0.01%	
Temperature error		
External switch	SW1(★2), SW2(★3)	
	2000VAC 60Hz for 1minute	
Dielectric strength	Between all terminals and case	Between all universal voltage and signal input
		Between all terminals and case
Vibration	Mechanical	0.75mm amplitude at frequency of 10 to 55Hz in each of X, Y, Z directions for 1 hour
	Malfunction	0.3mm amplitude at frequency of 10 to 55Hz in each of X, Y, Z directions for 10 minutes
Shock	Mechanical	300m/s ² (Approx. 30G) 3 times at X, Y, Z direction
	Malfunction	100m/s ² (Approx. 10G) 3 times at X, Y, Z direction
Ambient temperature	-10 to 55°C (at non-freezing status)	
Storage temperature	-25 to 65°C (at non-freezing status)	
Ambient humidity	35 ~ 85%RH	
Power	Built-in lithium battery(Replaceable)	
Display	LCD Zero Blanking method(Character height size:8.7mm)	
Protection	IP66(When using waterproof rubber for front panel), Terminal protection cover(Finger protector)	
Unit weight	Approx. 58g	

*(★1) Select TS1, TS2 using inner jump pin(JP1).
 *(★2) SW1 is a switch ENABLE/DISABLE the front RESET.
 *(★3) SW2 is a switch setting time specifications.

Factory specifications

Series Item	LA8N	LE8N
SW1	Disable the front panel RESET key (Terminal block direction)	Disable the front panel RESET key (Terminal block direction)
SW2	Configure 1kcps (Terminal block direction)	999999.59(h.m) (Terminal block direction)
JP1	—	Configure TS1

*SW2 is not available in LA8N-BF. (Fixed as 20cps)

Input connection

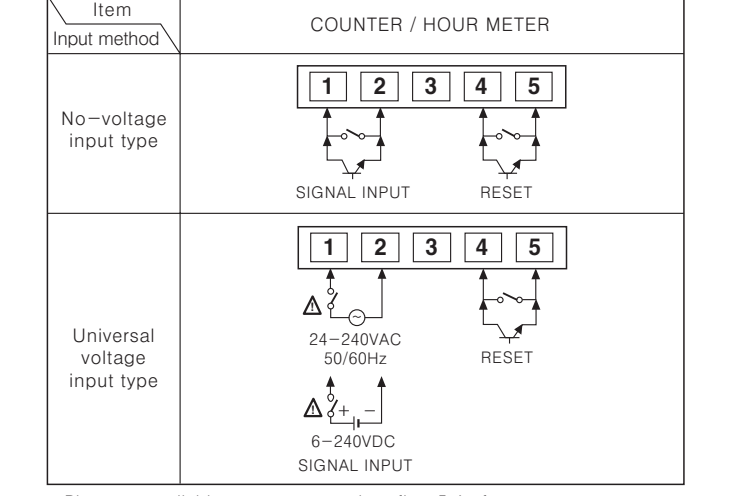

*Please use reliable contacts enough to flow 5mA of current.

Enable/Disable front reset key

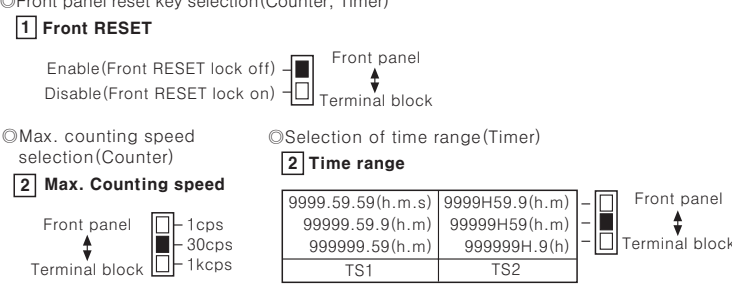

*Please supply RESET signal(Front or external reset terminal) after change time range during the operation.

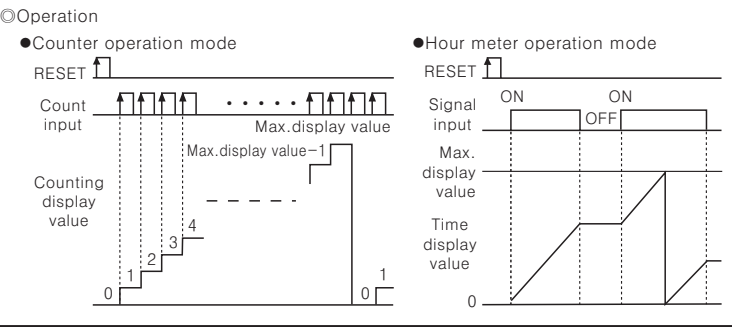

Time specifications(TS1, TS2) and time range

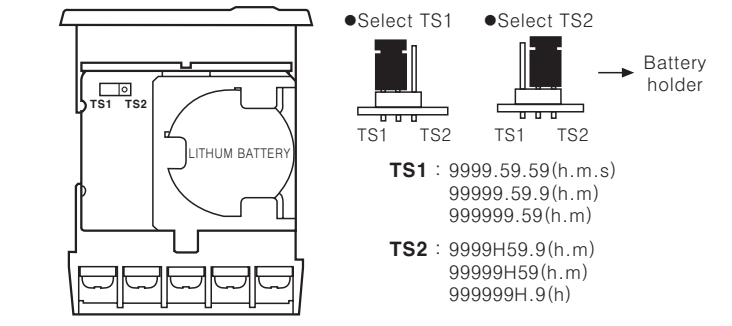

*1 Set of battery is included in the unit.

Case detachment

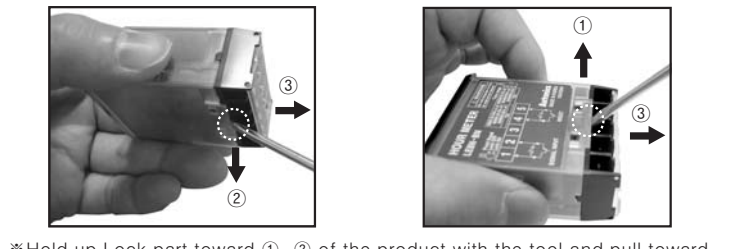

*Hold up Lock part toward ①, ② of the product with the tool and pull toward ③, the case is detached.
 ⚠ Please be careful of the injury caused by tools.

Caution for using

- Do not dispose in a place with danger of flammables or explosion because primary lithium battery is built in the product.
- Change counting speed and time range. Please supply Reset signal(Front or external reset terminal) after change time range during the operation. (Set by display range selection in case of pulse meter.)
- Do not use this unit in the following places
 - A place where ambient temperature is less than -10°C or over 55°C.
 - A place where ambient humidity is less than 35%RH or over 85%RH.
 - A place where there is flammable or corrosive gas, dust, oil, vibration and impact.
 - A place where there are organic solvents including methyl alcohol, benzene, thinner or strong alkalis including ammonia, caustic soda.
 - It shall be used indoor.
- Safe using for battery. This battery has combustibles including lithium organic solvent, it may cause a fire, exothermicity, leakage and explosion, please keep the following.
 - Do not charge, short, disassemble, transform, heating and throw in a fire.
 - Do not put a battery as reverse.
 - Do not use new or used battery and other type of battery together.
 - Do not solder on a battery directly.
 - Insulate a battery to dispose with tape.
 - Do not store where there is direct ray of sun, high temperature and humidity.
- Universal voltage signal input. Do not connect AC type proximity sensor, instead of S/W, as below (Fig.1). It can be operated abnormally because of the leakage current of proximity sensor, please connect relay as (Fig. 2) and use it.

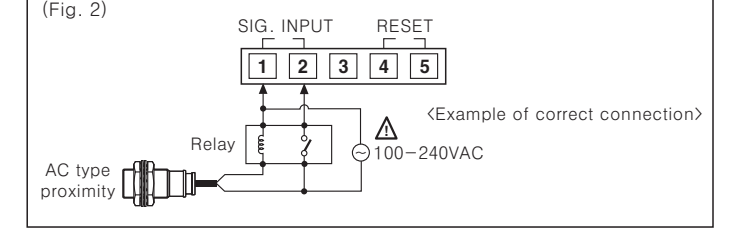
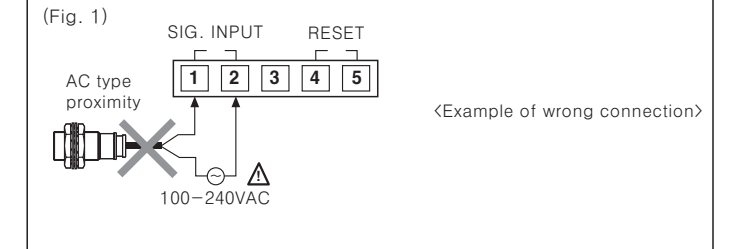

- Installation environment
 - It shall be used indoor
 - Altitude Max. 2000m
 - Pollution Degree 2
 - Installation Category II

*It may cause malfunction if above instructions are not followed.

Major products

- PROXIMITY SENSOR
- PHOTOELECTRIC SENSOR
- AREA SENSOR
- FIBER OPTIC SENSOR
- DOOR/DOOR SIDE SENSOR
- PRESSURE SENSOR
- ROTARY ENCODER
- SENSOR CONTROLLER
- SWITCHING POWER SUPPLY
- TEMPERATURE CONTROLLER
- TEMPERATURE/HUMIDITY TRANSDUCER
- POWER CONTROLLER
- RECORDER
- TACHOMETER/PULSE(RATE) METER
- PANEL METER
- INDICATOR
- SIGNAL CONVERTOR
- COUNTER
- TIMER
- DISPLAY UNIT
- GRAPHIC PANEL
- STEPPING MOTOR & DRIVER
- MOTION CONTROLLER
- LASER MARKING SYSTEM(CO2, Nd:YAG)

Autonics Corporation
 Satisfiable Partner For Factory Automation
 HEAD QUARTERS: 41-5, Yongdang-dong, Yangsan-si, Gyeongsan, 626-847, Korea
 OVERSEAS SALES: Bldg. 402 3rd Fl., Bucheon Techno Park, 193, Yakdae-dong, Wonmi-gu, Bucheon-si, Gyeonggi-do, 420-734, Korea
 TEL: 82-32-610-2730 / FAX: 82-32-329-0728
 E-mail: sales@autonics.com