

BY Series

Small emitter/receiver synchronizing type

■ Features

- Small size : W12×H16×D30mm
- Minimizing malfunction by extraneous light by synchronizing emitter and receiver.
- Reverse power polarity and overcurrent
- Fast response speed : Max. 1ms



⚠ Please read "Caution for your safety" in operation manual before using.

■ Specifications

| Model | Standard type | Side sensing type |
|-----------------------|---|-------------------|
| | BY500-TDT | BYS500-TDT |
| Sensing type | Transmitted beam | |
| Sensing distance | 500mm | |
| Sensing target | Opaque materials of Min. ϕ 5mm | |
| Response time | Max. 1ms | |
| Power supply□ | 12-24VDC \pm 10% (Ripple P-P : Max. 10%) | |
| Current consumption | Max. 30mA | |
| Light source | Infrared LED(modulated) | |
| Operation mode | Dark ON | |
| Control output | NPN open collector output \Rightarrow Load voltage : 30VDC, Load current : Max. 100mA, Residual voltage : Max. 1V | |
| Protection circuit | Reverse polarity protection, Short-circuit protection | |
| Indicator | Operation indicator : Red LED | |
| Connection | Outgoing cable(2m) | |
| Insulation resistance | Min. 20M Ω (at 500VDC mega) | |
| Noise strength | \pm 240V the square wave noise (pulse width:1 μ s) by the noise simulator | |
| Dielectric strength | 1,000VAC 50/60Hz for 1minute | |
| Vibration | 1.5mm amplitude at frequency of 10 ~ 55Hz in each of X, Y, Z directions for 2 hours | |
| Shock | 500m/s ² (50G) in X, Y, Z directions for 3 times | |
| Ambient illumination | Sunlight : Max. 11,000 lx, Incandescent lamp : Max. 3,000 lx | |
| Ambient temperature | -10 ~ +60°C (at non-freezing status), Storage : -25 ~ +70°C | |
| Ambient humidity | 35 ~ 85%RH, Storage : 35 ~ 85%RH | |
| Protection | IP50(IEC standard) | |
| Material□ | Case : ABS, Lens : Acrylic□ | |
| Cable | 4P, ϕ 4mm, Length : 2m | |
| Accessory | Fixing bracket, Bolts/Nuts | |
| Unit weight | Approx. 150g | |

Small and Amplifier Built-in Type

Feature data

●BY500-TDT ●BYS500-TDT

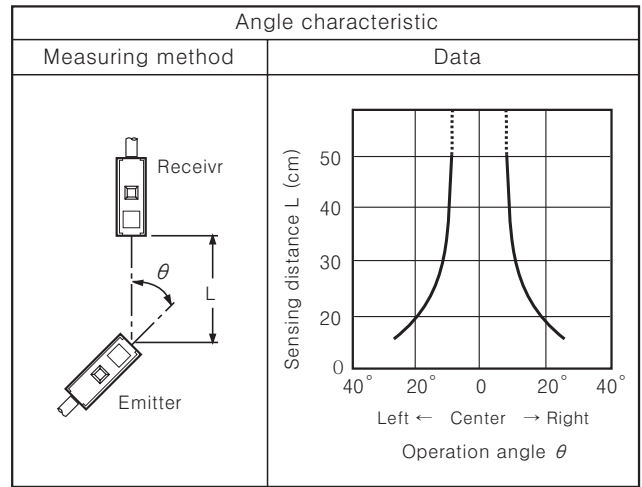
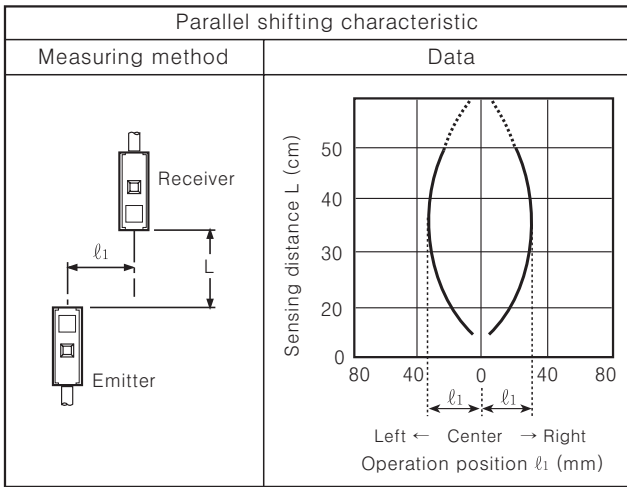

Control output diagram

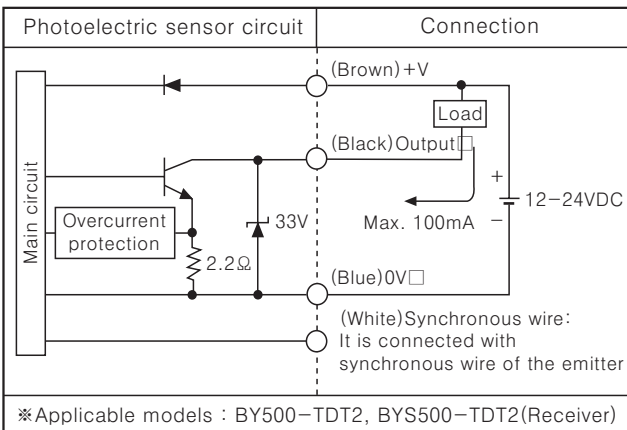

- ※ If the control output terminal is short-circuited or overcurrent condition is existed, the control output will turn off due to protection circuit.
- ※ Please supply the power to Brown and Blue wire of emitter and Synchronous wire(White) of the receiver must be connected with that of the emitter.

Operation mode

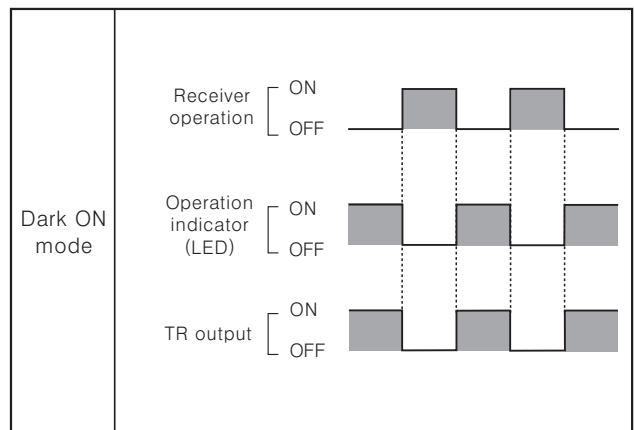

Connections

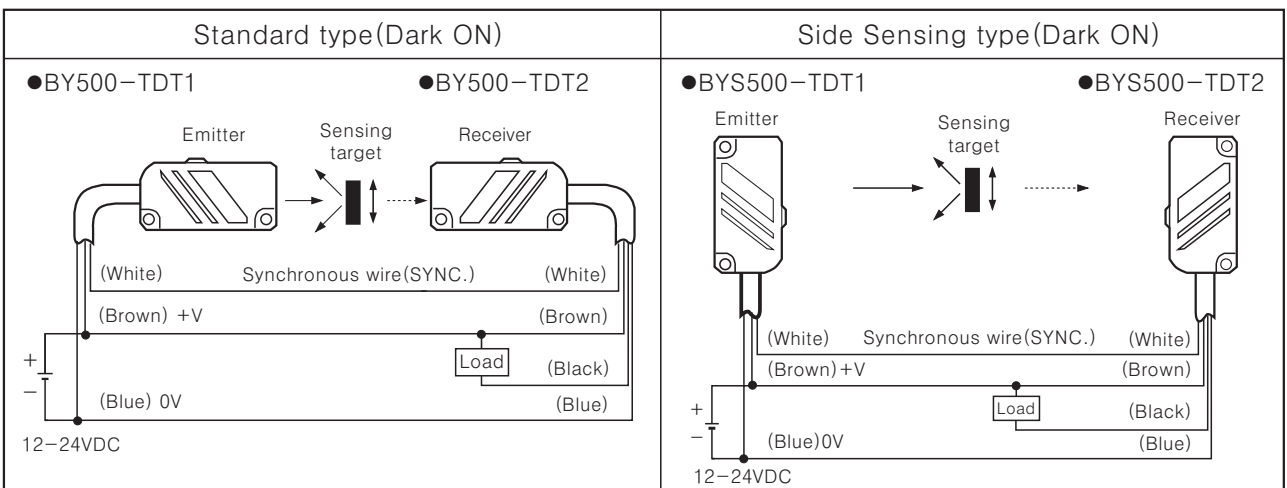

- ※ The power of the emitter and the receiver must be supplied from same power line.
- ※ Synchronous wire(White) of the receiver must be connected with that of the emitter.

(A) Counter

(B) Timer

(C) Temp. controller

(D) Power controller

(E) Panel meter

(F) Tacho/Speed/Pulse meter

(G) Display unit

(H) Sensor controller

(I) Switching power supply

(J) Proximity sensor

(K) Photo electric sensor

(L) Pressure sensor

(M) Rotary encoder

(N) Stepping motor & Driver & Controller

(O) Graphic panel

(P) Production stoppage models & replacement

BY Series

■ Dimensions

(Unit:mm)

●Product(BY500-TDT)

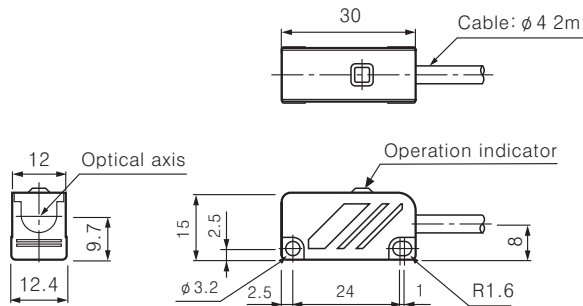

●Product(BYS500-TDT)

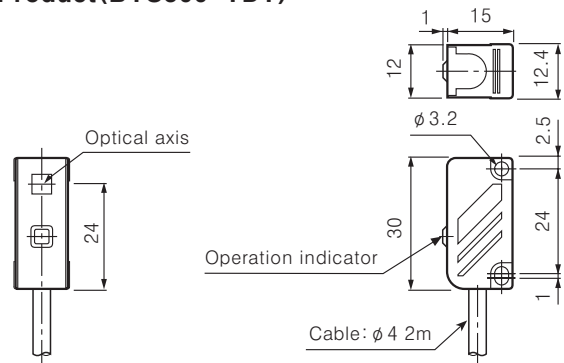

●Bracket(BY500-TDT)

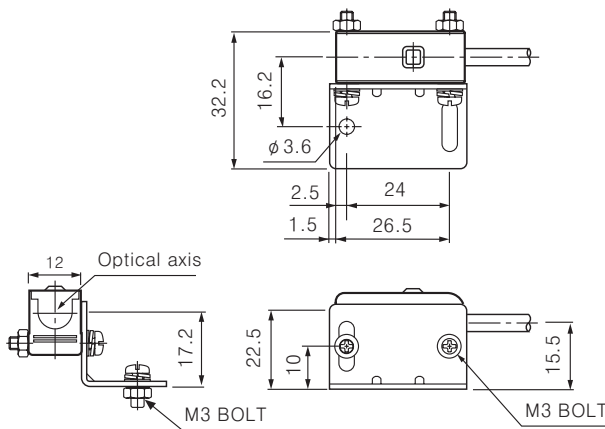

●Bracket(BYS500-TDT)

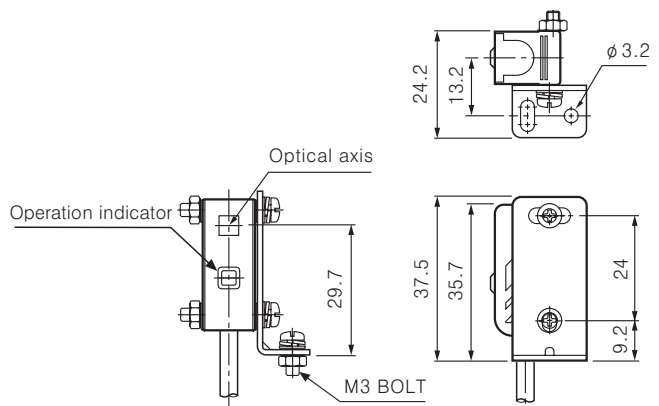

●Bracket(BY500-TDT)

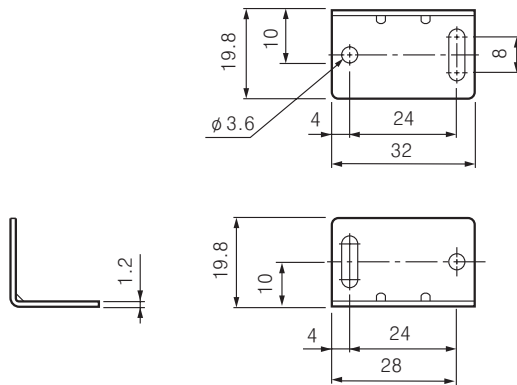

●Bracket(BYS500-TDT)

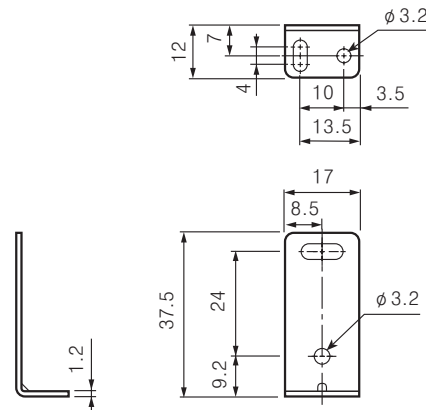

■ Mounting and sensitivity adjustment

1. Supply the power to the sensor, after install the emitter and the receiver facing each other.
 2. Set the receiver in the middle of position where indicator turns on adjusting the receiver to the right and the left or up and down.
 3. Fix both units tightly after checking that the unit detect the target.
- ※If the sensing target is translucent body or smaller than $\phi 5\text{mm}$, it might not be detected because the target allows too much light to pass.

