

**Autonics**

**ROTARY ENCODER(INCREMENTAL TYPE)  
ENA/E50S8/ENC SERIES**

**M A N U A L**



Thank you very much for selecting Autonics products.  
For your safety, please read the following before using.

**Caution for your safety**

- Please keep these instructions and review them before using this unit.
- Please observe the cautions that follow:
- Warning** Serious injury may result if instructions are not followed.
- Caution** Product may be damaged, or injury may result if instructions are not followed.
- The following is an explanation of the symbols used in the operation manual.
- caution: Injury or danger may occur under special conditions.
- Warning**
- 1. When use this unit for controlling highly affective equipment to human or properties. (Medical instrument, Vehicles, Train, Airplane, combustion apparatus, entertainment etc.), it requires installing a fail safety device.** It may cause serious human injury or a fire, property.

**Caution**

- Do not drop water or oil on this unit.** It may cause damage or malfunction due to malfunction.
- Please observe voltage rating.** It may shorten the life cycle or damage to the product.
- Please check the polarity of power and wrong wiring.** It may result in damage to this unit.
- Do not short circuit the load.** It may result in damage to this unit.

**Outline**

This unit is very useful to control length, angle and position by converting revolution value of shaft into number of pulse as an optical incremental Encoder.

**Ordering information**

ENA	5000	2	N	24		
Series	Pulse/1 Revolution	Output phase	Output	Power supply		
Shaft type to be mounted at the side	See resolution	2:A, B 3:A, B, Z	T: Totem pole output N: NPN open collector output V: Voltage output	5 :5VDC ±5% 24:12~24VDC ±5%		
*Standard: ENA-PULSE-2-N-24 *Standard: A, B						
E50S	8	3	N	24		
Series	Shaft diameter	Pulse/1 Revolution	Output phase	Output	Power supply	Cable
Diameter ø50mm, shaft type	ø8mm	See resolution	2:A, B 3:A, B, Z (Standard) 4:A, A, B, B 6:A, A, B, B, Z, Z	T: Totem pole output N: NPN open collector output V: Voltage output L: Line driver output	5 :5VDC ±5% 24:12~24VDC ±5%	No mark: Normal type *C: Cable outgoing connector type
*Standard: E50S8-PULSE-3-N-24 *The power of Line driver is only for 5VDC					*Cable length : 250mm	
ENC	1	1	N	24		
Series	Output phase	Min. measuring unit	Output	Power supply	Cable	
Wheel type	1:A, B phase	1:1mm 3:1m 5:0.1yd 2:1cm 4:0.01yd 6:1yd	T: Totem pole output N: NPN open collector output V: Voltage output	5:5VDC ±5% 24:12~24VDC ±5%	No mark: Normal type *C: Cable outgoing connector type	
*Cable length: 250mm						

**Control output diagram**

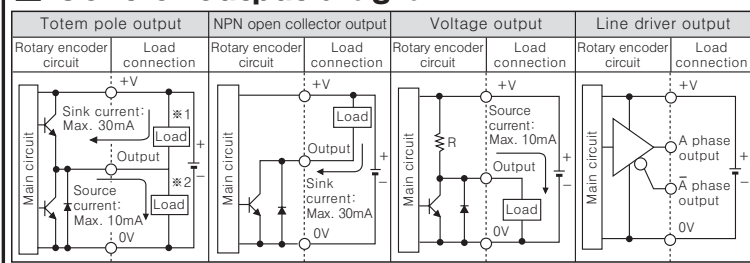

The output circuit of A, B, Z phase are the same. (Line Driver output is A, A, B, B, Z, Z)  
Totem pole output can be used for NPN open collector type(\*1) or voltage output type(\*2).  
**The above specification are changeable without notice anytime.**

**Specifications**

Item	Shaft type the encoder to be mounted at the side(Incremental)	ø50mm Shaft type Incremental Rotary encoder	Wheel type the Incremental type Rotary encoder	
Model	Totem pole output	ENA-□-3-T-□	E50S8-□-3-T-□	ENC-1-□-T-□
	NPN open collector output	ENA-□-3-N-□	E50S8-□-3-N-□	ENC-1-□-N-□
	Voltage output	ENA-□-3-V-□	E50S8-□-3-V-□	ENC-1-□-V-□
	Line driver output	ENA-□-6-L-□	E50S8-□-6-L-□	
Resolution(P/R)	(Note1) +1, +2, +5, 10, +12, 15, 20, 23, 25, 30, 35, 40, 45, 50, 60, 75, 100, 120, 125, 150, 192, 200, 240, 250, 256, 300, 360, 400, 500, 512, 600, 800, 1000, 1024, 1200, 1500, 1800, 2000, 2048, 2500, 3000, 3600, 5000, 6000, 8000	A, B, Z phase (Line driver output : A, A, B, B, Z, Z phase)	1mm/Pulse, 1cm/Pulse, 1m/Pulse, 0.01yd/Pulse, 0.1yd/Pulse, 1yd/Pulse	
Electrical specification	Output phase	A phase, B phase(Option : A, B, Z phase)	A phase, B phase	
	Phase difference of output	Output between A and B phase : $\frac{T}{4} \pm \frac{T}{8}$ (T=1 cycle of A phase)		
	Totem pole output	• Low Load current : Max. 30mA, Residual voltage : Max. 0.4VDC • High Load current : Max. 10mA, Output voltage(Power voltage 5VDC) : Min. (Power voltage-2.0)VDC, Output voltage(Power voltage 12~24VDC) : Min. (Power voltage-3.0)VDC		
	NPN open collector output	Load current : Max. 30mA, Residual voltage : Max. 0.4VDC		
Control output	Voltage output	Load current : Max. 10mA, Residual voltage : Max. 0.4VDC		
	Line driver output	• Low Load current : Max. 20mA, Residual voltage : Max. 0.5VDC • High Load current : Max. -20mA, Output voltage : Min. 2.5VDC		
Response time (Rise/Fall)	Totem pole output	Max. 1µs (Cable length:2m, I sink=Max. 20mA)		
	NPN open collector output			
	Voltage output			
	Line driver output	Max. 0.5µs (Cable length:2m, I sink=Max. 20mA)		
Max. Response frequency	300kHz		180kHz	
Power supply	• 5VDC ±5% (Ripple P-P:Max. 5%)		• 12~24VDC ±5% (Ripple P-P:Max. 5%)	
Current consumption	Max. 60mA(disconnection of the load), Line driver output : Max. 50mA(disconnection of the load)			
Insulation resistance	Min. 100MΩ(at 500VDC between all terminals and case)			
Dielectric strength	750VAC 50/60Hz for 1 minute(Between all terminals and case)			
Connection	Connector connection	Cable outgoing type, 250mm Cable outgoing connector type		
Mechanical specification	Starting torque	Max. 70gf • cm(0.007N • m)		
	Moment of inertia	Max. 80g • cm <sup>2</sup> (8 × 10 <sup>-6</sup> kg • m <sup>2</sup> )		
	Shaft loading	Radial : 10kgf, Thrust : 2.5kgf		
	Max. allowable revolution	(Note2) 5000rpm		
Vibration	1.5mm amplitude at frequency of 10 ~ 55Hz in each of X, Y, Z directions for 2 hours			
Shock	Max. 75G			
Ambient temperature	-10 ~ 70°C (at non-freezing status), Storage : -25 ~ 85°C			
Ambient humidity	35 ~ 85%RH, Storage : 35~90%RH			
Protection	IP50(IEC standard)			
Cable	ø5mm, 5P, Length:2m, Shield cable	ø5mm, 5P, Length:2m, Shield cable (Line driver output: ø5mm, 8P)	ø5mm, 5P, Length:2m, Shield cable	
Accessory	ø10mm coupling	ø8mm coupling, Bracket		
Weight	Approx. 345g	Approx. 275g	Approx. 494g	
Approval	CE (Except Line driver output)			

(Note1) 1, 2, 5 12 P/R are output A and B phase only. (But Line driver output : A, A, B, B phase)  
(Note2) Max. allowable revolution ≥ Max. response revolution [Max. response revolution(rpm) =  $\frac{\text{Max. response frequency}}{\text{Resolution}} \times 60 \text{ sec}$ ]  
Please select the resolution to make lower max. revolution than max. allowable revolution.

**Dimensions**

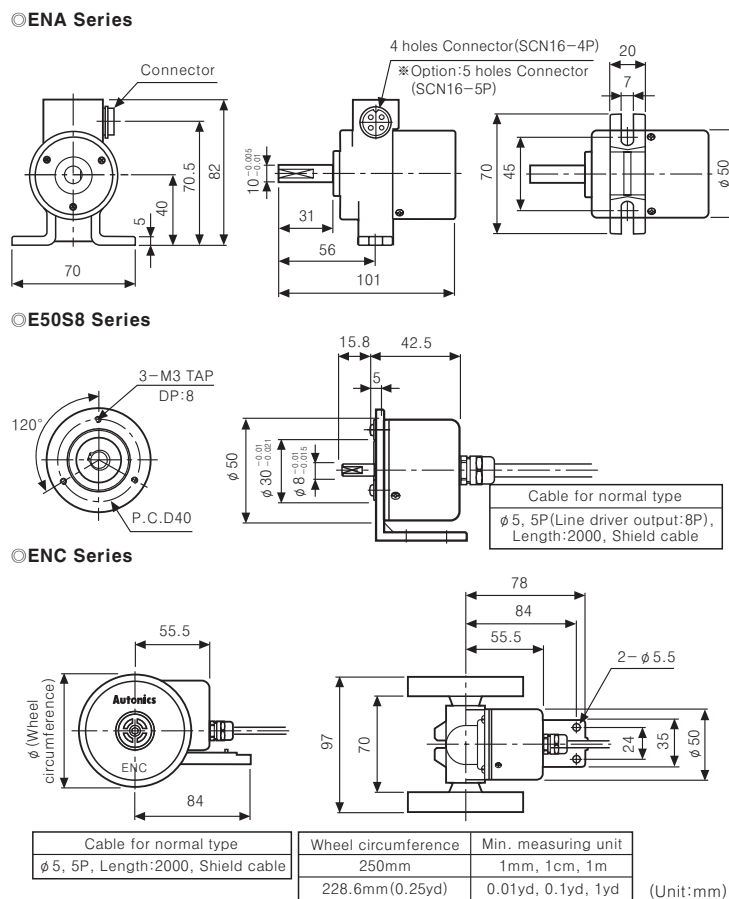

**Connections**

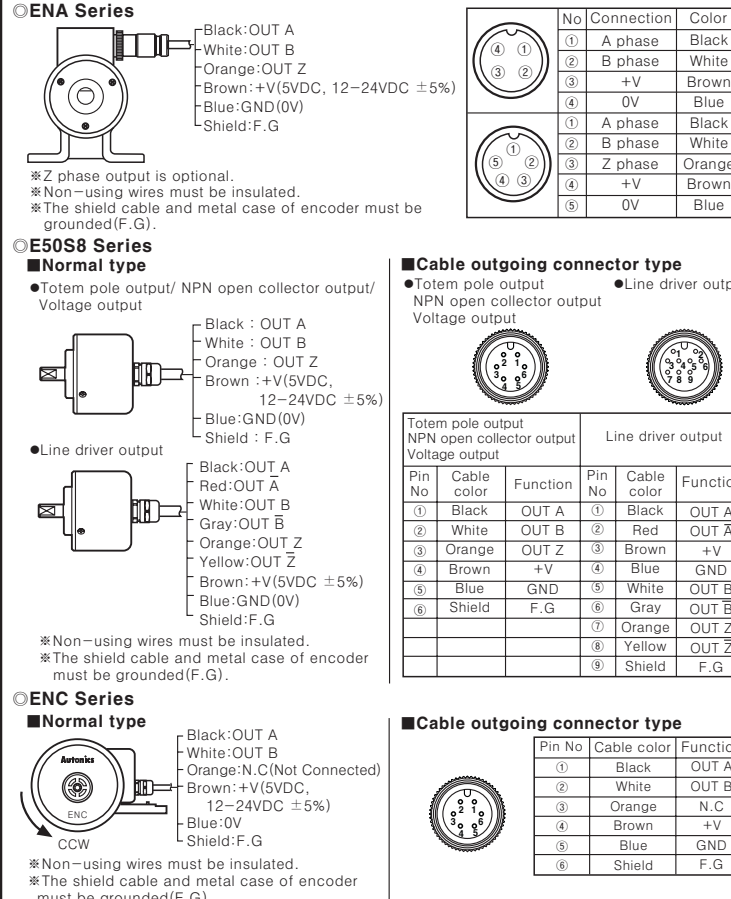

**Accessory**

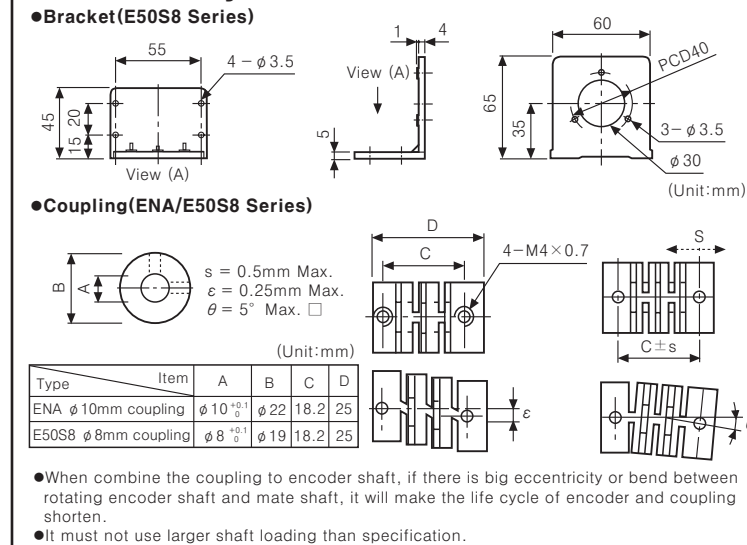

**Output waveform**

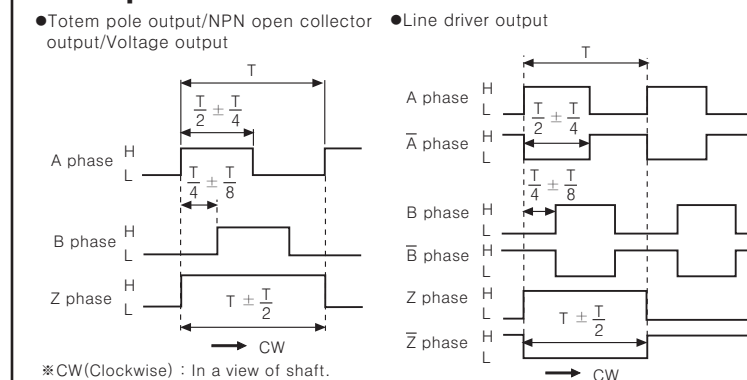

**Caution for using**

- Installation
  - This unit is consisted of precision components. Therefore please treat this product carefully.
  - When you install this unit, if eccentricity and deflection angle are larger, it may shorten the life cycle of this unit. (ENA, E50S8)
  - Please mount this unit on panel with lowest the coefficient of friction between rotating detection part and target. It may shorten the life cycle of this unit. (ENC)
  - Do not put strong impact when insert coupling into shaft. (ENA, E50S8)
- For using
  - Please use attached SIL Twist pair wire and use proper receiver for RS-422A communication.
  - Do not connect and cut circuit off during power on. It may result in damage to this unit.
  - When the power source is a Switching power, please install the surge absorber in power line and wire should be shorter in order not to be influenced by noise.
- Environment
  - Please do not use this unit with below environment, it results in malfunction.
    - Place where this unit or component may be damaged by strong vibration or impact.
    - Place where there are lots of flammable or corrosive gases.
    - Place where strong magnet field or electric noise are occurred.
    - Place where is beyond of rating temperature or humidity.
    - Place where strong acids or alkali near by.
- Vibration and Impact
  - When the strong impact loads on this unit, the error pulse may occur as if the slit is revolving.
  - Encoder with high resolution can be easily affected by vibration, therefore fix the sub mounting metallic ball when install this unit.
- Wire connection
  - Do not draw the wire with over 30N strength after wiring.
  - When a high voltage or power line pass near by the encoder cable, be sure to wire the encoder cable in separated conduit to prevent malfunction.

**It may cause malfunction if above instructions are not followed.**

**Major products**

- PROXIMITY SENSOR
- PHOTOELECTRIC SENSOR
- AREA SENSOR
- FIBER OPTIC SENSOR
- DOOR/DOOR SIDE SENSOR
- PRESSURE SENSOR
- ROTARY ENCODER
- COUNTER
- TIMER
- TEMPERATURE CONTROLLER
- TEMPERATURE/HUMIDITY TRANSDUCER
- POWER CONTROLLER
- PANEL METER
- TACHO/LINE SPEED/PULSE METER
- DISPLAY UNIT
- SENSOR CONTROLLER
- SWITCHING POWER SUPPLY
- GRAPHIC PANEL
- 5-PHASE STEPPING MOTOR & DRIVER & CONTROLLER
- LASER MARKING SYSTEM(CO<sub>2</sub>, Nd:YAG)

**Autonics Corporation**  
http://www.autonics.com  
Global Partner for IA

**HEADQUARTERS :**  
41-5, Yongdang-ri, Ulsangang-eup, Yangsan-si, Gyeongsang, 626-847, Korea

**OVERSEAS SALES :**  
Bldg. 402 3rd Fl., Bucheon Techno Park, 193, Yakdae-dong, Wonmi-gu, Bucheon-si, Gyeonggi-do, 420-734, Korea  
TEL:82-32-610-2730 / FAX:82-32-329-0728  
E-mail : sales@autonics.com