

# Autonics ROTARY ENCODER(INCREMENTAL TYPE) E50S SERIES

M A N U A L



Thank you very much for selecting Autonics products.  
For your safety, please read the following before using.

## Caution for your safety

- Please keep these instructions and review them before using this unit.
- Please observe the cautions that follow:
- Warning** Serious injury may result if instructions are not followed.
- Caution** Product may be damaged, or injury may result if instructions are not followed.
- The following is an explanation of the symbols used in the operation manual.
- caution: Injury or danger may occur under special conditions.

## Warning

1. When use this unit for controlling highly affective machinery to human or properties (medical equipment, vehicle, train, airplane, combustion apparatus and entertainment etc.), it is required to install fail-safe device. It may cause serious human injury or a fire, property.

## Caution

- Do not drop water or oil on this unit. It may cause damage or malfunction due to malfunction.
- Please observe voltage rating. It may shorten the life cycle or damage to the product.
- Please check the polarity of power and wrong wiring. It may result in damage to this unit.
- Do not short circuit the load. It may result in damage to this unit.

## Outline

It is widely used in length, angle and position control by converting revolution value of shaft into number of pulse as an optical incremental Encoder.

## Ordering information

Series	Shaft diameter	Pulse/1 Revolution	Output phase	Output	Power supply	Cable
E50S 8 8000 3 N 24	ø8mm	See resolution	2:A, B 3:A, B, Z (Standard) 4:A, $\bar{A}$ , B, $\bar{B}$ 6:A, $\bar{A}$ , B, $\bar{B}$ , Z, $\bar{Z}$	T: Totem pole output N: NPN open collector output V: Voltage output L: Line driver output	5: 5VDC ± 5% 24: 12~24VDC ± 5%	No mark: Normal type C: Cable outgoing connector type (250mm) CR: Rear connector integrated type CS: Side connector integrated type

\*Standard: E50S8-□□□□-3-N-24 \*The power of Line driver is only for 5VDC

Series	Shaft diameter	External material	Pulse/1 Revolution	Output phase	Output	Power supply	Cable
E50S 6 P 600 3 N 24	ø6mm	P: Plastic	See resolution	2:A, B 3:A, B, Z (Standard) 4:A, $\bar{A}$ , B, $\bar{B}$ 6:A, $\bar{A}$ , B, $\bar{B}$ , Z, $\bar{Z}$	T: Totem pole output N: NPN open collector output V: Voltage output L: Line driver output	5: 5VDC ± 5% 24: 12~24VDC ± 5%	No mark: Normal type C: Cable outgoing connector type (250mm)

\*Standard: E50S6P-□□□□-3-N-24 \*The power of Line driver is only for 5VDC

## Control output diagram

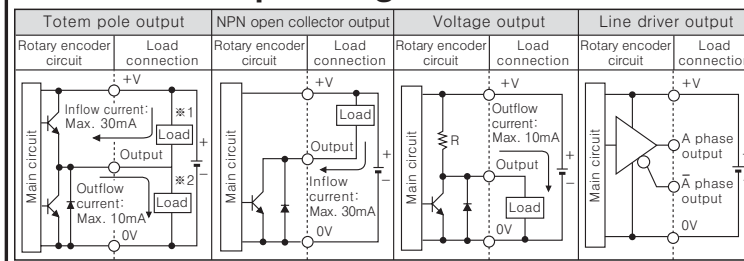

The output circuit of A, B, Z phase are the same. (Line Driver output is A,  $\bar{A}$ , B,  $\bar{B}$ , Z,  $\bar{Z}$ )  
Totem pole output can be used for NPN open collector type(\*1) or voltage output type(\*2).  
The above specifications are changeable at anytime without notice.

## Specifications

Item	ø50mm Shaft type Incremental Rotary encoder		
Model	Totem pole output	E50S8-□□□□-3-T-□	E50SP-□□□□-3-T-□
	NPN open collector output	E50S8-□□□□-3-N-□	E50SP-□□□□-3-N-□
	Voltage output	E50S8-□□□□-3-V-□	E50SP-□□□□-3-V-□
	Line driver output	E50S8-□□□□-6-L-5	E50SP-□□□□-6-L-5
Resolution (P/R)	(Note1) *1, *2, *5, 10, *12, 15, 20, 23, 25, 30, 35, 40, 45, 50, 60, 75, 100, 120, 125, 150, 192, 200, 240, 250, 256, 300, 360, 400, 500, 512, 600, 800, 1000, 1024, 1200, 1500, 1800, 2000, 2048, 2500, 3000, 3600, 5000, 6000, 8000	*1, *2, *5, 10, *12, 15, 20, 23, 25, 30, 35, 40, 45, 50, 60, 75, 100, 120, 125, 150, 192, 200, 240, 250, 256, 300, 360, 400, 500, 512, 600	
Output phase	A, B, Z phase (Line driver output: A, $\bar{A}$ , B, $\bar{B}$ , Z, $\bar{Z}$ phase)		
Phase difference of output	Output between A and B phase: $\frac{T}{4} \pm \frac{T}{8}$ (T=1 cycle of A phase)		
Electrical specification	Totem pole output	• Low Load current: Max. 30mA, Residual voltage: Max. 0.4VDC • High Load current: Max. 10mA, Output voltage (Power voltage 5VDC): Min. (Power voltage-2.0)VDC, Output voltage (Power voltage 12~24VDC): Min. (Power voltage-3.0)VDC	
	NPN open collector output	Load current: Max. 30mA, Residual voltage: Max. 0.4VDC	
	Voltage output	Load current: Max. 10mA, Residual voltage: Max. 0.4VDC	
	Line driver output	• Low Load current: Max. 20mA, Residual voltage: Max. 0.5VDC • High Load current: Max. 20mA, Output voltage: Min. 2.5VDC	
Res-ponse time (Rise/Fall)	Max. 1µs (Cable length: 2m, I sink=20mA)		
Max. Response frequency	300kHz	180kHz	
Power supply	5VDC ± 5% (Ripple P-P: Max. 5%) / 12~24VDC ± 5% (Ripple P-P: Max. 5%)		
Current consumption	Max. 80mA (disconnection of the load), Line driver output: Max. 50mA (disconnection of the load)		
Insulation resistance	Min. 100MΩ (at 500VDC between all terminals and case)		
Dielectric strength	750VAC 50/60Hz for 1 minute (Between all terminals and case)		
Connection	Cable outgoing type, Cable outgoing connector type, Connector integrated type (rear, side) / Cable outgoing type, Cable outgoing connector type		
Mechanical specification	Starting torque	Less than 70gf·cm (0.007N·m), Connector integrated type: Less than 800gf·cm (0.08N·m) / Max. 100gf·cm (0.01N·m)	
	Moment of inertia	Less than 80g·cm <sup>2</sup> (8×10 <sup>-6</sup> kg·m <sup>2</sup> ), Connector integrated type: Less than 400g·cm <sup>2</sup> (4×10 <sup>-6</sup> kg·m <sup>2</sup> ) / Max. 40g·cm <sup>2</sup> (4×10 <sup>-6</sup> kg·m <sup>2</sup> )	
	Shaft loading	Radial: Max. 10kg·f, Thrust: Max. 2.5kg·f / Radial: Max. 2kg·f, Thrust: Max. 1kg·f	
	Max. allowable revolution	(Note2) 5000rpm	
Vibration	1.5mm amplitude at frequency of 10 ~ 55Hz in each of X, Y, Z directions for 2 hours		
Shock	Max. 75G		
Ambient temperature	-10 ~ 70°C (at non-freezing status), Storage: -25 ~ 85°C		
Ambient humidity	35 ~ 85%RH, Storage: 35~90%RH		
Protection	(Note3) IP50 (IEC standard), Connector integrated type: IP65 (IEC standard) / IP50 (IEC standard)		
Cable	ø5mm, 5P, Length: 2m, Shield cable (Line driver output: ø5mm, 8P)		
Accessory	ø8 (ø6)mm coupling, Bracket		
Unit weight	Approx. 275g, Connector integrated type: Approx. 180g	Approx. 235g	
Approval	Normal type CE (Except Line driver output)		

(Note1) 1, 2, 5, 12 P/R are output A and B phase only. (But Line driver output: A,  $\bar{A}$ , B,  $\bar{B}$  phase) It is limited to customize under 1000P/R for connector integration type.  
(Note2) Max. allowable revolution ≥ Max. response revolution [Max. response revolution (rpm) =  $\frac{\text{Max. response frequency}}{\text{Resolution}} \times 60 \text{ sec}$ ]  
Please select the resolution to make lower max. revolution than max. allowable revolution.  
(Note3) It is customizable into IP64 rated.

## Dimensions

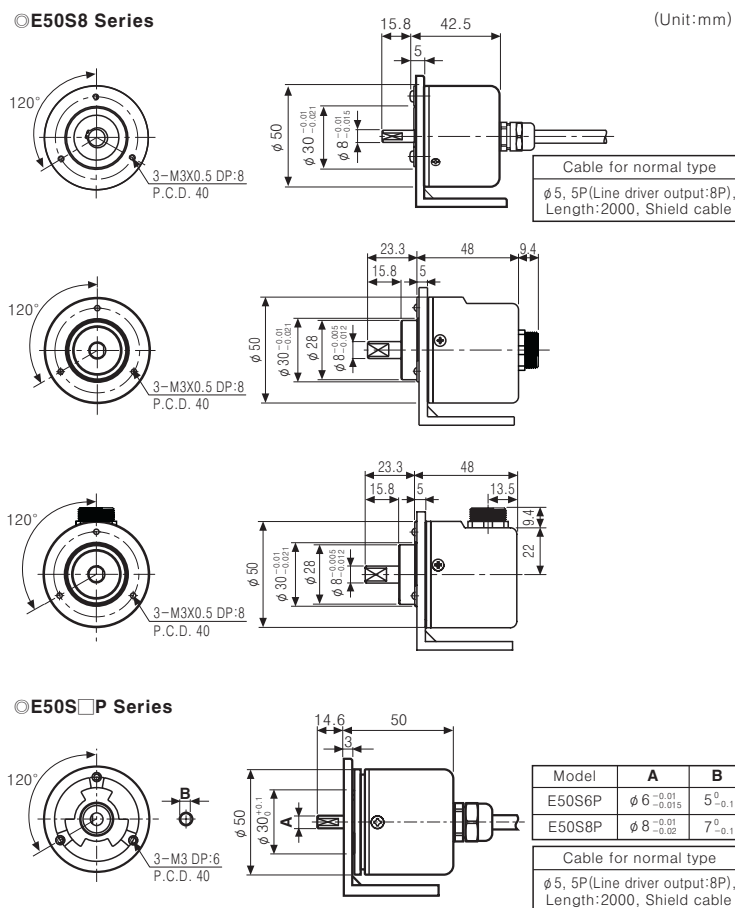

## Connections

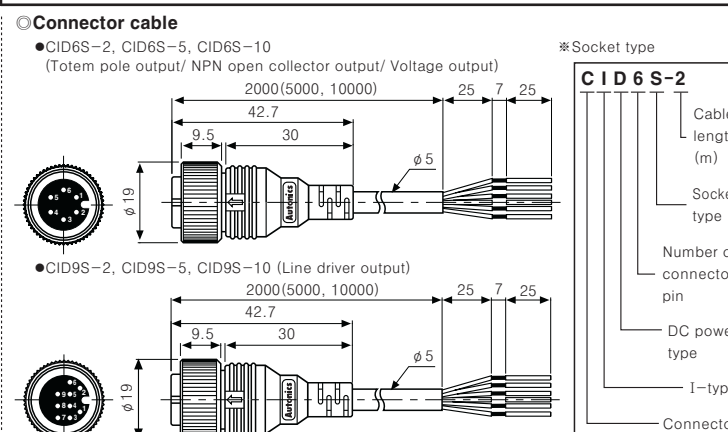
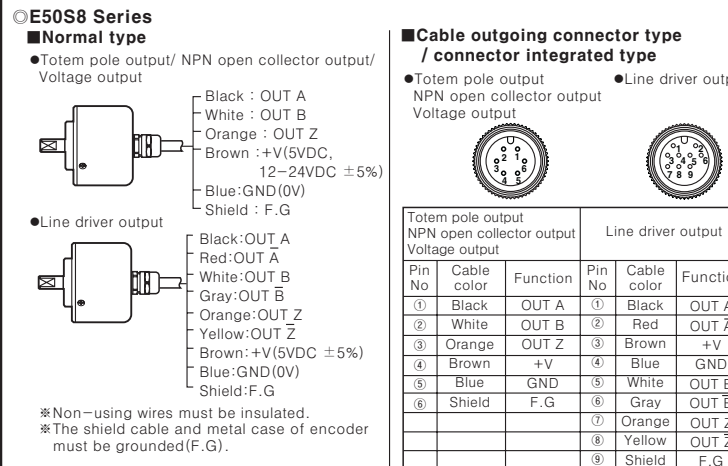

## Accessory

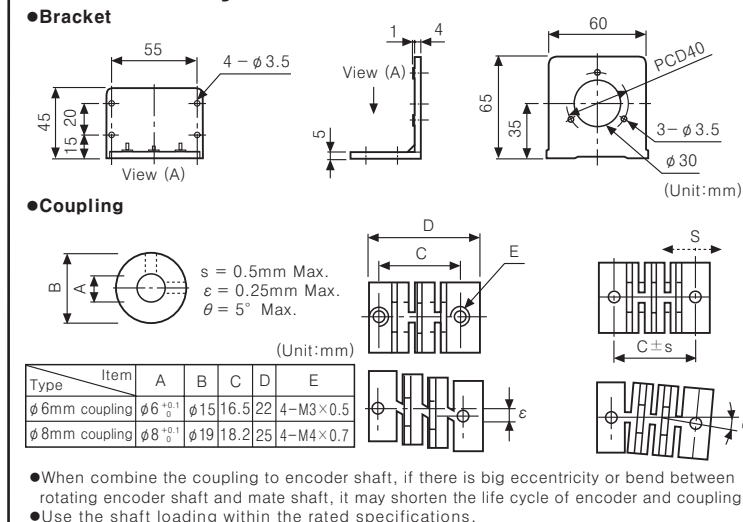

## Output waveform

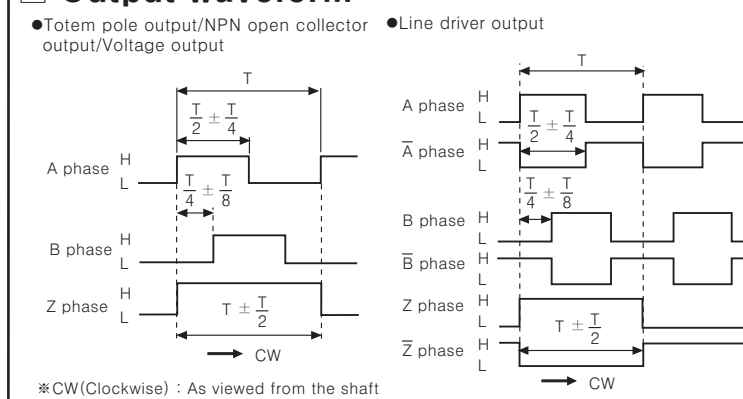

## Caution for using

- Installation
    - Handle the unit with care, it is consisted of precision components.
    - Be careful not to make eccentricity and deflection angle larger, it may shorten the life cycle.
    - Do not put strong impact when insert coupling into shaft.
  - For using
    - Please use attached SIL Twist pair wire and use proper receiver for RS-422A communication.
    - Do not connect and cut circuit during power on, or it may cause damage to the unit.
    - When use switching power, install the surge absorber in power line and shorter the wire to avoid noise.
  - Environment
    - Please do not use this unit with below environment, it results in malfunction.
      - Place where this unit or component may be damaged by strong vibration or impact.
      - Place where there are lots of flammable or corrosive gases.
      - Place where strong magnet field or electric noise are occurred.
      - Place where is beyond of rating temperature or humidity.
      - Place where strong acids or alkali near by.
    - Vibration and Impact
      - When the strong impact loads on this unit, it may cause an error.
      - High resolution of encoder can be easily affected by vibration, fix the bracket firmly to install.
    - Wire connection
      - Do not draw the wire with over strength 30N after wiring.
      - If wire encoder cable with high voltage line or power cable in the same conduit, it may cause a malfunction or mechanical problem. Please wire it separately or use separated conduit.
- \*It may cause malfunction if above instructions are not followed.

## Major products

**■ PROXIMITY SENSOR ■ PHOTOELECTRIC SENSOR ■ AREA SENSOR**  
**■ FIBER OPTIC SENSOR ■ DOOR/DOOR SIDE SENSOR**  
**■ PRESSURE SENSOR ■ ROTARY ENCODER**  
**■ SENSOR CONTROLLER**  
**■ SWITCHING POWER SUPPLY**  
**■ TEMPERATURE CONTROLLER**  
**■ TEMPERATURE/HUMIDITY TRANSDUCER**  
**■ POWER CONTROLLER ■ RECORDER**  
**■ TACHOMETER/PULSE(RATE) METER**  
**■ PANEL METER ■ INDICATOR**  
**■ SIGNAL CONVERTOR ■ COUNTER**  
**■ TIMER ■ DISPLAY UNIT**  
**■ GRAPHIC PANEL**  
**■ STEPPING MOTOR & DRIVER**  
**& MOTION CONTROLLER**

**Autonics Corporation**  
<http://www.autonics.com>

**Satisfiable Partner For Factory Automation**

**HEAD QUARTERS**  
 41-5, Yongdang-dong, Yangsan-si, Gyeongsang, 626-847, Korea

**ROVERSEAS SALES:**  
 Bldg. 402 3rd Fl., Bucheon Techno Park, 193, Yakdae-dong, Wonmi-gu, Bucheon-si, Gyeonggi-do, 420-734, Korea  
 TEL: 82-32-610-2730 / FAX: 82-32-329-0728  
 E-MAIL: sales@autonics.com

The proposal of a product improvement and development: Product@autonics.com  
 EP-KE-09-0140