

Autonics

ROTARY ENCODER(INCREMENTAL TYPE) E40S/E40H/E40HB/E80H SERIES

M A N U A L



Thank you very much for selecting Autonics products.
For your safety, please read the following before using.

Caution for your safety

- Please keep these instructions and review them before using this unit.
- Please observe the cautions that follow:
 - Warning** Serious injury may result if instructions are not followed.
 - Caution** Product may be damaged, or injury may result if instructions are not followed.
- The following is an explanation of the symbols used in the operation manual.
 - Warning** Injury or danger may occur under special conditions.

Warning

- When use this unit for controlling highly affective equipment to human or properties. (Medical instrument, Vehicles, Train, Airplane, combustion apparatus, entertainment etc.), it requires installing a fail safety device. It may cause serious human injury or a fire, property.

Caution

- Do not drop water or oil on this unit. It may cause damage or miscontrol due to malfunction.
- Please observe voltage rating. It may shorten the life cycle or damage to the product.
- Please check the polarity of power and wrong wiring. It may result in damage to this unit.
- Do not short circuit the load. It may result in damage to this unit.

Outline

This unit is very useful to control length, angle and position by converting revolution value of shaft into number of pulse as an optical incremental Encoder.

Ordering information

Series	Shaft diameter	Pulse/1Revolution	Output phase	Output	Power supply	Cable
E40S	φ6mm φ8mm	+1, +2, +5, 10, +12, 15, 20, 23, 25, 30, 35, 40, 45, 50, 60, 75, 100, 120, 125, 150,	2:A, B 3:A, B, Z 4:A, \bar{A} , B, \bar{B} 6:A, \bar{A} , B, \bar{B} , Z, \bar{Z}	T:Totem pole output N:NPN open collector output V:Voltage output L:Line driver output (The power is only for 5VDC)	5 :5VDC ±5% 24:12~24VDC ±5%	No mark: Normal type *C:Cable outgoing connector type
E40H (HB: Built-in type)	φ6mm φ8mm φ10mm φ12mm	192, 200, 240, 250, 256, 300, 360, 400, 500, 512, 600, 800, 1000, 1024, 1200, 1500, 1800, 2000, 2048, 2500, 3000, 3600, 5000	3:A, B, Z 6:A, \bar{A} , B, \bar{B} , Z, \bar{Z}			
E80H	φ30mm φ32mm	60, 100, 360, 500, 512, 1024, 3200	3:A, B, Z 6:A, \bar{A} , B, \bar{B} , Z, \bar{Z}			

* * indicates the standard specification of diameters.
* 1, 2, 5, 12 P/R are output A, B phase only. (But Line Driver output A, \bar{A} , B, \bar{B} phase)
* Cable length : 250mm

Control output diagram

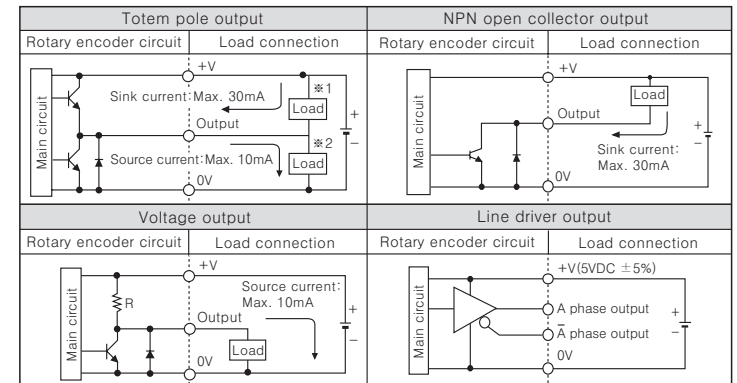

* The output circuit of A, B, Z phase are the same. (Line driver output is A, \bar{A} , B, \bar{B} , Z, \bar{Z})
* Totem pole output can be used for NPN open collector type(*1) or voltage output type(*2).
* The above specification are changeable without notice anytime.

Specifications

Item	φ40mm Shaft type Incremental Rotary encoder	φ40mm Hollow shaft type Incremental Rotary encoder	φ40mm Built-in type Incremental Rotary encoder	φ80mm Hollow shaft type Incremental Rotary encoder
Model	Totem pole output: E40S□□□□-T□□ NPN open collector output: E40S□□□□-N□□ Voltage output: E40S□□□□-V□□ Line driver output: E40S□□□□-L□□	Totem pole output: E40H□□□□-T□□ NPN open collector output: E40H□□□□-N□□ Voltage output: E40H□□□□-V□□ Line driver output: E40H□□□□-L□□	Totem pole output: E40HB□□□□-T□□ NPN open collector output: E40HB□□□□-N□□ Voltage output: E40HB□□□□-V□□ Line driver output: E40HB□□□□-L□□	Totem pole output: E80H□□□□-T□□ NPN open collector output: E80H□□□□-N□□ Voltage output: E80H□□□□-V□□ Line driver output: E80H□□□□-L□□
Resolution(P/R)	*1, +2, +5, 10, +12, 15, 20, 23, 25, 30, 35, 40, 45, 50, 60, 75, 100, 120, 125, 150, 192, 200, 240, 250, 256, 300, 360, 400, 500, 512, 600, 800, 1000, 1024, 1200, 1500, 1800, 2000, 2048, 2500, 3000, 3600, 5000 (Not indicated type is available to customize)			60, 100, 360, 500, 512, 1024, 3200
Output phase	(Note1) A, B, Z phase (Line driver output : A, \bar{A} , B, \bar{B} , Z, \bar{Z} phase)			
Phase difference of output	Output between A and B phase : $\frac{T}{4} \pm \frac{T}{8}$ (T=1cycle of A phase)			
Electrical specification	Control output	• Low \Rightarrow Load current:Max. 30mA, Residual voltage:Max. 0.4VDC • High \Rightarrow Load current:Max. 10mA, Output voltage(Power voltage 5VDC):Min. (Power voltage-2.0)VDC, Output voltage(Power voltage 12~24VDC): Min. (Power voltage-3.0)VDC Load current : Max. 30mA, Residual voltage : Max. 0.4VDC • Low \Rightarrow Load current : Max. 20mA, Residual voltage : Max. 0.5VDC • High \Rightarrow Load current : Max. -20mA, Output voltage : Min. 2.5VDC		
	Response time (Rise/Fall)	Max. 1 μ s (Cable length:2m, I sink=Max. 20mA)		
	Max. Response frequency	300kHz		
	Power supply	5VDC ±5% 12~24VDC ±5%		
Current consumption	Max. 80mA(disconnection of the load), Line driver output : Max. 50mA(disconnection of the load)			
Insulation resistance	Min. 100M Ω (at 500VDC between all terminals and case)			
Dielectric strength	750VAC/60Hz for 1 minute(Between all terminals and case)			
Connection	Cable outgoing type, 250mm Cable outgoing connector type			
Mechanical specification	Starting torque	Shaft type : Max. 40gf • cm(0.004N • m), Hollow type : Max. 50gf • cm(0.005N • m)		Max. 200gf • cm(0.02N • m)
	Moment of inertia	Max. 40g • cm ² (4×10 ⁻⁴ kg • m ²)		Max. 800g • cm ² (8×10 ⁻⁴ kg • m ²)
	Shaft loading	Radial:2kgf, Thrust:1kgf		Radial:5kgf, Thrust:2.5kgf
	Max. allowable revolution	(Note2) 5000rpm		3600rpm
Vibration	1.5mm amplitude at frequency of 10 ~ 55Hz in each of X, Y, Z directions for 2 hours			
Shock	Max. 50G			Max. 75G
Ambient temperature	-10 ~ 70°C(at non-freezing status), Storage : -25 ~ 85°C			
Ambient humidity	35 ~ 85%RH, Storage : 35~90%RH			
Protection	IP50 (IEC standard)			
Cable	φ5mm, 5P, Length:2m, Shield cable(Line driver output: φ5mm, 8P)			
Accessory	φ6mm coupling(Standard), φ8mm coupling(Optional)		Bracket	
Weight	Approx. 120g			Approx. 560g
Approval	CE (Except Line driver output)			

* (Note 1) 1, 2, 5 12 P/R are output A and B phase only. (But Line driver output : A, \bar{A} , B, \bar{B} phase)
* (Note 2) Max. allowable revolution \geq Max. response revolution 【Max. response revolution(rpm) = $\frac{\text{Max. response frequency}}{\text{Resolution}} \times 60 \text{ sec}$ 】
Please select the resolution to make lower max. revolution than max. allowable revolution.

Dimensions

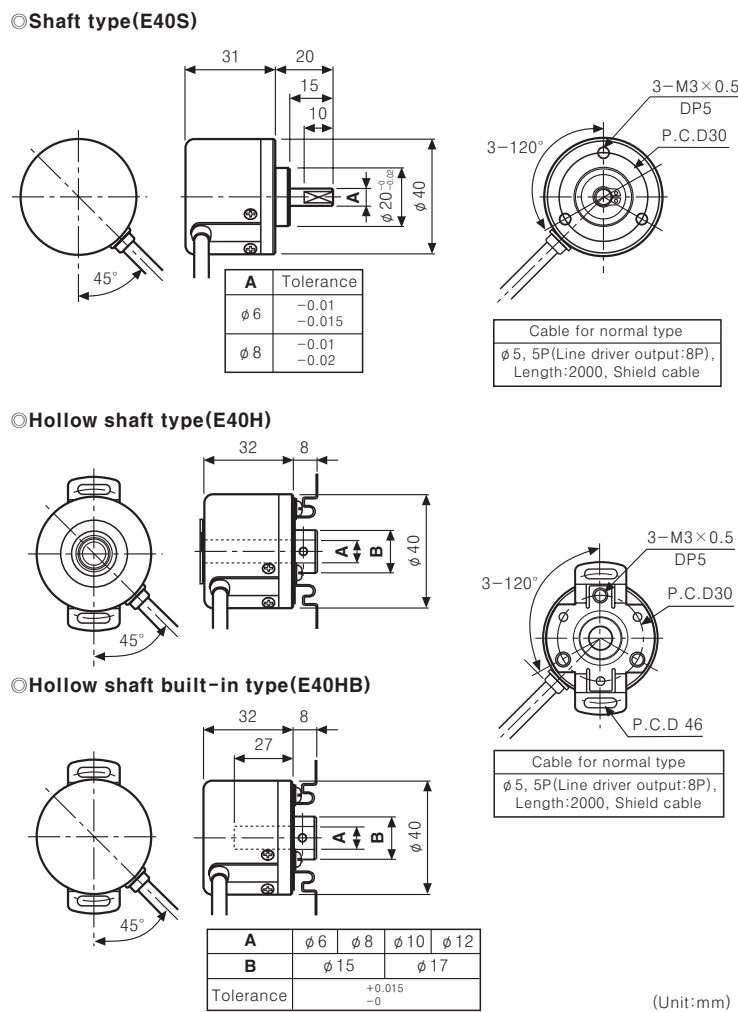

Hollow shaft type(E80H)

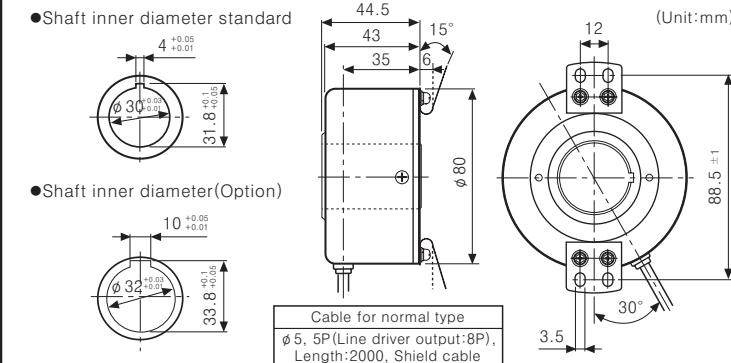

Bracket

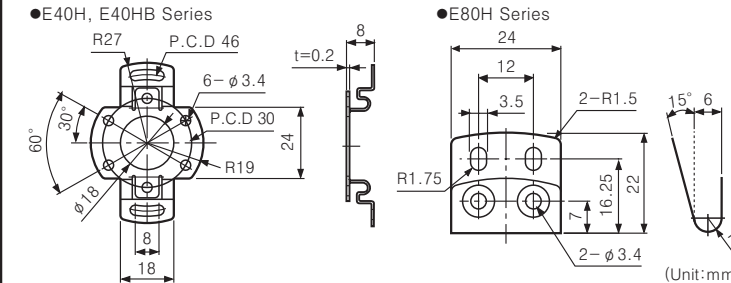

Coupling(E40S Series)

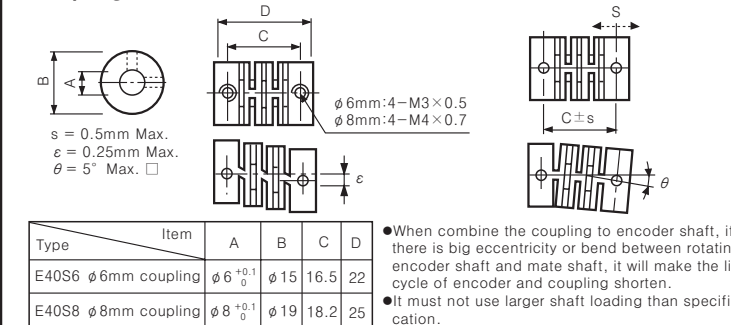

Connections

Normal type

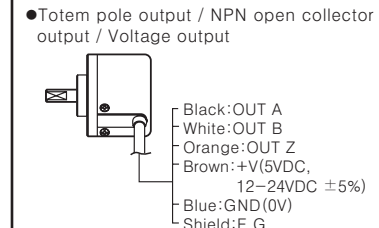

Line driver output

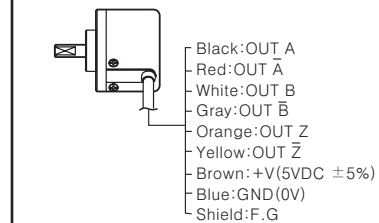

* Unused wires must be insulated.
* The body of encoder is connected to a shield.

Cable outgoing connector type

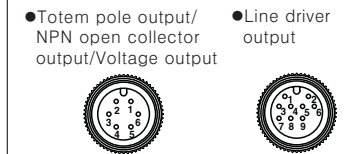

Totem pole output / NPN open collector output / Voltage output			Line driver output		
Pin No	Cable color	Function	Pin No	Cable color	Function
①	Black	OUT A	①	Black	OUT A
②	White	OUT B	②	Red	OUT \bar{A}
③	Orange	OUT Z	③	Brown	+V
④	Brown	+V	④	Blue	GND
⑤	Blue	GND	⑤	White	OUT B
⑥	Shield	F.G	⑥	Gray	OUT \bar{B}
			⑦	Orange	OUT Z
			⑧	Yellow	OUT \bar{Z}
			⑨	Shield	F.G

Output waveform

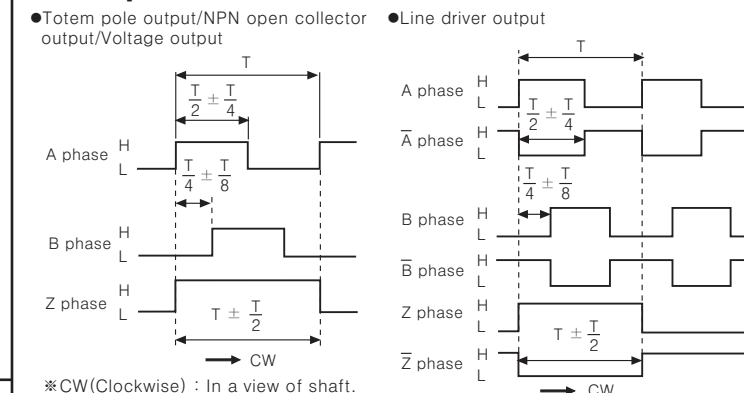

* CW(Clockwise) : In a view of shaft.

Caution for using

- Installation
 - This unit is consisted of precision components. Therefore please treat this product carefully.
 - When you install this unit, if eccentricity and deflection angle are larger, it may shorten the life cycle of this unit.
- Environment
 - Please do not use this unit with below environment, it results in malfunction.
 - Place where this unit or component may be damaged by strong vibration or impact.
 - Place where there are lots of flammable or corrosive gases.
 - Place where strong magnet field or electric noise are occurred.
 - Place where is beyond of rating temperature or humidity.
 - Place where strong acids or alkali near by.
 - Place where there is the direct ray of the sun.
- Vibration and Impact
 - When the strong impact loads on this unit, the error pulse may occur as if the slit is revolving.
 - Therefore please fix bracket firmly when mount this unit, because Rotary encoder with high resolution can be easily affected by impact.
- Wire connection
 - Do not draw the wire with over 30N strength after wiring.
 - When a high voltage or power line pass near by the encoder cable, be sure to wire the encoder cable in separated conduit to prevent malfunction.
 - When extend the cable, please use it after checking the cable and response frequency due to increment of residual voltage or distortion of waveform can be easily occurred. (Preferable shortest distance for operating)
 - Shield wire must be connected to F.G terminal.

* It may cause malfunction if above instructions are not followed.

Major products

- PROXIMITY SENSOR
- AREA SENSOR
- DOOR/DOOR SIDE SENSOR
- PRESSURE SENSOR
- ROTARY ENCODER
- COUNTER
- TIMER
- TEMPERATURE CONTROLLER
- TEMPERATURE/HUMIDITY TRANSDUCER
- POWER CONTROLLER
- PANEL METER
- TACHO/LINE SPEED/PULSE METER
- DISPLAY UNIT
- SENSOR CONTROLLER
- SWITCHING POWER SUPPLY
- GRAPHIC PANEL
- 5-PHASE STEPPING MOTOR & DRIVER & CONTROLLER
- LASER MARKING SYSTEM(CO₂, Nd:YAG)

Autonics Corporation
http://www.autonics.com
Global Partner for IA

HEADQUARTERS :
41-5, Yongdang-ri, Ulsangng-eup, Yangsan-si, Gyeongnam, 626-847, Korea

OVERSEAS SALES :
Bldg. 402 3rd Fl., Bucheon Techno Park, 193, Yaksdae-dong, Wonmi-gu, Bucheon-si, Gyeonggi-do, 420-734, Korea
TEL:82-32-610-2730 / FAX:82-32-329-0728
E-mail : sales@autonics.com