

Autonics
ROTARY ENCODER(INCREMENTAL TYPE)
E20 SERIES

M A N U A L



Thank you very much for selecting Autonics products.
For your safety, please read the following before using.

Caution for your safety

- *Please keep these instructions and review them before using this unit.
- *Please observe the cautions that follow;
- Warning** Serious injury may result if instructions are not followed.
- Caution** Product may be damaged, or injury may result if instructions are not followed.
- *The following is an explanation of the symbols used in the operation manual.
 ⚠caution: Injury or danger may occur under special conditions.

Warning

1. If this unit is used to control machineries (Medical equipment, vehicle, train, airplane, combustion apparatus, entertainment, processing and transportation equipment, elevator and various safety device etc.) enabling to effect on human or property, it is required to install fail-safe device.
 It may cause a fire, serious human injury and damage on property.

Caution

- 1. It should be protected from water or oil.**
 It may cause damage or miscontrol due to malfunction.
- 2. Please observe the voltage range.**
 It may shorten the life cycle or damage to the product.
- 3. Please check the polarity of power and wrong wiring.**
 It may result in damage to this unit.
- 4. Do not short circuit the load.**
 It may result in damage to this unit.

Outline

It is a optical incremental type of rotary encoder useful to control length, angle and position by convert rotation amount of rotation axis into the number of pulse and output.

Ordering information

E20S	2	360	3	N	12	R
Series	Shaft diameter	Pulse/Revolution	Output phase	Output type	Power supply	Cable outgoing direction
E20S Diameter φ20mm, Shaft type	φ2mm	100, 200, 360	3 : A, B, Z 6 : A, B, Z A, B, Z	N : NPN open collector output V : Voltage output L : Line driver output	5 : 5VDC±5% 12 : 12VDC±5%	R : Rear S : Side
E20HB Diameter φ20mm, Built-in type	φ2mm, φ2.5mm, φ3mm			*The power of Line driver is only for 5VDC.		

Control output diagram

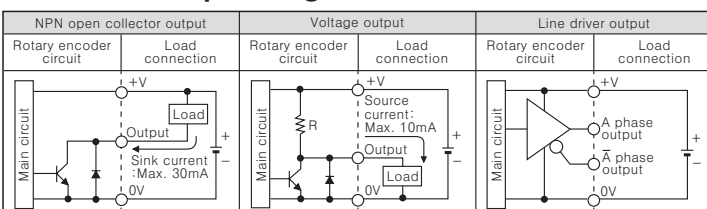

*The output circuit of A, B, Z phase are the same. (Line driver output is A, A-bar, B, B-bar, Z, Z-bar)

*The above specifications are changeable at anytime without notice.

Specifications

Item	φ20mm Shaft type Incremental Rotary Encoder	φ20mm Built-in type Incremental Rotary Encoder
Model	E20S2-□-3-N-□-R, S E20S2-□-3-V-□-R, S E20S2-□-6-L-5-R, S	E20HB□-□-3-N-□-R, S E20HB□-□-3-V-□-R, S E20HB□-□-6-L-5-R, S
Resolution(P/R)	100, 200, 360 (Not indicated pulse and output type is customizable.)	
Output phase	A, B, Z phase (Line driver output A, A-bar, B, B-bar, Z, Z-bar phase)	
Phase difference of output	Phase difference between A and B : $\frac{T}{4} \pm \frac{T}{8}$ (T=1 cycle of A phase)	
Control output	NPN open collector output	Load current : Max. 30mA, Residual voltage : Max. 0.4VDC
	Voltage output	Load current : Max. 10mA, Residual voltage : Max. 0.4VDC
	Line driver output	• Low Ⓢ Load current : Max. 20mA, Residual : Max. 0.5VDC • High Ⓢ Load current : Max. -20mA, Output voltage : Min. 2.5VDC
Electrical specification	Response time (Rise/Fall)	Max. 1μs
	Voltage output	Max. 1μs
	Line driver output	Max. 0.5μs
Max. Response frequency	100kHz	
Power supply	• 5VDC ±5% • 12VDC ±5%	
Current consumption	Max. 60mA(disconnection of the load), Line driver output: Max. 50mA(disconnection of the load)	
Insulation resistance	Min. 100MΩ(at 500VDC between all terminals and case)	
Dielectric strength	500VAC 50/60Hz for 1 minute(Between all terminals and case)	
Connection	Outgoing cable type(Rear / Side)	
Mechanical specification	Starting torque	Max. 5gf · cm(5 × 10 ⁻⁴ N · m)
	Moment of inertia	Max. 0.5g · cm ² (5 × 10 ⁻⁸ kg · m ²)
	Shaft loading	Radial : 200gf, Thrust : 200gf
	Max. allowable revolution	(Note1) 6000rpm
Vibration	1.5mm amplitude at frequency of 10 to 55Hz in each of X, Y, Z directions for 2 hours	
Shock	Max. 50G	
Ambient temperature	-10 to 70°C(at non-freezing status), Storage : -20 to 80°C	
Ambient humidity	35 to 85%RH, Storage : 35 to 90%RH	
Protection	IP50(IEC standard)	
Cable	φ3mm, 5P(Line driver output : 8P), Length:1m, Shield cable	
Accessory	φ2mm Coupling(Shaft type), Bracket(Built-in type)	
Approval	CE(Except Line driver output)	
Unit weight	Approx. 35g	

* (Note1) Max. allowable revolution ≥ Max. response revolution

$$\text{[Max. response revolution(rpm)} = \frac{\text{Max. response frequency}}{\text{Resolution}} \times 60 \text{ sec]}$$
 Please select the resolution to make lower max. revolution than max. allowable revolution.

Dimension

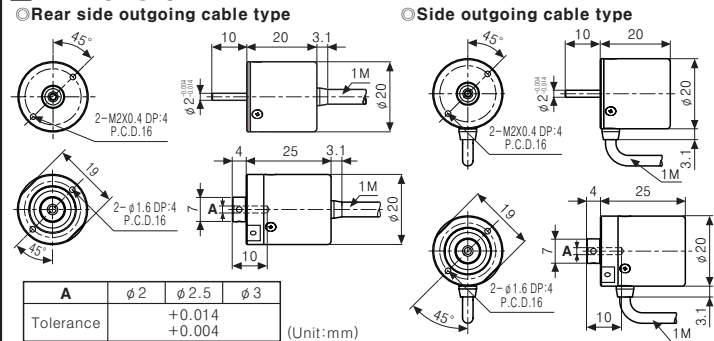

Accessory

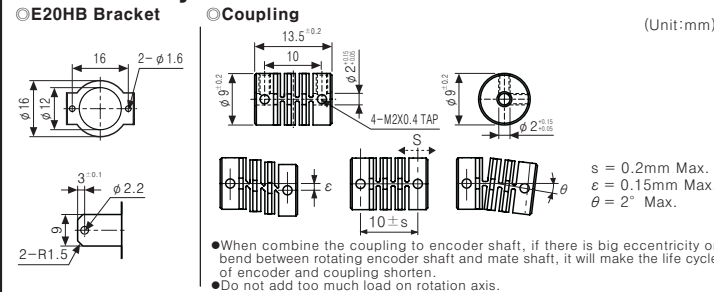

Connections

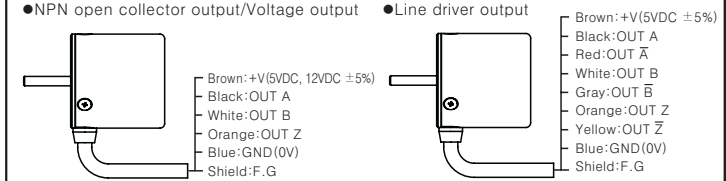

Output waveform

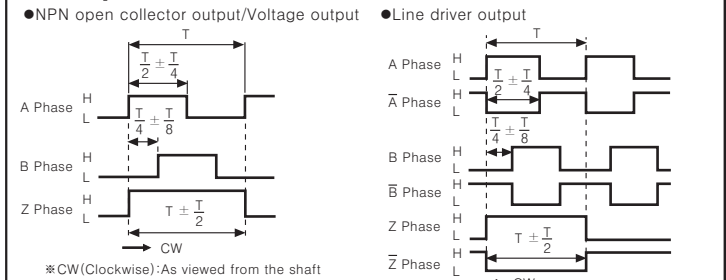

Caution for using

- Installation
 - This unit is consisted of precision components. Therefore please treat this product carefully.
 - For the installation, please check the assembly dimension of counterpart, then try not to occur the offset between shaft hole and the object. It might shorten the life cycle of the product.
 - Do not put strong impact when insert coupling into shaft.
 - Fix the unit or coupling by wrench under 0.15N · m of torque.
- For using
 - Please connect shield wire to F.G terminal. (Encoder+Motor+Panel F.G.)
 - Do not connect and cut circuit off during power on. It may result in damage to this unit.
 - When the power source is a Switching Power, please install the surge absorber in power line and wire should be short in order not to be influenced by noise.
 - Please apply 5VDC to encoder when use Line Driver type.
- Environment
 - Please do not use this unit with below environment, it results in malfunction.
 - Place where this unit or component may be damaged by strong vibration or impact.
 - Place where there are lots of flammable or corrosive gases.
 - Place where strong magnet field or electric noise are occurred.
 - Place where is beyond of rating temperature or humidity.
 - Place where strong acids or alkali near by.
- Vibration and Impact
 - When the strong impact loads on this unit, the error pulse may occur as if the slit is revolving.
 - Please fix this unit firmly when mount it in order to avoid malfunction by residual vibration.
- Wire connection
 - Do not pull out the unit after connection with over the rated force(15N).
 - If use the cable of encoder and high voltage line or power cable in the same conduit, it may cause a malfunction or mechanical trouble. Please wire separately or use separated conduit.
 - Please check wire and response frequency when extend wire because of distortion of waveform or residual voltage increment etc by line resistance or capacity between lines.

*It may cause malfunction if above instructions are not followed.

Major products

- PROXIMITY SENSOR
- PHOTOELECTRIC SENSOR
- AREA SENSOR
- FIBER OPTIC SENSOR
- DOOR/DOOR SIDE SENSOR
- PRESSURE SENSOR
- ROTARY ENCODER
- SENSOR CONTROLLER
- SWITCHING POWER SUPPLY
- TEMPERATURE CONTROLLER
- TEMPERATURE/HUMIDITY TRANSDUCER
- POWER CONTROLLER
- RECORDER
- TACHOMETER/PULSE(RATE) METER
- PANEL METER
- INDICATOR
- SIGNAL CONVERTER
- COUNTER
- TIMER
- DISPLAY UNIT
- GRAPHIC PANEL
- STEPPING MOTOR & DRIVER
- MOTION CONTROLLER

Autonics Corporation
<http://www.autonics.com>
 Satisfiable Partner For Factory Automation

HEAD QUARTERS
 41-5, Yongdang-dong, Yangsan-si, Gyeongsangnam, 628-847, Korea

OVERSEAS SALES
 Bldg. 402 3rd Fl., Bucheon Techno Park, 193, Yaksae-dong, Wonmi-gu, Bucheon-si, Gyeonggi-do, 420-724, Korea
 TEL: 82-32-610-2730 / FAX: 82-32-329-0728
 E-mail : sales@autonics.com

The proposal of a product improvement and development : Product@autonics.com