

# Autonics PHOTOELECTRIC SENSOR BR SERIES

## M A N U A L



Thank you very much for selecting Autonics products.  
**For your safety, please read the following before using.**

### Caution for your safety

- ※ Please keep these instructions and review them before using this unit.
- ※ Please observe the cautions that follow:
- Warning** Serious injury may result if instructions are not followed.
- Caution** Product may be damaged, or injury may result if instructions are not followed.
- ※ The following is an explanation of the symbols used in the operation manual.
- ⚠ Injury or danger may occur under special conditions.

### Warning

- In case of using this unit with machineries(Nuclear power control medical equipment, vehicle, train, airplane, combustion apparatus, entertainment or safety device etc), it requires installing fail-safe device, or contact us for information on type required.
- It may result in serious damage, fire or human injury.

### Caution

- This unit shall not be used outdoors.  
It might shorten the life cycle of the product or give an electric shock.
- Do not use this unit in place where there is flammable or explosive gas.  
It may cause a fire or explosion.
- Please observe voltage rating and do not supply AC power.  
It may shorten the life cycle or damage to the product.
- Please check the polarity of power and wrong wiring.  
It may result in damage to this unit.
- Do not use this unit in place where there is vibration or impact.  
It may result in product damage.
- In cleaning the unit, do not use water or an oil-based detergent.  
It might cause an electric shock or fire that will result in damage to the product.

### Ordering information

BR P 100 - T D T □ □ - P	
Control output	No-mark NPN open collector output P PNP open collector output
Appearance	1 Emitter
	2 Receiver
	No-mark Single body type
Operation mode (Through-beam)	D Dark ON L Light ON
Optic properties (Diffuse reflective, Retroreflective)	N Spot type No-mark Standard type
Output	Solid-state output(TR)
Power supply	DC power
Detecting type	T Through-beam
	D Diffuse reflective M Retroreflective
Detecting distance	M Unit:m No-mark Unit:mm
	P Plastic No-mark Metal
Photo sensor	BR Series name

### Operation mode

Operation mode	Light ON mode	Dark ON mode
Receiver operation	Received light Interrupted light	
Operation indicator (LED)	ON OFF	ON OFF
Output TR	ON OFF	ON OFF

Note)1. The control output TR will be held OFF for 0.5 sec. after supplied power in order to prevent malfunction of this photoelectric sensor(Diffuse reflective, retroreflective).  
 2. If the control output terminal is short-circuited or flow beyond rating current, the control signal will not be output normally due to protection circuit.

※ The above specifications are subject to change without notice.

### Specifications

Type	Diffuse reflective				Retroreflective		Through-beam	
Model	BRP100 -DDT	BR100 -DDT	BRP200 -DDTN	BR200 -DDTN	BRP400 -DDT	BR400 -DDT	BRP3M -MDT	BR3M -MDT
	BRP100 -DDT-P	BR100 -DDT-P	BRP200 -DDTN-P	BR200 -DDTN-P	BRP400 -DDT-P	BR400 -DDT-P	BRP3M -MDT-P	BR3M -MDT-P
Detecting distance	100mm (•1)	200mm (•2)	400mm (•2)	0.1~3m (•3)	4m, 20m			
Detecting target	Transparent, Translucent, Opaque materials				Opaque materials of min. ϕ60		Opaque materials of min. ϕ15	
Hysteresis	Max. 20% at rated setting distance							
Response time	Max. 1ms							
Power supply	12~24VDC ±10%(Ripple P-P : Max. 10%)							
Current consumption	Max. 45mA							
Light source	Infrared LED(940nm)		Infrared LED(850nm)		Red LED(660nm)		Infrared LED(850nm)	
Sensitivity adjustment	Adjustable (VR)				Fixed		Fixed	
Operation mode	Selectable Light ON or Dark ON by control wire(White)				Dark ON fixed		Light ON fixed	
Control	• NPN open collector output (≡ Load voltage:Max. 30V, Load current:Max. 200mA, Residual voltage:Max. 1V output) • PNP open collector output (≡ Output voltage:Min. power voltage-2.5V, Load current Max. 200mA)							
Protection circuit	Short-circuit protection, Reverse polarity protection							
Indication	Operation indicator:Red LED, Power indicator(BR4M-TDT1, BR20M-TDT1)							
Connection	Outgoing cable							
Insulation resistance	Min. 20MΩ (at 500VDC mega)							
Noise strength	±240V the square wave noise(pulse width:1μs) by the noise simulator							
Dielectric strength	1000VAC 50/60Hz for 1 minute							
Vibration	1.5mm amplitude at frequency of 10 to 55Hz in each of X, Y, Z directions for 2 hours							
Shock	500m/s <sup>2</sup> (50G) in X, Y, Z directions for 3 times							
Ambient illumination	Sunlight:Max. 11,000lx, Incandescent lamp:Max. 3,000lx(Receiver illumination)							
Ambient temperature	-10 to 60°C (non-freezing condition), Storage:-25 to 70°C							
Ambient humidity	35 to 85%RH, Storage:35 to 85%RH							
Protection	IP66(IEC standard)							
Material	Case: PA (Nylon, Black) Lens: PC	Case: Brass, Cr-plate (Nylon, Black) Lens: PC	Case: PA (Nylon, Black) Lens: PC	Case: Brass, Cr-plate (Nylon, Black) Lens: PC	Case: PA (Nylon, Black) Lens: PC	Case: Brass, Cr-plate (Nylon, Black) Lens: PC	Case: PA (Nylon, Black) Lens: PMMA	Case: Brass, Cr-plate (Nylon, Black) Lens: PMMA
Cable	ϕ5, 4P, Length:2m				Emitter-ϕ5, 2P, Length:2m Receiver-ϕ5, 3P, Length:2m			
Accessories	Separate	Drivers				Drivers, Mirror(MS-2)		
	Common	BR : Mounting Nuts, Washer / BRP : Mounting Nuts						
Weight	Approx. 100g	Approx. 120g	Approx. 100g	Approx. 120g	Approx. 100g	Approx. 120g	Approx. 300g	

※ (•1) Non-glossy white paper 50×50mm (•2) Non-glossy white paper 100×100mm.  
 (•3) Detecting distance and detecting target for Retroreflective type is rated based on mirror(MS-2). Detecting distance indicates possible reflective mirror setting range. Sensing under 0.1m is also available.

### Dimensions

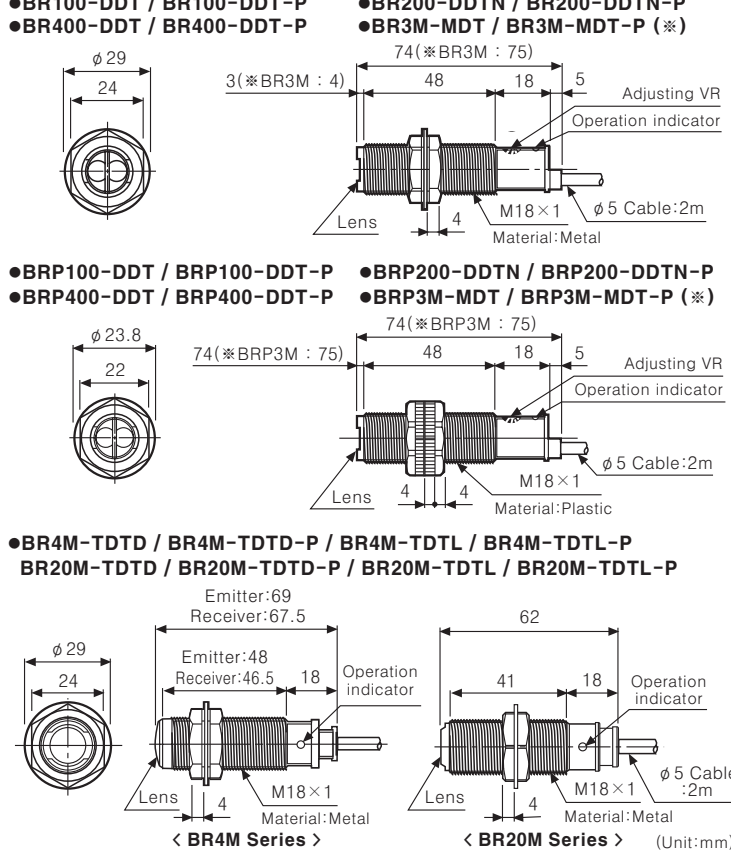

### Connections

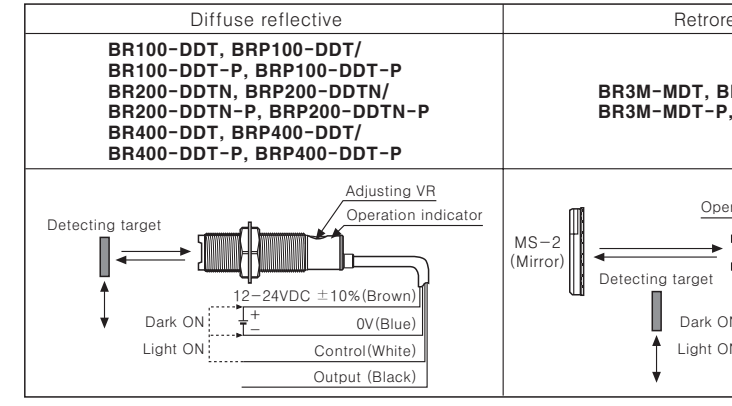

### Control output circuit diagram

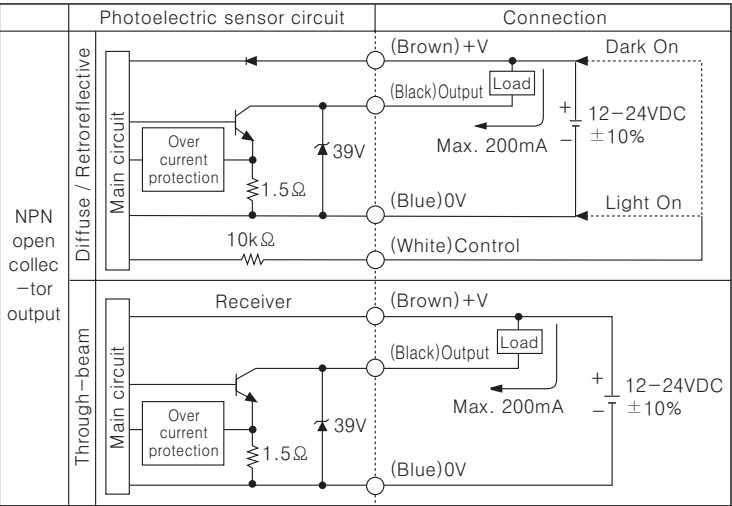

### Mounting & Adjustment

Please supply the power to the sensor, after setting the emitter and the receiver in face to face, and then adjust an optical axis and the sensitivity as follow:

- Diffuse Reflective type**
  - Even though the sensor is still available at the max. sensitivity position, it is recommended to adjust sensor sensitivity with considering existence of reflective material in background.
  - Set the target at a position to be detected by the beam, then turn the adjuster until point (a) which the indicator turns on from Min. position of the adjuster.
  - Take the target out of the photoelectric sensor, then turn the adjuster until point (b) which the indicator turns on, if the indicator does not turn on, max. position is point (b).
  - Set the adjuster at the center of two switching point (a), (b).

※ The detecting distance indicated in the specification chart is for non-glossy white paper 100×100mm or 50×50mm. It is subject to change depending on the size of sensing target, surface status and gloss, etc.
- Retroreflective**
  - Set the sensor and mirror (MS-2) in opposite each other and supply the power.
  - Check stable indicator operation range with moving both sensor and mirror up / down and right / left and adjust the position in the middle.
  - After finishing position adjustment, check whether the sensor is operated normally with placing a sensing target on optical axis.

※ In case of using multiple sensors in parallel, keep each sensor's distance min. 30cm.  
 ※ In case sensing target has higher reflectivity than non-glassy white paper, the sensor may cause malfunction due to direct reflected light from the target. Keep certain distance between a sensor and sensing target, or install the sensor with making sensing target's surface inclining 30° ~ 45° to photo sensor's optical axis.
- Through-Beam type**
  - Set the receiver and emitter in opposite each other and supply the power.
  - Check stable indicator operation range with moving both receiver and emitter up / down and right / left and adjust the position in the middle.
  - After finishing position adjustment, check whether the sensor is operated normally with placing a sensing target on optical axis.

※ If the detecting target is translucent body or smaller than ϕ15, it might not detect the target cause light passed.

### Caution for using

- Intercept a strong source of light as like sunlight, spotlight within inclination angle range of photoelectric sensor.
- The photoelectric sensor may cause malfunction under the fluorescent lamp light, so be sure to use cut-off light with panel.
- When more than 2 sets of Through-beam type sensor are used closely, it might cause interference each other. Be sure to put enough space between them in order to avoid malfunction.
- When more than 2 sets of diffuse reflection type are installed adjacently, it can be occurred malfunction by light beam from the other target. So it must be installed at an enough interval.
- If photoelectric sensor is installed at flat part, it might cause malfunction by reflection light from flat part. Be sure to put space between photoelectric sensor and ground.
- When wire the photoelectric sensor with high voltage line, power line in the same conduit, it may cause malfunction or mechanical trouble. Therefore please wire separately or use different conduit.
- Avoid installing the unit as following place.  
Corrosive gas, oil or dust, strong flux, noise, sunlight, strong alkali, acid.
- In case of connect DC relay as inductive load to output, please remove surges by using diode or varistor.
- The photoelectric sensor cable shall be used as short as possible, because it may cause malfunction by noise through the cable.
- When it is stained by dirt at lens, please clean the lens with dry cloth, but don't use an organic materials such as alkali, acid, chromic acid.
- When use switching power supply as the source of supplying power, F.G terminal shall be good earth ground and condenser for removing noise shall be installed between 0V and F.G terminal.

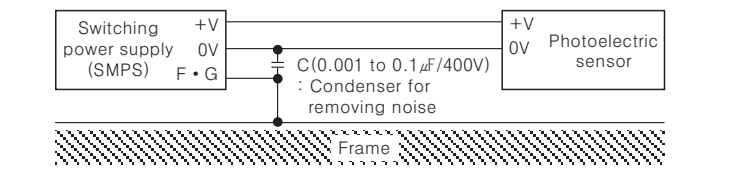

※ It may cause malfunction if above instructions are not followed.

### Major products

- Proximity sensors
- Area sensors
- Door/Door side sensors
- Rotary encoders
- Switching power supply
- Temperature controllers
- Temperature/Humidity transducers
- Power controllers
- Recorders
- Tachometer/Pulse(Rate) meters
- Panel meters
- Signal converters
- Timers
- Display units
- Graphic/Logic panel
- Stepping Motors & Drivers & Motion controllers
- Photoelectric sensors
- Fiber optic sensors
- Pressure sensors
- Sensor controllers
- Indicators
- Counters

**Autonics Corporation**  
<http://www.autonics.com>

**Satisfiable Partner For Factory Automation**

**HEAD QUARTERS :**  
 41-5, Yongdang-dong, Yangsan-si, Gyeongnam, 626-847, Korea  
**OVERSEAS SALES :**  
 Bldg. 402 3rd Fl., Buecheon Techno Park, 193, Yaksae-dong, Wonmi-gu, Buecheon-si, Gyeonggi-do, 420-734, Korea  
 TEL: 82-32-610-2780 / FAX: 82-32-329-0728  
 E-mail : sales@autonics.com

The proposal of a product improvement and development : Product@autonics.com

EP-KE-08-0050H