

Autonics

**ANALOG TIMER
AT8SDN**

M A N U A L



Thank you very much for selecting Autonics products.
For your safety, please read the following before using.

Caution for your safety

- ※ Please keep these instructions and review them before using this unit.
- ※ Please observe the cautions that follow;
- Warning** Serious injury may result if instructions are not followed.
- Caution** Product may be damaged, or injury may result if instructions are not followed.
- ※ The following is an explanation of the symbols used in the operation manual.
⚠ caution: Injury or danger may occur under special conditions.

Warning

- 1. In case of using this unit with machineries(Nuclear power control, medical equipment, vehicle, train, airplane, combustion apparatus, entertainment or safety device etc), it requires installing fail-safe device, or contact us for information required.**
It may result in serious damage, fire or human injury
- 2. This unit must be mounted on panel.**
It may give an electric shock.
- 3. Do not connect terminals when it is power on.**
It may give an electric shock.
- 4. Do not disassemble and modify this unit, when it requires. If needs, please contact us.**
It may give an electric shock and cause a fire.

Caution

- 1. This unit shall not be used outdoors.**
It might shorten the life cycle of the product or give an electric shock.
- 2. Please observe specification rating.**
It might shorten the life cycle of the product and cause a fire.
- 3. Do not use the load beyond rated switching capacity of Relay contact.**
It may cause insulation failure, contact melt, contact failure, relay broken, fire etc.
- 4. In cleaning the unit, do not use water or an organic solvents.**
It might cause an electric shock or fire that will result in damage to the product.
- 5. Do not use this unit at place where there are flammable or explosive gas, humidity, direct ray of the sun, radiant heat, vibration, impact etc.**
It may cause a fire of mechanical trouble.
- 6. Do not inflow dust or wire dregs into inside of this unit.**
It may cause a fire of mechanical trouble.

Ordering information

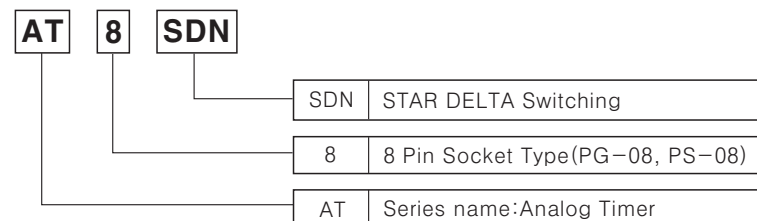

※ The above specification are changeable without notice anytime.

Dimensions

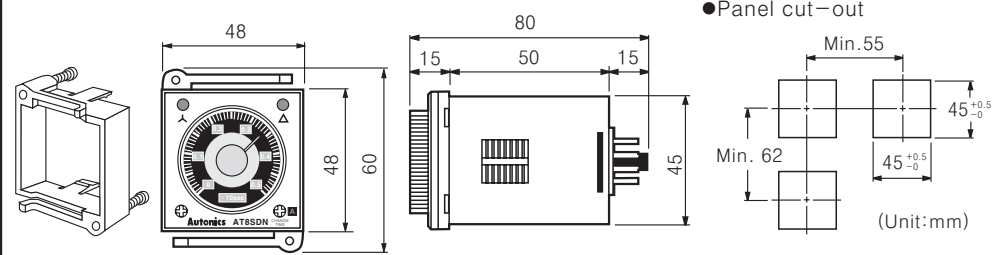

Front panel identification

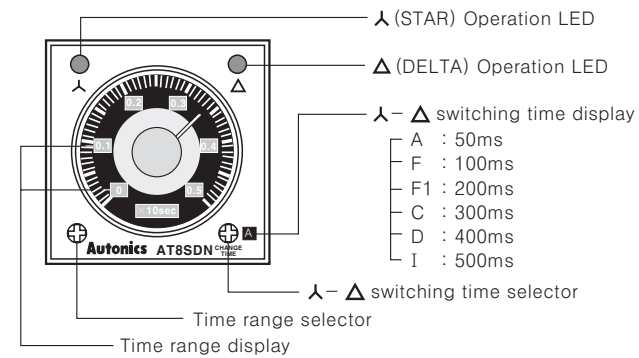

Specifications

Model	AT8SDN		
Operation	STAR-DELTA(⋈-Δ) switching		
Control time(T1) setting range	0.5sec to 100sec(Max. time)		
Power supply	<ul style="list-style-type: none"> • 24-240VAC(50/60Hz), 24-240VDC • 12VDC(Optional) 		
Allowable voltage range	90 to 110% of rated voltage□		
Power consumption	<ul style="list-style-type: none"> • 24-240VAC : Approx. 2.8VA, 24-240VDC : Approx. 1.3W • 12VDC : Approx. 0.5W 		
Return time□	Max. 100ms		
Control output□	Contact	Type	⋈contact:SPST(1a), Δcontact:SPST(1a)
	Capacity		250VAC 3A resistive load
Repeat error	Max. ±0.3%		
Setting error	Max. ±5% ±0.05sec.		
Voltage error	Max. ±0.5%		
Temperature error	Max. ±2%		
⋈-Δ switching time(T2) error	Max. ±25%		
Insulation resistance	Min. 100MΩ (at 500VDC)		
Dielectric strength	2000VAC 50/60Hz for 1 minute		
Noise strength	Square-wave noise by noise simulator, apply ±2kV in power input terminals		
Vibration	Mechanical	0.75mm amplitude at frequency of 10 to 55Hz in each of X, Y, Z directions for 1 hours	
	Malfunction	0.5mm amplitude at frequency of 10 to 55Hz in each of X, Y, Z directions for 10 minutes	
Shock	Mechanical	300m/s ² (Approx. 30G) 3 times at X, Y, Z direction	
	Malfunction	100m/s ² (Approx. 10G) 3 times at X, Y, Z direction	
Relay life cycle	Mechanical	Min. 10,000,000 times	
	Electrical	Min. 100,000 times(250VAC 3A resistive load)	
Ambient temperature	-10 to 55°C (at non-freezing status)		
Storage temperature	-25 to 65°C (at non-freezing status)		
Ambient humidity	35 to 85%RH		
Weight	Approx. 100g		

Connections

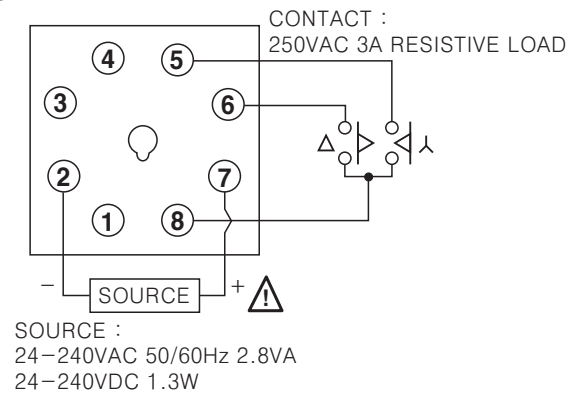

Operation and time specification

● Operation

⋈ contact will be ON at the same time as power supplied, Δ contact will be OFF when it reaches to T1 setting time then Δ contact will be ON after T2 switching time.
Δ contact will be OFF when cut off the power at the status of Δ contact is ON.

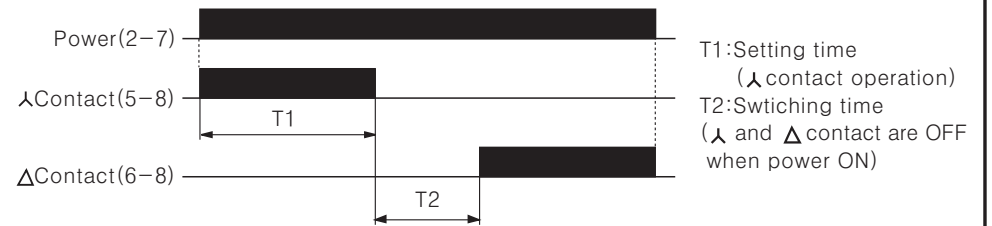

● Time specification

1. T1(Setting time)

Time range	Time unit	Time setting range
0.5	×10sec	0.5 to 5sec
1.0		1 to 10sec
5		5 to 50sec
10		10 to 100sec

2. T2(⋈-Δ Switching time)

Switching time symbols	A	F	F1	C	D	I
T2(⋈-Δ Switching time)	50ms	100ms	200ms	300ms	400ms	500ms

Caution for using

1. When apply the power, please apply rating power at the moment by switch, relay etc. Otherwise it might cause malfunction.
2. Do not use this product for long time. It may cause shorten life cycle of Timer due to heat inner electric component.
3. Please connect DC power input after checking polarity of power.
4. When supply the power to the Timer, connection as shown in (Fig.1). It might cause malfunction due to leakage current through R and C. Please connect R and C as shown in (Fig.2) to prevent malfunction.

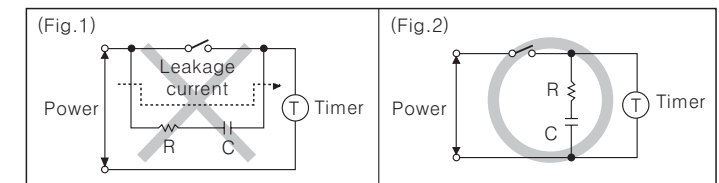

5. It might cause malfunction if change the setting time, time range or operation mode during unit operating. Please change the setting time, time range or operation mode after cut the power off.
6. When test dielectric voltage and insulation resistance of the control panel with this unit installed.
 - ① Please isolate this unit from the circuit of control panel.
 - ② Please make all terminals of this unit short-circuited.
7. Do not use this unit at below places.
 - ① Place where there are severe vibration or impact.
 - ② Place where strong alkalis or acids are used.
 - ③ Place where there are direct ray of the sun.
 - ④ Place where strong magnetic field or electric noise are generated.
8. Installation environment
 - ① It shall be used indoor
 - ② Altitude Max. 2000m
 - ③ Pollution Degree 2
 - ④ Installation Category II

※ It may cause malfunction if above instructions are not followed.

Main products

- COUNTER
- TIMER
- TEMPERATURE CONTROLLER
- PANEL METER
- TACHO/LINE SPEED/PULSE METER
- DISPLAY UNIT
- PROXIMITY SENSOR
- PHOTOELECTRIC SENSOR
- FIBER OPTIC SENSOR
- PRESSURE SENSOR
- ROTARY ENCODER
- SENSOR CONTROLLER
- POWER CONTROLLER
- STEPPING MOTOR & DRIVER & CONTROLLER
- LASER MARKING SYSTEM(CO₂, Nd:YAG)

Autonics Corporation
http://www.autonics.com

Satisfiable Partner For Factory Automation

■ HEADQUARTERS :
41-5, Yongdang-ri, Uingsang-eup, Yangsan-si, Gyeongnam, 626-847, Korea

■ INTERNATIONAL SALES :
Bldg. 402 3rd Fl., Bucheon Techno Park, 193, Yakdae-dong, Wonmi-gu, Bucheon-si, Gyeonggi-do, 420-734, Korea
TEL: 82-32-329-0722 / FAX: 82-32-329-0728
E-mail : sales@autonics.net