

Autonics

**INDUCTIVE LONG DISTANCE PROXIMITY SENSOR
AS80-50 SERIES**

M A N U A L



Thank you very much for selecting Autonics products.
For your safety, please read the following before using.

Caution for your safety

※ Please keep these instructions and review them before using this unit.

※ Please observe the cautions that follow;

Warning Serious injury may result if instructions are not followed.

Caution Product may be damaged, or injury may result if instructions are not followed.

※ The following is an explanation of the symbols used in the operation manual.
⚠ caution: Injury or danger may occur under special conditions.

Warning

1. In case of using this unit with machineries(Nuclear power control, medical equipment, vehicle, train, airplane, combustion apparatus, entertainment or safety device etc), it requires installing fail-safe device, or contact us for information on type required.

It may result in serious damage, fire or human injury.

Caution

1. Do not use this unit in place where there is flammable, explosive gas, chemical or strong alkalis, acids.

It may cause a fire or explosion.

2. Do not impact on this unit.

It may result in malfunction or damage to the product.

3. Do not apply AC power and observe specification rating.

It may result in serious damage to the product.

Ordering information

A S 80 - 50 D N3

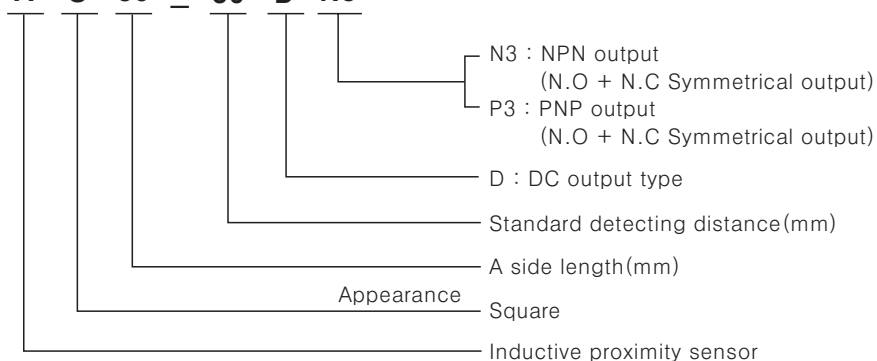

※ The above specification are changeable without notice anytime.

Specifications

Model□	AS80-50DN3	AS80-50DP3
Detecting distance	50mm ±10%	
Hysteresis	Max. 10% of detecting distance	
Standard detecting target	150×150×1mm(Iron)	
Setting distance	0 to 35mm	
Power supply (Operating voltage)	12-48VDC (10-65VDC)	
Current consumption	Max. 10mA	
Leakage current	—	
Response frequency	100Hz	
Residual voltage	Max. 1.8V□	
Affection by Temp.	±10% max. of detecting distance at +20°C within temperature range of -25 to 70°C	
Control output	200mA	
Insulation resistance	Min. 50MΩ (500VDC)□	
Dielectric strength	1500VAC 50/60Hz for 1 minute	
Vibration	1mm amplitude at frequency of 10 to 55Hz in each of X, Y, Z directions for 2 hours	
Shock	500m/s ² (50G) in X, Y, Z directions for 3 times	
Indicator□	Power indicator : Green LED, Operating indicator : Yellow LED	
Ambient temperature	-25 to +70°C (non-freezing condition)	
Storage temperature	-30 to +80°C (non-freezing condition)	
Ambient humidity	35 to 95%RH	
Protection circuit	Reverse polarity protection, Surge protection, Overload & short-circuit protection	
Protection□	IP67(IEC specification)□	
Weight	Approx. 470g	

Dimensions

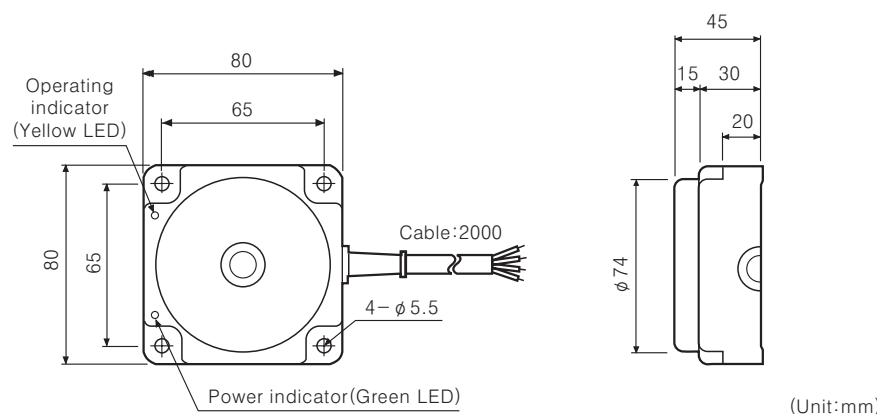

Control output diagram & Load operating

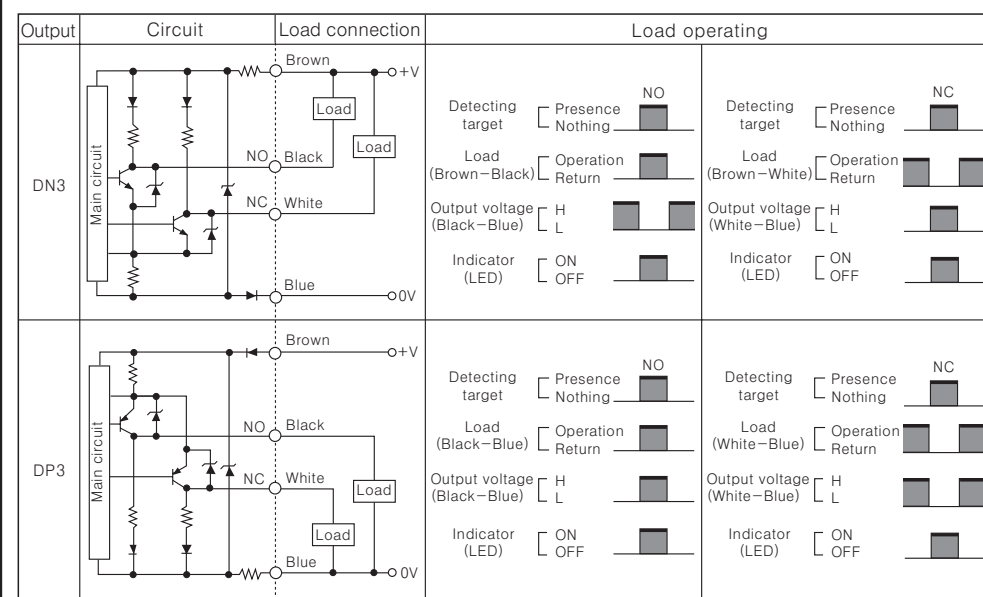

Mutual-interference & Influence by surrounding metals

○ Mutual-interference
When plural proximity sensors are mounted in a close row, malfunction of sensor may be caused due to mutual interference. Therefore, be sure to provide a minimum distance between the two sensors, as below charts.

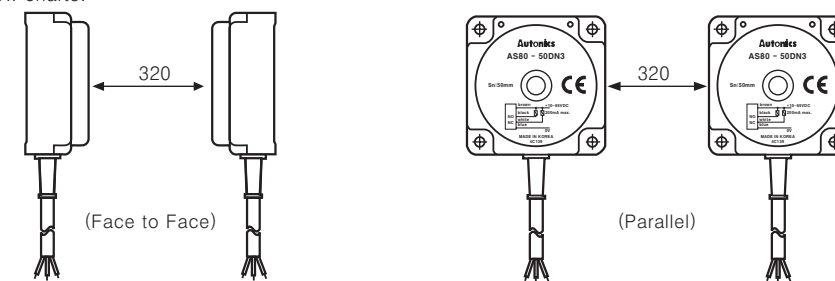

○ Influence by surrounding metals

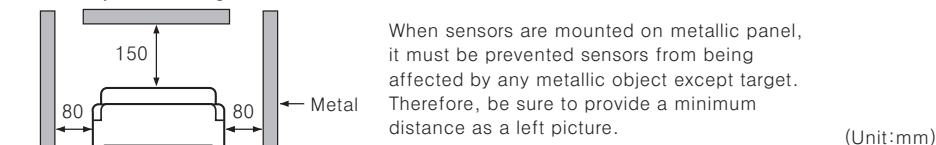

Setting distance

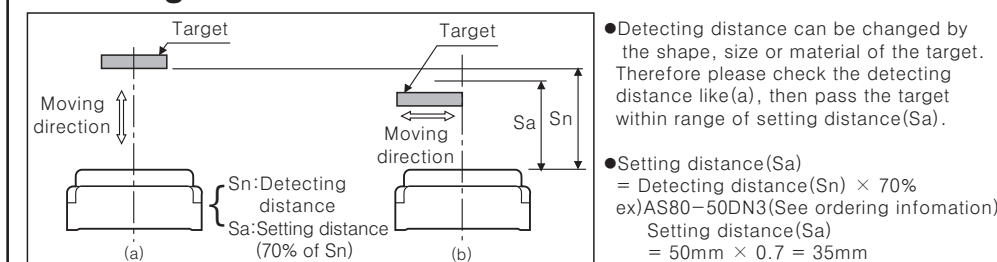

Caution for using

- This equipment shall not be used outdoors or beyond specified temperature range.
 - Do not load over than tensile strength of cord. (φ4:30N max., φ5:50N max.)
 - Do not use the same conduit with cord of this unit and electric power line or power line. Also avoid the same connection.
 - Tighten strength of installing bolts should be under 15kgf • cm.
 - Please check the voltage changes of power source in order not to excess rating power input.
 - Do not use this unit during transient time(80ms) after apply power.
 - It might result in damage to this product, if use automatic transformer. So please use insulated transformer.
 - Please make wire short as much as possible in order to avoid noise.
 - Be sure to cable as indicated specification on this product. If use wrong cable or bended cable, it shall not maintain the water-proof.
 - It is possible to extend cable with over 0.3mm² and max. 200m.
 - If the target is plated, the operating distance can be changed by the plating material.
 - It may result in malfunction by metal particle on product.
 - If there are machines(DC type bulb etc), which occurs big surge around this unit, please install the Varistor or absorber to source of surge, even though there is built-in surge absorber in this unit.
 - If connect the load with big inrush current(DC type bulb) to this unit, the big inrush current will flow due to the initial resistance is low. If the current flows, the resistance of load will be bigger, then it will return to standard current. In this case, proximity sensor might be damaged by inrush current. If you use DC type bulb, please connect extra relay or resistance in order to protect proximity sensor from.
 - If make a transceiver close to proximity sensor or wire connection, it may cause malfunction.
- ※ It may cause malfunction if above instructions are not followed.**

Main products

- COUNTER
- TIMER
- TEMPERATURE CONTROLLER
- PANEL METER
- TACHOMETER/LINE SPEED METER/PULSE METER
- DISPLAY UNIT
- PROXIMITY SENSOR
- PHOTOELECTRIC SENSOR
- FIBER OPTIC SENSOR
- PRESSURE SENSOR
- ROTARY ENCODER
- SENSOR CONTROLLER
- POWER CONTROLLER
- STEPPING MOTOR & DRIVER & CONTROLLER

Autonics Corporation
<http://www.autonics.net>

■ HEAD QUARTER :
 41-5, Yongdang-ri, Ungsang-eup, Yangsan-si, Gyeongnam, Korea 626-847

■ INTERNATIONAL SALES :
 512 Ansung B/D, 410-13, Shindorim-dong, Guro-gu, Seoul, Korea 152-070
 TEL:82-2-2679-6585 / FAX:82-2-2679-6556

■ E-mail : sales@autonics.net

NO20030115-EP-KE-07-0120A