

Σ -II SERIES SGM□H/SGDM

USER'S MANUAL

Servo Selection and Data Sheets

SGMAH/SGMPH/SGMGH/SGMSH/SGMDH Servomotors
SGDM Servopack

efesotomasyon.com

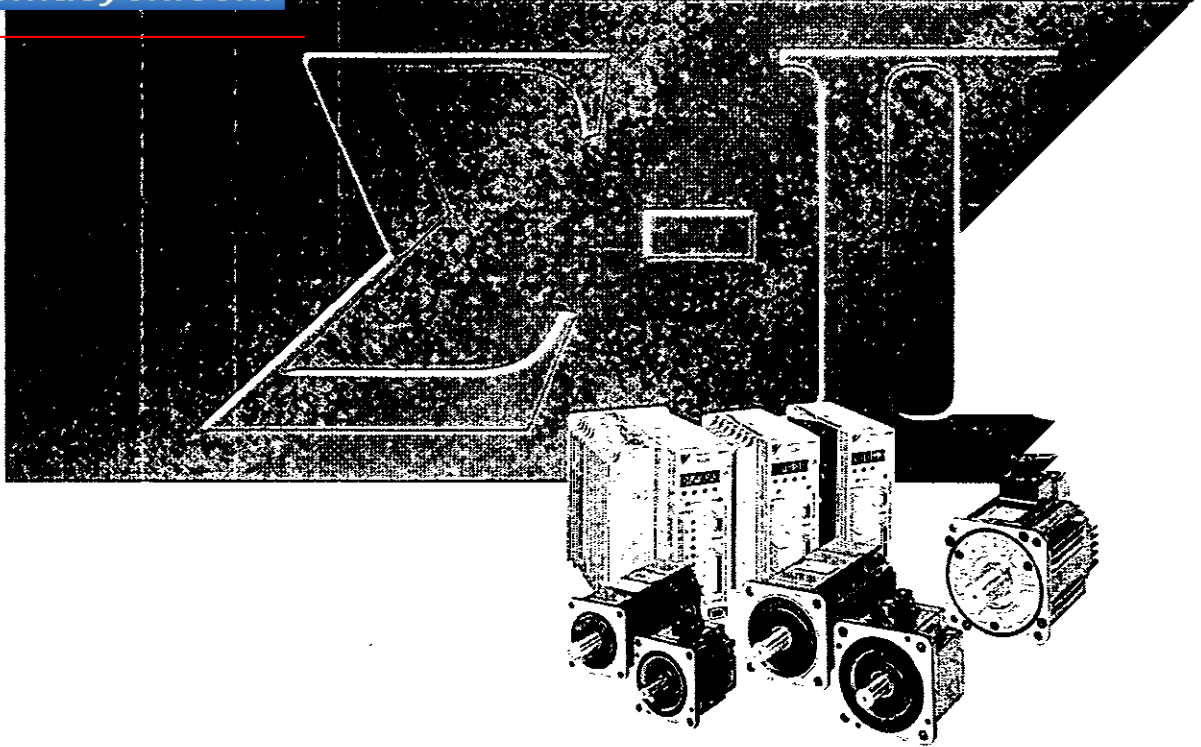

YASKAWA

efesotomasyon.com

MANUAL NO SIE-S800-31 1D

Safety Information

The following conventions are used to indicate precautions in this manual. Failure to heed precautions provided in this manual can result in serious or possibly even fatal injury or damage to the products or to related equipment and systems.

 **WARNING** Indicates precautions that, if not heeded, could possibly result in loss of life or serious injury.

 **CAUTION** Indicates precautions that, if not heeded, could result in relatively serious or minor injury, damage to the product, or faulty operation.

efesotomasyon.com

©Yaskawa, 1998

All rights reserved. No part of this publication may be reproduced, stored in a retrieval system, or transmitted, in any form, or by any means, mechanical, electronic, photocopying, recording, or otherwise, without the prior written permission of Yaskawa. No patent liability is assumed with respect to the use of the information contained herein. Moreover, because Yaskawa is constantly striving to improve its high-quality products, the information contained in this manual is subject to change without notice. Every precaution has been taken in the preparation of this manual. Nevertheless, Yaskawa assumes no responsibility for errors or omissions. Neither is any liability assumed for damages resulting from the use of the information contained in this publication.

Visual Aids

The following aids are used to indicate certain types of information for easier reference



Indicates application examples



Indicates supplemental information



Indicates important information that should be memorized, including precautions such as alarm displays to avoid damaging the devices



Indicates definitions of difficult terms or terms that have not been previously explained in this manual

CONTENTS

Safety Information	III
Visual Aids	IV
Overview	VII
Using This Manual	VIII
1 Selecting Servodrives and Peripheral Devices	
1.1 Selecting Servomotors	1 -2
1 1 1 Model Numbers	1 -2
1 1 2 Servomotor Selection Flowchart	1 -6
1.2 Selecting Servopacks	1 -11
1 2 1 Model Numbers	1 -11
1 2 2 Servopacks and Applicable Servomotors	1 -12
1.3 Selecting Peripheral Devices	1 -14
2 Servomotor Ratings and Specifications	
2.1 Ratings and Specifications	2 -2
2 1 1 SGMAH Servomotors	2 -2
2 1 2 SGMPH Servomotors	2 -16
2 1 3 SGMGH Servomotors for 1500 r/min	2 -29
2 1 4 SGMGH Servomotors for 1000 r/min	2 -39
2 1 5 SGMSH Servomotors	2 -50
2 1 6 SGMDH Servomotors	2 -55
2.2 Mechanical Characteristics	2 -58
2 2 1 Allowable Radial and Thrust Loads	2 -58
2 2 2 Mechanical Tolerance	2 -60
2 2 3 Direction of Servomotor Rotation	2 -60
2 2 4 Impact Resistance	2 -60
2 2 5 Vibration Resistance	2 -61
2 2 6 Vibration Class	2 -61
3 Servopack Ratings and Characteristics	
3.1 Ratings and Specifications	3 -2
3 1 1 Combined Specifications	3 -2
3 1 2 Ratings and Specifications	3 -7
3.2 Characteristics	3 -14
3 2 1 Overload Characteristics	3 -14
3 2 2 Starting and Stopping Time	3 -15
3 2 3 Load Inertia	3 -15
3 2 4 Overhanging Loads	3 -19

4	Servodrive Dimensional Drawings	
4.1	Servomotor Dimensional Drawings	4 -2
4 1 1	SGMAH Servomotors	4 -3
4 1 2	SGMPH Servomotors	4 -25
4 1 3	SGMGH Servomotors (1500 r/min)	4 -42
4 1 4	SGMGH Servomotors (1000 r/min)	4 -62
4 1 5	SGMSH Servomotors	4 -82
4 1 6	SGMDH Servomotors	4 -91
4.2	Servopack Dimensional Drawings	4 -97
4 2 1	Base-mounted Servopacks	4 -98
4 2 2	Rack-mounted Servopacks	4 -106
4 2 3	Duct-ventilated Servopacks	4 -112
5	Specifications and Dimensional Drawings for Peripheral Devices	
5.1	Cable Specifications and Peripheral Devices	5 -2
5 1 1	Cable Specifications	5 -2
5 1 2	Peripheral Device Types and Capacities	5 -6
5.2	Special Options	5 -9
5 2 1	Digital Operator	5 -9
5 2 2	Cables	5 -11
5 2 3	Connectors	5 -18
5 2 4	External Regenerative Resistors	5 -37
5 2 5	Regenerative Resistor Unit	5 -39
5 2 6	DC Reactors for Power Supplies Designed for Minimum Harmonics	5 -41
5 2 7	Brake Power Supplies	5 -42
5 2 8	Absolute Encoder Battery	5 -44
5 2 9	Connector Terminal Block Converter Unit	5 -45
5 2 10	Encoder Signal Converter Unit	5 -47
5 2 11	Cables for Connecting PCs to a Servopack	5 -48
5 2 12	Personal Computer Monitoring Software	5 -52
5.3	Peripheral Devices	5 -53
5 3 1	Molded-case Circuit Breaker (MCCB)	5 -53
5 3 2	Noise Filter	5 -53
5 3 3	Magnetic Contactor	5 -55
5 3 4	Surge Suppressor	5 -57
5 3 5	Variable Resistor for Speed Setting	5 -57
INDEX		Index-1

Overview

■ About this Manual

This manual provides the following information for the Σ -II Series SGM□H/SGDM Servodrives

- Selecting Servodrives
- Features and characteristics of the Servodrives
- Specifications and dimensions of peripheral devices

■ Related Manuals

Refer to the following manuals as required

Read this manual carefully to ensure the proper use of Σ -II Series Servodrives. Also, keep this manual in a safe place so that it can be referred to whenever necessary.

Manual Name	Manual Number	Contents
Σ -II Series SGM□H/SGDM User's Manual Design and Maintenance	SIE-S800-31 2	Provides detailed information on the installation, wiring, trial operation, functions, maintenance, and inspection of Σ -II Series Servodrives
Σ -II Series SGM□H/SGDM Computer Monitoring Software User's Manual	SIE-S800-35	Describes the applications and operation of software for the Σ -II Series Servodrive monitoring devices for use on personal computers
Σ -II Series SGM□H/SGDM Digital Operator Operation Manual	TO-S800-34	Provides detailed information on the operation of the JUSP-OP02A-2 Digital Operator, which is an optional product

Using This Manual

■ Intended Audience

This manual is intended for the following users

- Those selecting Σ -II Series Servodrives
- Those selecting peripheral devices for Σ -II Series Servodrives
- Those wanting to know about the ratings and characteristics of Σ -II Series Servodrives

■ Description of Technical Terms

In this manual, the following terms are defined as follows

- **Servomotor** = Σ -II Series SGMAH/SGMPH/SGMGH/SGMSH/SGMDH Servomotor
- **Servopack** = Σ -II Series SGDM Servopack
- **Servodrive** = A set including a Servomotor and Servo Amplifier
- **Servo System** = A servo control system that includes the combination of a Servodrive with a host computer and peripheral devices

■ Indication of Reverse Signals

In this manual, the names of reverse signals (ones that are valid when low) are written with a forward slash (/) before the signal name, as shown in the following example

- $\overline{S-ON}$ = /S-ON
- $\overline{P-CON}$ = /P-CON

1

Selecting Servodrives and Peripheral Devices

This chapter describes the procedure used to select Servomotors, Servopacks, and peripheral devices

1.1	Selecting Servomotors	2
1 1 1	Model Numbers	2
1 1 2	Servomotor Selection Flowchart	6
1.2	Selecting Servopacks	11
1 2 1	Model Numbers	11
1 2 2	Servopacks and Applicable Servomotors	12
1.3	Selecting Peripheral Devices	14

1.1 Selecting Servomotors

This section describes the available models and provides flowcharts for selecting Servomotors

The models are selected according to whether the Servomotor has gears or not The standard model has no gears

The numbers 1) through 8) in *Model Numbers for Standard Servomotors* and *Model Numbers for Servomotors with Gears* below correspond to the numbers in the flowchart for Servomotor selection on the following pages

1.1.1 Model Numbers

A Servomotor can be selected based on the alphanumeric characters after SGM□H

■ Model Numbers for Standard Servomotors

SGMPH – 01 A A A 2 S

Σ-II Series Servomotor Name

- SGMAH
- SGMPH
- SGMGH
- SGMSH
- SGMDH

1) Servomotor Capacity (See Table 1 1)

2) Supply Voltage

- A 200 V
- B 100 V*

* The only 100-V Servomotors are the 0.2 kW or less SGMAH and SGMPH Servomotors

3) Serial Encoder Specifications (See Table 1 2)

8) Brake and Oil Seal Specifications

- 1 With brake, no oil seal
- S With oil seal
- B With 90 VDC brake
- C With 24 VDC brake
- D S + B
- E S + C

7) Shaft End Specification (See Table 1 3)

4) Design Revision Order

- A SGMAH
- SGMPH
- SGMGH (1500 r/min)
- SGMSH
- SGMDH
- B SGMGH (1000 r/min)
- C SGMGH (1500 r/min) high-precision machine tools
- D SGMGH (1000 r/min) high-precision machine tools
- E SGMPH (IP67 waterproof specification)

Table 1.1 Servomotor Capacity (kW)

Code	SGMAH	SGMPH	SGMGH		SGMSH	SGMDH	Code	SGMAH	SGMPH	SGMGH		SGMSH	SGMDH
	3000 r/min	3000 r/min	1500 r/min	1000 r/min	3000 r/min	2000 r/min		3000 r/min	3000 r/min	1500 r/min	1000 r/min	3000 r/min	2000 r/min
A3	0.03						15		1.5			1.5	
A5	0.05						20			1.8	2.0	2.0	
01	0.1	0.1					22						2.2
02	0.2	0.2					30			2.9	3.0	3.0	
03				0.3			32						3.2
04	0.4	0.4					40				4.0	4.0	4.0
05			0.45				44			4.4			
06				0.6			50					5.0	
08	0.75	0.75					55			5.5	5.5		
09			0.85	0.9			75			7.5			
10					1.0		1A			11			
12				1.2			1E			15			
13			1.3				-						

Table 1.2 Serial Encoders

Code	Specification	SGMAH	SGMPH	SGMGH	SGMSH	SGMDH
1	16-bit absolute encoder	Standard	Standard			
2	17-bit absolute encoder			Standard	Standard	Standard
A	13-bit incremental encoder	Standard	Standard			
B	16-bit incremental encoder	Optional	Optional			
C	17-bit incremental encoder			Standard	Standard	Standard

Table 1 3 Shaft End Specifications

Code	Specification	SGMAH	SGMPH	SGMGH	SGMSH	SGMDH
2	Straight without key	Standard	Standard	Standard	Standard	Standard
3	Taper 1/10, with parallel key			Optional	Optional	
4	Straight, with key	Optional	Optional			
5	Taper 1/10, with woodruff key			Optional		
6	Straight, with key and tap	Optional	Optional	Optional	Optional	Optional
8	Straight, with tap	Optional	Optional			

efesotomasyon.com

■ Model Numbers for Servomotors with Gears

SGMPH – 01 A A A G 1 2 B

Σ-II Series Servomotor Name

- SGMAH
- SGMPH
- SGVGH
- SGMSH

1) Servomotor Capacity (See Table 1 4)

2) Supply Voltage

- A 200 V
- B 100 V*

* The only 100-V Servomotors are the 0.2 kW or less SGMAH and SGMPH Servomotors

3) Serial Encoder Specifications (See Table 1 5)

4) Design Revision Order

- A SGMAH
- SGMPH
- SGMGH (1500 r/min)
- SGMSH
- B SGMGH (1000 r/min)
- E SGMPH (IP67 waterproof specification)

8) Brake Specifications

- 1 Without brake
- B With 90 VDC brake
- C With 24 VDC brake

7) Shaft End Specification (See Table 1 8)

(Varies with gear type)

6) Gear Ratio (See Table 1 7)

(Varies with gear type)

5) Gear Type (See Table 1 6)

Table 1.4 Servomotor Capacity (kW)

Code	SGMAH	SGMPH	SGMGH		SGMSH	Code	SGMAH	SGMPH	SGMGH		SGMSH
	3000 r/min	3000 r/min	1500 r/min	1000 r/min	3000 r/min		3000 r/min	3000 r/min	1500 r/min	1000 r/min	3000 r/min
A3	0.03					15		1.5			1.5
A5	0.05					20			1.8	2.0	2.0
01	0.1	0.1				22					
02	0.2	0.2				30			2.9	3.0	3.0
03				0.3		32					
04	0.4	0.4				40				4.0	4.0
05			0.45			44			4.4		
06				0.6		50					5.0
08	0.75	0.75				55			5.5	5.5	
09			0.85	0.9		75			7.5		
10					1.0	1A			11		
12				1.2		1E			15		
13			1.3			-					

Table 1.5 Serial Encoders

Code	Specification	SGMAH	SGMPH	SGMGH	SGMSH
1	16-bit absolute encoder	Standard	Standard		
2	17-bit absolute encoder			Standard	Standard
A	13-bit incremental encoder	Standard	Standard		
B	16-bit incremental encoder	Optional	Optional		
C	17-bit incremental encoder			Standard	Standard

Table 1.6 Gear Type

Code	Specification	SGMAH	SGMPH	SGMGH	SGMSH
G	HDS planetary low-backlash gear	Standard	Standard		
J	Standard backlash gear	Standard	Standard		
S	With foot			Standard	
T	Flange			Standard	
L	IMT planetary low-backlash gear			Standard	Standard

Table 1.7 Gear Ratio (Varies with Gear Type)

Code	Specification	SGMAH	SGMPH	SGMGH	SGMSH
A	1/6			S, T*	
B	1/11 or 1/11 13	G*	G, J*	S, T	
C	1/21	G, J	G, J	S, T	
1	1/5	G, J	G, J	L	L
2	1/9	G*		L	L
3	1/10 or 1/10 3	J	J		
5	1/20			L*	L
7	1/29 or 1/33	G, J	G, J	L, S, T*	L*
8	1/45			L*	L*

* Not all applicable models available

Table 1.8 Shaft End Specification (Varies with Gear Type)

Code	Specification	SGMAH	SGMPH	SGMGH	SGMSH
0	No shaft	G	G		
2	Straight, without key	G, J	G, J		
4	Straight, with key	G	G	L	L
6	Straight, with key and tap	G, J	G, J	S, T	
8	Straight, with tap	G	G		

1.1.2 Servomotor Selection Flowchart

Use the following flowchart to select SGMAH, SGMPH, SGMGH, SGMSH or SGMDH Servomotors

■ Selection Flowchart

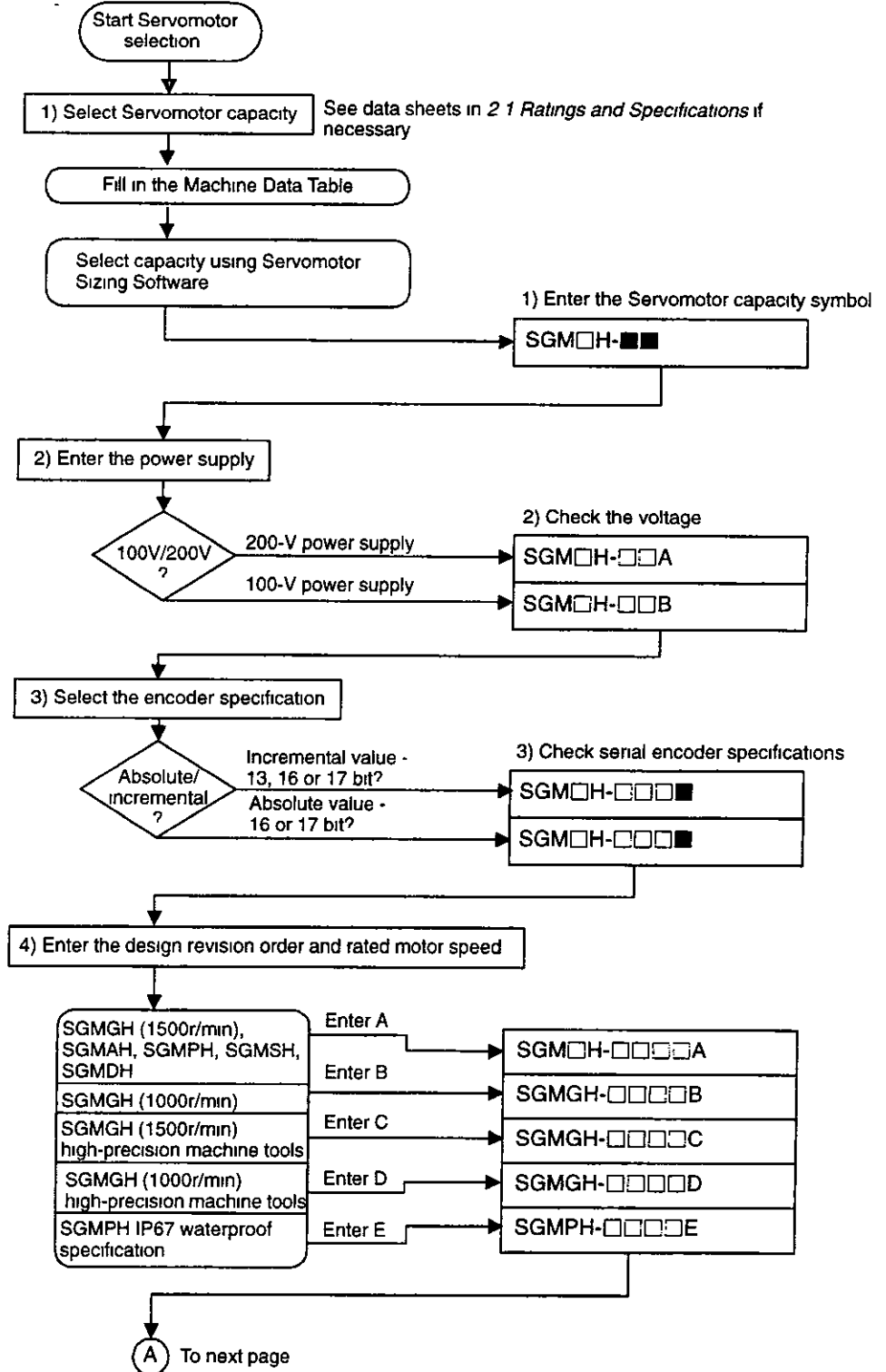

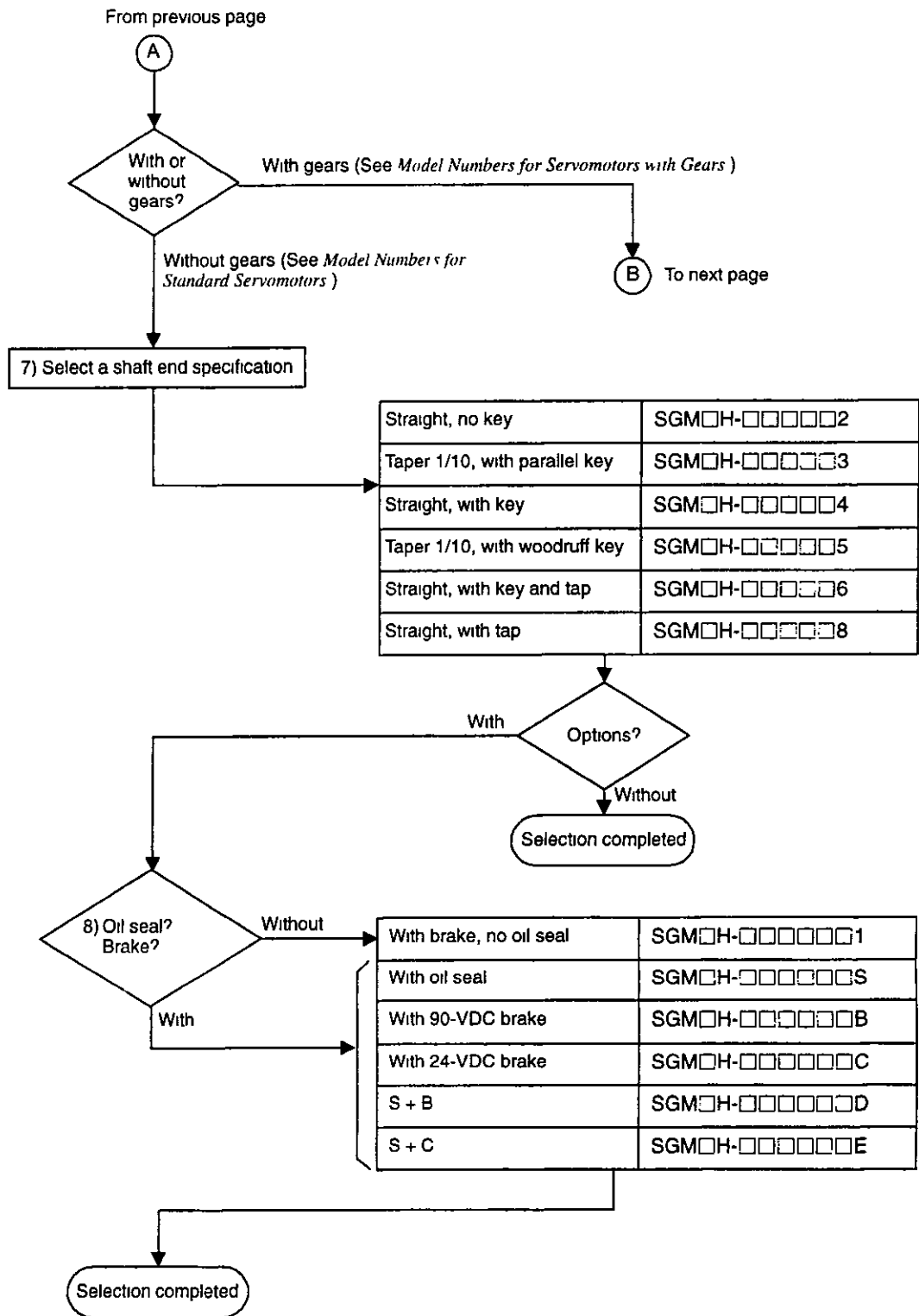

* Servomotor Sizing Software is available free of charge. Consult your Yaskawa representative.

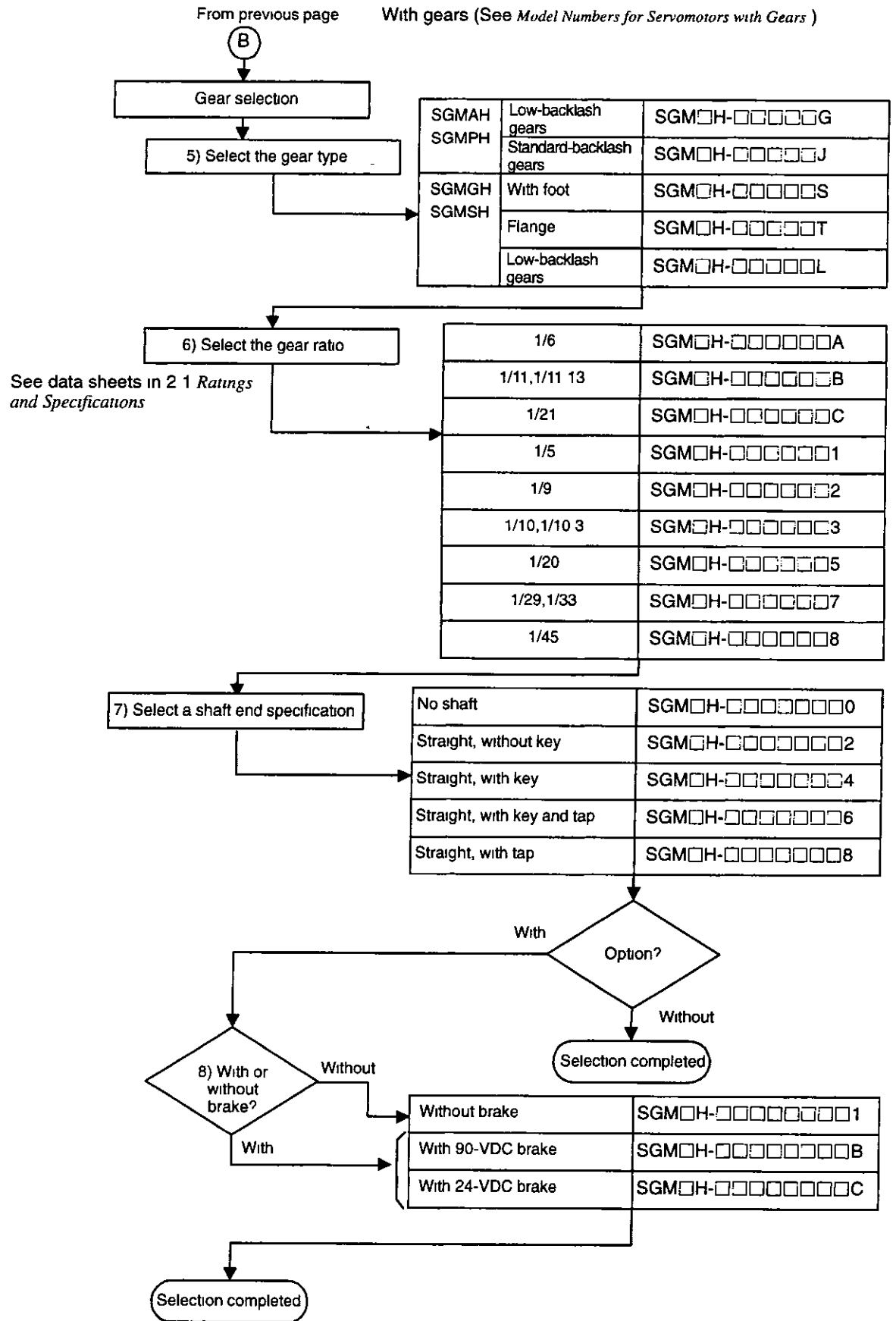

■ Selecting Capacity Based on Machine Specifications

Fill out the data table below as an aid in selecting a drive system. When the machine data table is complete, use the Servomotor Sizing Software to select motor capacity.

Table 1.9 Machine Data Table

Ball Screw Horizontal Axis			Device Configuration
Load mass *1	W	kg	
Thrust	F	N	
Friction coefficient	μ		
Overall efficiency	η		
Gear ratio *2	$R (=Nm/N)$		
Gear + coupling *3	Jg	kg cm ²	
Ball screw pitch	P	mm	
Ball screw diameter	D	mm	
Ball screw length	L	mm	
Ball Screw Vertical Axis			
Load mass	W1	kg	
Counterweight	W2	kg	
Friction coefficient	μ		
Overall efficiency	η		
Gear ratio	$R (=Nm/N)$		
Gear + coupling	Jg	kg cm ²	
Ball screw pitch	P	mm	
Ball screw diameter	D	mm	
Ball screw length	L	mm	
Timing Belt			
Load mass	W	kg	
Thrust	F	N	
Friction coefficient	μ		
Overall efficiency	η		
Gear ratio	$R (=Nm/N)$		
Gear + coupling	Jg	kg cm ²	
Pulley moment of inertia	Jp	kg cm ²	
Pulley diameter	D	mm	
Rack and Pinion			
Load mass	W	kg	
Thrust	F	N	
Friction coefficient	μ		
Overall efficiency	η		
Gear ratio	$R (=Nm/N)$		
Gear + coupling	Jg	kg cm ²	
Pinion diameter	D	mm	
Pinion thickness	t	mm	

Selecting Servodrives and Peripheral Devices

1 1 2 Servomotor Selection Flowchart

Roll Feeder			
Load moment of inertia	J_w	kg cm^2	
Tension	F	N	
Press force	P	N	
Roller diameter	D	mm	
Friction coefficient	μ		
Overall efficiency	η		
Gear ratio	$R (=Nm/N)$		
Gear + coupling	J_g	kg cm^2	
Rotor			
Load moment of inertia	J_I	kg cm^2	
Load torque	T_I	kg cm	
Overall efficiency	η		
Gear ratio	$R (=Nm/N)$		
Gear + coupling	J_g	kg cm^2	
Others			
Load moment of inertia	J_I	kg cm^2	
Load torque	T_I	N m	
Motor speed	N_m	r/min	
Duty	t_c	s	
Positioning time	t_s	s	
Accel/decel time	t_a	s	
Duty Cycle			
Duty	t_c	s	
Positioning distance	L_s	mm	
Slide speed	V_I	m/min	
Positioning time	t_s	s	
Accel/decel time	t_a	s	
Enter either V_I or t_s . Specify the priority if both are entered			
Operating environment			
Ambient temperature			
Others			

- * 1 Moment of inertia J for table W (load mass) can be calculated with the Sizing Software. Moment of inertia J for the Servomotor is calculated automatically with the Sizing Software.
- * 2 Gear ratio $R = N_m/N = \text{Motor speed/load-end speed}$
- * 3 Gear + coupling J_g . Gear or coupling moment of inertia
This is the moment of inertia for coupling between the Servomotor and the load (machine).

1.2 Selecting Servopacks

The following section describes Servopack models and applicable Servomotors

1.2.1 Model Numbers

The Servopack for the applicable servo system is selected based on the four alphanumeric characters (capacity and power supply) after SGDM. Refer to *Table 1 11* on the next page

Model Numbers

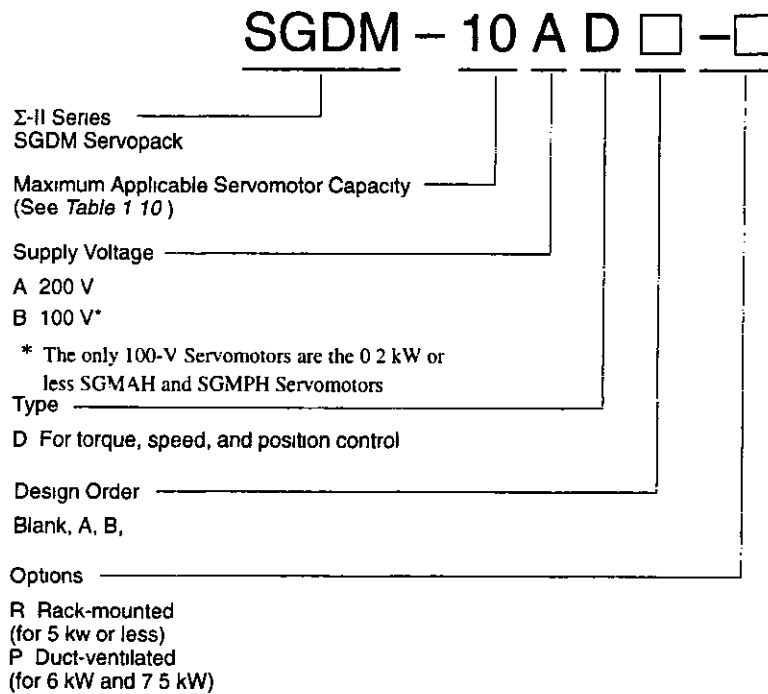

Table 1.10 Servomotor Capacity (kW)

Maximum Applicable Servomotor Capacity Code	Capacity (kW)	Maximum Applicable Servomotor Capacity Code	Capacity (kW)
A3	0.03	15	1.5
A5	0.05	20	2.0
01	0.10	30	3.0
02	0.20	50	5.0
04	0.40	60	6.0
05	0.50	75	7.5
08	0.75	1A	11
10	1.0	1E	15

1.2.2 Servopacks and Applicable Servomotors

The Servopack model selected depends on the Servomotor that is used. Use the following table to select Servopacks.

Table 1.11 Servopacks and Applicable Servomotors

Main Circuit Power Supply	Capacity (kW)	Servopack Model	Applicable Servomotor
Single-phase 200V	0.03	SGDM-A3AD	SGMAH-A3A
		SGDM-A3ADA	
	0.05	SGDM-A5AD	SGMAH-A5A
		SGDM-A5ADA	
	0.10	SGDM-01AD	SGMAH-01A
		SGDM-01ADA	SGMPH-01A
	0.20	SGDM-02AD	SGMAH-02A
		SGDM-02ADA	SGMPH-02A
	0.40	SGDM-04AD	SGMAH-04A
		SGDM-04ADA	SGMPH-04A

Main Circuit Power Supply	Capacity (kW)	Servopack Model	Applicable Servomotor
Three-phase 200V	0.50	SGDM-05AD	SGMGH-05A□A
		SGDM-05ADA	SGMGH-03A□B
	0.75	SGDM-08AD SGDM-08ADA	SGMAH-08A
			SGMPH-08A
			SGMGH-06A□B
	1.0	SGDM-10AD SGDM-10ADA	SGMGH-09A□A
			SGMGH-09A□B
			SGMSH-10A
	1.5	SGDM-15AD SGDM-15ADA	SGMPH-15A
			SGMGH-13A□A
			SGMGH-12A□B
			SGMSH-15A
	2.0	SGDM-20AD SGDM-20ADA	SGMGH-20A□A
			SGMGH-20A□B
			SGMSH-20A
	3.0	SGDM-30AD SGDM-30ADA	SGMDH-22A
			SGMGH-30A□A
			SGMGH-30A□B
SGMSH-30A			
5.0	SGDM-50ADA	SGMDH-32A	
		SGMDH-40A	
		SGMSH-40A	
		SGMGH-44A□A	
		SGMGH-40A□B	
		SGMSH-50A	
6.0	SGDM-60ADA	SGMGH-55A□A	
		SGMGH-55A□B	
7.5	SGDM-75ADA	SGMGH-75A□A	
11	SGDM-1AADA	SGMGH-1AA□A	
15	SGDM-1EADA	SGMGH-1EA□A	
Single-phase 100V	0.03	SGDM-A3BD	SGMAH-A3B
		SGDM-A3BDA	
	0.05	SGDM-A5BD	SGMAH-A5B
		SGDM-A5BDA	
0.10	SGDM-01BD SGDM-01BDA	SGMAH-01B	
		SGMPH-01B	
0.20	SGDM-02BD SGDM-02BDA	SGMAH-02B	
		SGMPH-02B	

1.3 Selecting Peripheral Devices

Select peripheral devices using the flowcharts on the following pages as guides

See chapter 5 *Specifications and Dimensional Drawings for Peripheral Devices* for more details on items not included in the flowcharts

Flowchart for Selecting Peripheral Devices

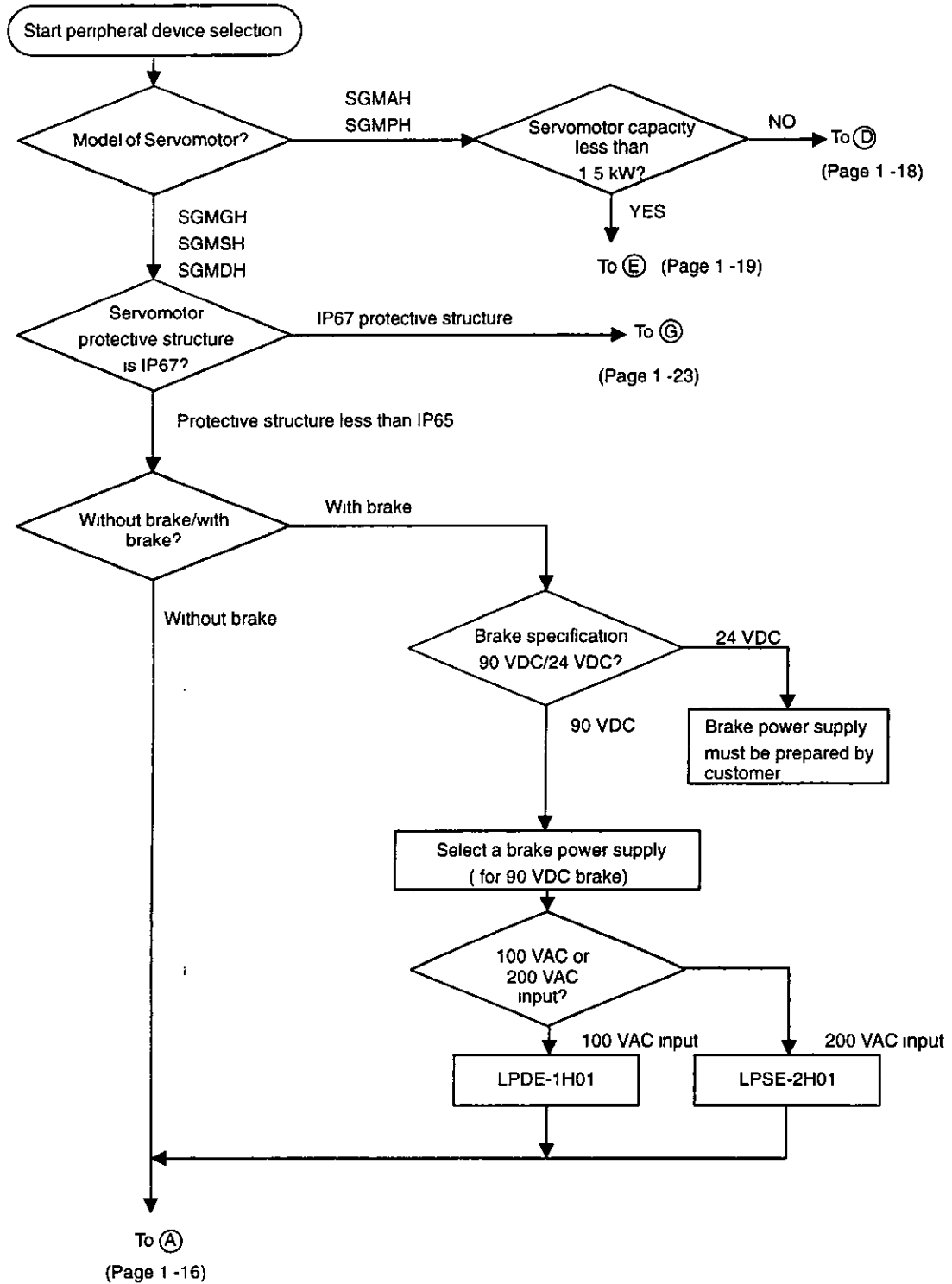

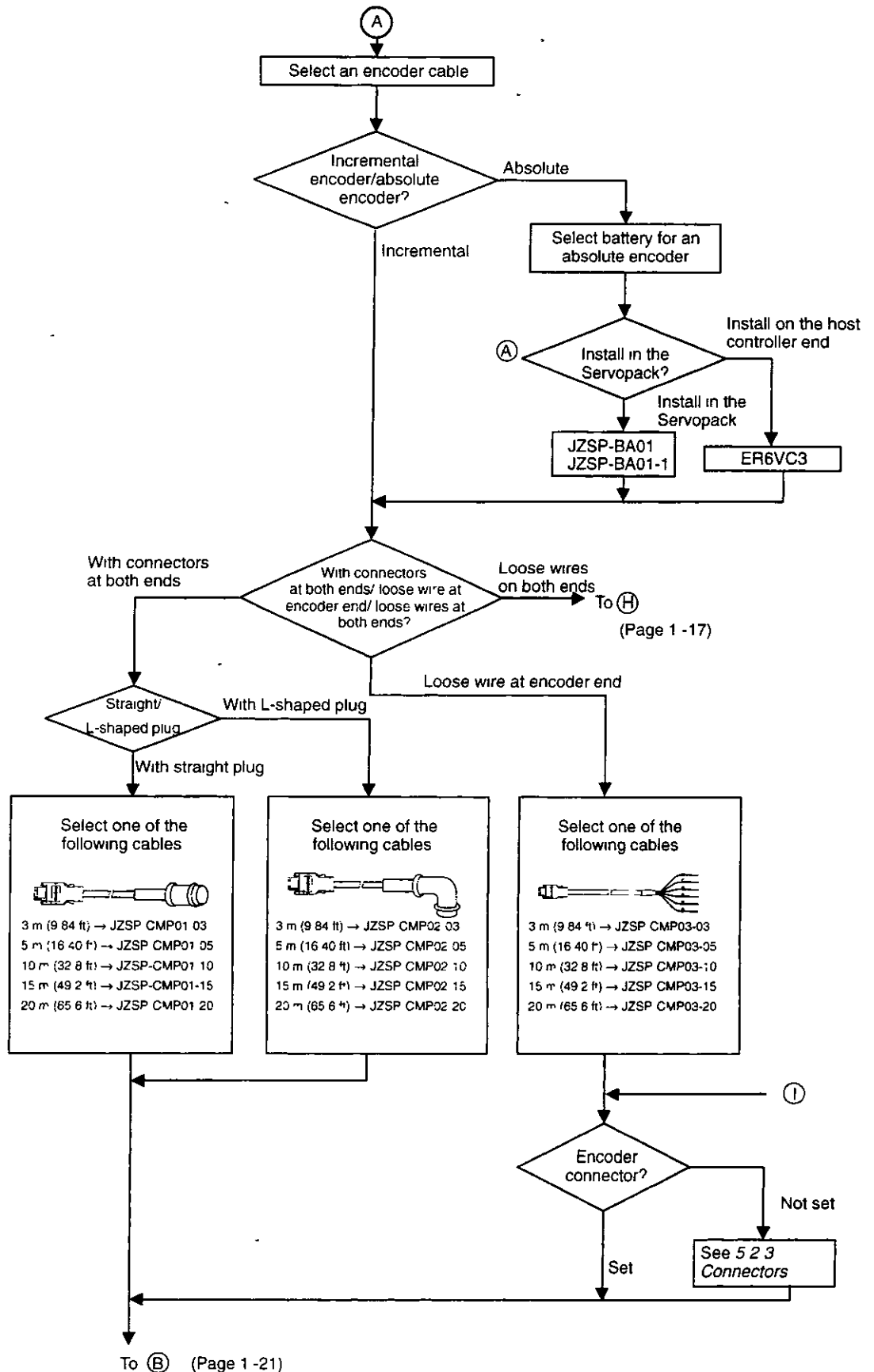

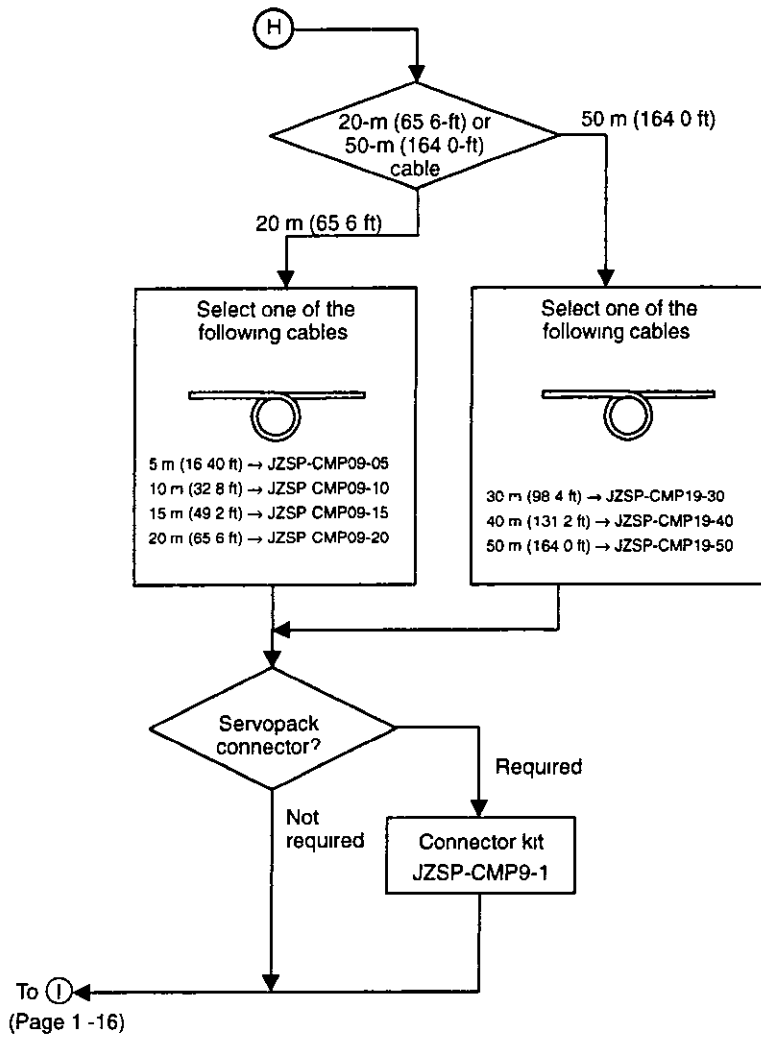

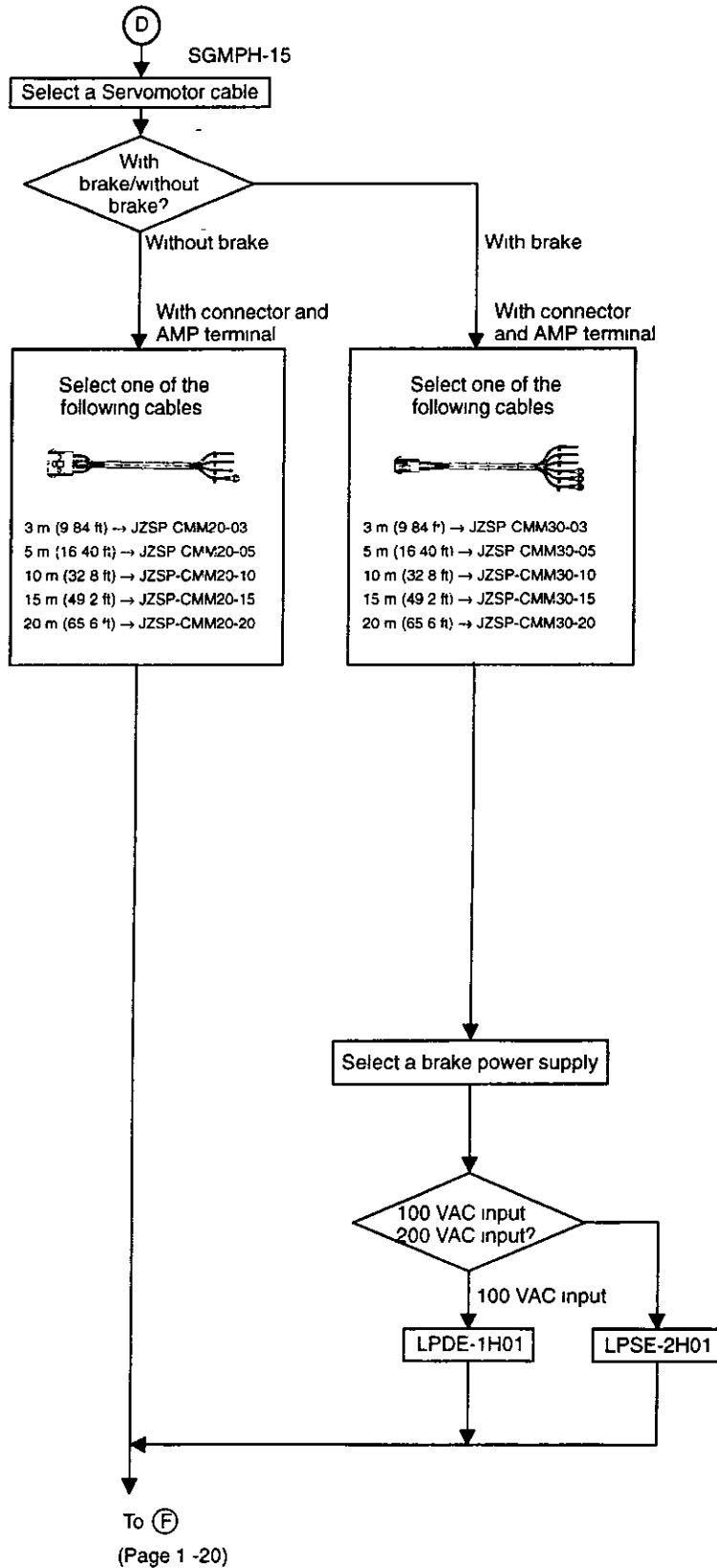

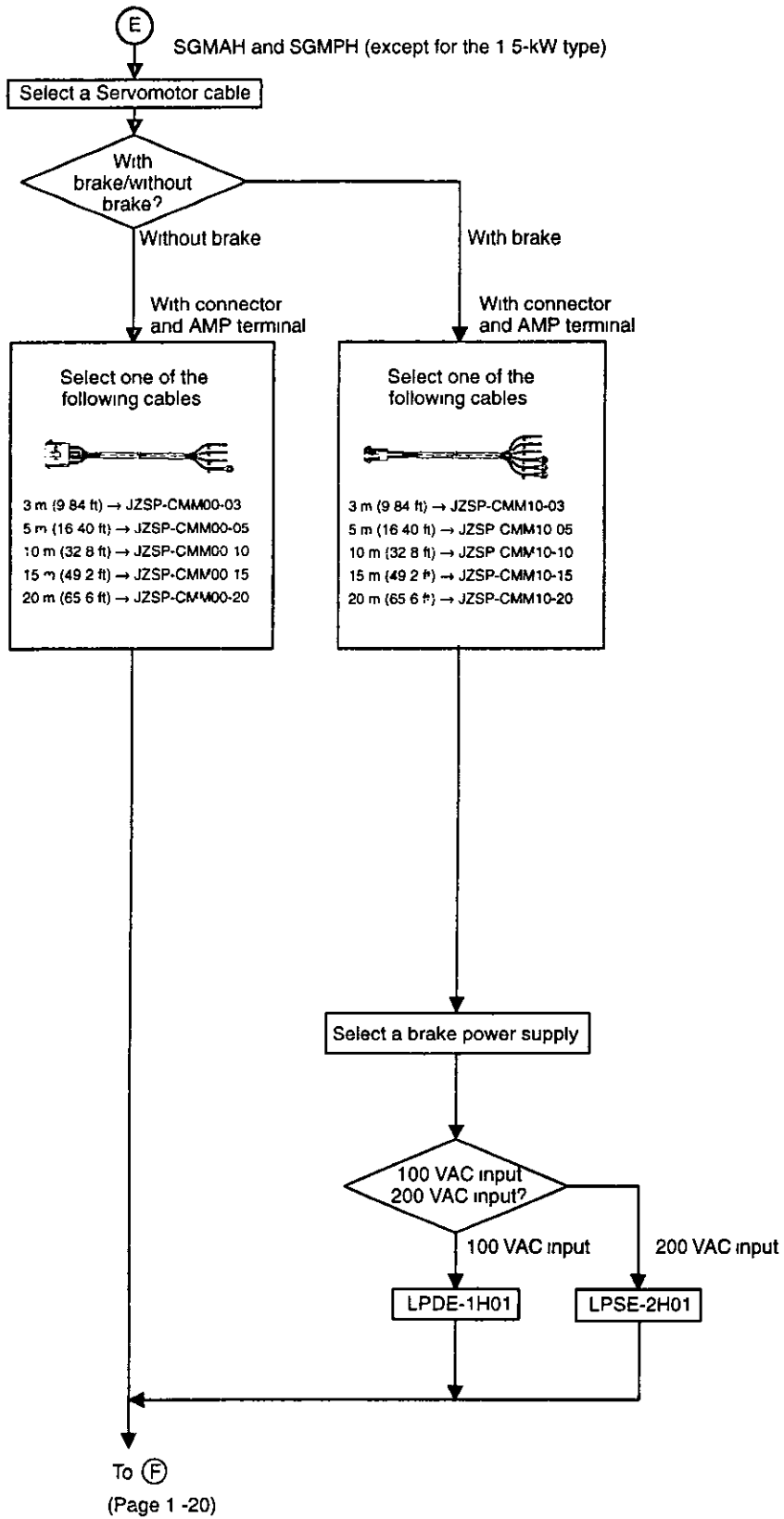

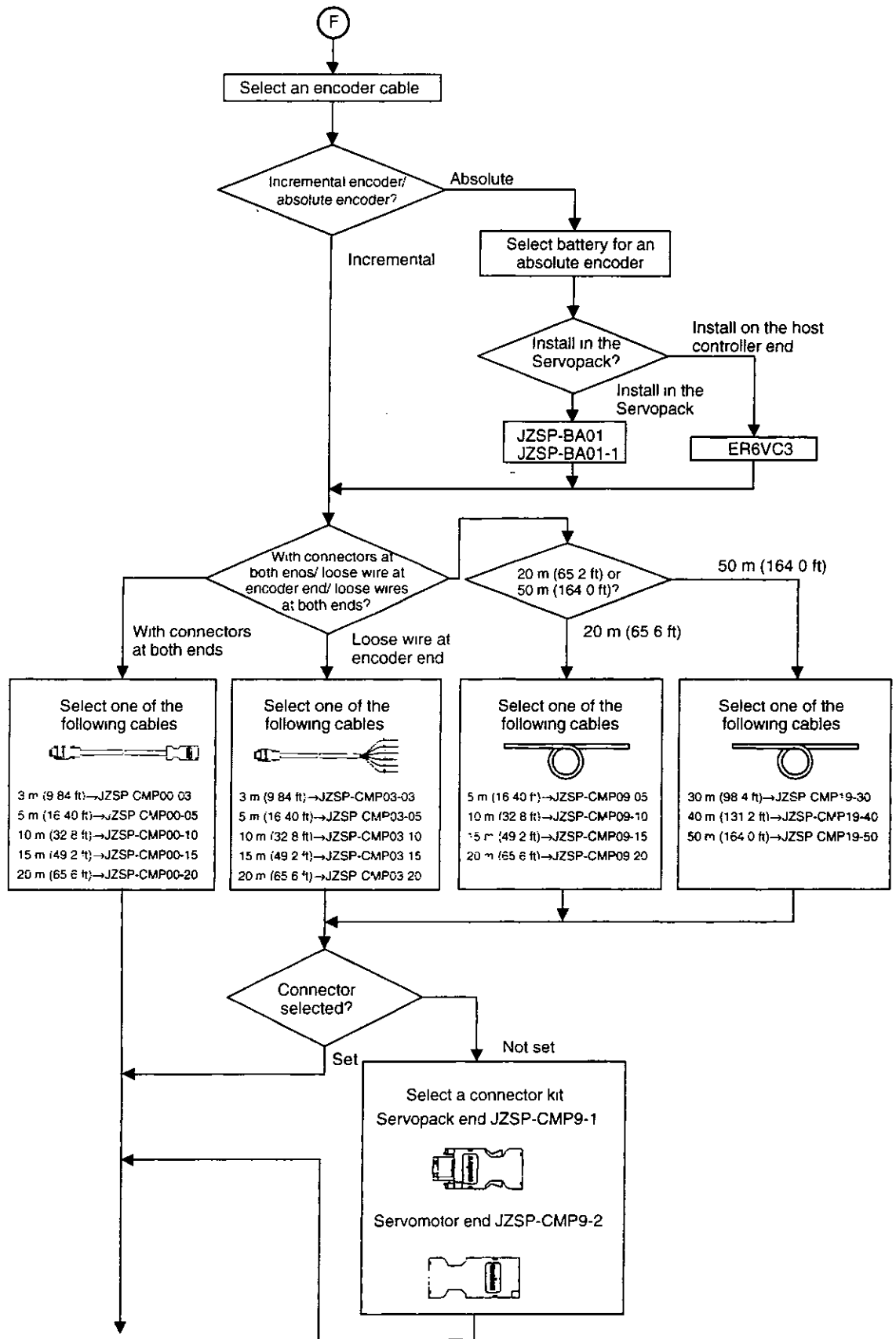

To (B) (Page 1 -21)

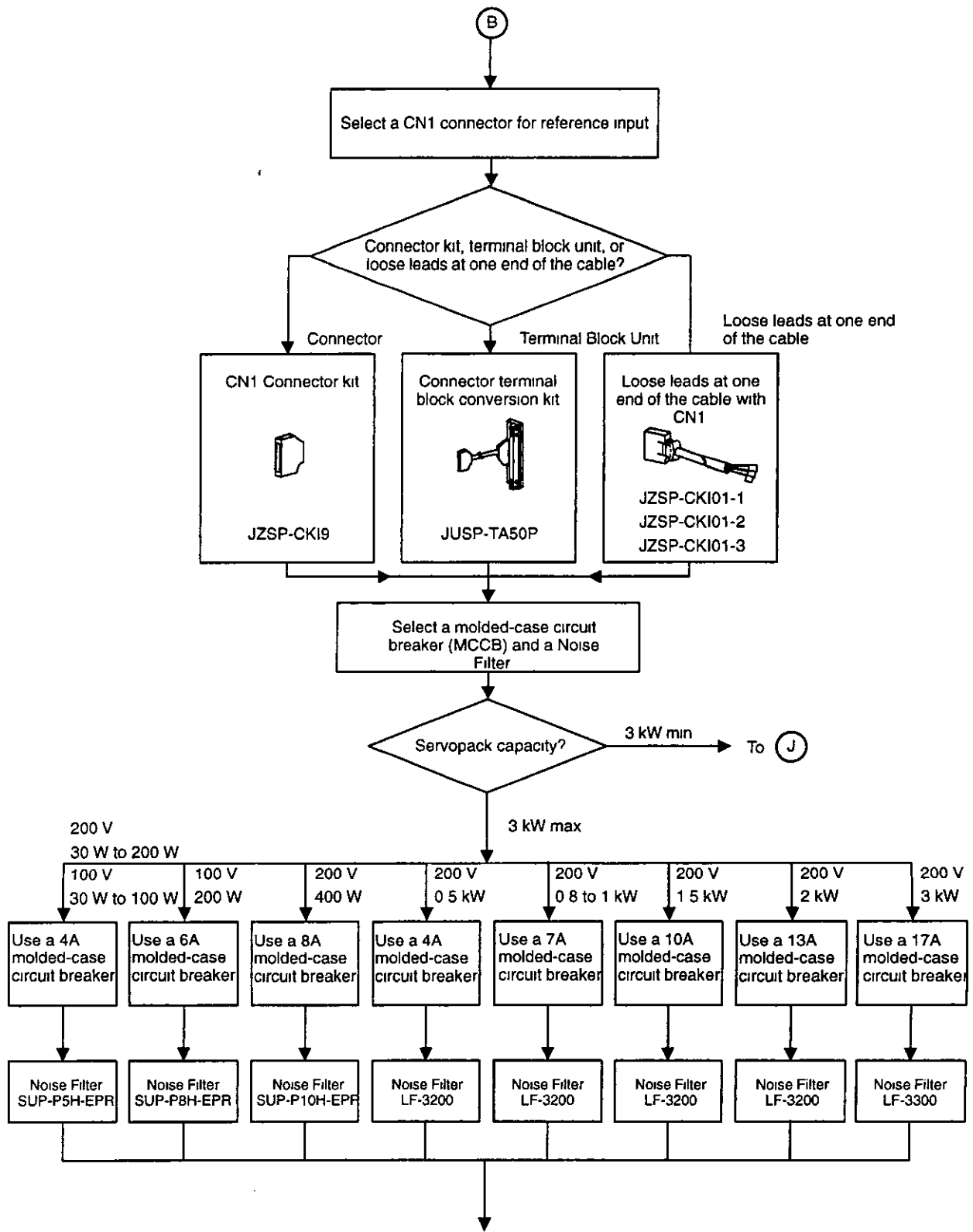

To ©
(Page 1 -22)

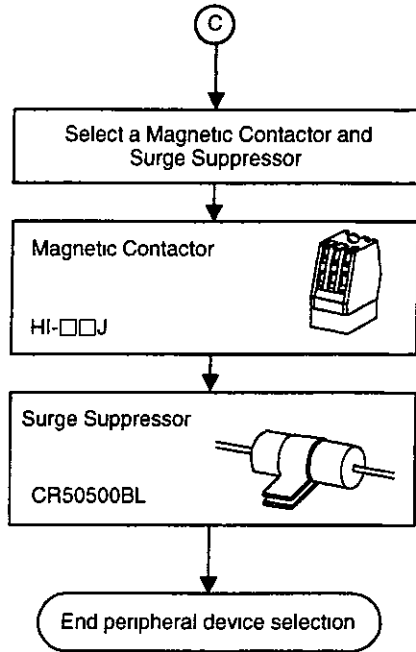
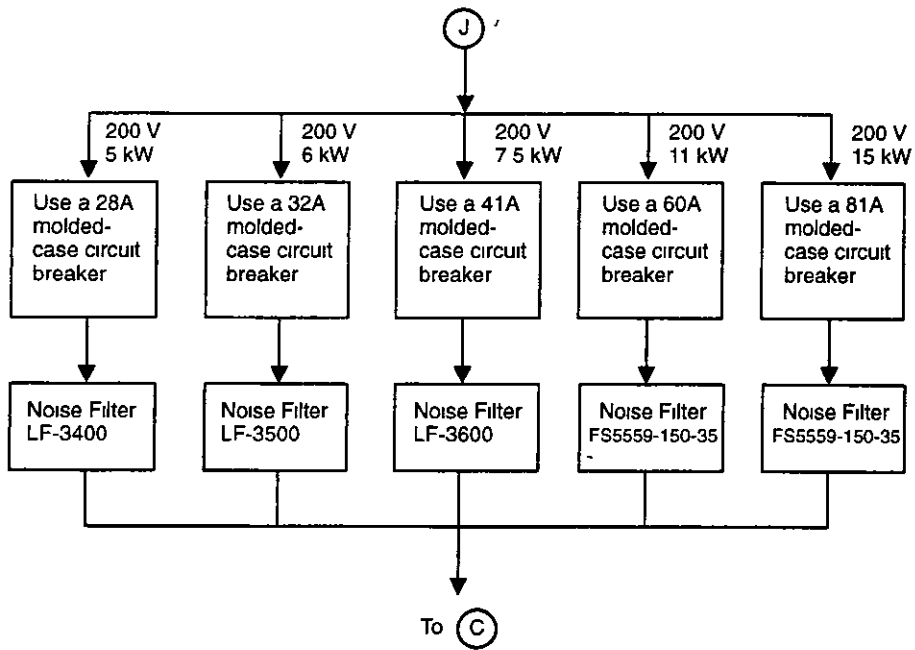

- See 5.1.1 Cable Specifications to set this. For multiple servo systems, select a Magnetic Contactor based on total current capacity.

- This is the Surge Suppressor for HI-□□J shown above.

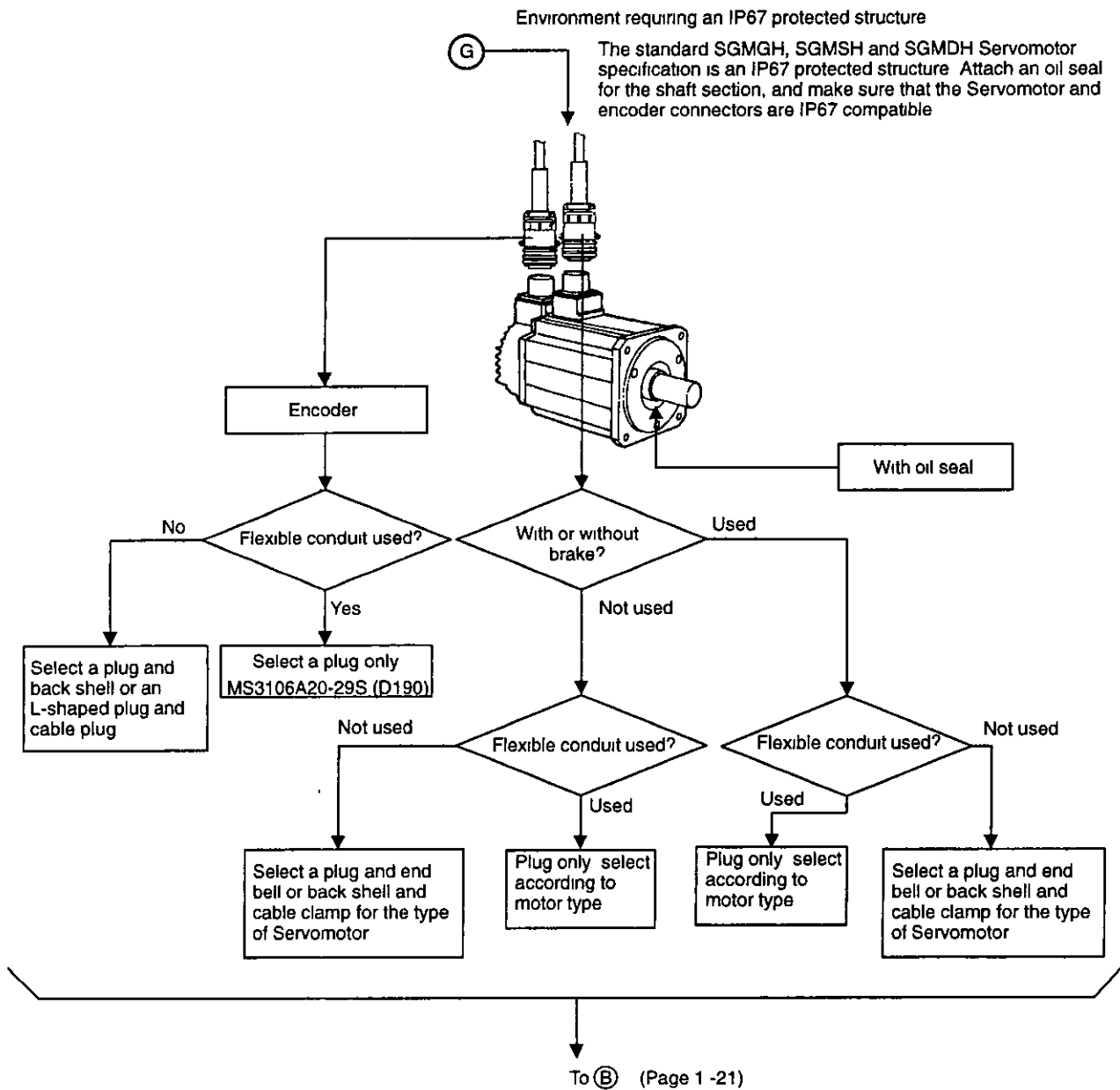

- Note 1** Customers must provide the power cable and flexible conduit
- 2 Customers must provide the cable as well as the Servopack-end and encoder-end connector kits, and must then assemble the encoder cable
 3. Select a brake power supply unit and batteries for the absolute encoder before moving on to Flowchart (B)

2

Servomotor Ratings and Specifications



This chapter provides the ratings, specifications, and mechanical characteristics of the Servomotors

2 1	Ratings and Specifications	2 - 2
2 1 1	SGMAH Servomotors	2 - 2
2 1 2	SGMPH Servomotors	2 - 16
2 1 3	SGMGH Servomotors for 1500 r/min	2 - 29
2 1 4	SGMGH Servomotors for 1000 r/min	2 - 39
2 1 5	SGMSH Servomotors	2 - 50
2 1 6	SGMDH Servomotors	2 - 55
2 2	Mechanical Characteristics	2 - 58
2 2 1	Allowable Radial and Thrust Loads	2 - 58
2 2 2	Mechanical Tolerance	2 - 60
2 2 3	Direction of Servomotor Rotation	2 - 60
2 2 4	Impact Resistance	2 - 60
2 2 5	Vibration Resistance	2 - 61
2 2 6	Vibration Class	2 - 61

2.1 Ratings and Specifications

The following sections provide the ratings and specifications of the Servomotors by model

2.1.1 SGMAH Servomotors

■ Rating and Specifications for Standard Servomotors Without Gears

- Time Rating Continuous
- Vibration Class 15 μm or below
- Insulation Resistance 500 VDC, 10 M Ω min
- Ambient Temperature 0 to 40°C
- Excitation Permanent magnet
- Mounting Flange method
- Thermal Class B
- Withstand Voltage 1500 VAC for one minute
- Enclosure Totally enclosed, self-cooled, IP55 (except through sections of the shaft)
- Ambient Humidity 20% to 80% (with no condensation)
- Drive Method Direct drive

Table 2.1 SGMAH Standard Servomotor Ratings and Specifications

Voltage		200 V						100 V			
Servomotor Model SGMAH-		A3A	A5A	01A	02A	04A	08A	A3B	A5B	01B	02B
Rated Output *1	kW	0.03	0.05	0.1	0.2	0.4	0.75	0.03	0.05	0.1	0.2
Rated Torque *1,2	N m	0.0955	0.159	0.318	0.637	1.27	2.39	0.0955	0.159	0.318	0.637
	oz-in	13.52	22.5	45.1	90.2	180	338	13.52	22.5	45.1	90.2
Instantaneous Peak Torque *1	N m	0.286	0.477	0.955	1.91	3.82	7.16	0.286	0.477	0.955	1.91
	oz-in	40.6	67.6	135.2	270	541	1010	40.6	67.6	135.2	270
Rated Current *1	A (rms)	0.44	0.64	0.91	2.1	2.8	4.4	0.66	0.95	2.4	3.0
Instantaneous Max Current *1	A (rms)	1.3	2.0	2.8	6.5	8.5	13.4	2.0	2.9	7.2	9.0
Rated Speed *1	r/min	3000									
Max. Speed *1	r/min	5000									
Torque Constant	N-m/A (rms)	0.238	0.268	0.378	0.327	0.498	0.590	0.157	0.182	0.146	0.234
	oz in/A (rms)	33.7	38.0	53.6	46.2	70.6	83.6	22.2	25.8	20.7	33.2
Moment of Inertia J	$\times 10^{-4}\text{kg m}^2$	0.0166	0.0220	0.0364	0.106	0.173	0.672	0.0166	0.0220	0.0364	0.106
	$\times 10^{-3}\text{oz in-s}^2$	0.235	0.312	0.515	1.501	2.45	9.52	0.235	0.312	0.515	1.501
Rated Power Rate *1	kW/s	5.49	11.5	27.8	38.2	93.7	84.8	5.49	11.5	27.8	38.2
Rated Angular Acceleration *1	rad/s ²	57500	72300	87400	60100	73600	35500	57500	72300	87400	60100
Moment of Inertia Time Constant	ms	1.4	0.88	0.53	0.39	0.25	0.26	1.4	0.85	0.61	0.41
Inductive Time Constant	ms	1.0	1.1	1.2	4.6	5.4	8.7	1.0	1.1	1.1	4.4

- * 1 These items and torque-motor speed characteristics quoted in combination with an SGDM Servopack are at an armature winding temperature of 100°C. Other values quoted at 20°C. All values are typical.
- * 2 Rated torques are continuous allowable torque values at 40°C with a 250 × 250 × 6 (mm) (10 × 10 × 0.25 (in)) heat sink attached.

Note 1 Add the numerical values given below to the moment of inertia values in the table for Servomotors fitted with a holding brake. Other specifications will also change slightly.

Servomotor Model SGMAH-		A3A A3B	A5A A5B	01A 01B	02A 02B	04A	08A
Holding Brake	$\times 10^{-4}$ kg·m ²	0.0085			0.058		0.14
	$\times 10^{-3}$ oz·in·s ²	0.120			0.821		1.983

2 When a motor is fitted with a shaft seal, use the following reduction ratings because of the higher friction torque. Other specifications will also change slightly.

Servomotor Model SGMAH-	A3A A3B	A5A A5B	01A 01B	02A 02B	04A	08A
Derating Rate (%)	70	80	90		95	

Holding Brake Electrical Specifications

Table 2.2 Holding Brakes with 90-VDC Rated Voltage (Standard)

Servomotor Model	Servomotor Capacity W	Holding Brake Specifications			
		Capacity W	Holding Torque N·m (lb in)	Coil Resistance Ω (at 20 °C)	Rated Current A (at 20 °C)
SGMAH-A3	30	6	0.196 (1.73)	1350	0.067
SGMAH-A5	50	6	0.196 (1.73)	1350	0.067
SGMAH-01	100	6	0.343 (3.04)	1350	0.067
SGMAH-02	200	6.5	1.47 (13)	1246	0.072
SGMAH-04	400	6.5	1.47 (13)	1246	0.072
SGMAH-08	750	6	2.45 (21.7)	1350	0.067

Table 2.3 Holding Brakes with 24-VDC Rated Voltage (Non-standard)

Servomotor Model	Servomotor Capacity W	Holding Brake Specifications			
		Capacity W	Holding Torque N·m (lb in)	Coil Resistance Ω (at 20 °C)	Rated Current A (at 20 °C)
SGMAH-A3	30	6	0.196 (1.73)	96	0.25
SGMAH-A5	50	6	0.196 (1.73)	96	0.25



◆ Holding Brake

The holding brake is automatically applied to the motor shaft when the shaft is installed vertically, to prevent the load from falling if the Servomotor power supply is turned OFF or is interrupted. It is only used to hold the load and cannot be used to stop the Servomotor.

Servomotor Ratings and Specifications

2.1.1 SGMAH Servomotors

Servomotor Model	Servomotor Capacity W	Holding Brake Specifications			
		Capacity W	Holding Torque N-m (lb-in)	Coil Resistance Ω (at 20 °C)	Rated Current A (at 20 °C)
SGMAH-01	100	6	0.343 (3.04)	96	0.25
SGMAH-02	200	6.5	1.47 (13)	89	0.27
SGMAH-04	400	6.5	1.47 (13)	89	0.27
SGMAH-08	750	6	2.45 (21.7)	96	0.25

SGMAH Servomotor Torque-motor Speed Characteristics

The torque-motor speed characteristics are shown below for the SGMAH Servomotors

● 200-V Servomotors

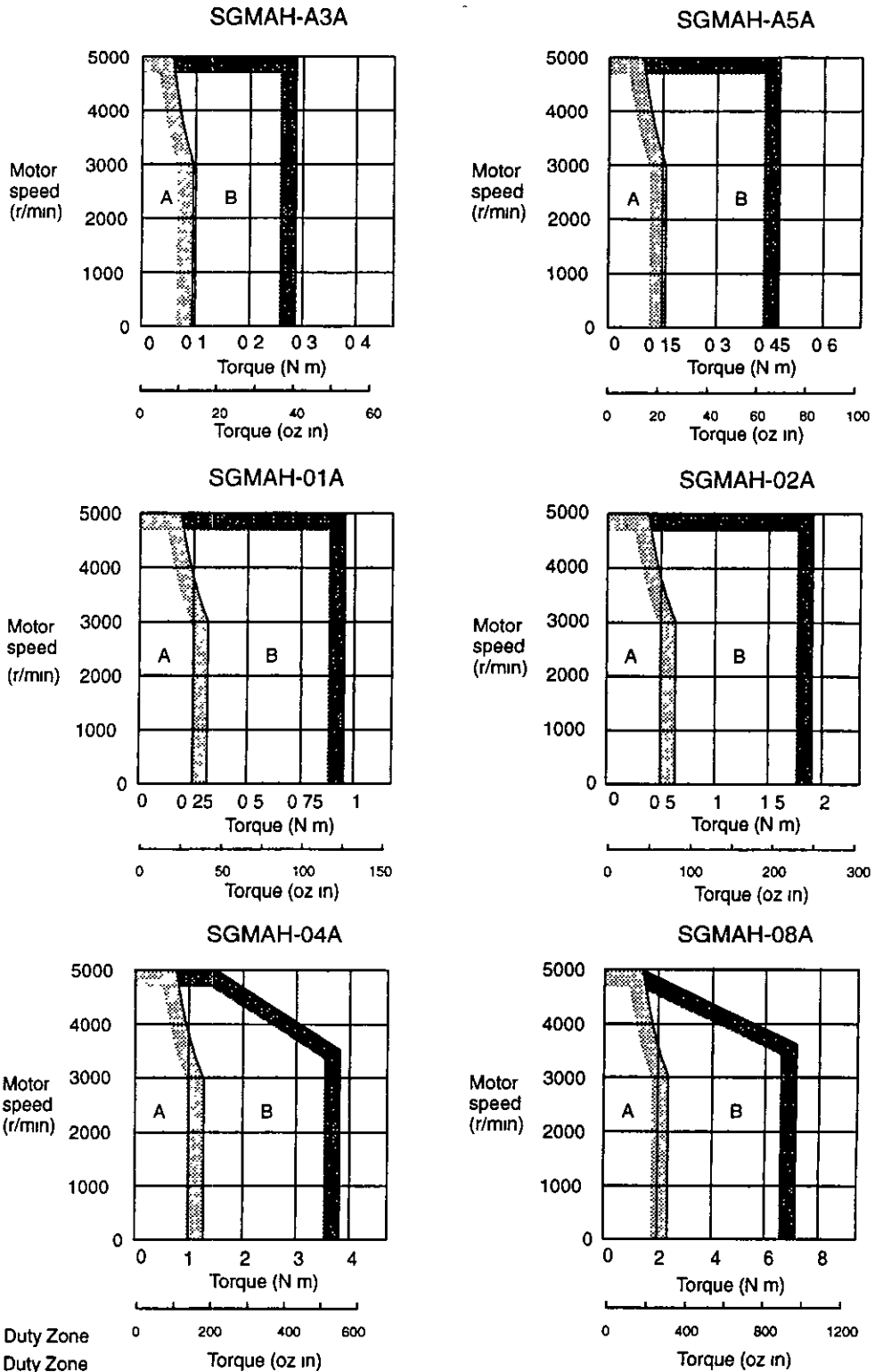

• 100-V Servomotors

SGMAH-A3B

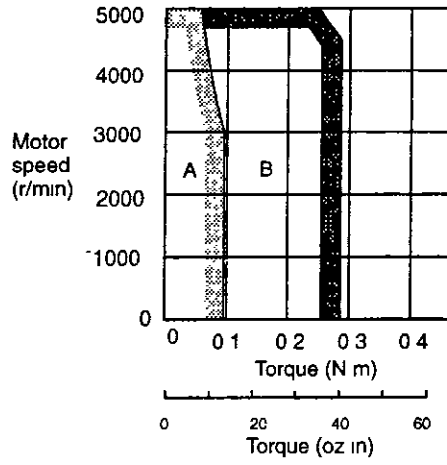

SGMAH-A5B

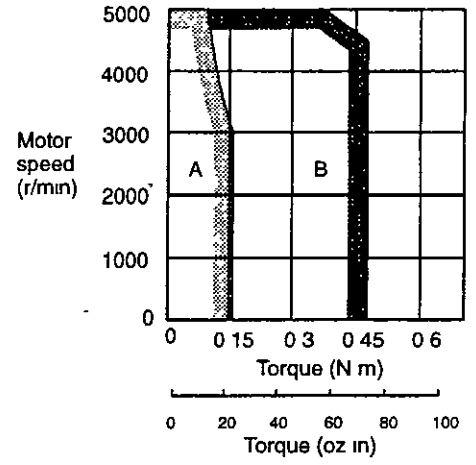

SGMAH-01B

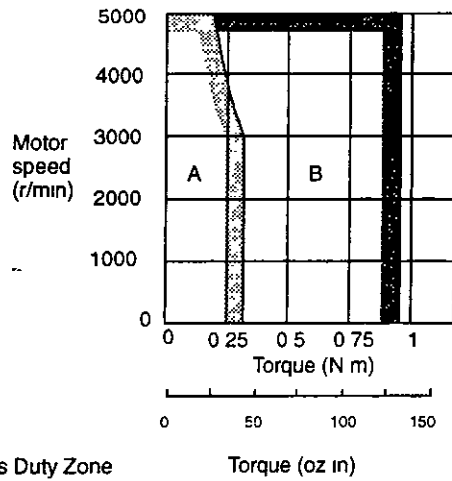

SGMAH-02B

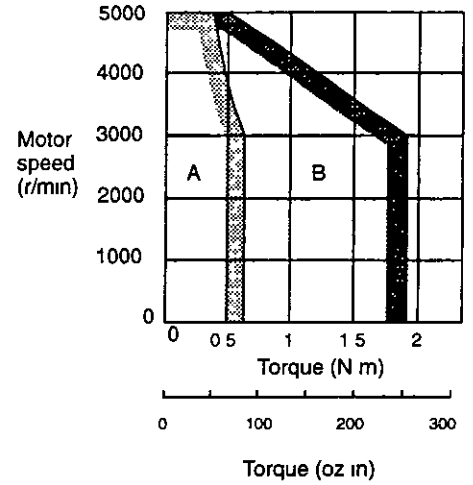

A Continuous Duty Zone
B Intermittent Duty Zone

■ Ratings and Specifications for SGMAH Servomotors with Standard Backlash Gears

- Time Rating Continuous
- Vibration Class 15 μm or below
- Insulation Resistance 500 VDC, 10 M Ω min
- Ambient Temperature 0 to 40°C
- Thermal Class B
- Withstand Voltage 1500 VAC for one minute
- Enclosure Totally enclosed, self cooled (except through sections of the shaft)
- Ambient Humidity 20% to 80% (with no condensation)
- Excitation Permanent magnet
- Drive Method Direct drive
- Backlash 15 to 20 min max
- Mounting Flange method
- Gear Mechanism Planetary gear mechanism

Table 2 4 Ratings and Specifications for SGMAH Servomotors with Standard Backlash Gears

Servomotor Model	Servomotor			Gear					
	Output W	Rated Speed r/min	Rated Torque N·m (oz·in)	Gear Ratio	Lost Motion	Rated Torque/Efficiency N m/% (oz in/%)	Instantaneous Peak Torque N·m (oz·in)	Rated Speed r/min	Max. Speed r/min *
SGMAH-A3□□AJ1□	30	3000	0 095 (13 45)	1/5	15	0 238/50 (33 7/50)	1 16 (164 3)	600	800
SGMAH-A3□□AJ3□				3/31		0 687/70 (97 3/70)	2 37 (336)	290	387
SGMAH-A3□□AJC□				1/21	20	1 60/80 (227/80)	5 48 (776)	143	190
SGMAH-A3□□AJ7□				1/33		2 51/80 (355/80)	8 61 (1219)	91	121
SGMAH-A5□□AJ1□	50		0 159 (22 5)	1/5	15	0 557/70 (78 9/70)	1 92 (272)	600	800
SGMAH-A5□□AJ3□				3/31		1 15/70 (162 8/70)	3 95 (559)	290	387
SGMAH-A5□□AJC□				1/21	20	2 67/80 (378/80)	9 07 (1284)	143	190
SGMAH-A5□□AJ7□				1/33		4 20/80 (595/80)	14 3 (2025)	91	121
SGMAH-01□□AJ1□	100		0 318 (45 0)	1/5	15	1 27/80 (179 8/80)	4 32 (612)	600	800
SGMAH-01□□AJ3□				3/31		2 63/80 (372/80)	8 88 (1257)	290	387
SGMAH-01□□AJC□				1/21		5 34/80 (756/80)	18 1 (2563)	143	190
SGMAH-01□□AJ7□				1/33		8 40/80 (1189/80)	28 4 (4021)	91	121

Servomotor Ratings and Specifications

2 1 1 SGMAH Servomotors

Servomotor Model	Servomotor			Gear					
	Output W	Rated Speed r/min	Rated Torque N m (oz-in)	Gear Ratio	Lost Motion	Rated Torque/Efficiency N m/% (oz in/%)	Instantaneous Peak Torque N m (oz-in)	Rated Speed r/min	Max. Speed r/min *
SGMAH-02□□AJ1□	200	3000	0.637 (90.2)	1/5	15	2.55/80 (361/80)	8.60 (1218)	600	800
SGMAH-02□□AJ3□				3/31		5.27/80 (746/80)	17.8 (2520)	290	387
SGMAH-02□□AJC□				1/21		10.7/80 (1515/80)	36.1 (5112)	143	190
SGMAH-02□□AJ7□				1/33		16.8/80 (2379/80)	56.7 (8029)	91	121
SGMAH-04A□□AJ1□	400		1.27 (179.8)	1/5	15	5.08/80 (719/80)	17.2 (2436)	600	800
SGMAH-04A□□AJ3□				3/31		10.5/80 (1487/80)	35.5 (5027)	290	387
SGMAH-04A□□AJC□				1/21		21.3/80 (3016/80)	72.2 (10224)	143	190
SGMAH-04A□□AJ7□				1/33		33.5/80 (4744/80)	113.0 (16001)	91	121
SGMAH-08A□□AJ1□	750		2.39 (338)	1/5	15	9.56/80 (1354/80)	32.0 (4531)	600	800
SGMAH-08A□□AJ3□				3/31		19.8/80 (2804/80)	66.6 (9431)	290	387
SGMAH-08A□□AJC□				1/21		40.2/80 (5692/80)	134 (18974)	143	190
SGMAH-08A□□AJ7□				1/33		63.1/80 (8935/80)	212 (30019)	91	121

* Maximum motor speed is up to 4000 (r/min) at the shaft

Servomotor Model	Gear		Servomotor Shaft Gear + Servomotor Moment of Inertia J x 10 ⁻⁴ kg·m ² (x 10 ⁻³ oz·in·s ²)
	Allowable Radial Load Fr [N (lbf)]	Allowable Thrust Load Fs [N (lbf)]	
SGMAH-A3□□AJ1□	145 (32.6)	125 (28.1)	0.044 (0.623)
SGMAH-A3□□AJ3□			0.033 (0.467)
SGMAH-A3□□AJC□	185 (41.6)		0.023 (0.326)
SGMAH-A3□□AJ7□			0.021 (0.297)
SGMAH-A5□□AJ1□	145 (32.6)	125 (28.1)	0.050 (0.708)
SGMAH-A5□□AJ3□	215 (48.3)		0.040 (0.566)
SGMAH-A5□□AJC□	230 (51.7)	145 (32.6)	0.036 (0.510)
SGMAH-A5□□AJ7□	245 (55.1)		0.032 (0.453)

Servomotor Model	Gear		Servomotor Shaft Gear + Servomotor Moment of Inertia J $\times 10^{-4} \text{ kg m}^2$ ($\times 10^{-3} \text{ oz-in-s}^2$)
	Allowable Radial Load Fr [N (lbf)]	Allowable Thrust Load Fs [N (lbf)]	
SGMAH-01□□AJ1□	175 (39 3)	145 (32 6)	0 099 (1 402)
SGMAH-01□□AJ3□	215 (48 3)		0 054 (0 765)
SGMAH-01□□AJC□	455 (102 3)	235 (52 8)	0 071 (1 005)
SGMAH-01□□AJ7□	480 (107 9)		0 057 (0 807)
SGMAH-02□□AJ1□	275 (61 8)	235 (52 8)	0 299 (4 23)
SGMAH-02□□AJ3□	360 (80 9)		0 196 (2 78)
SGMAH-02□□AJC□	585 (131 5)	290 (65 2)	0 211 (2 99)
SGMAH-02□□AJ7□	635 (142 8)		0 181 (2 56)
SGMAH-04A□□AJ1□	275 (61 8)	235 (52 8)	0 366 (5 18)
SGMAH-04A□□AJ3□	460 (103 4)		0 353 (5 00)
SGMAH-04A□□AJC□	655 (147 3)	310 (69 7)	0 403 (5 71)
SGMAH-04A□□AJ7□	755 (169 7)		0 338 (4 79)
SGMAH-08A□□AJ1□	355 (79 8)	290 (65 2)	1 12 (15 86)
SGMAH-08A□□AJ3□	525 (118 0)		1 10 (15 58)
SGMAH-08A□□AJC□	1070 (240 5)	490 (110 2)	1 15 (16 29)
SGMAH-08A□□AJ7□	1205 (270 9)		0 972 (13 76)

Fr Radial Load

Fs Thrust Load

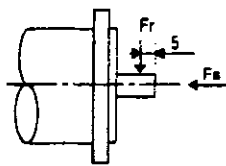

Note Output torque and motor speed produce the following trends in efficiency. Values in the table are at the motor's rated torque and rated motor speed (3000 r/min)

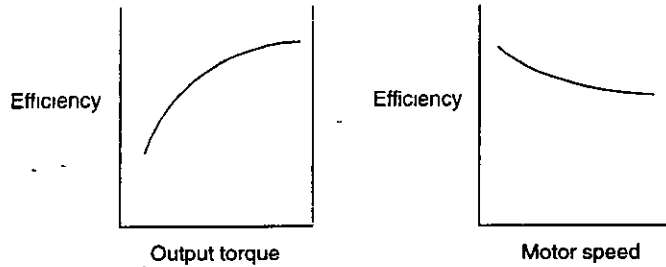

Item	Measurement Method/Definition	Typical Value
Rated Input Motor Speed	-	3000 (r/min)
Max. Allowable Input Motor Speed	-	4000 (r/min)
Rated Torque	The rated output torque of the motor is the gear input torque. The rated torque is this value multiplied by the gear ratio and efficiency	
Lost Motion *	Angular difference in the screw with a $\pm 5\%$ rated torque load (Maximum value at any four positions during output)	20 (arc-min) max
Torsion Rigidity *	Highest torsion angle value on one side with a \pm rated torque load	27 (arc-min) max
Angular Transmission Error Accuracy	Difference in absolute accuracy for one rotation under load and no-load conditions during output	15 (arc-min) max

* See the figure below for lost motion and torsion rigidity

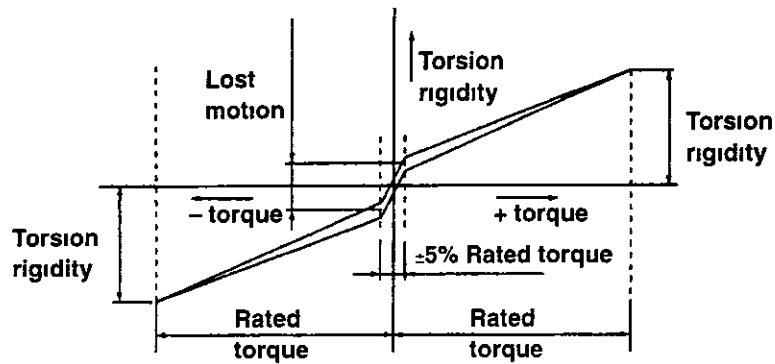

■ Ratings and Specifications for SGMAH Servomotors with Low-backlash Gears

- Time Rating Continuous
- Vibration Class 15 μ m or below
- Insulation Resistance 500 VDC, 10 M Ω min
- Ambient Temperature 0 to 40°C
- Thermal Class B
- Withstand Voltage 1500 VAC for one minute
- Enclosure Totally enclosed, self cooled (except through sections of the shaft)
- Ambient Humidity 20% to 80% (with no condensation)
- Drive Method Direct drive
- Backlash 3 min max
- Excitation Permanent magnet
- Mounting Flange method
- Gear Mechanism Planetary gear mechanism

Table 2.5 Ratings and Specifications for SGMAH Servomotors with Low-backlash Gears

Servomotor Model	Servomotor			Gear					
	Output W	Rated Speed r/min	Rated Torque N·m (oz·in)	Gear Ratio	Lost Motion	Rated Torque/Efficiency N·m/% (oz·in/%)	Instantaneous Peak Torque N·m (oz·in)	Rated Speed r/min	Max. Speed r/min *1
SGMAH-A3□□AG1□	30	3000	0.095 (13.45)	1/5	3	0.238/50 (33.7/50)	1.16 (164.3)	600	800
SGMAH-A3□□AG2□				1/9		0.599/70 (84.8/70)	2.35 (333)	333	444
SGMAH-A3□□AGCC□				1/21		1.60/80 (227/80)	5.48 (776)	143	190
SGMAH-A3□□AG7□				1/33		2.51/80 (355/80)	8.61 (1219)	91	121
SGMAH-A5□□AG1□	50		0.159 (22.5)	1/5	3	0.557/70 (78.9/70)	1.92 (272)	600	800
SGMAH-A5□□AG2□				1/9		1.00/70 (141.6/70)	3.89 (551)	333	444
SGMAH-A5□□AGCC□				1/21		2.67/80 (378/80)	9.07 (1284)	143	190
SGMAH-A5□□AG7□				1/33		4.20/80 (595/80)	14.3 (2025)	91	121
SGMAH-01□□AG1□	100		0.318 (45.0)	1/5	3	1.27/80 (179.8/80)	4.32 (612)	600	800
SGMAH-01□□AGB□				1/11		2.80/80 (396/80)	9.5 (1345)	273	363
SGMAH-01□□AGCC□				1/21		5.34/80 (756/80)	18.1 (2563)	143	190
SGMAH-01□□AG7□				1/33		8.40/80 (1189/80)	27.*2 (3823)	91	121
SGMAH-02□□AG1□	200		0.637 (90.2)	1/5	3	2.55/80 (361/80)	8.6 (1218)	600	800
SGMAH-02□□AGB□				1/11		5.61/80 (794/80)	18.9 (2676)	273	363

Servomotor Ratings and Specifications

2 1 1 SGMAH Servomotors

Servomotor Model	Servomotor			Gear					
	Output W	Rated Speed r/min	Rated Torque N m (oz-in)	Gear Ratio	Lost Motion	Rated Torque/Efficiency N m/% (oz in/%)	Instantaneous Peak Torque N m (oz in)	Rated Speed r/min	Max Speed r/min *1
SGMAH-02□□AGC□	200	3000	0 637 (90 2)	1/21	3	10 7/80 (1515/80)	36 1 (5112)	143	190
SGMAH-02□□AG7□				1/33		16 8/80 (2379/80)	48 *2 (6797)	91	121
SGMAH-04A□□AG1□	400		1 27 (179 8)	1/5	3	5 08/80 (719/80)	17 2 (2436)	600	800
SGMAH-04A□□AGB□				1/11		11 2/80 (1586/80)	35 *2 (4956)	273	363
SGMAH-04A□□AGC□				1/21		21 3/80 (3016/80)	72 2 (10224)	143	190
SGMAH-04A□□AG7□				1/33		33 5/80 (4744/80)	93 *2 (13169)	91	121
SGMAH-08A□□AG1□				750			2 39 (338)	1/5	3
SGMAH-08A□□AGB□	1/11	21 0/80 (2973/80)	56 *2 (7930)		273			363	
SGMAH-08A□□AGC□	1/21	40 2/80 (5692/80)	134 (18974)		143			190	
SGMAH-08A□□AG7□	1/33	63 1/80 (8935/80)	156 *2 (22090)		91			121	

* 1 Maximum motor speed is up to 4000 (r/min) at the shaft

* 2 Gear output torque is expressed using by the following equation
 (Gear output torque) = (Servomotor output torque) × (gear ratio) × (efficiency)

The instantaneous peak torque values indicated with *2 are limited by the gear so use the following Servomotor instantaneous peak torque In this case, set torque limit user constants Pn402 and 403 for the Servopack at 250%

Servomotor Model	Gear		Servomotor Shaft Gear + Servomotor Moment of Inertia J x 10 ⁻⁴ kg·m ² (x 10 ⁻³ oz in s ²)
	Allowable Radial Load Fr [N (lbf)]	Allowable Thrust Load Fs [N (lbf)]	
SGMAH-A3□□AG1□	137 (30 8)	127 (28 6)	0 053 (0 751)
SGMAH-A3□□AG2□	176 (39 6)		0 029 (0 411)
SGMAH-A3□□AGC□	176 (39 6)		0 025 (0 354)
SGMAH-A3□□AG7□	176 (39 6)		0 023 (0 326)
SGMAH-A5□□AG1□	137 (30 8)	127 (28 6)	0 058 (0 821)
SGMAH-A5□□AG2□	206 (46 3)	147 (33 0)	0 055 (0 779)
SGMAH-A5□□AGC□	235 (52 8)		0 040 (0 566)
SGMAH-A5□□AG7□	235 (52 8)		0 030 (0 425)
SGMAH-01□□AG1□	167 (37 5)	147 (33 0)	0 123 (1 742)
SGMAH-01□□AGB□	216 (48 6)		0 078 (1 105)

Servomotor Model	Gear		Servomotor Shaft Gear + Servomotor Moment of Inertia J $\times 10^{-4} \text{ kg m}^2$ ($\times 10^{-3} \text{ oz in s}^2$)
	Allowable Radial Load Fr [N (lbf)]	Allowable Thrust Load Fs [N (lbf)]	
SGMAH-01□□AGC□	392 (88 1)	235 (52 8)	0 080 (1 133)
SGMAH-01□□AG7□	431 (96 9)		0 062 (0 878)
SGMAH-02□□AG1□	245 (55 1)	235 (52 8)	0 396 (5 61)
SGMAH-02□□AGB□	323 (72 6)		0 209 (2 96)
SGMAH-02□□AGC□	549 (123 4)	294 (66 1)	0 195 (2 76)
SGMAH-02□□AG7□	608 (136 7)		0 161 (2 28)
SGMAH-04A□□AG1□	245 (55 1)		235 (52 8)
SGMAH-04A□□AGB□	441 (99 1)	294(66 1)	0 404 (5 72)
SGMAH-04A□□AGC□	568 (127 7)	314 (70 6)	0 395 (5 59)
SGMAH-04A□□AG7□	657 (147 7)		0 311 (4 40)
SGMAH-08A□□AG1□	343 (77 1)	294 (66 1)	1 31 (18 55)
SGMAH-08A□□AGB□	451 (101 4)	314 (70 6)	1 23 (17 42)
SGMAH-08A□□AGC□	813 (182 7)	490 (110 2)	1 23 (17 42)
SGMAH-08A□□AG7□	921 (207)		1 00 (14 16)

Fr Radial Load
Fs Thrust Load

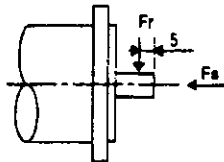

Note Output torque and motor speed produce the following trends in efficiency. Values in the table are at the rated motor torque and rated motor speed (3000 r/min)

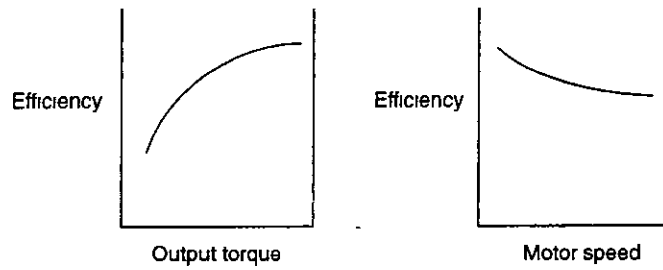

Noise Data

The following noise data for an Σ -series AC Servomotor with a gear is for reference only and it may vary slightly with the capacity and gear ratio of the Servomotor

Measuring Conditions

- Scale A: 50 cm
- Ground Noise: 28 dB

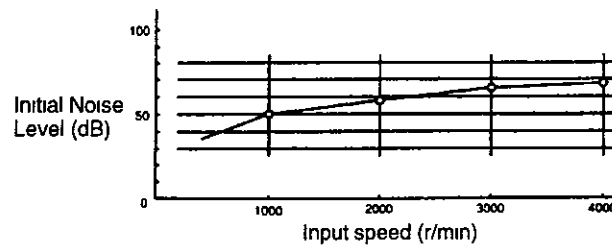

Item	Measurement Method/Definition	Typical Value
Rated Input Motor Speed	-	3000 (r/min)
Max Allowable Input Motor Speed	-	4000 (r/min)
Rated Torque	The rated output torque of the motor is the gear input torque. The rated torque is this value multiplied by the gear ratio and efficiency	
Lost Motion *	Angular difference in the screw with a $\pm 5\%$ rated torque load (Maximum value at any four positions during output)	3 (arc-min) max
Torsion Rigidity *	Highest torsion angle value on one side with a \pm rated torque load	10 (arc-min) max
Angular Transmission Error Accuracy	Difference in absolute accuracy for one rotation under load and no-load conditions during output	6 (arc-min) max

* See the figure below for lost motion and torsion rigidity

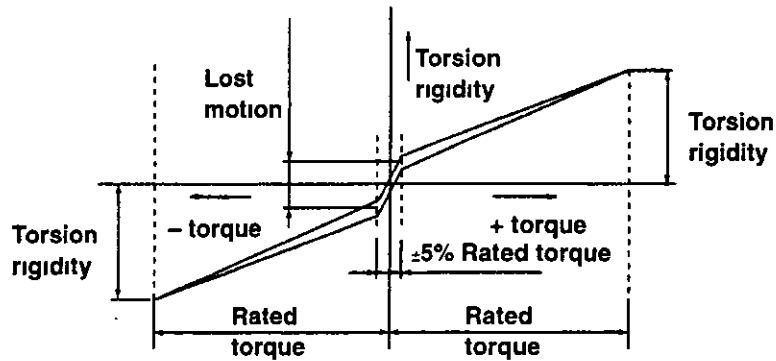

2.1.2 SGMPH Servomotors

■ Rating and Specifications for Standard Servomotors without Gears

- Time Rating Continuous
- Vibration Class 15 μ m or below
- Insulation Resistance 500 VDC, 10 M Ω min
- Ambient Temperature 0 to 40°C
- Excitation Permanent magnet
- Mounting Flange method
- Thermal Class B
- Withstand Voltage 1500 VAC for one minute
- Enclosure Totally enclosed, self-cooled, IP55 (except through sections of the shaft)
- Ambient Humidity 20% to 80% (with no condensation)
- Drive Method Direct drive

Table 2 6 . SGMPH Standard Servomotor Ratings and Specifications

Voltage		200 V					100 V	
Servomotor Model		01A	02A	04A	08A	15A	01B	02B
SGMAH-								
Rated Output *1	kW	0.1	0.2	0.4	0.75	1.5	0.1	0.2
Rated Torque *1,2	N m	0.318	0.637	1.27	2.39	4.77	0.318	0.637
	oz in	45.1	90.2	180	338	676	45.1	90.2
Instantaneous Peak Torque *1	N m	0.955	1.91	3.82	7.16	14.3	0.955	1.91
	oz in	135	270	541	1010	2030	135.2	270
Rated Current *1	A (rms)	0.89	2.0	2.6	4.1	7.5	2.2	2.7
Instantaneous Max. Current *1	A (rms)	2.8	6.0	8.0	13.9	23.0	7.1	8.4
Rated Speed *1	r/min	3000						
Max. Speed *1	r/min	5000						
Torque Constant	N m/A (rms)	0.392	0.349	0.535	0.641	0.687	0.160	0.258
	oz in /A (rms)	55.6	49.4	75.8	91.0	97.4	22.8	36.5
Moment of Inertia J	$\times 10^{-4}$ kg m ²	0.0491	0.193	0.331	2.10	4.02	0.0491	0.193
	$\times 10^{-3}$ oz in s ²	0.695	2.73	4.69	29.7	56.9	0.695	2.73
Rated Power Rate *1	kW/s	20.6	21.0	49.0	27.1	56.7	20.6	21.0
Rated Angular Acceleration *1	rad/s ²	64800	33000	38500	11400	11900	64800	33000
Moment of Inertia Time Constant	ms	0.53	0.54	0.36	0.66	0.46	0.56	0.64
Inductive Time Constant	ms	3.7	7.4	8.6	18	22	3.6	6.3

* 1 These items and torque-motor speed characteristics quoted in combination with an SGDM Servopack are at an armature winding temperature of 100°C. Other values quoted at 20°C. All values typical.

* 2 Rated torques are continuous allowable torque values at 40°C with a heat sink attached

Heat sink dimensions

250 × 250 × 6 (mm), (10 × 10 × 0.25 (in)) 0.1 kW to 0.4 kW

300 × 300 × 12 (mm), (12 × 12 × 0.5 (in)) 0.75 kW to 1.5 kW

Note 1. Add the numerical values given below to the moment of inertia in the table for Servomotors fitted with a holding brake. Other specifications will also change slightly

Servomotor Model SGMPH-		01A 01B	02A 02B	04A	08A	15A
Holding Brake	$\times 10^{-4} \text{ kg m}^2$	0.029	0.109		0.875	
	$\times 10^{-3} \text{ oz-in s}^2$	0.411	1.544		12.39	

2 Use the following reduction ratings when a motor is fitted with a shaft seal because of the higher friction torque. Other specifications will also change slightly

Servomotor Model SGMPH-		01A 01B	02A 02B	04A	08A	15A
Derating Rate (%)		90			95	

Holding Brake Electrical Specifications

Table 2.7 Holding Brake with 90-VDC Rated Voltage (Standard)

Servomotor	Servomotor Capacity W	Holding Brake Specifications			
		Capacity W	Holding Torque N m (lb in)	Coil Resistance Ω (at 20 °C)	Rated Current A (at 20 °C)
SGMPH-01	100	6	0.49 (4.34)	1550	0.058
SGMPH-02	200	5	0.98 (8.67)	1620	0.056
SGMPH-04	400	7.6	1.96 (17.3)	1066	0.085
SGMPH-08	750	7.5	3.65 (32.1)	1083	0.083
SGMPH-15	1500	10	7.15 (63.3)	832	0.108

Table 2.8 Holding Brake with 24-VDC Rated Voltage (Non-standard)

Servomotor	Servomotor Capacity W	Holding Brake Specifications			
		Capacity W	Holding Torque N m (lb in)	Coil Resistance Ω (at 20 °C)	Rated Current A (at 20 °C)
SGMPH-01	100	6	0.49 (4.34)	96	0.25
SGMPH-02	200	5	0.98 (8.67)	115	0.21
SGMPH-04	400	7.6	1.96 (17.3)	76	0.32
SGMPH-08	750	7.5	3.65 (32.1)	77	0.31
SGMPH-15	1500	10	7.15 (63.3)	58	0.42

SGMPH Servomotor Torque-motor Speed Characteristics

The torque-motor speed characteristics are shown below for the SGMPH Servomotors

• 200-V Servomotors

SGMPH-01A

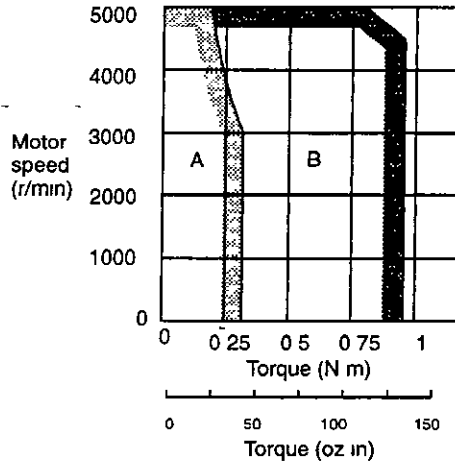

SGMPH-02A

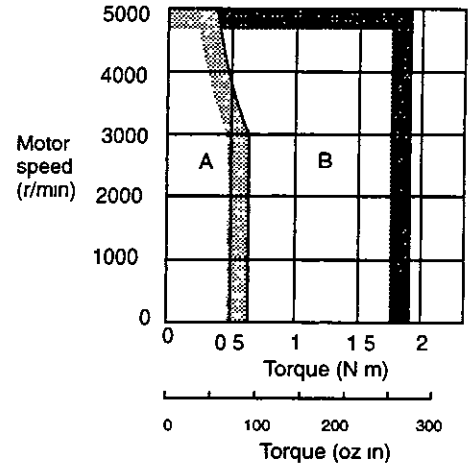

SGMPH-04A

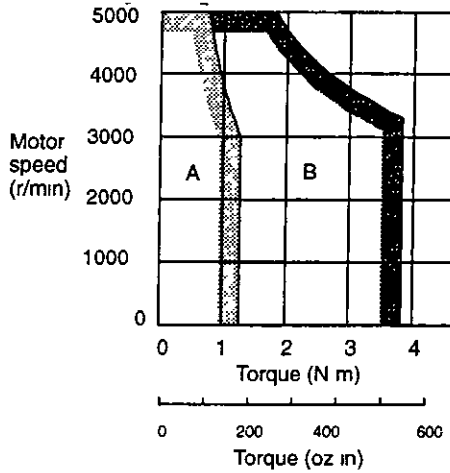

SGMPH-08A

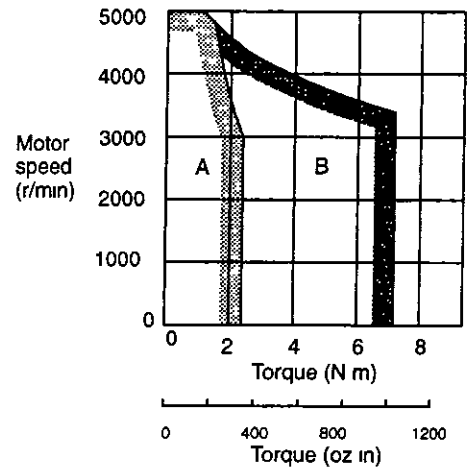

SGMPH-15A

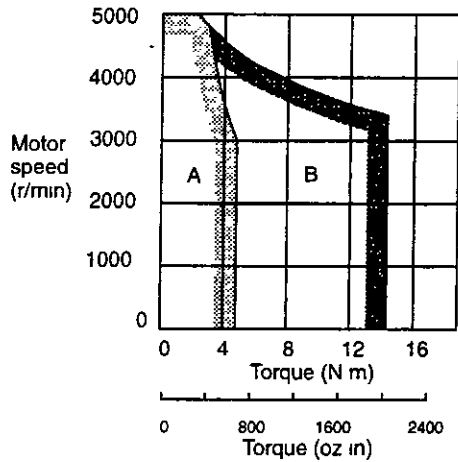

A Continuous Duty Zone
B Intermittent Duty Zone

• 100-V Servomotors

SGMPH-01B

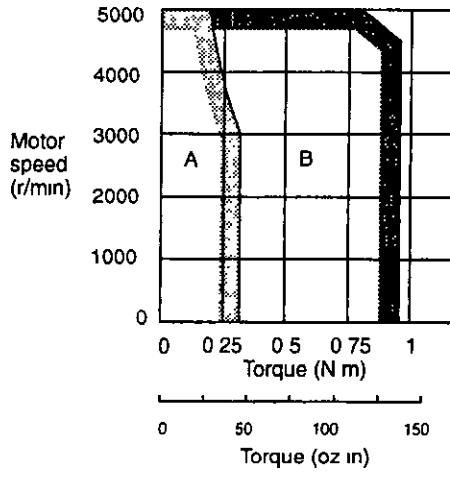

SGMPH-02B

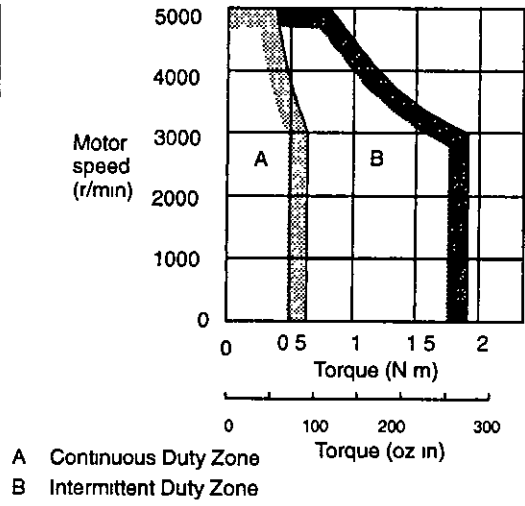

A Continuous Duty Zone
 B Intermittent Duty Zone



■ Ratings and Specifications for SGMPH Servomotors with Standard Backlash Gears

- Time Rating Continuous
- Vibration Class 15 µm or below
- Insulation Resistance 500 VDC, 10 MΩ min
- Ambient Temperature 0 to 40°C
- Excitation Permanent magnet
- Mounting Flange method
- Gear Mechanism Planetary gear mechanism
- Thermal Class B
- Withstand Voltage 1500 VAC for one minute
- Enclosure Totally enclosed, self-cooled (except through sections of the shaft)
- Ambient Humidity 20% to 80% (with no condensation)
- Drive Method Direct drive
- Backlash 15 min max

Table 2.9 Ratings and Specifications for an SGMPH Servomotor with Standard-backlash Gears

Servomotor Model	Servomotor			Gear					
	Output W	Rated Speed r/min	Rated Torque N·m (oz in)	Gear Ratio	Lost Motion	Rated Torque/Efficiency N m/% (oz in/%)	Instantaneous Peak Torque N·m (oz in)	Rated Speed r/min	Max. Speed r/min *
SGMPH-01□□AJ1□	100	3000	0.318 (45.0)	1/5	15	1.27/80 (179.8/80)	4.32 (612)	600	800
SGMPH-01□□AJ3□				3/31		2.63/80 (372/80)	8.88 (1257)	290	387
SGMPH-01□□AJC□				1/21		5.34/80 (756/80)	18.1 (2563)	143	190
SGMPH-01□□AJ7□				1/33		8.40/80 (1189/80)	28.4 (4021)	91	121
SGMPH-02□□AJ1□	200		0.637 (90.2)	1/5	15	2.55/80 (361/80)	8.6 (1218)	600	800
SGMPH-02□□AJ3□				3/31		5.27/80 (746/80)	17.8 (2520)	290	387
SGMPH-02□□AJC□				1/21		10.7/80 (1515/80)	36.1 (5112)	143	190
SGMPH-02□□AJ7□				1/33		16.8/80 (2379/80)	56.7 (8029)	91	121
SGMPH-04A□AJ1□	400		1.27 (179.8)	1/5	15	5.08/80 (719/80)	17.2 (2436)	600	800
SGMPH-04A□AJ3□				3/31		10.5/80 (1487/80)	35.5 (5027)	290	387
SGMPH-04A□AJC□				1/21		21.3/80 (3016/80)	72.2 (10224)	143	190
SGMPH-04A□AJ7□				1/33		33.5/80 (4744/80)	113 (16001)	91	121

Servomotor Model	Servomotor			Gear					
	Output W	Rated Speed r/min	Rated Torque N m (oz in)	Gear Ratio	Lost Motion	Rated Torque/Efficiency N m/% (oz in/%)	Instantaneous Peak Torque N-m (oz in)	Rated Speed r/min	Max. Speed r/min *
SGMPH-08A□AJ1□	750	3000	2.39 (338)	1/5	15	9.56/80 (1354/80)	32 (4531)	600	800
SGMPH-08A□AJ3□				3/31		19.8/80 (2804/80)	66.6 (9431)	290	387
SGMPH-08A□AJC□				1/21		40.2/80 (5692/80)	134 (18974)	143	190
SGMPH-08A□AJ7□				1/33		63.1/80 (8935/80)	213 (30161)	91	121
SGMPH-15A□AJ1□	1500		4.77 (675)	1/5	15	19.1/80 (2705/80)	64.4 (9119)	600	800
SGMPH-15A□AJB□				15/167		42.5/80 (6018/80)	144 (20390)	269	359
SGMPH-15A□AJC□				1/21		80.1/80 (11342/80)	270 (38232)	143	190
SGMPH-15A□AJ7□				1/33		126/80 (17842/80)	425 (60180)	91	121

* Maximum motor speed is up to 4000 (r/min) at the shaft

Servomotor Ratings and Specifications

2 1 2 SGMPH Servomotors

Servomotor Model	Gear		Servomotor Shaft Gear + Servomotor Moment of Inertia J $\times 10^{-4} \text{ kg}\cdot\text{m}^2$ ($\times 10^{-3} \text{ oz in s}^2$)
	Allowable Radial Load F_r [N (lbf)]	Allowable Thrust Load F_s [N (lbf)]	
SGMPH-01□□AJ1□	175 (39 3)	145 (32 6)	0 112 (15 86)
SGMPH-01□□AJ3□	215 (48 3)		0 067 (9 49)
SGMPH-01□□AJC□	455 (102 3)	235 (52 8)	0 084 (11 89)
SGMPH-01□□AJ7□	480 (107 9)		0 070 (9 91)
SGMPH-02□□AJ1□	275 (61 8)	235 (52 8)	0 386 (54 7)
SGMPH-02□□AJ3□	360 (80 9)		0 283 (40 1)
SGMPH-02□□AJC□	585 (131 5)	290 (65 2)	0 298 (42 2)
SGMPH-02□□AJ7□	635 (142 7)		0 268 (37 9)
SGMPH-04A□AJ1□	275 (61 8)	235 (52 8)	0 524 (74 2)
SGMPH-04A□AJ3□	460 (103 4)		0 511 (72 4)
SGMPH-04A□AJC□	655 (147 3)	310 (69 7)	0 561 (79 4)
SGMPH-04A□AJ7□	755 (169 7)		0 496 (70 2)
SGMPH-08A□AJ1□	355 (79 8)	290 (65 2)	2 55 (361)
SGMPH-08A□AJ3□	525 (118 0)		2 53 (358)
SGMPH-08A□AJC□	1070 (240 5)	490 (110 2)	2 58 (365)
SGMPH-08A□AJ7□	1205 (270 9)		2 40 (340)
SGMPH-15A□AJ1□	400 (89 9)	310 (69 7)	4 97 (704)
SGMPH-15A□AJB□	860 (193 3)		5 27 (746)
SGMPH-15A□AJC□	1690 (380)	880 (197 8)	5 33 (755)
SGMPH-15A□AJ7□	1690 (380)		4 82 (683)

F_r Radial Load
 F_s Thrust Load

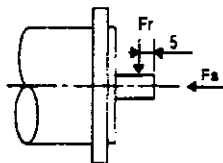

Note Output torque and motor speed produce the following trends in efficiency. Values in the table are at the rated motor torque and rated motor speed (3000 r/min)

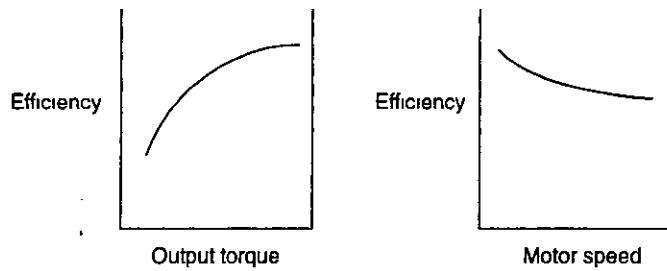

Item	Measurement Method/Definition	Typical Value
Rated Input Motor Speed	-	3000 (r/min)
Max. Allowable Input Motor Speed	-	4000 (r/min)
Rated Torque	The rated output torque is of the motor is the gear input torque. The rated torque is this value multiplied by the gear ratio and efficiency	
Lost Motion *	Angular difference in the screw with a $\pm 5\%$ rated torque load (Maximum value at any four positions during output)	15 (arc-min) max
Torsion Rigidity *	Highest torsion angle value on one side with a \pm rated torque load	27 (arc-min) max
Angular Transmission Error Accuracy	Difference in absolute accuracy for one rotation under load and no-load conditions during output	15 (arc-min) max

* See the figure below for lost motion and torsion rigidity

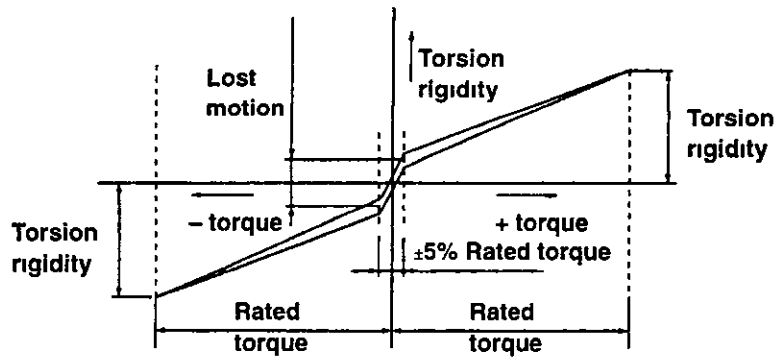

■ Ratings and Specifications for SGMPH Servomotors with Low-backlash Gears

- Time Rating Continuous
- Vibration Class 15 µm or below
- Insulation Resistance 500 VDC, 10 MΩ min
- Ambient Temperature 0 to 40°C
- Excitation Permanent magnet
- Mounting Flange method
- Gear Mechanism Planetary gear mechanism
- Thermal Class B
- Withstand Voltage 1500 VAC for one minute
- Enclosure Totally enclosed, self-cooled (except through sections of the shaft)
- Ambient Humidity 20% to 80% (with no condensation)
- Drive Method Direct drive
- Backlash 3 min max

Table 2 10 Ratings and Specifications for SGMPH Servomotors with Low-backlash Gears

Servomotor Model	Servomotor			Gear					
	Output W	Rated Speed r/min	Rated Torque N m (oz-in)	Gear Ratio	Lost Motion	Rated Torque/Efficiency N m/% (oz in/%)	Instantaneous Peak Torque N m (oz-in)	Rated Speed r/min	Max. Speed r/min *1
SGMPH-01□□AG1□	100	3000	0 318 (45 0)	1/5	3	1 27/80 (179 8/80)	4 32 (612)	600	800
SGMPH-01□□AGB□				1/11		2 80/80 (396/80)	9 5 (1345)	290	363
SGMPH-01□□AGC□				1/21		5 34/80 (756/80)	18 1 (2563)	143	190
SGMPH-01□□AG7□				1/33		8 40/80 (1189/80)	27 0 *2 (3823)	91	121
SGMPH-02□□AG1□	200		0 637 (90 2)	1/5	3	2 55/80 (361/80)	8 6 (1218)	600	800
SGMPH-02□□AGB□				1/11		5 61/80 (794/80)	18 9 (2676)	290	363
SGMPH-02□□AGC□				1/21		10 7/80 (1515/80)	36 1 (5112)	143	190
SGMPH-02□□AG7□				1/33		16 8/80 (2379/80)	48 0 *2 (6797)	91	121
SGMPH-04A□AG1□	400		1 27 (179 8)	1/5	3	5 08/80 (719/80)	17 2 (2436)	600	800
SGMPH-04A□AGB□				1/11		8 38/80 (1187/80)	35 0 *2 (4956)	290	363
SGMPH-04A□AGC□				1/21		21 3/80 (3016/80)	72 2 (10224)	143	190
SGMPH-04A□AG7□				1/33		33 5/80 (4744/80)	93 0 *2 (13169)	91	121

Servomotor Model	Servomotor			Gear					
	Output W	Rated Speed r/min	Rated Torque N m (oz in)	Gear Ratio	Lost Motion	Rated Torque/Efficiency N m/% (oz in/%)	Instantaneous Peak Torque N·m (oz in)	Rated Speed r/min	Max. Speed r/min *1
SGMPH-08A□AG1□	750	3000	2.39 (338)	1/5	3	9.56/80 (1354/80)	32 (4531)	600	800
SGMPH-08A□AGB□				1/11		21.0/80 (2974/80)	56.0 *2 (7930)	290	363
SGMPH-08A□AGC□				1/21		40.2/80 (5692/80)	134 (18974)	143	190
SGMPH-08A□AG7□				1/33		63.1/80 (8935/80)	156 *2 (22090)	91	121
SGMPH-15A□AG1□	1500		4.77 (675)	1/5	3	19.1/80 (2705/80)	64.4 (9119)	600	800
SGMPH-15A□AGB□				1/11		42.0/80 (5947/80)	142 (20107)	290	363
SGMPH-15A□AGC□				1/21		80.1/80 (11342/80)	270 (38232)	143	190
SGMPH-15A□AG7□				1/33		126/80 (17842/80)	353 *2 (49985)	91	121

* 1 Maximum motor speed is up to 4000 (r/min) at the shaft

* 2 Gear output torque is expressed using the following equation

$$(\text{Gear output torque}) = (\text{Servomotor output torque}) \times (\text{gear ratio}) \times (\text{efficiency})$$

The instantaneous peak torque values indicated by *2 are limited by the gear, so use the following Servomotor instantaneous peak torque. In this case, set torque limit user constants Pn402 and Pn403 for the Servopack at 250%

Servomotor Model	Gear		Servomotor Shaft Gear + Servomotor Moment of Inertia J x 10 ⁻⁴ kg·m ² (x 10 ⁻³ oz·in s ²)
	Allowable Radial Load Fr [N (lbf)]	Allowable Thrust Load Fs [N (lbf)]	
SGMPH-01□□AG1□	167 (37.5)	147 (33.0)	0.135 (1.912)
SGMPH-01□□AGB□	216 (48.6)		0.091 (1.289)
SGMPH-01□□AGC□	392 (88.1)	235 (52.8)	0.092 (1.303)
SGMPH-01□□AG7□	431 (96.9)		0.075 (1.062)
SGMPH-02□□AG1□	245 (55.1)	235 (52.8)	0.483 (6.84)
SGMPH-02□□AGB□	323 (72.6)		0.296 (4.19)
SGMPH-02□□AGC□	549 (123.4)	294 (66.1)	0.282 (3.99)
SGMPH-02□□AG7□	608 (136.7)		0.248 (3.51)
SGMPH-04A□AG1□	245 (55.1)	235 (52.8)	0.621 (8.79)
SGMPH-04A□AGB□	441 (99.1)	294 (66.1)	0.562 (7.96)

Servomotor Ratings and Specifications

2 1 2 SGMPH Servomotors

Servomotor Model	Gear		Servomotor Shaft Gear + Servomotor Moment of Inertia J $\times 10^{-4} \text{ kg}\cdot\text{m}^2$ ($\times 10^{-3} \text{ oz}\cdot\text{in s}^2$)
	Allowable Radial Load F_r [N (lbf)]	Allowable Thrust Load F_s [N (lbf)]	
SGMPH-04A□AGC□	568 (127 7)	314 (70 6)	0 553 (7 83)
SGMPH-04A□AG7□	657 (147 7)		0 469 (6 64)
SGMPH-08A□AG1□	343 (77 1)	294 (66 1)	2 73 (38 7)
SGMPH-08A□AGB□	451 (101 4)	314 (70 6)	2 66 (37 7)
SGMPH-08A□AGC□	813 (182 8)	490 (110 2)	2 66 (37 7)
SGMPH-08A□AG7□	921 (207)		2 43 (34 4)
SGMPH-15A□AG1□	353 (79 4)	314 (70 6)	5 80 (82 1)
SGMPH-15A□AGB□	647 (145 5)	490 (110 2)	5 69 (80 6)
SGMPH-15A□AGC□	1274 (286)	882 (198 3)	6 00 (85 0)
SGMPH-15A□AG7□			5 14 (72 8)

F_r Radial Load
 F_s Thrust Load

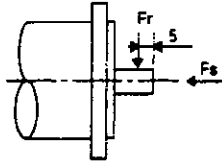

Note Output torque and motor speed produce the following trends in efficiency. Values in the table are at the rated motor torque and rated motor speed (3000 r/min)

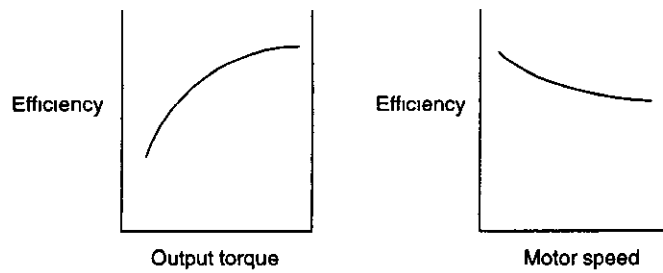

Noise Data

The following noise data for Σ -series AC Servomotors with gear is for reference only and it may vary slightly with the capacity and gear ratio of the Servomotors

Measuring Conditions

- Scale A: 50 cm
- Ground Noise: 28 dB

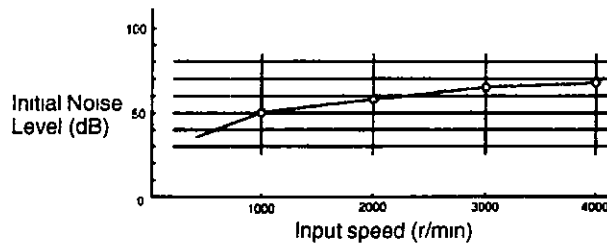

Servomotor Ratings and Specifications

2 1 2 SGMPH Servomotors

Item	Measurement Method/Definition	Typical Value
Rated Input Motor Speed	-	3000 (r/min)
Max Allowable Input Motor Speed	-	4000 (r/min)
Rated Torque	The rated output torque of the motor is the gear input torque. The rated torque is this value multiplied by the gear ratio and efficiency.	
Lost Motion *	Angular difference in the screw with a $\pm 5\%$ rated torque load (Maximum value at any four positions during output)	3 (arc-min) max
Torsion Rigidity *	Highest torsion angle value on one side with a \pm rated torque load	10 (arc-min) max
Angular Transmission Error Accuracy	Difference in absolute accuracy for one rotation under load and no-load conditions during output	6 (arc-min) max

* See the figure below for lost motion and torsion rigidity

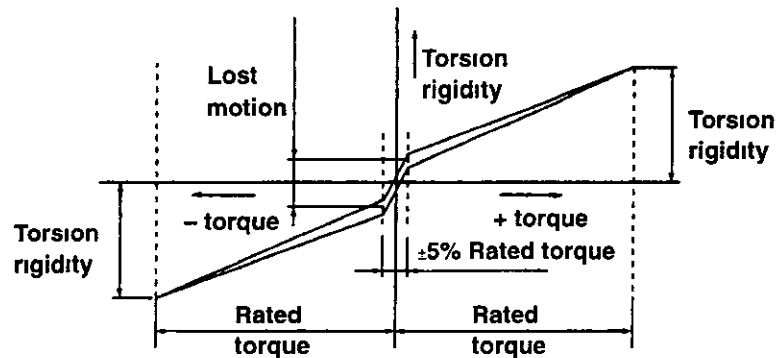

2.1.3 SGMGH Servomotors for 1500 r/min

■ Rating and Specifications for Standard Servomotors Without Gears

- Time Rating Continuous
- Vibration Class 15 μm or below
- Insulation Resistance 500 VDC, 10 M Ω min
- Ambient Temperature 0 to 40°C
- Excitation Permanent magnet
- Mounting Flange method
- Thermal Class F
- Withstand Voltage 1500 VAC for one minute
- Enclosure Totally enclosed, IP67 self-cooled (except through sections of the shaft)
- Ambient Humidity 20% to 80% (with no condensation)
- Drive Method Direct drive

Table 2 11 SGMGH Standard Servomotor Ratings and Specifications

Servomotor Model SGMGH-		05A□ A	09A□ A	13A□ A	20A□ A	30A□ A	44A□ A	55A□ A	75A□ A	1AA- □A	1EA- □A
Rated Output *	kW	0.45	0.85	1.3	1.8	2.9	4.4	5.5	7.5	11	15
Rated Torque *	N·m	2.84	5.39	8.34	11.5	18.6	28.4	35.0	48.0	70.0	95.4
	lb·in	25	48	74	102	165	252	310	425	620	844
Instantaneous Peak Torque *	N·m	8.92	13.8	23.3	28.7	45.1	71.1	87.6	119	175	224
	lb·in	79	122	207	254	400	629	775	1053	1549	1982
Rated Current *	A (rms)	3.8	7.1	10.7	16.7	23.8	32.8	42.1	54.7	58.6	78.0
Instantaneous Max Current *	A (rms)	11	17	28	42	56	84	110	130	140	170
Rated Speed *	r/min	1500									
Max Speed *	r/min	3000								2000	
Torque Constant	N·m/A (rms)	0.82	0.83	0.84	0.73	0.83	0.91	0.88	0.93	1.25	1.32
	lb·in/A (rms)	7.26	7.35	7.43	6.46	7.35	8.05	7.79	8.23	11.1	11.7
Moment of Inertia J	$\times 10^{-4}$ kg·m ²	7.24	13.9	20.5	31.7	46.0	67.5	89.0	125	281	315
	$\times 10^{-3}$ lb·in·s ²	6.42	12.3	18.2	28.0	40.7	59.8	78.8	111	249	279
Rated Power Rate *	kW/s	11.2	20.9	33.8	41.5	75.3	120	137	184	174	289
Rated Angular Acceleration *	rad/s ²	3930	3880	4060	3620	4050	4210	3930	3850	2490	3030
Moment of Inertia Time Constant	ms	5.0	3.1	2.8	2.1	1.9	1.3	1.3	1.1	1.2	0.98
Inductive Time Constant	ms	5.1	5.3	6.3	12.5	12.5	15.7	16.4	18.4	22.6	27.2

* These items and torque-motor speed characteristics quoted in combination with an SGDM Servopack are at an armature winding temperature of 20°C

Note 1. These characteristics are values with the following heat sinks (steel plates) attached for cooling
 400 × 400 × 20 (mm) 05A□A to 13A□A Servomotors
 550 × 550 × 30 (mm) 20A□A to 75A□A Servomotors

Servomotor Ratings and Specifications

2.1.3 SGMGH Servomotors for 1500 r/min

- 2 Add the following numerical values to the moment of inertia in the table for Servomotors fitted with a holding brake
Other specifications will also change slightly

Servomotor Model SGMGH-		05A□A	09A□A	13A□A	20A□A	30A□A	44A□A	55A□A	75A□A
Holding Brake	$\times 10^{-4} \text{ kg m}^2$	2.10			8.50				
	$\times 10^{-3} \text{ lb-in s}^2$	1.86			7.53				

SGMGH Servomotor Torque-motor Speed Characteristics

The following sections provide the torque-motor speed characteristics of the SGMGH Servomotors at 1500 r/min

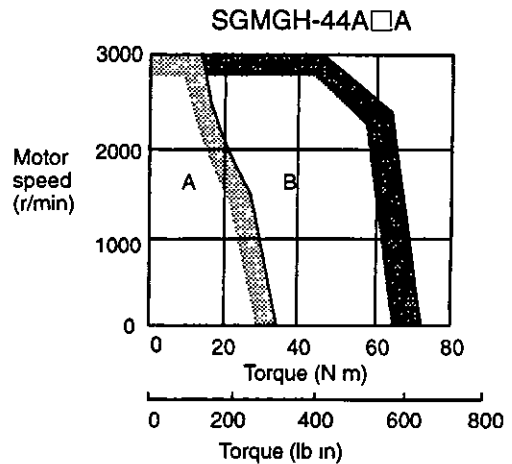
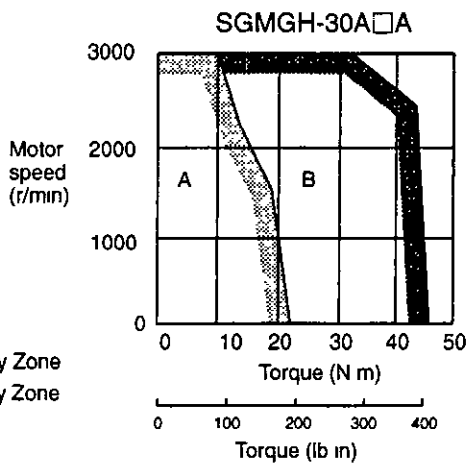
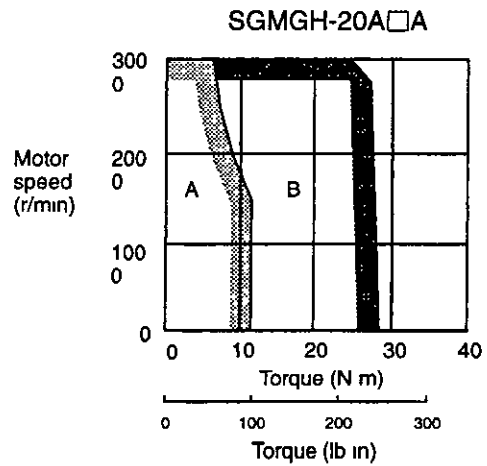
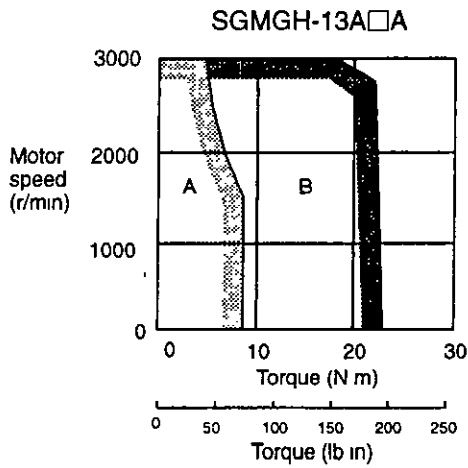
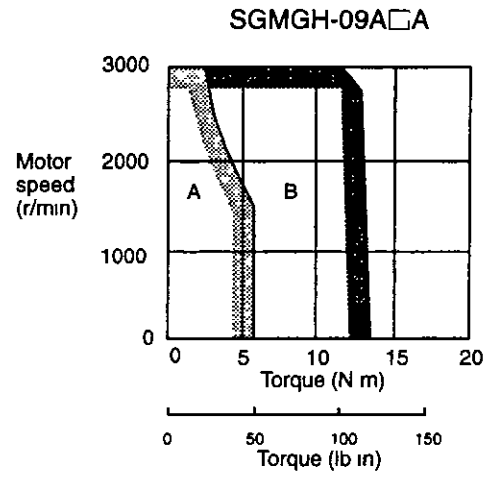
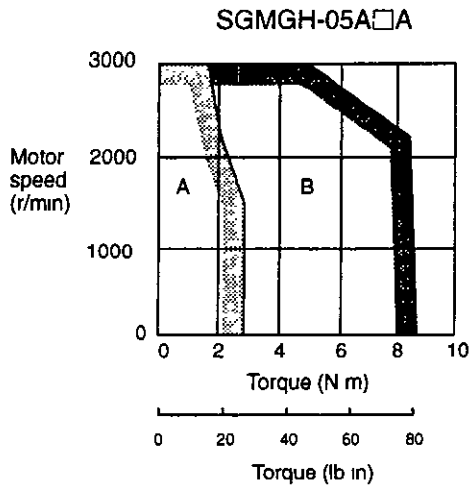

A Continuous Duty Zone
 B Intermittent Duty Zone

Servomotor Ratings and Specifications

2 1 3 SGMGH Servomotors for 1500 r/min

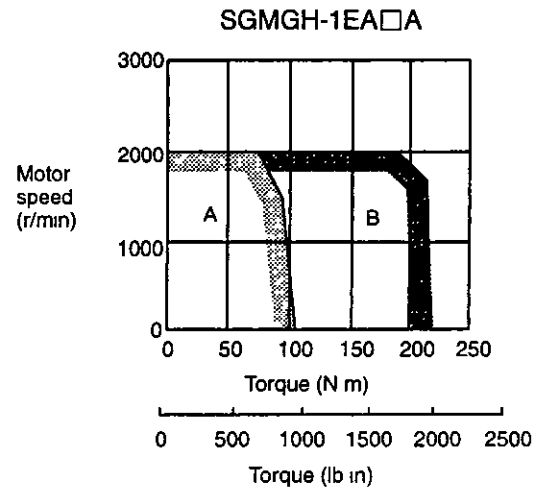
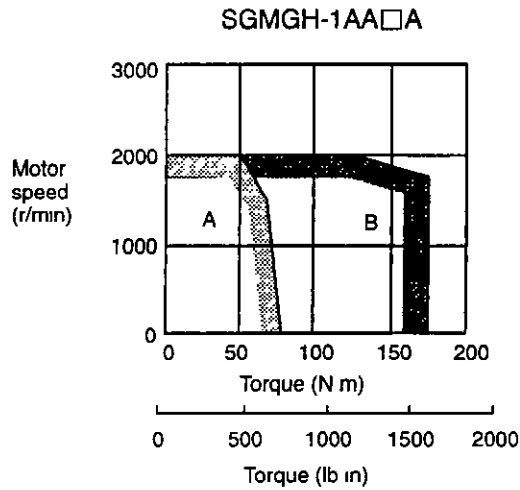
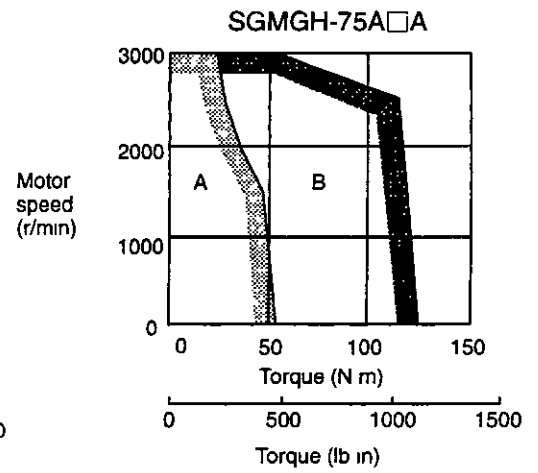
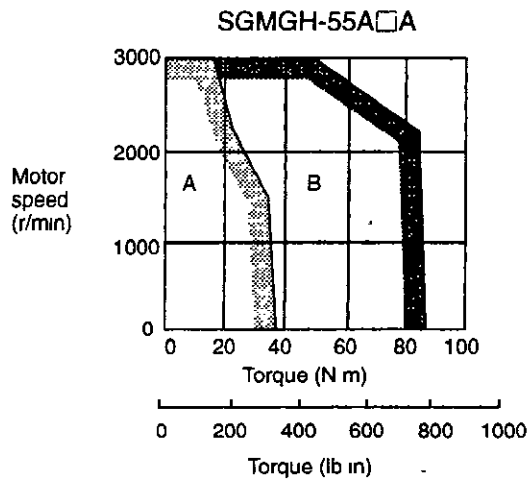

- A Continuous Duty Zone
- B Intermittent Duty Zone

■ Ratings and Specifications for SGMGH Servomotors with Standard Backlash Gears

- Time Rating Continuous
 - Vibration Class 15 μm or below
 - Insulation Resistance 500 VDC, 10 MΩ min
 - Ambient Temperature 0 to 40°C
 - Excitation Permanent magnet
 - Mounting Foot and flange-mounted
 - Type 4095 to 4115 Omni-directional mounting
 - Type 4130 to 4190 Horizontal mounting to shaft
 - Rotation Direction Servomotor rotation direction and reverse direction
 - Gear Lubricating Method
 - Type 4095 to 4115 Grease
 - Type 4130 to 4190 Oil
 - Gear Mechanism Planetary gear mechanism
 - Thermal Class F
 - Withstand Voltage 1500 VAC for one minute
 - Enclosure Totally enclosed, IP44 self-cooled (or the equivalent)
 - Ambient Humidity 20% to 80% (with no condensation)
 - Drive Method Direct drive
 - Backlash Roughly 0.6 to 2° at the gear output shaft
- For oil lubrication, the motor should be mounted horizontal to the shaft. Contact your Yaskawa representative about lubrication for mounting at angles.



Table 2.12 Ratings and Specifications for SGMGH Servomotors with Standard Backlash Gears

Servomotor Model SGMGH-	Servomotor			Gear					Load Moment of Inertia J at the Motor Shaft (Servomotor + Gear) kg m ² (lb in-s ²)	Gear Moment of Inertia J Kg-m ² (lb in-s ²)
	Output kW	Rated Speed r/min	Rated Torque N m (lb-in)	Gear Ratio	Rated Torque/Efficiency N m/% (lb in/%)	Instantaneous Peak Torque/Efficiency N m/% (lb in/%)	Rated Speed r/min	Max. Speed r/min		
-05A□A□A6	0.45	1500	2.84 (25)	1/6	13.6/80 (120/80)	42.8/80 (379/80)	250	500	9.20 × 10 ⁻⁴ (8.14 × 10 ⁻³)	1.96 × 10 ⁻⁴ (1.73 × 10 ⁻³)
-05A□A□B6				1/11	25.0/80 (221/80)	78.5/80 (695/80)	136	272	8.84 × 10 ⁻⁴ (7.82 × 10 ⁻³)	1.6 × 10 ⁻⁴ (1.42 × 10 ⁻³)
-05A□A□C6				1/21	44.8/70 (397/70)	140/75 (1239/75)	71	142	8.39 × 10 ⁻⁴ (7.43 × 10 ⁻³)	1.15 × 10 ⁻⁴ (1.02 × 10 ⁻³)
-05A□A□76				1/29	66.0/80 (584/80)	207/80 (1832/80)	51	103	8.41 × 10 ⁻⁴ (7.44 × 10 ⁻³)	1.17 × 10 ⁻⁴ (1.04 × 10 ⁻³)
-09A□A□A6	0.85	1500	5.39 (48)	1/6	25.9/80 (229/80)	66.3/80 (587/80)	250	500	15.7 × 10 ⁻⁴ (13.9 × 10 ⁻³)	1.8 × 10 ⁻⁴ (1.59 × 10 ⁻³)
-09A□A□B6				1/11	47.4/80 (420/80)	122/80 (1080/80)	136	272	15.3 × 10 ⁻⁴ (13.5 × 10 ⁻³)	1.4 × 10 ⁻⁴ (1.24 × 10 ⁻³)
-09A□A□C6				1/21	79.3/70 (702/70)	203/70 (1797/70)	71	142	15.9 × 10 ⁻⁴ (14.1 × 10 ⁻³)	2.0 × 10 ⁻⁴ (1.77 × 10 ⁻³)
-09A□A□76				1/29	125/75 (1106/75)	321/80 (2841/80)	51	103	16.1 × 10 ⁻⁴ (14.3 × 10 ⁻³)	2.2 × 10 ⁻⁴ (1.95 × 10 ⁻³)
-13A□A□A6	1.3	1500	8.34 (74)	1/6	40.0/80 (354/80)	112/80 (991/80)	250	500	22.3 × 10 ⁻⁴ (19.7 × 10 ⁻³)	1.8 × 10 ⁻⁴ (1.59 × 10 ⁻³)

Servomotor Ratings and Specifications

2 1 3 SGMGH Servomotors for 1500 r/min

Servomotor Model SGMGH-	Servomotor			Gear					Load Moment of Inertia J at the Motor Shaft (Servomotor + Gear) kg m ² (lb in s ²)	Gear Moment of Inertia J Kg m ² (lb-in s ²)
	Output kW	Rated Speed r/min	Rated Torque N m (lb-in)	Gear Ratio	Rated Torque/Efficiency N m/% (lb in/%)	Instantaneous Peak Torque/Efficiency N m/% (lb in/%)	Rated Speed r/min	Max. Speed r/min		
-13A□A□B6	1.3	1500	8.34 (74)	1/11	68.7/80 (608/80)	192/75 (1699/75)	136	272	23.4 × 10 ⁻⁴ (20.7 × 10 ⁻³)	2.9 × 10 ⁻⁴ (2.57 × 10 ⁻³)
-13A□A□C6				1/21	140/75 (1239/75)	392/80 (3470/80)	71	142	22.5 × 10 ⁻⁴ (19.9 × 10 ⁻³)	2.0 × 10 ⁻⁴ (1.77 × 10 ⁻³)
-13A□A□76				1/29	193/80 (1708/80)	541/80 (4788/80)	51	103	21.4 × 10 ⁻⁴ (18.9 × 10 ⁻³)	0.9 × 10 ⁻⁴ (0.797 × 10 ⁻³)
-20A□A□A6	1.8	1500	11.5 (102)	1/6	55.1/80 (488/80)	138/80 (1221/80)	250	500	38.0 × 10 ⁻⁴ (33.6 × 10 ⁻³)	6.3 × 10 ⁻⁴ (5.58 × 10 ⁻³)
-20A□A□B6				1/11	101/80 (894/80)	253/80 (2239/80)	136	272	36.5 × 10 ⁻⁴ (32.3 × 10 ⁻³)	4.8 × 10 ⁻⁴ (4.25 × 10 ⁻³)
-20A□A□C6				1/21	193/75 (1708/75)	482/80 (4266/80)	71	142	37.6 × 10 ⁻⁴ (33.3 × 10 ⁻³)	5.9 × 10 ⁻⁴ (5.22 × 10 ⁻³)
-20A□A□76				1/29	266/80 (2354/80)	666/80 (5895/80)	51	103	37.3 × 10 ⁻⁴ (33.0 × 10 ⁻³)	5.6 × 10 ⁻⁴ (4.96 × 10 ⁻³)
-30A□A□A6	2.9	1500	18.6 (165)	1/6	89.4/80 (791/80)	217/80 (1921/80)	250	500	52.3 × 10 ⁻⁴ (46.3 × 10 ⁻³)	6.3 × 10 ⁻⁴ (5.58 × 10 ⁻³)
-30A□A□B6				1/11	164/80 (1452/80)	397/80 (3514/80)	136	272	50.8 × 10 ⁻⁴ (45.0 × 10 ⁻³)	4.8 × 10 ⁻⁴ (4.25 × 10 ⁻³)
-30A□A□C6				1/21	313/80 (2770/80)	758/80 (6709/80)	71	142	51.9 × 10 ⁻⁴ (45.9 × 10 ⁻³)	5.9 × 10 ⁻⁴ (5.22 × 10 ⁻³)
-30A□A□76				1/29	432/75 (3824/75)	1049/80 (9285/80)	51	103	91.9 × 10 ⁻⁴ (81.3 × 10 ⁻³)	45.9 × 10 ⁻⁴ (40.6 × 10 ⁻³)
-44A□A□A6	4.4	1500	28.4 (251)	1/6	136/80 (1204/80)	341/80 (3018/80)	250	500	79.5 × 10 ⁻⁴ (70.4 × 10 ⁻³)	12.0 × 10 ⁻⁴ (10.6 × 10 ⁻³)
-44A□A□B6				1/11	250/80 (2213/80)	625/80 (5532/80)	136	272	75.2 × 10 ⁻⁴ (66.6 × 10 ⁻³)	7.7 × 10 ⁻⁴ (6.82 × 10 ⁻³)
-44A□A□C6				1/21	477/80 (4222/80)	1196/80 (10586/80)	71	142	115 × 10 ⁻⁴ (102 × 10 ⁻³)	47.5 × 10 ⁻⁴ (42.0 × 10 ⁻³)
-44A□A□76				1/29	660/80 (5842/80)	1646/80 (14569/80)	51	103	131 × 10 ⁻⁴ (116 × 10 ⁻³)	63.5 × 10 ⁻⁴ (56.2 × 10 ⁻³)
-55A□A□A6	5.5	1500	35.0 (310)	1/6	168/80 (1487/80)	420/80 (3717/80)	250	500	103 × 10 ⁻⁴ (91.2 × 10 ⁻³)	14.0 × 10 ⁻⁴ (12.4 × 10 ⁻³)
-55A□A□B6				1/11	308/80 (2726/80)	771/80 (6824)	136	272	98.8 × 10 ⁻⁴ (87.4 × 10 ⁻³)	9.8 × 10 ⁻⁴ (8.67 × 10 ⁻³)
-55A□A□C6				1/21	588/80 (5204/80)	1470/80 (13011/80)	71	142	168 × 10 ⁻⁴ (149 × 10 ⁻³)	79.0 × 10 ⁻⁴ (69.9 × 10 ⁻³)
-55A□A□76				1/29	811/80 (7178/80)	2029/80 (17959/80)	51	103	166 × 10 ⁻⁴ (147 × 10 ⁻³)	77.0 × 10 ⁻⁴ (68.2 × 10 ⁻³)
-75A□A□B6	7.5	1500	48.0 (425)	1/11	422/80 (3735/80)	1039/80 (9196/80)	136	272	190 × 10 ⁻⁴ (168 × 10 ⁻³)	65.0 × 10 ⁻⁴ (57.5 × 10 ⁻³)
-75A□A□C6				1/21	807/80 (7143/80)	1989/80 (17605/80)	71	142	204 × 10 ⁻⁴ (181 × 10 ⁻³)	79.0 × 10 ⁻⁴ (69.9 × 10 ⁻³)
-75A□A□76				1/29	1117/80 (9887/80)	2754/80 (24376/80)	51	103	216 × 10 ⁻⁴ (191 × 10 ⁻³)	91.0 × 10 ⁻⁴ (80.5 × 10 ⁻³)

Note Output torque and motor speed produce the following trends in efficiency Values in the table are at the rated motor speed

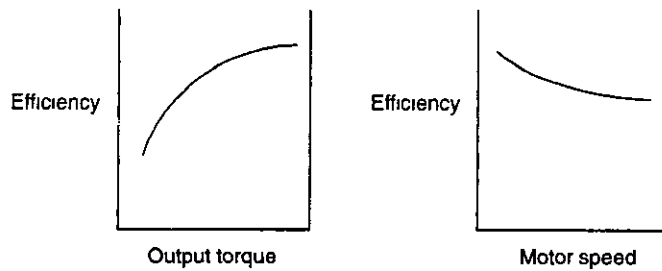

Configuration

The following configuration accurately and efficiently transmits Servomotor power

A gear (Cyclo) is used in combination with the internal planetary gear mechanism of the Servomotor

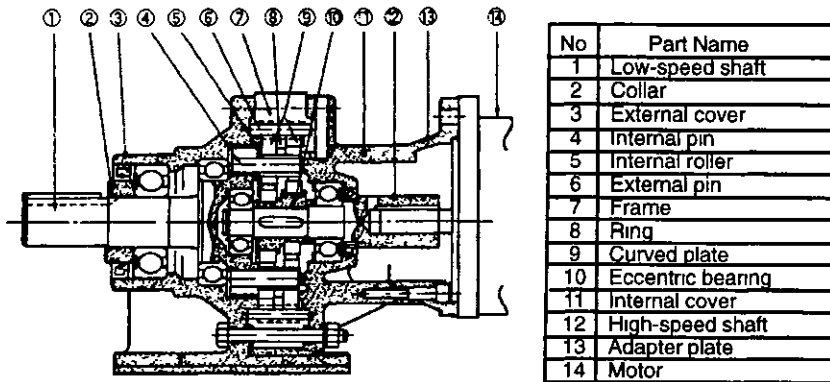

Gear Lubrication

- **Grease Lubricating Type (4095 to 4115)**

The gearbox is filled at the factory

- **Oil Lubricating Type (4130 to 4190)**

All oil is drained from the gears prior to shipment The gearbox must be filled to the red line at the top of the oil gauge before initial use

We recommend using industrial extreme-pressure gear oil or SP type or JIS K 2219 industrial gear oil type 2 or equivalent See the following table

Ambient Temperature C° (F°)	Manufacturer		
	Kosmo Oil Co., Ltd	Nihon Sekiyu Co , Ltd.	General Oil Co. Ltd.
0 to 35°C (32° to 95°F)	Kosmo Gear Co , Ltd SE 100, 150	Bonokku M 100, 150	General SP Gear Roll 100, 150

Approximate amounts of oil are shown in the following table

(Unit: l [liters])

Frame No.	4130 4135	4145	4155	4160 4165	4170 4175	4180 4185	4190
Horizontal Type	0.7	0.7	0.7	1.4	1.9	2.5	4.0

■ Ratings and Specifications for SGMGH Servomotors with Low-backlash Gears

- Time Rating: Continuous
- Vibration Class: 15 μ m or below
- Insulation Resistance: 500 VDC, 10 M Ω min
- Ambient Temperature: 0 to 40°C
- Excitation: Permanent magnet
- Mounting: Flange method (can be mounted in any direction)
- Rotation Direction: Servomotor rotation direction
- Gear Mechanism: Planetary gear mechanism
- Thermal Class: F
- Withstand Voltage: 1500 VAC for one minute
- Enclosure: Totally enclosed, IP44 self-cooled (or the equivalent)
- Ambient Humidity: 20% to 80% (with no condensation)
- Drive Method: Direct drive
- Gear Lubricating Method: Grease
- Backlash: 0.05° (3 min) at the gear output shaft

Table 2.13 Ratings and Specifications for SGMGH Servomotors with Low-backlash Gears

Servomotor Model SGMGH-	Servomotor			Gear					Load Moment of Inertia J at the Motor Shaft (Servomotor + Gear) kg m ² (lb in s ²)	Gear Moment of Inertia J kg m ² (lb·in·s ²)
	Output kW	Rated Speed r/min	Rated Torque N m (lb·in)	Gear Ratio	Rated Torque/Efficiency N m/% (lb in/%)	Instantaneous Peak Torque/Efficiency N m/% (lb in/%)	Rated Speed r/min	Max. Speed r/min		
-05A□AL14	0.45	1500	2.84 (25)	1/5	11.4/80 (101/80)	35.7/80 (316/80)	300	600	8.50 × 10 ⁻⁴ (7.52 × 10 ⁻³)	1.26 × 10 ⁻⁴ (1.12 × 10 ⁻³)
-05A□AL24				1/9	20.4/80 (181/80)	64.2/80 (568/80)	167	334	8.18 × 10 ⁻⁴ (7.24 × 10 ⁻³)	0.94 × 10 ⁻⁴ (0.832 × 10 ⁻³)
-05A□AL54				1/20	45.4/80 (402/80)	143/80 (1266/80)	75	150	11.9 × 10 ⁻⁴ (10.5 × 10 ⁻³)	4.66 × 10 ⁻⁴ (4.12 × 10 ⁻³)
-05A□AL74				1/29	65.9/80 (583/80)	207/80 (1832/80)	51	102	10.0 × 10 ⁻⁴ (8.85 × 10 ⁻³)	2.76 × 10 ⁻⁴ (2.44 × 10 ⁻³)
-05A□AL84				1/45	102/80 (903/80)	321/80 (2841/80)	33	66	9.05 × 10 ⁻⁴ (8.01 × 10 ⁻³)	1.81 × 10 ⁻⁴ (1.60 × 10 ⁻³)
-09A□AL14	0.85	1500	5.39 (48)	1/5	21.6/80 (191/80)	55.2/80 (489/80)	300	600	15.2 × 10 ⁻⁴ (13.5 × 10 ⁻³)	1.30 × 10 ⁻⁴ (1.15 × 10 ⁻³)
-09A□AL24				1/9	38.8/80 (343/80)	74.5/60 (659/60)	167	334	14.8 × 10 ⁻⁴ (13.1 × 10 ⁻³)	0.90 × 10 ⁻⁴ (0.797 × 10 ⁻³)
-09A□AL54				1/20	86.2/80 (763/80)	221/80 (1956/80)	75	150	18.6 × 10 ⁻⁴ (16.5 × 10 ⁻³)	4.70 × 10 ⁻⁴ (4.16 × 10 ⁻³)
-09A□AL74				1/29	125/80 (1106/80)	320/80 (2832/80)	51	102	16.7 × 10 ⁻⁴ (14.8 × 10 ⁻³)	2.80 × 10 ⁻⁴ (2.48 × 10 ⁻³)
-09A□AL84				1/45	194/80 (1717/80)	497/80 (4399/80)	33	66	18.4 × 10 ⁻⁴ (16.3 × 10 ⁻³)	4.50 × 10 ⁻⁴ (3.98 × 10 ⁻³)
-13A□AL14	1.3	1500	8.34 (74)	1/5	33.4/80 (296/80)	93.2/80 (825/80)	300	600	27.7 × 10 ⁻⁴ (24.5 × 10 ⁻³)	7.20 × 10 ⁻⁴ (6.37 × 10 ⁻³)
-13A□AL24				1/9	60.0/80 (531/80)	168/80 (1487/80)	167	334	25.3 × 10 ⁻⁴ (22.4 × 10 ⁻³)	4.80 × 10 ⁻⁴ (4.25 × 10 ⁻³)
-13A□AL54				1/20	133/80 (1177/80)	373/80 (3301/80)	75	150	27.4 × 10 ⁻⁴ (24.3 × 10 ⁻³)	6.90 × 10 ⁻⁴ (6.11 × 10 ⁻³)
-13A□AL74				1/29	193/80 (1708/80)	541/80 (4788/80)	51	102	30.9 × 10 ⁻⁴ (27.3 × 10 ⁻³)	10.4 × 10 ⁻⁴ (9.21 × 10 ⁻³)
-13A□AL84				1/45	300/80 (2655/80)	839/80 (7426/80)	33	66	27.2 × 10 ⁻⁴ (24.1 × 10 ⁻³)	6.70 × 10 ⁻⁴ (5.93 × 10 ⁻³)



Servomotor Ratings and Specifications

2 1 3 SGMGH Servomotors for 1500 r/min

Servomotor Model SGMGH-	Servomotor			Gear					Load Moment of Inertia J at the Motor Shaft (Servomotor + Gear) kg·m ² (lb·in·s ²)	Gear Moment of Inertia J kg·m ² (lb·in·s ²)
	Output kW	Rated Speed r/min	Rated Torque N·m (lb·in)	Gear Ratio	Rated Torque/Efficiency N m/% (lb in/%)	Instantaneous Peak Torque/Efficiency N m/% (lb in/%)	Rated Speed r/min	Max. Speed r/min		
-20A□AL14	1.8	1500	11.5 (102)	1/5	46.0/80 (407/80)	115/80 (1018/80)	300	600	41.9 × 10 ⁻⁴ (37.1 × 10 ⁻³)	10.2 × 10 ⁻⁴ (9.03 × 10 ⁻³)
-20A□AL24				1/9	82.8/80 (733/80)	207/80 (1832/80)	167	334	39.5 × 10 ⁻⁴ (35.0 × 10 ⁻³)	7.8 × 10 ⁻⁴ (6.90 × 10 ⁻³)
-20A□AL54				1/20	184/80 (1629/80)	459/80 (4063/80)	75	150	51.9 × 10 ⁻⁴ (45.9 × 10 ⁻³)	20.2 × 10 ⁻⁴ (17.9 × 10 ⁻³)
-20A□AL74				1/29	267/80 (2363/80)	666/80 (5895/80)	51	102	45.1 × 10 ⁻⁴ (39.9 × 10 ⁻³)	13.4 × 10 ⁻⁴ (11.9 × 10 ⁻³)
-30A□AL14	2.9	1500	18.6 (165)	1/5	74.4/80 (659/80)	182/80 (1611/80)	300	600	66.4 × 10 ⁻⁴ (58.8 × 10 ⁻³)	20.4 × 10 ⁻⁴ (18.1 × 10 ⁻³)
-30A□AL24				1/9	134/80 (1186/80)	328/80 (2903/80)	167	334	58.5 × 10 ⁻⁴ (51.8 × 10 ⁻³)	12.5 × 10 ⁻⁴ (11.1 × 10 ⁻³)
-30A□AL54				1/20	298/80 (2638/80)	730/80 (6461/80)	75	150	66.2 × 10 ⁻⁴ (58.6 × 10 ⁻³)	20.2 × 10 ⁻⁴ (17.9 × 10 ⁻³)
-44A□AL14	4.4	1500	28.4 (251)	1/5	114/80 (1009/80)	284/80 (2514/80)	300	600	87.9 × 10 ⁻⁴ (77.8 × 10 ⁻³)	20.4 × 10 ⁻⁴ (18.1 × 10 ⁻³)
-44A□AL24				1/9	204/80 (1806/80)	512/80 (4532/80)	167	334	80.0 × 10 ⁻⁴ (70.8 × 10 ⁻³)	12.5 × 10 ⁻⁴ (11.1 × 10 ⁻³)

Note Output torque and motor speed produce the following trends in efficiency. Values in the table are at the rated motor speed.

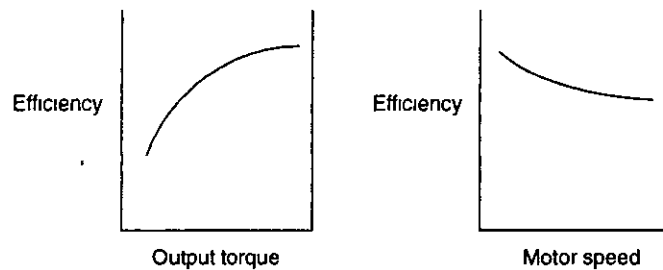

Configuration

This simple planetary gear mechanism is equipped with four planetary gears to which load is evenly distributed via a floating relay ring in each step.

Two gears are used to transmit driving force during forward rotation, and the other two are used to transmit driving force during reverse rotation.

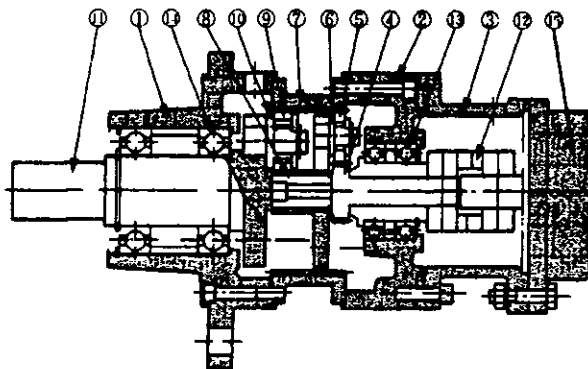

No	Part Name
1	Casing
2	Bracket
3	Motor bracket
4	Primary sun gear
5	Primary planetary gear
6	Primary planetary shaft
7	Internal gear
8	Secondary sun gear
9	Secondary planetary gear
10	Secondary planetary shaft
11	Low-speed shaft
12	Oldham's coupling
13	High-speed shaft bearing
14	Low-speed shaft bearing
15	Motor

Gear Lubrication

The gearbox is filled at the factory.

2.1.4 SGMGH Servomotors for 1000 r/min

■ Rating and Specifications for Standard Servomotors Without Gears

- Time Rating Continuous
- Vibration Class 15 μm or below
- Insulation Resistance 500 VDC, 10 M Ω min
- Ambient Temperature 0 to 40°C
- Excitation Permanent magnet
- Mounting Flange method
- Thermal Class F
- Withstand Voltage 1500 VAC for one minute
- Enclosure Totally enclosed, IP67 self-cooled (except through sections of the shaft)
- Ambient Humidity 20% to 80% (with no condensation)
- Drive Method Direct drive

Servomotor Ratings and Specifications

2 1 4 SGMGH Servomotors for 1000 r/min

Table 2 14 SGMGH Standard Servomotor Ratings and Specifications

Servomotor Model SGMGH-		03A□B	06A□B	09A□B	12A□B	20A□B	30A□B	40A□B	55A□B
Rated Output *	kW	0.3	0.6	0.9	1.2	2.0	3.0	4.0	5.5
Rated Torque *	N m	2.84	5.68	8.62	11.5	19.1	28.4	38.2	52.6
	lb in	25	50	76	102	169	251	338	465
Instantaneous Peak Torque *	N m	7.17	14.1	19.3	28.0	44.0	63.7	107	136.9
	lb in	63	125	171	248	389	564	947	1211
Rated Current *	A (rms)	3.0	5.7	7.6	11.6	18.5	24.8	30	43.2
Instantaneous Max. Current *	A (rms)	7.3	13.9	16.6	28	42	56	84	110
Rated Speed *	r/min	1000							
Max. Speed *	r/min	2000							
Torque Constant	N m/A (rms)	1.03	1.06	1.21	1.03	1.07	1.19	1.34	1.26
	lb-in/A (rms)	9.12	9.38	10.7	9.12	9.47	10.5	11.9	11.2
Moment of Inertia J	$\times 10^{-4}$ kg m ²	7.24	13.9	20.5	31.7	46.0	67.5	89.0	125
	$\times 10^{-3}$ lb-in s ²	6.41	12.3	18.1	28.1	40.7	59.7	78.8	111
Rated Power Rate *	kW/s	11.2	23.2	36.3	41.5	79.4	120	164	221
Rated Angular Acceleration *	rad/s ²	3930	4080	4210	3620	4150	4210	4290	4200
Moment of Inertia Time Constant	ms	5.1	3.8	2.8	2.0	1.7	1.4	1.3	1.1
Inductive Time Constant	ms	5.1	4.7	5.7	13.5	13.9	15.5	14.6	16.5

* These items and torque-motor speed characteristics quoted in combination with an SGDM Servopack are at an armature winding temperature of 20°C

- Note 1 These characteristics are values with the following heat sinks (steel plates) attached for cooling
 400 × 400 × 20 (mm) 03A□B to 09A□B Servomotors
 550 × 550 × 30 (mm) 12A□B to 60A□B Servomotors

2 Add the numerical values given below to the moment of inertia in the table for Servomotors fitted with a holding brake
 Other specifications will also change slightly

Servomotor Model SGMGH-		03A□B	06A□B	09A□B	12A□B	20A□B	30A□B	40A□B	55A□B
Holding Brake	$\times 10^{-4}$ kg m ²	2.10			8.50				
	$\times 10^{-3}$ lb-in s ²	1.86			7.52				

SGMGH Servomotor Torque-motor Speed Characteristics

The following sections provide the torque-motor speed characteristics of the SGMGH Servomotors at 1000 r/min

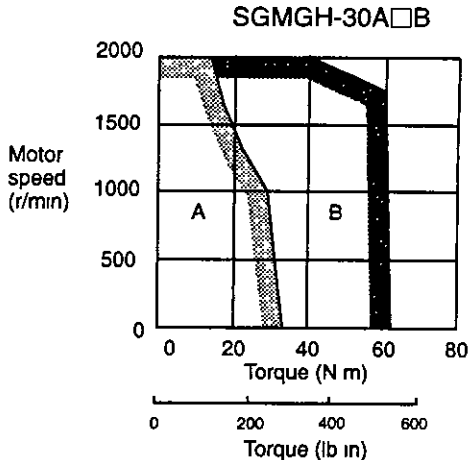
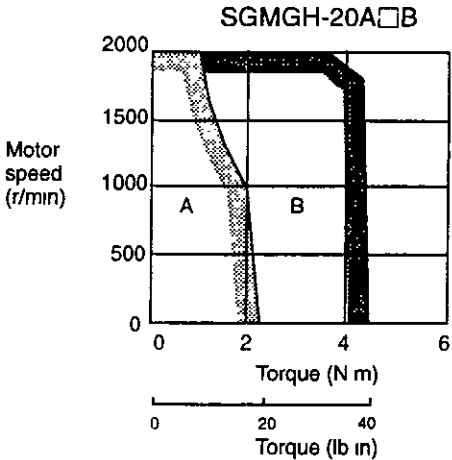
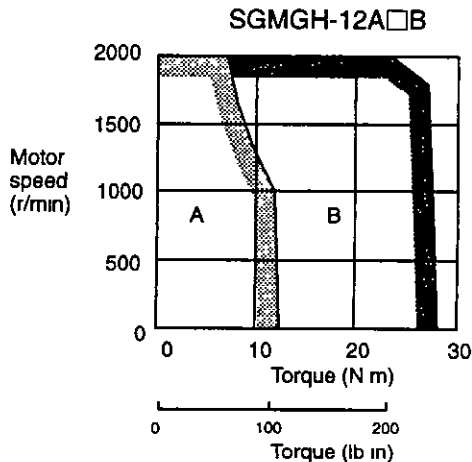
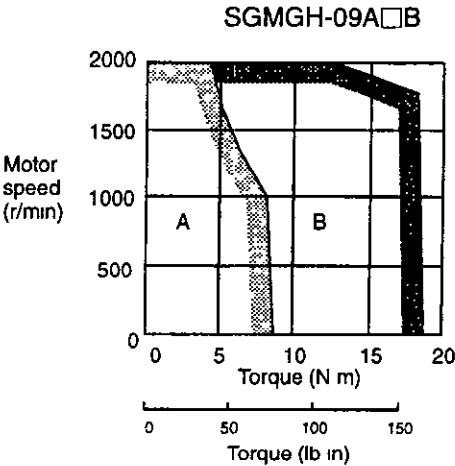
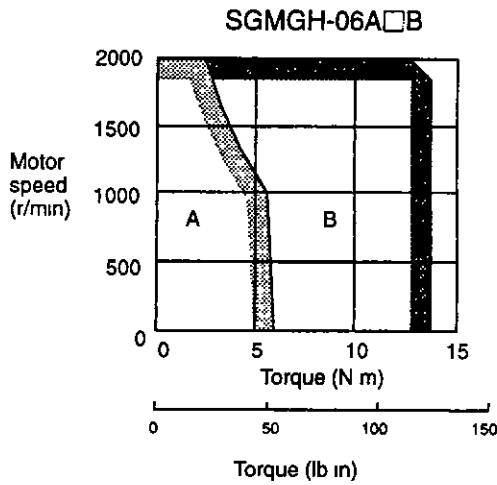
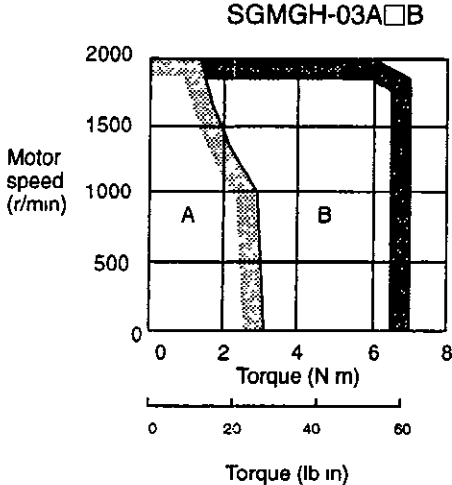

A Continuous Duty Zone
 B Intermittent Duty Zone

Servomotor Ratings and Specifications

2.1.4 SGMGH Servomotors for 1000 r/min

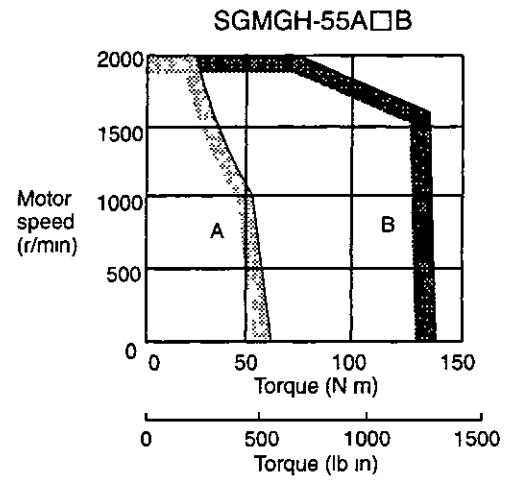
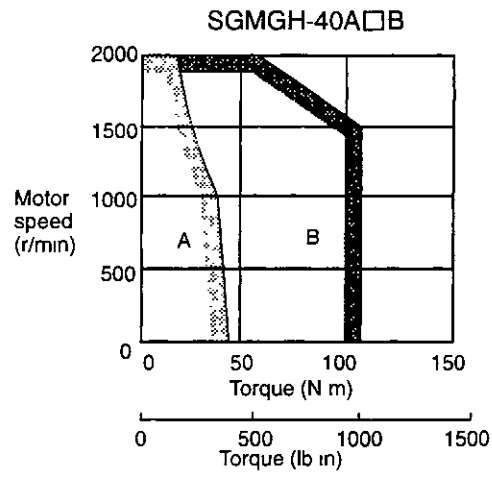

- A Continuous Duty Zone
- B Intermittent Duty Zone

■ Ratings and Specifications for SGMGH Servomotors with Standard Backlash Gears

- Time Rating Continuous
 - Vibration Class 15 μm or below
 - Insulation Resistance 500 VDC, 10 M Ω min
 - Ambient Temperature 0 to 40°C
 - Thermal Class F
 - Withstand Voltage 1500 VAC for one minute
 - Enclosure Totally enclosed, IP44 self-cooled (or the equivalent)
 - Ambient Humidity 20% to 80% (with no condensation)
 - Drive Method Direct drive
 - Excitation Permanent magnet
 - Mounting Foot and flange-mounted
 - Type 4095 to 4115 Omni-directional mounting
 - Type 4130 to 4190 Horizontal mounting to shaft
 - Rotation Direction Servomotor rotation direction and reverse direction
 - Gear Lubricating Method
 - Type 4095 to 4115 Grease
 - Type 4130 to 4190 Oil
 - Gear Mechanism Planetary gear mechanism
 - Backlash Roughly 0.6 to 2° at gear output shaft
- For oil lubrication, motor should be mounted horizontal to the shaft. Contact your Yaskawa representative about lubrication for angle mounting.

Table 2.15 Ratings and Specifications for SGMGH Servomotors with Standard Backlash Gears

Servomotor Model SGMGH-	Servomotor			Gear					Load Moment of Inertia J at the Motor Shaft (Servomotor + Gear) kg m^2 (lb-in-s ²)	Gear Moment of Inertia J Kg m^2 (lb in-s ²)
	Output kW	Rated Speed r/min	Rated Torque N·m (lb in)	Gear Ratio	Rated Torque/Efficiency N m/% (lb in/%)	Instantaneous Peak Torque/Efficiency N m/% (lb in/%)	Rated Speed r/min	Max Speed r/min		
-03A□B□A6	0.3	1000	2.84 (25)	1/6	13.6/80 (120/80)	34.4/80 (304/80)	166	333	9.20×10^{-4} (8.14×10^{-3})	1.96×10^{-4} (1.73×10^{-3})
-03A□B□B6				1/11	25.0/80 (221/80)	63.1/80 (558/80)	90	181	8.84×10^{-4} (7.82×10^{-3})	1.6×10^{-4} (1.42×10^{-3})
-03A□B□C6				1/21	41.8/70 (370/70)	106/70 (938/70)	47	95	8.39×10^{-4} (7.43×10^{-3})	1.15×10^{-4} (1.02×10^{-3})
-03A□B□76				1/29	65.9/80 (583/80)	167/80 (1478/80)	34	68	8.41×10^{-4} (7.44×10^{-3})	1.17×10^{-4} (1.04×10^{-3})
-06A□B□A6	0.6		5.68 (50)	1/6	27.2/80 (241/80)	67.7/80 (599/80)	166	333	15.7×10^{-4} (13.9×10^{-3})	1.8×10^{-4} (1.59×10^{-3})
-06A□B□B6				1/11	50.0/80 (443/80)	125/80 (1106/80)	90	181	15.3×10^{-4} (13.5×10^{-3})	1.4×10^{-4} (1.24×10^{-3})
-06A□B□C6				1/21	83.5/70 (739/70)	208/70 (1841/70)	47	95	15.9×10^{-4} (14.1×10^{-3})	2.0×10^{-4} (1.77×10^{-3})
-06A□B□76				1/29	123/75 (1089/75)	307/75 (2717/75)	34	68	16.1×10^{-4} (14.3×10^{-3})	2.2×10^{-4} (1.95×10^{-3})
-09A□B□A6	0.9		8.62 (76)	1/6	41.4/80 (366/80)	92.7/80 (820/80)	166	333	22.3×10^{-4} (19.7×10^{-3})	1.8×10^{-4} (1.59×10^{-3})
-09A□B□B6				1/11	75.9/80 (672/80)	170/80 (1505/80)	90	181	21.9×10^{-4} (19.4×10^{-3})	1.4×10^{-4} (1.24×10^{-3})

Servomotor Ratings and Specifications

2 1 4 SGMGH Servomotors for 1000 r/min

Servomotor Model SGMGH-	Servomotor			Gear					Load Moment of Inertia J at the Motor Shaft (Servomotor + Gear) kg m ² (lb in s ²)	Gear Moment of Inertia J Kg·m ² (lb·in·s ²)
	Output kW	Rated Speed r/min	Rated Torque N m (lb in)	Gear Ratio	Rated Torque/Efficiency N m/% (lb in/%)	Instantaneous Peak Torque/Efficiency N m/% (lb in/%)	Rated Speed r/min	Max. Speed r/min		
-09A□B□C6	0.9	1000	8.62 (76)	1/21	136/75 (1204/75)	304/75 (2691/75)	47	95	22.5 × 10 ⁻⁴ (19.9 × 10 ⁻³)	2.0 × 10 ⁻⁴ (1.77 × 10 ⁻³)
-09A□B□76				1/29	200/80 (1770/80)	448/80 (3965/80)	34	68	22.8 × 10 ⁻⁴ (20.2 × 10 ⁻³)	2.3 × 10 ⁻⁴ (2.04 × 10 ⁻³)
-12A□B□A6	1.2	1000	11.5 (102)	1/6	55.0/80 (487/80)	126/75 (1115/75)	166	333	38.0 × 10 ⁻⁴ (33.6 × 10 ⁻³)	6.3 × 10 ⁻⁴ (5.58 × 10 ⁻³)
-12A□B□B6				1/11	101/80 (894/80)	247/80 (2186/80)	90	181	36.5 × 10 ⁻⁴ (32.3 × 10 ⁻³)	4.8 × 10 ⁻⁴ (4.25 × 10 ⁻³)
-12A□B□C6				1/21	180/75 (1593/75)	441/75 (3903/75)	47	95	37.6 × 10 ⁻⁴ (33.3 × 10 ⁻³)	5.9 × 10 ⁻⁴ (5.22 × 10 ⁻³)
-12A□B□76				1/29	266/80 (2354/80)	651/80 (5762/80)	34	68	37.3 × 10 ⁻⁴ (33.0 × 10 ⁻³)	5.6 × 10 ⁻⁴ (4.96 × 10 ⁻³)
-20A□B□A6	2.0	1000	19.1 (169)	1/6	91.7/80 (812/80)	212/80 (1876/80)	166	333	52.3 × 10 ⁻⁴ (46.3 × 10 ⁻³)	6.3 × 10 ⁻⁴ (5.58 × 10 ⁻³)
-20A□B□B6				1/11	169/80 (1496/80)	387/80 (3425/80)	90	181	50.8 × 10 ⁻⁴ (45.0 × 10 ⁻³)	4.8 × 10 ⁻⁴ (4.25 × 10 ⁻³)
-20A□B□C6				1/21	321/80 (2841/80)	739/80 (6541/80)	47	95	51.9 × 10 ⁻⁴ (45.9 × 10 ⁻³)	5.9 × 10 ⁻⁴ (5.22 × 10 ⁻³)
-20A□B□76				1/29	416/75 (3682/75)	958/75 (8479/75)	34	68	91.9 × 10 ⁻⁴ (81.3 × 10 ⁻³)	45.9 × 10 ⁻⁴ (40.6 × 10 ⁻³)
-30A□B□A6	3.0	1000	28.4 (251)	1/6	136/80 (1204/80)	306/80 (2708/80)	166	333	79.5 × 10 ⁻⁴ (70.4 × 10 ⁻³)	12.0 × 10 ⁻⁴ (10.6 × 10 ⁻³)
-30A□B□B6				1/11	250/80 (2213/80)	561/80 (4965/80)	90	181	75.2 × 10 ⁻⁴ (66.6 × 10 ⁻³)	7.7 × 10 ⁻⁴ (6.82 × 10 ⁻³)
-30A□B□C6				1/21	477/80 (4222/80)	1068/80 (9453/80)	47	95	115 × 10 ⁻⁴ (102 × 10 ⁻³)	47.5 × 10 ⁻⁴ (42.0 × 10 ⁻³)
-30A□B□76				1/29	660/80 (5842/80)	1480/80 (13099/80)	34	68	131 × 10 ⁻⁴ (116 × 10 ⁻³)	63.5 × 10 ⁻⁴ (56.2 × 10 ⁻³)
-40A□B□A6	4.0	1000	38.2 (338)	1/6	183/80 (1622/80)	453/70 (4010/70)	166	333	103 × 10 ⁻⁴ (91.2 × 10 ⁻³)	14.0 × 10 ⁻⁴ (12.4 × 10 ⁻³)
-40A□B□B6				1/11	336/80 (2974/80)	830/70 (7346/70)	90	181	98.8 × 10 ⁻⁴ (87.4 × 10 ⁻³)	9.8 × 10 ⁻⁴ (8.67 × 10 ⁻³)
-40A□B□C6				1/21	641/80 (5678/80)	1588/70 (14055/70)	47	95	168 × 10 ⁻⁴ (149 × 10 ⁻³)	79.0 × 10 ⁻⁴ (69.9 × 10 ⁻³)
-40A□B□76				1/29	886/80 (7871/80)	2185/70 (19339/70)	34	68	166 × 10 ⁻⁴ (147 × 10 ⁻³)	77.0 × 10 ⁻⁴ (68.2 × 10 ⁻³)
-55A□B□B6	5.5	1000	52.6 (465)	1/11	462/80 (4092/80)	1205/80 (10665/80)	90	181	190 × 10 ⁻⁴ (168 × 10 ⁻³)	65.0 × 10 ⁻⁴ (57.5 × 10 ⁻³)
-55A□B□C6				1/21	883/80 (7812/80)	2300/80 (20357/80)	47	95	204 × 10 ⁻⁴ (181 × 10 ⁻³)	79.0 × 10 ⁻⁴ (69.9 × 10 ⁻³)
-55A□B□76				1/29	1220/80 (10788/80)	3176/80 (28111/80)	34	68	216 × 10 ⁻⁴ (191 × 10 ⁻³)	91.0 × 10 ⁻⁴ (80.5 × 10 ⁻³)

Note Output torque and motor speed produce the following trends in efficiency
 Values in the table are at the rated motor speed

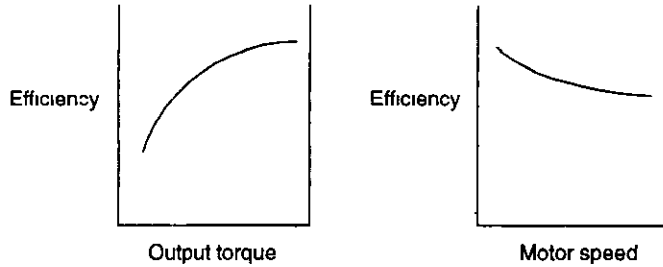

Configuration

This configuration accurately and efficiently transmits Servomotor power

A gear (Cyclo) is used in combination with the internal planetary gear mechanism of the Servomotor

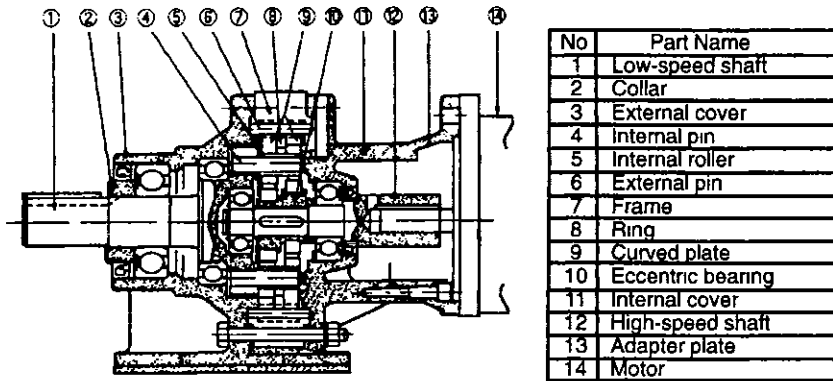

Gear Lubrication

- Grease Lubricating Type (4095 to 4115)

The gearbox is filled at the factory

- Oil Lubricating Type (4130 to 4190)

All oil is drained from the gears prior to shipment. The gearbox must be filled to the red line at the top of the oil gauge before initial use

We recommend using industrial extreme-pressure gear oil or SP type or JIS K 2219 industrial gear oil type 2 or equivalent. See the following table

Ambient Temperature	Manufacturer		
	Kosmo Oil Co., Ltd.	Nihon Sekiyu Co., Ltd.	General Oil Co. Ltd.
0 to 35°C	Kosmo Gear Co., Ltd SE 100, 150	Bonokku M 100, 150	General SP Gear Roll 100, 150

Approximate amounts of oil applied are shown in the following table

(Unit: l [liters])

Frame No	4130 4135	4145	4155	4160 4165	4170 4175	4180 4185	4190
Horizontal Type	0.7	0.7	0.7	1.4	1.9	2.5	4.0

■ Ratings and Specifications for SGMGH Servomotors with Low-backlash Gears

- Time Rating: Continuous
- Vibration Class: 15 μ m or below
- Insulation Resistance: 500 VDC, 10 M Ω min
- Ambient Temperature: 0 to 40°C
- Excitation: Permanent magnet
- Mounting: Flange method (can be mounted in any direction)
- Rotation Direction: Servomotor rotation direction
- Gear Mechanism: Planetary gear mechanism
- Thermal Class: F
- Withstand Voltage: 1500 VAC for one minute
- Enclosure: Totally enclosed, IP44 self-cooled (or the equivalent)
- Ambient Humidity: 20% to 80% (with no condensation)
- Drive Method: Direct drive
- Gear Lubricating Method: Grease
- Backlash: 0.05° (3 min) at the gear output shaft

Table 2.16 Ratings and Specifications for SGMGH Servomotors with Low-backlash Gears

Servomotor Model SGMGH-	Servomotor			Gear					Load Moment of Inertia J at the Motor Shaft (Servomotor + Gear) kg m^2 (lb in-s ²)	Gear Moment of Inertia J kg m^2 (lb in-s ²)
	Output kW	Rated Speed r/min	Rated Torque N·m (lb·in)	Gear Ratio	Rated Torque/Efficiency N m/% (lb in/%)	Instantaneous Peak Torque/Efficiency N m/% (lb in/%)	Rated Speed r/min	Max Speed r/min		
-03A□BL14	0.3	1000	2.84 (25)	1/5	11.4/80 (101/80)	28.7/80 (254/80)	200	400	8.50×10^{-4} (7.52×10^{-3})	1.26×10^{-4} (1.12×10^{-3})
-03A□BL24				1/9	20.4/80 (181/80)	51.6/80 (457/80)	111	222	8.18×10^{-4} (7.24×10^{-3})	0.94×10^{-4} (0.832×10^{-3})
-03A□BL54				1/20	45.4/80 (402/80)	115/80 (1018/80)	50	100	8.64×10^{-4} (7.65×10^{-3})	1.40×10^{-4} (1.24×10^{-3})
-03A□BL74				1/29	65.9/80 (583/80)	166/80 (1469/80)	34	68	10.0×10^{-4} (8.85×10^{-3})	2.76×10^{-4} (2.44×10^{-3})
-03A□BL84				1/45	102/80 (903/80)	258/80 (2284/80)	22	44	9.05×10^{-4} (8.01×10^{-3})	1.81×10^{-4} (1.60×10^{-3})
-06A□BL14	0.6		5.68 (50)	1/5	22.7/80 (201/80)	56.4/80 (499/80)	200	400	15.2×10^{-4} (13.5×10^{-3})	1.30×10^{-4} (1.15×10^{-3})
-06A□BL24				1/9	40.9/80 (362/80)	82.5/80 (730/80)	111	222	14.8×10^{-4} (13.1×10^{-3})	0.90×10^{-4} (0.797×10^{-3})
-06A□BL54				1/20	90.9/80 (805/80)	226/65 (2000/65)	50	100	18.6×10^{-4} (16.5×10^{-3})	4.70×10^{-4} (4.16×10^{-3})
-06A□BL74				1/29	132/80 (1168/80)	327/80 (2894/80)	34	68	16.7×10^{-4} (14.8×10^{-3})	2.80×10^{-4} (2.48×10^{-3})
-06A□BL84				1/45	204/80 (1806/80)	508/80 (4496/80)	22	44	18.4×10^{-4} (16.3×10^{-3})	4.50×10^{-4} (3.98×10^{-3})
-09A□BL14	0.9		8.62 (76)	1/5	34.5/80 (305/80)	77.2/80 (683/80)	200	400	23.9×10^{-4} (21.2×10^{-3})	3.40×10^{-4} (3.01×10^{-3})
-09A□BL24				1/9	62.1/80 (550/80)	139/80 (1230/80)	111	222	25.3×10^{-4} (22.4×10^{-3})	4.80×10^{-4} (4.25×10^{-3})
-09A□BL54				1/20	138/80 (1221/80)	309/80 (2735/80)	50	100	27.4×10^{-4} (24.3×10^{-3})	6.90×10^{-4} (6.11×10^{-3})
-09A□BL74				1/29	200/80 (1770/80)	448/80 (3965/80)	34	68	30.9×10^{-4} (27.3×10^{-3})	10.4×10^{-4} (9.21×10^{-3})
-09A□BL84				1/45	310/80 (2744/80)	695/80 (6151/80)	22	44	27.2×10^{-4} (24.1×10^{-3})	6.70×10^{-4} (5.93×10^{-3})

Servomotor Ratings and Specifications

2 1 4 SGMGH Servomotors for 1000 r/min

Servomotor Model SGMGH-	Servomotor			Gear					Load Moment of Inertia J at the Motor Shaft (Servomotor + Gear) kg m^2 (lb-in-s ²)	Gear Moment of Inertia J kg m^2 (lb in s ²)
	Output kW	Rated Speed r/min	Rated Torque N m (lb in)	Gear Ratio	Rated Torque/Efficiency N-m/% (lb in/%)	Instantaneous Peak Torque/Efficiency N m/% (lb in/%)	Rated Speed r/min	Max. Speed r/min		
-12A□BL14	1.2	1000	11.5 (102)	1/5	46/80 (407/80)	112/80 (991/80)	200	400	41.9×10^{-4} (37.1×10^{-3})	10.2×10^{-4} (9.03×10^{-3})
-12A□BL24				1/9	82.8/80 (733/80)	202/80 (1788/80)	111	222	39.5×10^{-4} (35.0×10^{-3})	7.80×10^{-4} (6.90×10^{-3})
-12A□BL54				1/20	184/80 (1629/80)	448/80 (3965/80)	50	100	51.9×10^{-4} (45.9×10^{-3})	20.2×10^{-4} (17.9×10^{-3})
-12A□BL74				1/29	267/80 (2363/80)	650/80 (5753/80)	34	68	45.1×10^{-4} (39.9×10^{-3})	13.4×10^{-4} (11.9×10^{-3})
-12A□BL84				1/45	414/80 (3664/80)	1008/80 (8922/80)	22	44	41.4×10^{-4} (36.6×10^{-3})	9.70×10^{-4} (8.59×10^{-3})
-20A□BL14	2.0		19.1 (169)	1/5	76.4/80 (676/80)	176/80 (1558/80)	200	400	56.2×10^{-4} (49.7×10^{-3})	10.2×10^{-4} (9.03×10^{-3})
-20A□BL24				1/9	138/80 (1221/80)	317/80 (2806/80)	111	222	53.8×10^{-4} (47.6×10^{-3})	7.80×10^{-4} (6.90×10^{-3})
-20A□BL54				1/20	306/80 (2708/80)	704/80 (6231/80)	50	100	66.2×10^{-4} (58.6×10^{-3})	20.2×10^{-4} (17.9×10^{-3})
-30A□BL14	3.0		28.4 (251)	1/5	114/80 (1009/80)	255/80 (2257/80)	200	400	87.9×10^{-4} (77.8×10^{-3})	20.4×10^{-4} (18.1×10^{-3})
-30A□BL24				1/9	204/80 (1806/80)	459/80 (4063/80)	111	222	80.0×10^{-4} (70.8×10^{-3})	12.5×10^{-4} (11.1×10^{-3})

Note Output torque and motor speed produce the following trends in efficiency. Values in the table are at the rated motor speed.

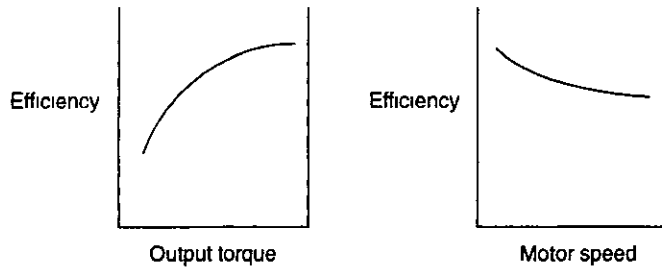

Configuration

This simple planetary gear mechanism is equipped with four planetary gears to which load is evenly distributed via a floating relay ring in each step.

Two gears are used to transmit driving force during forward rotation, and the other two are used to transmit driving force during reverse rotation.

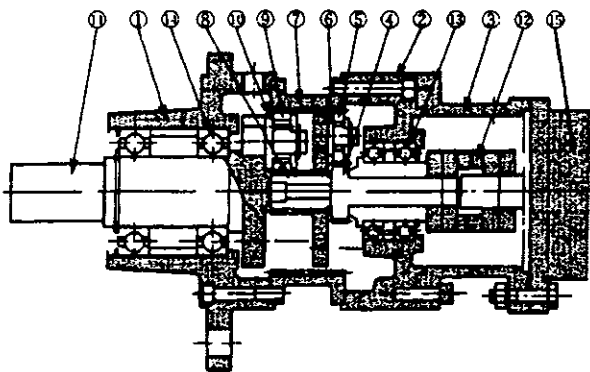

No	Part Name
1	Casing
2	Bracket
3	Motor bracket
4	Primary sun gear
5	Primary planetary gear
6	Primary planetary shaft
7	Internal gear
8	Secondary sun gear
9	Secondary planetary gear
10	Secondary planetary shaft
11	Low-speed shaft
12	Oldham's coupling
13	High-speed shaft bearing
14	Low-speed shaft bearing
15	Motor

Gear Lubrication

The gearbox is filled at the factory

2.1.5 SGMSH Servomotors

■ Rating and Specifications for Standard Servomotors Without Gears

- Time Rating Continuous
- Vibration Class 15 μm or below
- Insulation Resistance 500 VDC, 10 M Ω min
- Ambient Temperature 0 to 40°C
- Excitation Permanent magnet
- Mounting Flange method
- Thermal Class F
- Withstand Voltage 1500 VAC for one minute
- Enclosure Totally enclosed, IP67 self-cooled (except through sections of the shaft)
- Ambient Humidity 20% to 80% (with no condensation)
- Drive Method Direct drive

Table 2.17 SGMSH Standard Servomotor Ratings and Specifications

Servomotor Model SGMSH-		10A□A	15A□A	20A□A	30A□A	40A□A	50A□A
Rated Output *	kW	1.0	1.5	2.0	3.0	4.0	5.0
Rated Torque *	N·m	3.18	4.9	6.36	9.8	12.6	15.8
	lb in	28.1	43.4	56.4	86.8	112	140
Instantaneous Peak Torque *	N·m	9.54	14.7	19.1	29.4	37.8	47.6
	lb in	84.4	130	169	260	336	422
Rated Current *	A (rms)	5.7	9.7	12.7	18.8	25.4	28.6
Instantaneous Max. Current *	A (rms)	17	28	42	56	77	84
Rated Speed *	r/min	3000					
Max. Speed *	r/min	5000					
Torque Constant	N·m/A (rms)	0.636	0.561	0.544	0.573	0.53	0.60
	lb in/A (rms)	5.63	4.97	4.81	5.07	4.69	5.31
Moment of Inertia J	$\times 10^{-4}$ kg·m ²	1.74	2.47	3.19	7.00	9.60	12.3
	$\times 10^{-3}$ lb·in·s ²	1.54	2.19	2.83	6.20	8.50	10.9
Rated Power Rate *	kW/s	57.9	97.2	127	137	166	202
Rated Angular Acceleration *	rad/s ²	18250	19840	19970	14000	13160	12780
Moment of Inertia Time Constant	ms	0.87	0.74	0.62	0.74	0.65	0.59
Inductive Time Constant	ms	7.1	7.7	8.3	13.0	14.1	14.7

* These items and torque-motor speed characteristics quoted in combination with an SGDM Servopack are at an armature winding temperature of 20°C

Note 1. These characteristics are values with the following heat sinks (aluminum plates) attached for cooling
 300 × 300 × 12 (mm) 10A□A to 20A□A Servomotors
 400 × 400 × 20 (mm) 30A□A to 50A□A Servomotors

2 Add the numerical values given below to the moment of inertia in the table for Servomotors fitted with a holding brake
 Other specifications will also change slightly

Servomotor Model SGMSH-		10A□A	15A□A	20A□A	30A□A	40A□A	50A□A
Holding Brake	$\times 10^{-4}$ kg m ²	0.325			2.10		
	$\times 10^{-3}$ lb-in s ²	0.288			1.86		



SGMSH Servomotor Torque-motor Speed Characteristics

The following sections provide the torque-motor speed characteristics of the SGMSH Servomotors

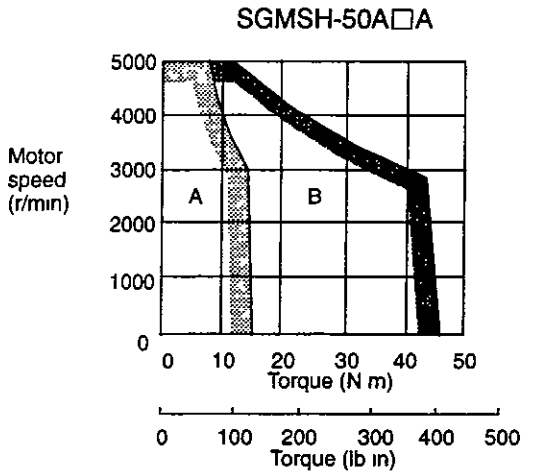
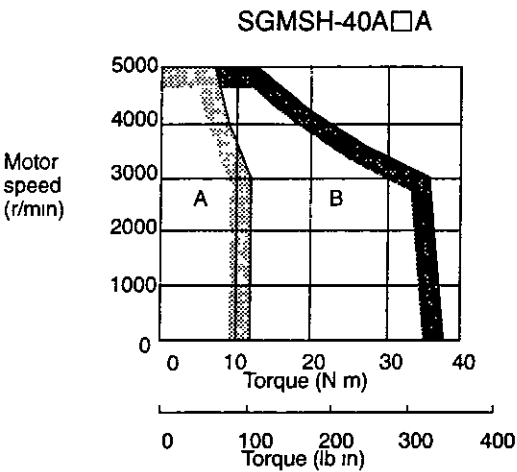
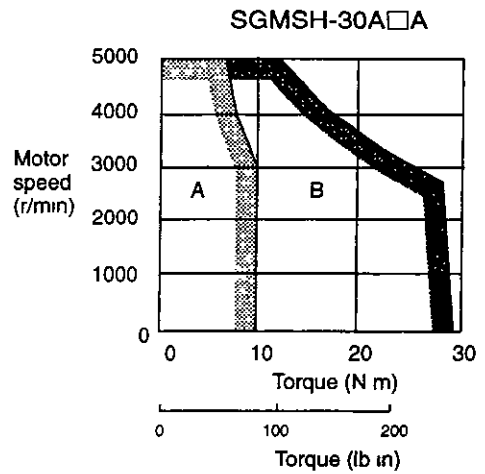
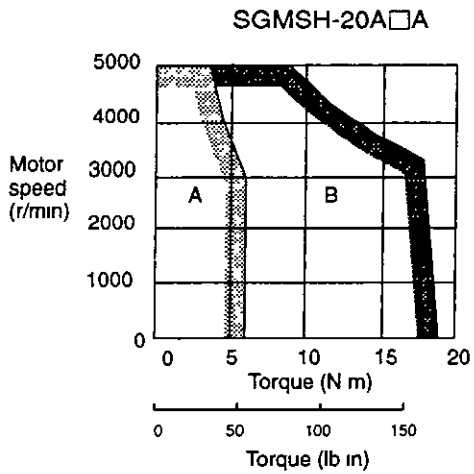
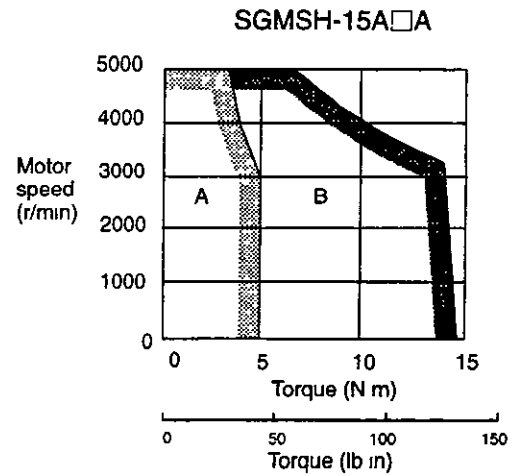
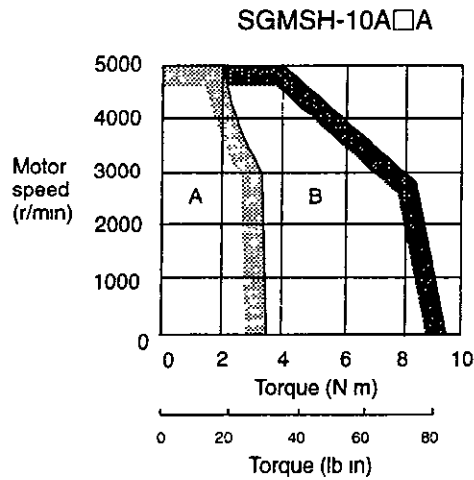

A Continuous Duty Zone
 B Intermittent Duty Zone

■ Ratings and Specifications for SGMSH Servomotors with Low-backlash Gears

- Time Rating Continuous
- Vibration Class 15 μm or below
- Insulation Resistance 500 VDC, 10 M Ω min
- Ambient Temperature 0 to 40°C
- Excitation Permanent magnet
- Mounting Flange method (can be mounted in any direction)
- Rotation Direction Servomotor rotation direction
- Gear Mechanism Planetary gear mechanism
- Thermal Class F
- Withstand Voltage 1500 VAC for one minute
- Enclosure Totally enclosed, IP44 self-cooled (or the equivalent)
- Ambient Humidity 20% to 80% (with no condensation)
- Drive Method Direct drive
- Gear Lubricating Method Grease
- Backlash 0.05° (3 min) at the gear output shaft

Table 2.18 Ratings and Specifications for SGMSH Servomotors with Low-backlash Gears

Servomotor Model SGMSH-	Servomotor			Gear					Load Moment of Inertia J at the Motor Shaft (Servomotor + Gear) kg m ² (lb-in-s ²)	Gear Moment of Inertia J kg-m ² (lb-in-s ²)
	Output kW	Rated Speed r/min	Rated Torque N-m (lb-in)	Gear Ratio	Rated Torque/Efficiency N m/% (lb in/%)	Instantaneous Peak Torque/Efficiency N m/% (lb-in/%)	Rated Speed r/min	Max Speed r/min		
-10A□AL14	1 0	3000	3 18 (28 1)	1/5	12 7/80 (112/80)	38 2/80 (338/80)	600	800	5 18 × 10 ⁻⁴ (4 58 × 10 ⁻³)	3 44 × 10 ⁻⁴ (3 04 × 10 ⁻³)
-10A□AL24				1/9	22 9/80 (203/80)	68 7/80 (608/80)	333	444	4 85 × 10 ⁻⁴ (4 29 × 10 ⁻³)	3 11 × 10 ⁻⁴ (2 75 × 10 ⁻³)
-10A□AL54				1/20	50 9/80 (451/80)	153/80 (1354/80)	150	200	8 53 × 10 ⁻⁴ (7 55 × 10 ⁻³)	6 79 × 10 ⁻⁴ (6 01 × 10 ⁻³)
-10A□AL74				1/29	73 8/80 (653/80)	221/80 (1956/80)	103	138	6 62 × 10 ⁻⁴ (5 86 × 10 ⁻³)	4 88 × 10 ⁻⁴ (4 32 × 10 ⁻³)
-10A□AL84				1/45	115/80 (1018/80)	343/80 (3036/80)	66	89	5 66 × 10 ⁻⁴ (5 01 × 10 ⁻³)	3 92 × 10 ⁻⁴ (3 47 × 10 ⁻³)
-15A□AL14				1 5	3000	4 9 (43 4)	1/5	19 6/80 (173/80)	58 8/80 (520/80)	600
-15A□AL24	1/9	35 3/80 (312/80)	106/80 (938/80)				333	444	7 24 × 10 ⁻⁴ (6 41 × 10 ⁻³)	4 77 × 10 ⁻⁴ (4 22 × 10 ⁻³)
-15A□AL54	1/20	78 4/80 (694/80)	235/80 (2080/80)				150	200	9 26 × 10 ⁻⁴ (8 20 × 10 ⁻³)	6 79 × 10 ⁻⁴ (6 01 × 10 ⁻³)
-15A□AL74	1/29	114/80 (1009/80)	341/80 (3018/80)				103	138	7 35 × 10 ⁻⁴ (6 51 × 10 ⁻³)	4 88 × 10 ⁻⁴ (4 32 × 10 ⁻³)
-15A□AL84	1/45	176/80 (1558/80)	529/80 (4682/80)				66	89	9 05 × 10 ⁻⁴ (8 01 × 10 ⁻³)	6 58 × 10 ⁻⁴ (5 82 × 10 ⁻³)

Servomotor Ratings and Specifications

2 1 5 SGMSH Servomotors

Servomotor Model SGMSH-	Servomotor			Gear					Load Moment of Inertia J at the Motor Shaft (Servomotor + Gear) kg m ² (lb·in·s ²)	Gear Moment of Inertia J kg m ² (lb in s ²)
	Output kW	Rated Speed r/min	Rated Torque N m (lb in)	Gear Ratio	Rated Torque/Efficiency N m/% (lb in/%)	Instantaneous Peak Torque/Efficiency N m/% (lb in/%)	Rated Speed r/min	Max Speed r/min		
-20A□AL14	2 0	3000	6 36 (56 4)	1/5	25 6/80 (227/80)	76 4/80 (676/80)	600	800	6 63 × 10 ⁻⁴ (5 87 × 10 ⁻³)	3 44 × 10 ⁻⁴ (3 04 × 10 ⁻³)
-20A□AL24				1/9	46/80 (407/80)	138/80 (1221/80)	333	444	7 96 × 10 ⁻⁴ (7 05 × 10 ⁻³)	4 77 × 10 ⁻⁴ (4 22 × 10 ⁻³)
-20A□AL54				1/20	102/80 (903/80)	306/80 (2708/80)	150	200	9 98 × 10 ⁻⁴ (8 83 × 10 ⁻³)	6 79 × 10 ⁻⁴ (6 01 × 10 ⁻³)
-20A□AL74				1/29	148/80 (1310/80)	443/80 (3921/80)	103	138	13 5 × 10 ⁻⁴ (11 9 × 10 ⁻³)	10 3 × 10 ⁻⁴ (9 12 × 10 ⁻³)
-20A□AL84				1/45	230/80 (2036/80)	688/80 (6089/80)	66	89	9 77 × 10 ⁻⁴ (8 65 × 10 ⁻³)	6 58 × 10 ⁻⁴ (5 82 × 10 ⁻³)
-30A□AL14	3 0		9 8 (86 8)	1/5	39 2/80 (347/80)	118/80 (1044/80)	600	800	17 2 × 10 ⁻⁴ (15 2 × 10 ⁻³)	10 2 × 10 ⁻⁴ (9 03 × 10 ⁻³)
-30A□AL24				1/9	70 5/80 (624/80)	212/80 (1876/80)	333	444	14 8 × 10 ⁻⁴ (13 1 × 10 ⁻³)	7 80 × 10 ⁻⁴ (6 90 × 10 ⁻³)
-30A□AL54				1/20	157/80 (1390/80)	470/80 (4160/80)	150	200	27 2 × 10 ⁻⁴ (24 1 × 10 ⁻³)	20 2 × 10 ⁻⁴ (17 9 × 10 ⁻³)
-30A□AL74				1/29	227/80 (2009/80)	682/80 (6036/80)	103	138	20 4 × 10 ⁻⁴ (18 1 × 10 ⁻³)	13 4 × 10 ⁻⁴ (11 9 × 10 ⁻³)
-30A□AL84				1/45	353/80 (3124/80)	1058/80 (9364/80)	66	89	16 7 × 10 ⁻⁴ (14 8 × 10 ⁻³)	9 70 × 10 ⁻⁴ (8 59 × 10 ⁻³)
-40A□AL14	4 0		12 6 (112)	1/5	50 4/80 (446/80)	151/80 (1337/80)	600	800	19 8 × 10 ⁻⁴ (17 5 × 10 ⁻³)	10 2 × 10 ⁻⁴ (9 03 × 10 ⁻³)
-40A□AL24				1/9	90 7/80 (803/80)	272/80 (2407/80)	333	444	22 1 × 10 ⁻⁴ (19 6 × 10 ⁻³)	12 5 × 10 ⁻⁴ (11 1 × 10 ⁻³)
-40A□AL54				1/20	202/80 (1788/80)	605/80 (5355/80)	150	200	29 8 × 10 ⁻⁴ (26 4 × 10 ⁻³)	20 2 × 10 ⁻⁴ (17 9 × 10 ⁻³)
-40A□AL74				1/29	292/80 (2584/80)	877/80 (7762/80)	103	138	23 0 × 10 ⁻⁴ (20 4 × 10 ⁻³)	13 4 × 10 ⁻⁴ (11 9 × 10 ⁻³)
-50A□AL14	5 0		15 8 (140)	1/5	63 2/80 (559/80)	190/80 (1682/80)	600	800	32 7 × 10 ⁻⁴ (28 9 × 10 ⁻³)	20 4 × 10 ⁻⁴ (18 1 × 10 ⁻³)
-50A□AL24				1/9	114/80 (1009/80)	343/80 (3036/80)	333	444	24 8 × 10 ⁻⁴ (22 0 × 10 ⁻³)	12 5 × 10 ⁻⁴ (11 1 × 10 ⁻³)
-50A□AL54				1/20	253/80 (2239/80)	762/80 (6744/80)	150	200	32 5 × 10 ⁻⁴ (28 8 × 10 ⁻³)	20 2 × 10 ⁻⁴ (17 9 × 10 ⁻³)

Note 1. The maximum input motor speed for the gear is 4000 r/min

2 Output torque and motor speed produce the following trends in efficiency Values in the table are at the rated motor speed

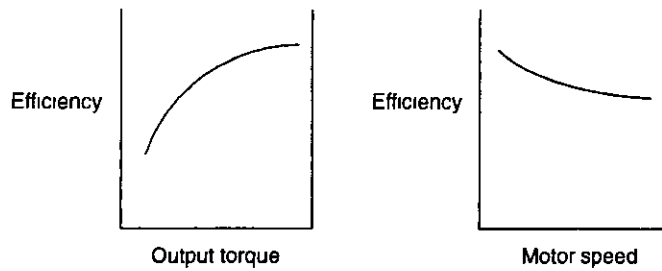

Configuration

This simple planetary gear mechanism is equipped with four planetary gears to which load is evenly distributed via a floating relay ring in each step

Two gears are used to transmit driving force during forward rotation, and the other two are used to transmit driving force during reverse rotation

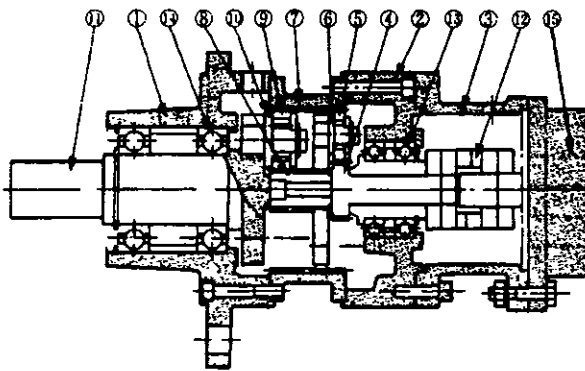

No	Part Name
1	Casing
2	Bracket
3	Motor bracket
4	Primary sun gear
5	Primary planetary gear
6	Primary planetary shaft
7	Internal gear
8	Secondary sun gear
9	Secondary planetary gear
10	Secondary planetary shaft
11	Low-speed shaft
12	Oldham's coupling
13	High-speed shaft bearing
14	Low-speed shaft bearing
15	Motor

Gear Lubrication

The gearbox is filled at the factory

2.1.6 SGMDH Servomotors

■ Ratings and Specifications for Standard Servomotors With Holding Brake

- Time Rating Continuous
- Vibration Class 15 μm or below
- Insulation Resistance 500 VDC, 10 MΩ min
- Ambient Temperature 0 to 40°C
- Excitation Permanent magnet
- Mounting Flange method
- Thermal Class F
- Withstand Voltage 1500 VAC for one minute
- Enclosure Totally enclosed, IP67 self-cooled (except through sections of the shaft)
- Ambient Humidity 20% to 80% (with no condensation)
- Drive Method Direct drive
- Holding Brake 90 VDC, static friction torque 29.4 N m

Servomotor Ratings and Specifications

2.1.6 SGM DH Servomotors

Table 2.19 SGMGH Standard Servomotor Ratings and Specifications

Servomotor Model SGMDH-		22A□A□B	32A□A□B	40A□A□B
Rated Output *	kW	2.2	3.2	4.0
Rated Torque *	N·m	10.5	15.3	19.1
	lb·in	92.9	135	169
Instantaneous Peak Torque *	N·m	36.7	53.5	66.9
	lb·in	325	474	592
Rated Current *	A (rms)	15.7	20.9	23.2
Instantaneous Max. Current *	A (rms)	54	73	77
Rated Speed *	r/min	2000		
Max. Speed *	r/min	3000		
Torque Constant	N·m/A (rms)	0.72	0.78	0.92
	lb·in/A (rms)	6.4	6.9	8.1
Moment of Inertia J	$\times 10^{-4}$ kg·m ²	56.6	74.2	91.8
	$\times 10^{-3}$ lb·in·s ²	50.1	65.7	81.3
Rated Power Rate *	kW/s	19.5	31.5	39.7
Rated Angular Acceleration *	rad/s ²	1850	2060	2080
Moment of Inertia Time Constant	ms	3.7	2.4	2.2
Inductive Time Constant	ms	16.2	18.2	17.8

* These items and torque-motor speed characteristics quoted in combination with an SGDM Servopack are at an armature winding temperature of 20°C

Note These characteristics are values with the following heat sinks (steel plates) attached for cooling
650 × 650 × 35 (mm) 22A□A□B to 40A□A□B Servomotors

SGMDH Servomotor Torque-motor Speed Characteristics

The following sections provide the torque-motor speed characteristics of the SGMDH Servomotors

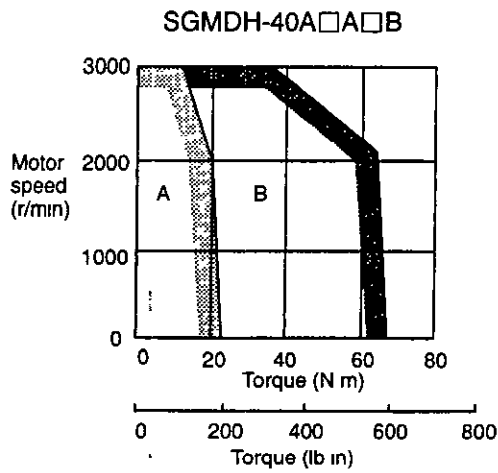
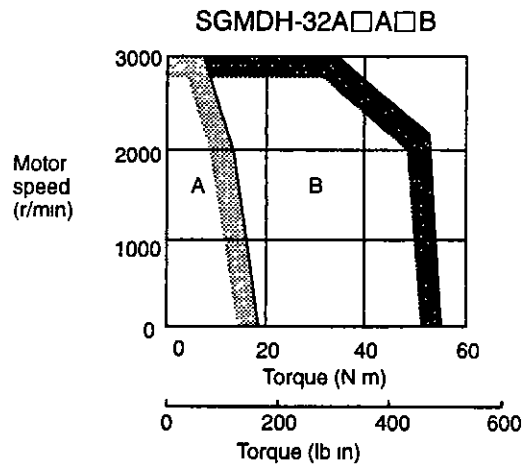
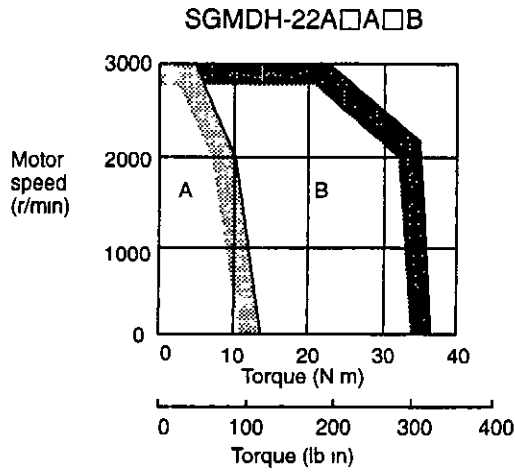

- A Continuous Duty Zone
- B Intermittent Duty Zone



2.2 Mechanical Characteristics

The following sections provide the mechanical characteristics of the SGM□H Servomotors

2.2.1 Allowable Radial and Thrust Loads

The following table shows the allowable loads on the output shafts of the SGM□H Servomotors

Set the thrust and radial loads on the output shaft during Servomotor operation within the range shown in *Table 2 20*

Table 2.20 Allowable Radial and Thrust Loads for the Servomotor

Servomotor Model	Allowable Radial Load * Fr [N (lbf)]	Allowable Thrust Load Fs [N (lbf)]	LR mm (inch)	Reference Diagram
SGMAH-	A3	68 (15)	20 (0 79)	
	A5	68 (15)	20 (0 79)	
	01	78 (18)	54 (12)	
	02	245 (55 1)	74 (17)	
	04	245 (55 1)	74 (17)	
	08	392 (88 1)	147 (33 0)	
SGMPH-	01	78 (18)	20 (0 79)	
	02	245 (55 1)	25 (0 98)	
	04	245 (55 1)	25 (0 98)	
	08	392 (88 1)	35 (1 38)	
	15	490 (110)	35 (1 38)	
SGMGH-	05A□A	490 (110)	58 (2 28)	
	09A□A	490 (110)	58 (2 28)	
	13A□A	686 (154)	79 (3 11)	
	20A□A	1176 (264 3)	79 (3 11)	
	30A□A	1470 (330 4)	113 (4 45)	
	44A□A	1470 (330 4)	113 (4 45)	
	55A□A	1764 (396 4)	116 (4 57)	
	75A□A	1764 (396 4)	116 (4 57)	
	1EA□A	4998 (1124)	2156 (485)	

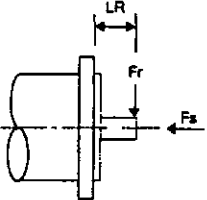
Servomotor Model	Allowable Radial Load * Fr [N (lbf)]	Allowable Thrust Load Fs [N (lbf)]	LR mm (inch)	Reference Diagram
SGMGH- 03A□B	490 (110)	98 (22)	58 (2 28)	
	06A□B	98 (22)		
	09A□B	343 (77 1)	79 (3 11)	
	12A□B	490 (110)		
	20A□B	490 (110)		
	30A□B	490 (110)	113 (4 45)	
	40A□B	588 (132 1)		
	55A□B	588 (132 1)		
SGMSH- 10A	686 (154)	196 (44 1)	45 (1 77)	
	15A	196 (44 1)	63 (2 48)	
	20A	196 (44 1)		
	30A	392 (88 1)		
	40A	392 (88 1)		
	50A	392 (88 1)	55 (2 17)	
SGMDH- 22A	1176 (264 3)	490 (110)		
	32A	490 (110)		
	40A	490 (110)	65 (2 56)	

* The allowable radial load is the maximum load that can be applied up to the end of the output shaft

2.2.2 Mechanical Tolerance

The following table shows tolerances for SGM□H Servomotor output shaft and installation area. See the dimensional drawing of the individual Servomotor for more details on tolerances.

Tolerance T. I. R. (Total Indicator Reading)		Reference Diagram
Perpendicularity between the flange face and output shaft	0.04 (A)	
Mating concentricity of the flange O.D.	0.04 (B)	
Run-out at the end of the shaft	0.02 (C)	

2.2.3 Direction of Servomotor Rotation

Positive rotation of the Servomotor is counterclockwise when viewed from the load.

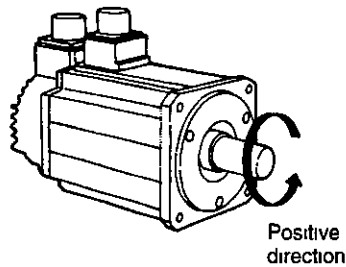

2.2.4 Impact Resistance

Mount the Servomotor with the axis horizontal. The Servomotor will withstand the following vertical impacts:

- **Impact Acceleration: 490 m/s²**
- **Number of Impacts: 2**

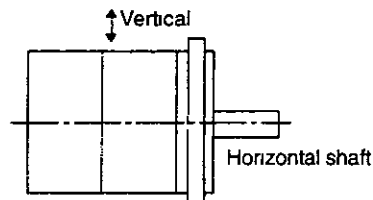

Impact applied to the Servomotor

IMPORTANT

SGM□H Servomotors have a precision detector attached to the end of the shaft opposite the load. Avoid direct impact on the shaft because it may damage the detector.

2.2.5 Vibration Resistance

Mount the Servomotor with the axis horizontal. The Servomotor will withstand the following vibration acceleration in three directions: Vertical, side to side, and front to back.

- **Vibration Acceleration: 49m/s^2 (SGMAH,SGMPH)**
- **Vibration Acceleration: 24.5m/s^2 (SGMSH,SGMGH, SGMDH)**

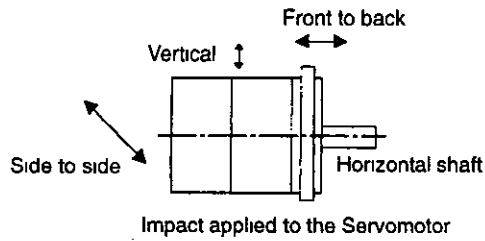

2.2.6 Vibration Class

The vibration class for the SGM□H Servomotors at rated motor speed is as follows:

- **Vibration Class: $15\ \mu\text{m}$ or below**

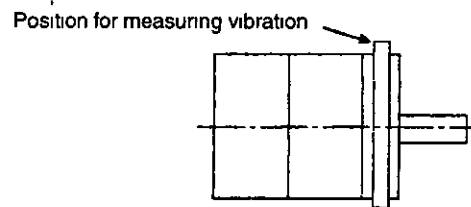

◆ Vibration Class

A vibration class of $15\ \mu\text{m}$ or below indicates a total vibration amplitude of $15\ \mu\text{m}$ maximum on the Servomotor during rated rotation.

3

Servopack Ratings and Characteristics

This chapter provides the ratings, specifications, and mechanical characteristics of the SGDM Servopacks



3.1 Ratings and Specifications	3 -2
3 1 1 Combined Specifications	3 -2
3 1 2 Ratings and Specifications	3 -7
3 2 Characteristics	3 -14
3 2 1 Overload Characteristics	3 -14
3 2 2 Starting and Stopping Time	3 -15
3 2 3 Load Inertia	3 -15
3 2 4 Overhanging Loads	3 -19

3.1 Ratings and Specifications

3.1.1 Combined Specifications

Tables 3 1 and 3 4 provides specifications of the SGDM Servopacks and SGMAH, SGMP, SGMGH, and SGMSH combinations

Table 3 1 Servopack and SGMAH/SGMPH Servomotor Combination Specification at 200 V

Voltage			Single-phase 200 V					Three-phase 200 V					
Servopack Model SGDM-			A3AD	A5AD	01AD	02AD	04AD	05AD	08AD	10AD	15AD	20AD	30AD
			A3ADA	A5ADA	01ADA	02ADA	04ADA	05ADA	08ADA	10ADA	15ADA	20ADA	30ADA
SGMAH Series	Applicable Servomotor	Model SGMAH-	A3A	A5A	01A	02A	04A	-	08A	-	-	-	-
		Capacity (kW)	0.03	0.05	0.1	0.2	0.4	-	0.75	-	-	-	-
		Motor Speed (r/min)	Rated 3000/maximum 5000										
	Applicable Encoder		Standard 13-bit incremental encoder										
	Continuous Output Current A (rms)		0.44	0.64	0.91	2.1	2.8	-	4.4	-	-	-	-
	Max. Output Current A (rms)		1.3	2.0	2.8	6.5	8.5	-	13.4	-	-	-	-
	Allowable Regenerative Energy*1 (Joules)		18.5		37.1			-					
	Allowable Regenerative Frequency*2 (times/min)		-					-	89	-			

Voltage			Single-phase 200 V					Three-phase 200 V					
Servopack Model SGDM-			A3AD	A5AD	01AD	02AD	04AD	05AD	08AD	10AD	15AD	20AD	30AD
			A3ADA	A5ADA	01ADA	02ADA	04ADA	05ADA	08ADA	10ADA	15ADA	20ADA	30ADA
SGMPH Series	Applicable Servo- motor	Model SGMPH-	-	-	01A	02A	04A	-	08A	-	15A	-	-
		Capacity (kW)	-	-	0.1	0.2	0.4	-	0.75	-	1.5	-	-
		Motor Speed (r/min)	Rated 3000/maximum 5000										
	Applicable Encoder		Standard 13-bit incremental encoder										
	Continuous Output Current A (rms)		-	-	0.89	2.0	2.6	-	4.1	-	7.5	-	-
	Max. Output Current A (rms)		-	-	2.8	6.0	8.0	-	13.9	-	23.0	-	-
	Allowable Regenerative Energy* ¹ (Joules)		-	-	37.1			-	-				
	Allowable Regenerative Frequency* ² (times/min)		-	-	-			-	29	-	17	-	

* 1 Allowable regenerative energy is the value with an AC input power supply voltage of 200 Vrms. The allowable regenerative energy may vary with power supply fluctuations.

* 2 Allowable regenerative frequency is applicable to a single Servomotor that repeatedly performs acceleration/ deceleration operations by repeating the motor speed between 0 and the maximum speed (r/min).

Table 3 2 Servopack and SGMGH Servomotor Combination Specifications at 200 V

Voltage			Three-phase 200 V										
Servopack Model SGDM-			05AD	08AD	10AD	15AD	20AD	30AD	-	-	-	-	-
			05AD A	08AD A	10AD A	15AD A	20AD A	30AD A	50AD A	60AD A	75AD A	1AAD A	1EAD A
SGMGH Series	Appli- cable Servo- motor	Model SGMGH-	05A□ A	-	09A□ A	13A□ A	20A□ A	30A□ A	44A□ A	55A□ A	75A□ A	1AA □A	1EA □A
		Capacity (kW)	0.45	-	0.85	1.3	1.8	2.9	4.4	5.5	7.5	11	15
		Motor Speed (r/min)	Rated 1500/maximum 3000										Rated 1500 /maximum 2000
	Applicable Encoder		Standard 17-bit incremental encoder										
	Continuous Output Current A (rms)		3.8	-	7.1	10.7	16.7	23.8	32.8	42.1	54.7	58.6	78.0
	Max. Output Current A (rms)		11	-	17	28	42	56	84	110	130	140	170
	Allowable Regenerative Frequency *1 (times/min)		34	-	13	10	12	8	11	26*2	36*2	36*2	32*2
SGMGH Series	Appli- cable Servo- motor	Model SGMGH-	03A□ B	06A□ B	09A□ B	12A□ B	20A□ B	30A□ B	40A□ B	55A□ B	-	-	-
		Capacity (kW)	0.3	0.6	0.9	1.2	2.0	3.0	4.0	5.5	-	-	-
		Motor Speed (r/min)	Rated 1000/maximum 2000										
	Applicable Encoder		Standard 17-bit incremental encoder										
	Continuous Output Current A (rms)		3.0	5.7	7.6	11.6	18.5	24.8	30	42.2	-	-	-
	Max. Output Current A (rms)		7.3	13.9	16.6	28	42	56	84	110	-	-	-
	Allowable Regenerative Frequency *1 (times/min)		96	39	22	15	20	13	20	44*2	-	-	-

* 1 Allowable regenerative frequency is applicable to a single Servomotor that repeatedly performs acceleration/ deceleration operations by repeating the motor speed between 0 and the maximum speed (r/min)

* 2 The allowable regenerative frequency values (times/min) for the SGDM-60ADA to SGDM-1EADA are applicable when the JUSP-RA04 or JUSP-RA05 Regenerative Resistor Unit is used for each Servopack. See 5 2 5 Regenerative Resistor Unit for details on Regenerative Resistor Units

Table 3.3 Servopack and SGMSH/SGMDH Servomotor Combination Specifications at 200 V

Voltage			Three-phase 200 V								
Servopack Model SGDM-			05AD	08AD	10AD	15AD	20AD	30AD	-		
			05ADA	08ADA	10ADA	15ADA	20ADA	30ADA	50ADA		
SGMSH Series	Appli- cable Servo- motor	Model SGMSH-	-	-	10A	15A	20A	30A	40A	50A	
		Capacity (kW)	-	-	1.0	1.5	2.0	3.0	4.0	5.0	
		Motor Speed (r/min)	Rated 3000/maximum 5000								
	Applicable Encoder		Standard 17-bit incremental encoder								
	Continuous Output Current A (rms)		-	-	5.7	9.7	12.7	18.8	25.4	28.6	
	Max. Output Current A (rms)		-	-	17	28	42	56	77	84	
	Allowable Regenerative Frequency * (times/min)		-	-	39	31	48	20	29	22	
SGMDH Series	Appli- cable Servo- motor	Model SGMDH-	-	-	-	-	-	22A	32A	40A	
		Capacity (kW)	-	-	-	-	-	2.2	3.2	4.0	
		Motor Speed (r/min)	Rated 3000/maximum 5000								
	Applicable Encoder		Standard 17-bit incremental encoder								
	Continuous Output Current A (rms)		-	-	-	-	-	15.7	20.9	23.2	
	Max. Output Current A (rms)		-	-	-	-	-	54	73	77	
	Allowable Regenerative Frequency * (times/min)		-	-	-	-	-	7	11	8	

* Allowable regenerative frequency is applicable to a single Servomotor that repeatedly performs acceleration/ deceleration operations by repeating the motor speed between 0 and the maximum speed (r/min)

Table 3.4 Servopack and SGMAH/SGMPH Servomotor Combination Specification at 100 V

Voltage			Single-phase 100 V			
Servopack Model SGDM-			A3BD	A5BD	01BD	02BD
			A3BDA	A5BDA	01BDA	02BDA
SGMAH Series	Appli- cable Servo- motor	Model SGMAH-	A3B	A5B	01B	02B
		Capacity (kW)	0.03	0.05	0.1	0.2
		Motor Speed (r/min)	Rated 3000/maximum 5000			
	Applicable Encoder		Standard 13-bit incremental encoder			
	Continuous Output Current A (rms)		0.66	0.95	2.4	3.0
	Max. Output Current A (rms)		2.0	2.9	7.2	9.0
	Allowable Regenerative Energy* (Joules)		7.8	15.7		
	SGMPH Series	Appli- cable Servo- motor	Model SGMPH-	-	-	01B
Capacity (kW)			-	-	0.1	0.2
Motor Speed (r/min)			Rated 3000/maximum 5000			
Applicable Encoder		Standard 13-bit incremental encoder				
Continuous Output Current A (rms)		-	-	2.2	2.7	
Max. Output Current A (rms)		-	-	7.1	8.4	
Allowable Regenerative Energy* (Joules)		-		15.7		

* Allowable regenerative energy is the value with an AC input power supply voltage of 100 Vrms. The allowable regenerative energy may vary with power supply fluctuations.



Refer to the Σ -II Series SGM□H/SGDM User's Manual Design and Maintenance (Manual No. SIE-S800-31.2) for more details on allowable regenerative energy and frequency.

3.1.2 Ratings and Specifications

The following table shows ratings and specifications for the SGDM Servopack. Refer to them as required when selecting a Servopack.

Table 3 5 Servopack Ratings and Specifications 1

Servopack Model SGDM-			A3	A5	01	02	04	05	08	10	15	20	
Applicable Servomotor	200V	SGMAH-□A	A3A	A5A	01A	02A	04A	-	08A	-	-	-	
		SGMPH-□A	-	-	01A	02A	04A	-	08A	-	15A	-	
		SGMGH-□A□A (1500r/min)	-	-	-	-	-	05	-	09	13	20	
		SGMGH-□A□B (1000r/min)	-	-	-	-	-	03	06	09	12	20	
		SGMSH-□A	-	-	-	-	-	-	-	10	15	20	
	100V	SGMAH-□B	A3B	A5B	01B	02B	-	-	-	-	-	-	-
		SGMPH-□B	-	-	01B	02B	-	-	-	-	-	-	-
Basic Specifications	Max. Applicable Servomotor Capacity [kW]		0.03	0.05	0.1	0.2	0.4	0.5	0.75	1.0	1.5	2.0	
	200V	Continuous Output Current [A rms]	0.44	0.64	0.91	2.1	2.8	3.8	5.7	7.6	11.6	18.5	
		Max. Output Current [A rms]	1.3	2.0	2.8	6.5	8.5	11.0	13.9	17	28	42	
	100V	Continuous Output Current [A rms]	0.66	0.95	2.4	3.0	-	-	-	-	-	-	
		Max. Output Current [A rms]	2.0	2.9	7.2	9.0	-	-	-	-	-	-	
	Input Power Supply	200/100 V Servopack Capacity Range		For single-phase 200 VAC				For three-phase 200 VAC					
				For single-phase 100 VAC				-					
		Main circuit *1		Three phase (or single-phase) 200 to 230 VAC +10 to -15%, 50/60 Hz, or single phase 100 to 115 VAC +10 to -15%, 50/60 Hz									
	Control Circuit *1		Single-phase 200 to 230 VAC +10 to -15%, 50/60 Hz, or single-phase 100 to 115 VAC +10 to -15%, 50/60 Hz										
	Control Method			Single or three-phase full-wave rectification IGBT-PWM (sine-wave driven)									
Feedback			Serial encoder 13-, 16-, or 17-bit (incremental/absolute value) * The 13 bit encoder is incremental only										
Operating Conditions	Ambient/Storage Temperature *2		0 to +55°C/-20 to +85°C										
	Ambient/Storage Humidity		90% RH or less (with no condensation)										
	Vibration/Shock Resistance		4.9 m/s ² /19.6 m/s ²										
Configuration			Base mounted (Can be rack mounted with optional specifications)										
Approx Mass [kg] (lb)	For 200 V		0.8 (1.764)				1.1 (2.43)	1.7 (3.74)			2.8 (6.17)	3.8 (8.38)	
	For 100 V		0.8 (1.764)				1.1 (2.43)	-					

Servopack Ratings and Characteristics

3 1 2 Ratings and Specifications

Servopack Model SGDM-			A3	A5	01	02	04	05	08	10	15	20	
Speed/ torque Control Modes	Performance	Speed Control Range	1 5000 (The lowest speed of the speed control range is the speed at which the Servomotor will not stop with a rated torque load)										
		Speed Regulation *3	Load Regulation	0 to 100% load 0.01% max (at rated speed)									
			Voltage Regulation	Rated voltage $\pm 10\%$ 0% (at rated speed)									
			Temperature Regulation	$25 \pm 25^\circ\text{C}$ $\pm 0.1\%$ max (at rated speed)									
		Frequency Characteristics	400 Hz (at $J_L = J_M$)										
		Torque Control Tolerance (Repeatability)	$\pm 2\%$										
		Soft Start Time Setting	0 to 10 s (Can be set individually for acceleration and deceleration)										
	Input Signals	Speed Reference Input	Reference Voltage *4	± 6 VDC (Variable setting range ± 2 to ± 10 VDC) at rated torque (forward rotation with positive reference), input voltage ± 12 V (max)									
			Input Impedance	About 14 k Ω									
			Circuit Time Constant	-									
		Torque Reference Input	Reference Voltage *4	± 3 VDC (Variable setting range ± 1 to ± 10 VDC) at rated torque (forward rotation with positive reference), input voltage ± 12 V (max)									
			Input Impedance	About 14 k Ω									
			Circuit Time Constant	About 47 μs									
		Contact Speed Reference	Rotation Direction Selection	With P control signal									
Speed Selection	With forward/reverse current limit signal (speed 1 to 3 selection), Servomotor stops or another control method is used when both are OFF												
Position Control Modes	Performance	Bias Setting	0 to 450 r/min (setting resolution 1 r/min)										
		Feed-forward Compensation	0 to 100% (setting resolution 1%)										
		Position Completed Width Setting	0 to 250 reference units (setting resolution 1 reference unit)										
	Input Signals	Reference Pulse	Type	Sign + pulse train, 90° phase difference 2-phase pulse (A phase + B phase), or CCW + CW pulse train									
			Form	Line driver (+5 V level), open collector (+5 V or +12 V level)									
			Frequency	500/200 kpps max (line driver/open collector)									
	Control Signal	Clear Signal (input pulse form identical to reference pulse)											
	Built-in Open Collector Power Supply *5	+12 V (1 k Ω resistor built-in)											

Servopack Model SGDM-			A3	A5	01	02	04	05	08	10	15	20	
I/O Signals	Position Output	Form	A-, B-, C-phase line driver S-phase line driver (only with an absolute encoder)										
		Frequency Dividing Ratio	Any										
	Sequence Input	Signal allocation can be modified.	Servo ON, P control (or Control Mode switching, forward/reverse motor rotation by internal speed setting, zero clamping, reference pulse prohibited), forward run prohibited (P-OT), reverse run prohibited (N-OT), alarm reset, forward current limit and reverse current limit (or internal speed selection)										
	Sequence Output	Fixed Output	Servo alarm, 3-bit alarm codes										
Signal allocation can be modified.		Select any three of the following signals: positioning completion (speed coincidence), Servomotor rotation, servo ready, current limit, speed limit, brake release, warning, and NEAR signals											
Built-in Functions	Dynamic Brake (DB)		Operated at main power OFF, servo alarm, servo OFF or overtravel										
	Regenerative Processing		Externally mounted regenerative resistor	Built-in									
	Overtravel Prevention (OT)		Dynamic brake stop at P-OT or N-OT, deceleration to a stop, or free run to a stop										
	Electronic Gear		$0.01 \leq B/A \leq 100$										
	Protection		Overcurrent, overvoltage, low voltage, overload, regeneration error, main circuit voltage error, heat sink overheat, power open phase, overflow, overspeed, encoder error, overrun, CPU error, parameter error, etc										
	LED Display		CHARGE, POWER, five 7-segment LEDs (built-in Digital Operator functions)										
	Analog Monitor (5CN)		Analog monitor connector built in for monitoring speed, torque and other reference signals Speed 1 V/1000 r/min Torque 1 V/rated torque Pulses remaining 0.05 V/reference unit or 0.05 V/100 reference units										
	Communications	Interface		Digital Operator (hand type), RS-422A port such as for a personal computer (RS-232C ports under certain conditions)									
		1·N Communications		Up to N = 14 for RS-422A port									
		Axis Address Setting		Set with user constants									
Functions		Status display, user constant setting, monitor display, alarm traceback display, JOG and auto-tuning operations, speed/torque reference signal and other drawing functions											
Others		Reverse rotation connection, home position search, automatic Servomotor ID, DC reactor connection terminal for high power supply frequency control											



* 1 Power voltage must not exceed 230 V +10% (253 V) or 115 V + 10% (127 V) A step-down transformer is required if the voltage exceeds these values

* 2 Use the Servopack within the ambient temperature range. When installed in a box, the temperature must not exceed the ambient temperature range

Servopack Ratings and Characteristics

3 1 2 Ratings and Specifications

* 3 Speed regulation is defined as follows

$$\text{Speed regulation} = \frac{\text{No-load motor speed} - \text{Total load motor speed}}{\text{Rated motor speed}} \times 100\%$$

The motor speed may change due to voltage variations or amplifier drift and changes in processing resistance due to temperature variation. The ratio of speed changes to the rated speed represent speed regulation due to voltage and temperature variations.

* 4 Forward is clockwise viewed from the non-load side of the Servomotor (Counterclockwise viewed from the load and shaft end)

* 5 The built-in open collector power supply is not electrically insulated from the control circuit in the Servopack

Table 3.6 Servopack Ratings and Specifications 2

Servopack Model SGDM-			30	50	60	75	1A	1E	
Applicable Servomotor	200V	SGMGH-□A□A (1500r/min)	30	44	55	75	1A	1E	
		SGMGH-□A□B (1000r/min)	30	40	55	-	-	-	
		SGMSH-□A	30	40	50	-	-	-	
		SGMDH-□A	22	32	40	-	-	-	
Basic Specifications	Max. Applicable Servomotor Capacity [kW]		3.0	5.0	6.0	7.5	11	15	
	200V	Continuous Output Current [A rms]	24.8	32.9	46.9	54.7	58.6	78.0	
		Max Output Current [A rms]	56	84	110	130	140	170	
	Input Power Supply	Main circuit *1	Three phase 200 to 230 VAC +10 to -15%, 50/60 Hz						
		Control Circuit *1	Single phase 200 to 230 VAC +10 to -15%, 50/60 Hz						
	Control Method		Three-phase full-wave rectification IGBT-PWM (sine-wave driven)						
	Feedback		Serial encoder 17-bit (incremental/absolute value)						
	Operating Conditions	Ambient/Storage Temperature *2		0 to +55°C/-20 to +85°C					
		Ambient/Storage Humidity		90% RH or less (with no condensation)					
		Vibration/Shock Resistance		4.9 m/s ² /19.6 m/s ²					
Configuration			Base mounted (Can be rack mounted with optional specifications)			Base mounted (Can be duct-ventilated with optional specifications)			
Approx Mass [kg] (lb)			3.8 (8.36)	5.5 (12.1)	15 (33.0)	25 (55.1)	26 (57.3)		

Servopack Model SGDM-		30	50	60	75	1A	1E
Speed/torque Control Modes	Perform- ance	Speed Control Range		1 5000 (The lowest speed of the speed control range is the speed at which the Servomotor will not stop with a rated torque load)			
		Speed Regulation *3	Load Regulation	0 to 100% load 0.01% max (at rated speed)			
			Voltage Regulation	Rated voltage $\pm 10\%$ 0% (at rated speed)			
			Temperature Regulation	25 ± 25 °C $\pm 0.1\%$ max (at rated speed)			
		Frequency Characteristics		400 Hz (at $J_L = J_M$)			
		Torque Control Tolerance (Repeatability)		$\pm 2\%$			
		Soft Start Time Setting		0 to 10 s (Can be set individually for acceleration and deceleration)			
	Input Signals	Speed Reference Input	Reference Voltage *4	± 6 VDC (Variable setting range ± 2 to ± 10 VDC) at rated torque (forward rotation with positive reference), input voltage ± 12 V (max)			
			Input Impedance	About 14 k Ω			
			Circuit Time Constant	—			
		Torque Reference Input	Reference Voltage *4	± 3 VDC (Variable setting range ± 1 to ± 10 VDC) at rated torque (forward rotation with positive reference), input voltage ± 12 V (max)			
			Input Impedance	About 14 k Ω			
			Circuit Time Constant	About 47 μ s			
		Contact Speed Reference	Rotation Direction Selection	With P control signal			
			Speed Selection	With forward/reverse current limit signal (speed 1 to 3 selection), Servomotor stops or another control method is used when both are OFF			



Servopack Ratings and Characteristics

3 1 2 Ratings and Specifications

Servopack Model SGDM-			30	50	60	75	1A	1E	
Position Control Modes	Performance	Bias Setting	0 to 450 r/min (setting resolution 1 r/min)						
		Feed-forward Compensation	0 to 100% (setting resolution 1%)						
		Position Completed Width Setting	0 to 250 reference units (setting resolution 1 reference unit)						
	Input Signals	Reference Pulse	Type	Sign + pulse train, 90° phase difference 2-phase pulse (A phase + B phase), or CCW + CW pulse train					
			Form	Line driver (+5 V level), open collector (+5 V or +12 V level)					
			Frequency	500/200 kpps max (line driver/open collector)					
	Control Signal		Clear Signal (input pulse form identical to reference pulse)						
Built-in Open Collector Power Supply *5		+12 V (1 kΩ resistor built-in)							
I/O Signals	Position Output	Form	A-, B-, C-phase line driver S-phase line driver (only with an absolute encoder)						
		Frequency Dividing Ratio	Any						
	Sequence Input	Signal allocation can be modified.	Servo ON, P control (or Control Mode switching, forward/reverse motor rotation by internal speed setting, zero clamping, reference pulse prohibited), forward run prohibited (P-OT), reverse run prohibited (N-OT), alarm reset, forward current limit and reverse current limit (or internal speed selection)						
	Sequence Output	Fixed Output	Servo alarm, 3-bit alarm codes						
		Signal allocation can be modified	Selecting three of positioning complete (speed coincidence), during Servomotor rotation, servo ready, during current limit, speed limit, brake release, warning, and NEAR signals						

Servopack Model SGDM-		30	50	60	75	1A	1E
Built-in Functions	Dynamic Brake (DB)		Operated at main power OFF, servo alarm, servo OFF or overtravel				
	Regenerative Processing		Built-in		Externally mounted regenerative resistor		
	Overtravel Prevention (OT)		Dynamic brake stop at P-OT or N-OT, deceleration to a stop, or free run to a stop				
	Electronic Gear		$0.01 \leq B/A \leq 100$				
	Protection		Overcurrent, overvoltage, low voltage, overload, regeneration error, main circuit voltage error, heat sink overheat, power open phase, overflow, over-speed, encoder error, overrun, CPU error, parameter error, etc				
	LED Display		CHARGE, POWER, five 7-segment LEDs (built-in Digital Operator functions)				
	Analog Monitor (5CN)		Analog monitor connector built in for monitoring speed, torque and other reference signals Speed 1 V/1000 r/min Torque 1 V/rated torque Pulses remaining 0.05 V/reference unit or 0.05 V/100 reference units				
	Communica- tions	Interface	Digital Operator (hand type), RS-422A port such as for a personal computer (RS-232C ports under certain conditions)				
		1:N Commu- nications	Up to N = 14 for RS-422A port				
		Axis Address Setting	Set with user constants				
Functions		Status display, user constant setting, monitor display, alarm traceback display, JOG and auto-tuning operations, speed/torque reference signal and other drawing functions					
Others		Reverse rotation connection, home position search, automatic Servomotor ID, DC reactor connection terminal for power supplies designed for minimum harmonics*6					

* 1 Power voltage must not exceed 230 V +10% (253 V) A step-down transformer is required if the voltage exceeds these values

* 2 Use the Servopack within the ambient temperature range When installed in a box, the temperature must not exceed the ambient temperature range

* 3 Speed regulation is defined as follows

$$\text{Speed regulation} = \frac{\text{No-load motor speed} - \text{Total load motor speed}}{\text{Rated motor speed}} \times 100\%$$

The motor speed may change due to voltage variations or amplifier drift and changes in processing resistance due to temperature variation The ratio of speed changes to the rated speed represent speed regulation due to voltage and temperature variations

* 4 Forward is clockwise viewed from the non-load side of the Servomotor (Counterclockwise viewed from the load and shaft end)

* 5 The built-in open collector power supply is not electrically insulated from the control circuit in the Servopack

* 6 DC reactor connection terminal for power supplies designed for minimum harmonics is not included in Servopacks with a capacity of 6 kW or higher

3.2 Characteristics

3.2.1 Overload Characteristics

Servopacks have a built-in overload protective function that protects the Servopacks and Servomotors from overload. Allowable power for the Servopacks is limited by the overload protection function as shown in the figure below.

The overload detection level is set under hot start conditions at a Servomotor ambient temperature of 40°C.

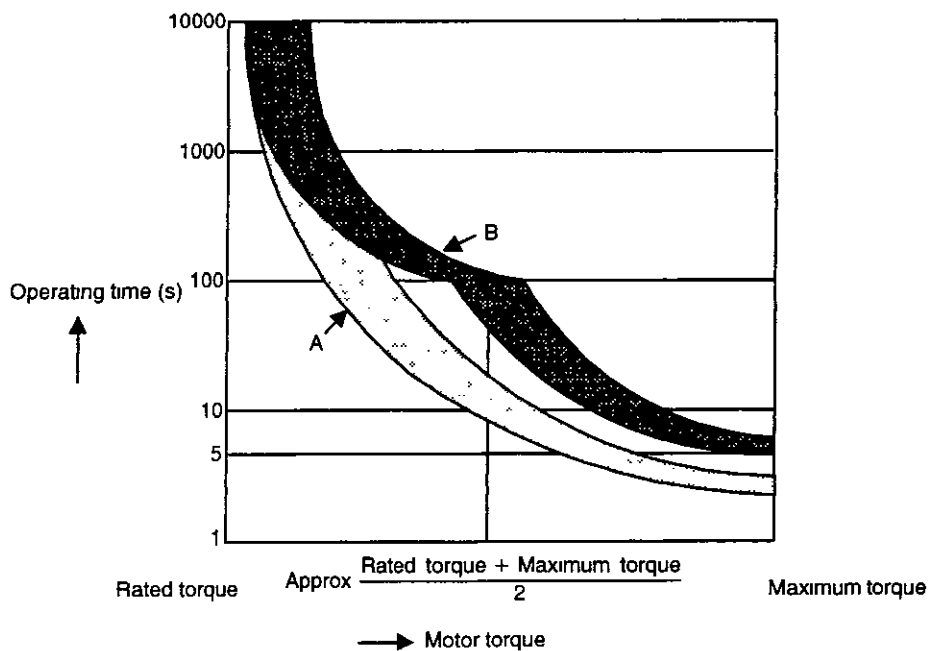

Note The overload protection characteristics of A and B in the figure are applicable when the Servopack is combined with one of the following Servomotors:
 A SGMAH or SGMPH Servomotor with a capacity of 400 W max
 B Others like the SGMAH, SGMPH, SGMGH, SGMSH and SGMDH Servomotors

Figure 3.1 Overload Characteristics



◆ Hot Start

A hot start indicates that both the Servopack and the Servomotor have run long enough at the rated load to be thermally saturated.

3.2.2 Starting and Stopping Time

The motor starting time (t_r) and stopping time (t_f) under a constant load are calculated using the following formulas. Motor viscous torque and friction torque are ignored.

$$\text{Starting time } t_r = \frac{2\pi N_M(J_M + J_L)}{60 (T_{PM} - T_L)} [\text{s}]$$

$$\text{Stopping time } t_f = \frac{2\pi N_M(J_M + J_L)}{60 (T_{PM} + T_L)} [\text{s}]$$

N_M Rated motor speed (r/min)

J_M Motor moment of inertia (kg m^2) ($GD_M^2/4$)

J_L Load converted to shaft moment of inertia (kg m^2) ($GD_L^2/4$)

T_{PM} Instantaneous peak motor torque when combined with a Servopack (N m)

T_L Load torque (N m)

Calculate the torque from the motor current using Servomotor torque constant \times motor current (effective value)

Figure 3 2 shows the motor torque and motor speed timing chart

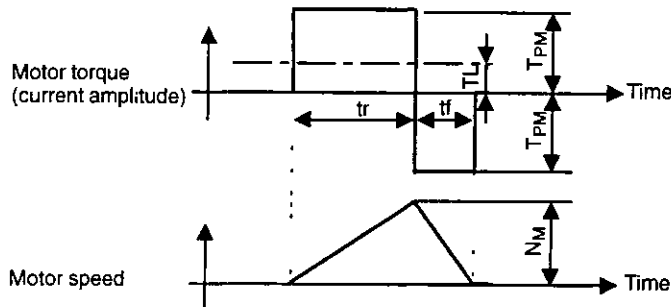

Figure 3 2 Motor Torque (Current Amplitude) and Motor Speed Timing Chart

3.2.3 Load Moment of Inertia

The larger the load moment of inertia, the worse the movement response of the load. The size of the load moment of inertia (J_L) allowable when using a Servomotor depends on motor capacity and is limited to within 5 to 30 times the moment of inertia of each Servomotor (J_M). This value is provided strictly as a guideline and results may vary depending on Servomotor drive conditions.

An overvoltage alarm is likely to occur during deceleration if the load moment of inertia exceeds the allowable load moment of inertia. Servopacks with a built-in regenerative resistor may generate a regeneration overload alarm. Take one of the steps below if this occurs:

- Reduce the torque limit
- Reduce the deceleration rate

- Reduce the maximum motor speed
- Install an externally mounted regenerative resistor if the alarm cannot be cleared. Consult your Yaskawa representative

Regenerative resistors are not built into 30- to 400-W, 200-V Servopacks or 30- to 200-W, 100-V Servopacks. Figure 3 3 and Figure 3 4 show the relationship between the load moment of inertia and motor speed using an example with a load moment of inertia 10 to 30 times the load moment of inertia at the motor shaft.

An externally mounted regenerative resistor is required when this condition is exceeded or if the allowable loss capacity (W) of the built-in regenerative resistor is exceeded due to regenerative drive conditions when a regenerative resistor is already built in.

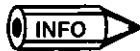

Refer to the Σ -II Series SGM□H/SGDM User's Manual Design and Maintenance (Manual No. SIE-S800-31 2) for more details on the relationship of regenerative energy or frequency to load moment of inertia and motor speed.

■ Allowable Load Moment of Inertia

The following table shows allowable load moment of inertia at the motor shaft.

Servomotor		Allowable Load Moment of Inertia (Moment of Inertia Factor) (See Note)
Series	Capacity Range	
SGMAH (200 V)	30 W to 200 W	× 30
	400 W, 750 W	× 20
SGMPH (200 V)	100 W	× 25
	200 W	× 15
	400 W	× 7
	750 W, 1500 W	× 5
SGMGH	—	× 5
SGMSH	—	× 5
SGMDH	—	× 5

Note The moment of inertia factor is the value for a standard Servomotor without a brake.

■ SGMAH 200-V Servomotors

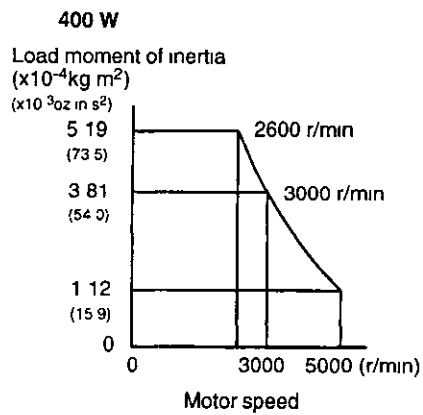
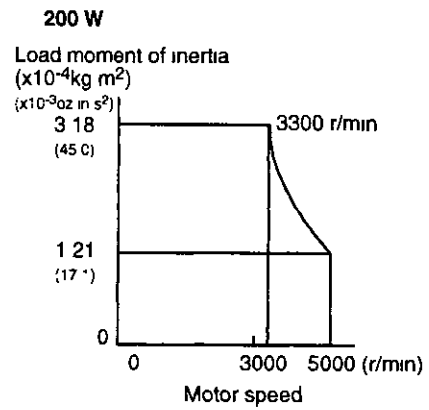
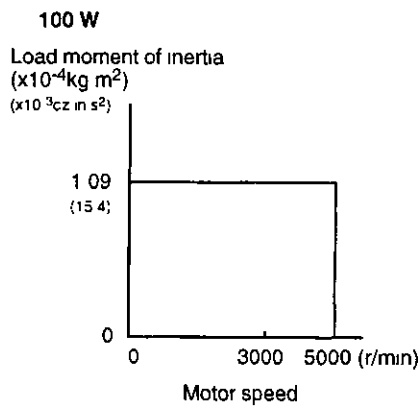
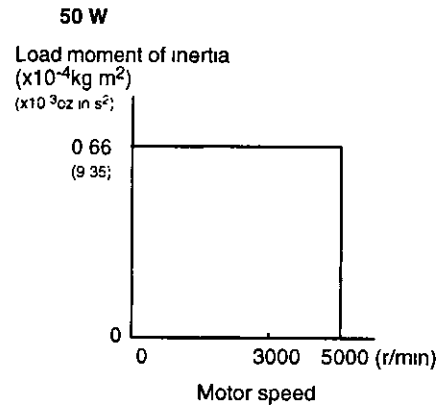
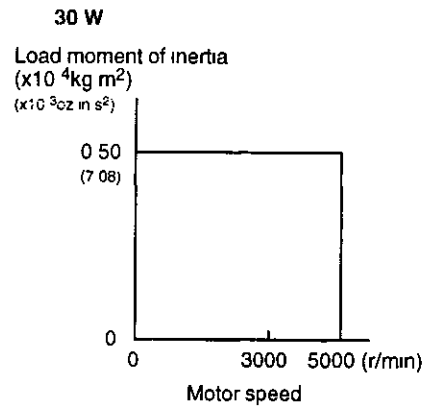

Note The above relationships between the motor speed and load moment of inertia are for an AC input power voltage of 200 Vrms. The relationship will change according to changes in power voltage.

Figure 3.3 Load Moment of Inertia and Motor Speed for SGMAH Servomotors

■ **SGMPH 200-V Servomotors**

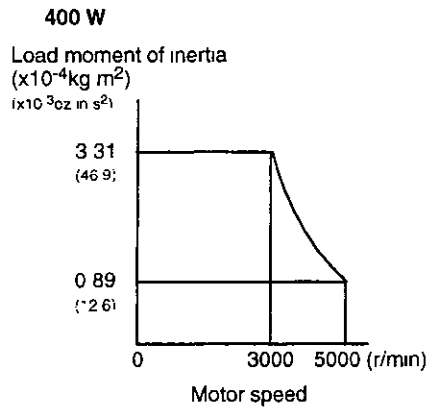
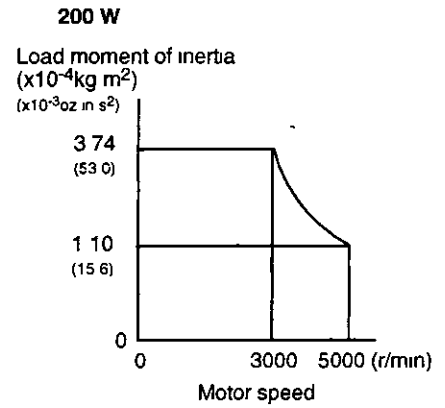
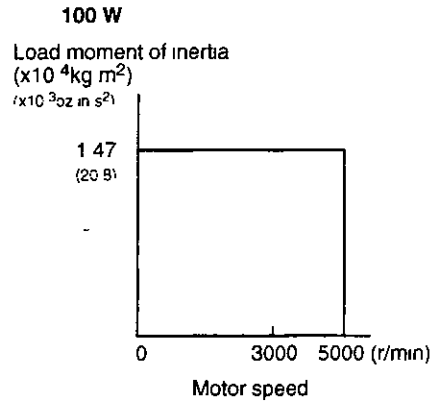

Note The above relationships between the motor speed and load moment of inertia are for an AC input power voltage of 200 Vrms. The relationship will change according to changes in power voltage.

Figure 3.4 Load Moment of Inertia and Motor Speed for SGMPH Servomotors

3.2.4 Overhanging Loads

A Servomotor may not be operated with an overhanging load, i.e., a load which tends to continuously rotate the motor. Figure 3.5 shows a typical example of such a load.

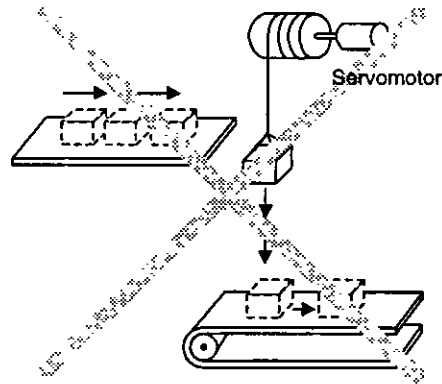

- Vertical Axis Motor Drive without Counterweight

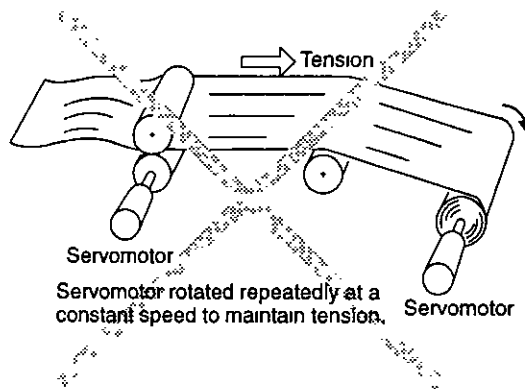

- Feeding Motor Drive

Figure 3.5 Examples of Overhanging Loads

IMPORTANT

- Never operate Servomotors with an overhanging load. Doing so will cause the Servopacks' regenerative brake to be applied continuously and the regenerative energy of the load may exceed the allowable range causing damage to the Servopack.
- The regenerative brake capacity of the SGDM Servopacks is rated for short-term operation approximately equivalent to the time it takes to decelerate to a stop.

3.2.4 Overhanging Loads

A Servomotor may not be operated with an overhanging load, i.e., a load which tends to continuously rotate the motor. Figure 3.5 shows a typical example of such a load.

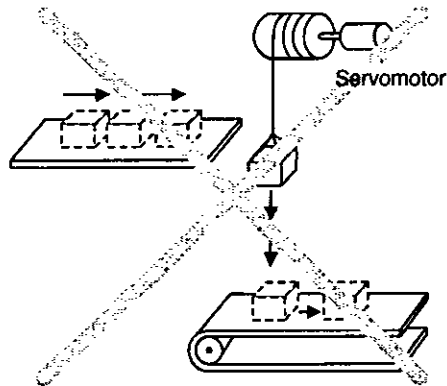

- **Vertical Axis Motor Drive without Counterweight**

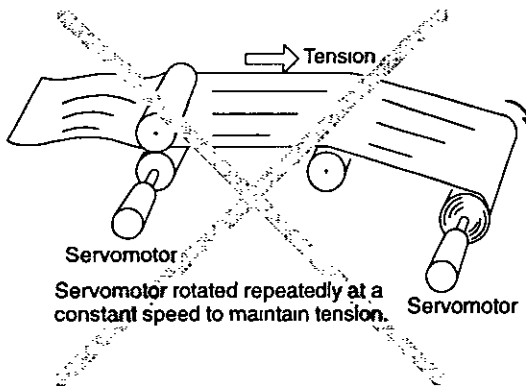

- **Feeding Motor Drive**

Figure 3.5 Examples of Overhanging Loads

IMPORTANT

- Never operate Servomotors with an overhanging load. Doing so will cause the Servopacks' regenerative brake to be applied continuously and the regenerative energy of the load may exceed the allowable range causing damage to the Servopack.
- The regenerative brake capacity of the SGDM Servopacks is rated for short-term operation approximately equivalent to the time it takes to decelerate to a stop.

4

Servodrive Dimensional Drawings

This chapter provides dimensional drawings for the Σ -II Series Servomotors and Servopacks

4.1 Servomotor Dimensional Drawings	4 -2
4 1 1 SGMAH Servomotors	4 -3
4 1 2 SGMPH Servomotors	4 -25
4 1 3 SGMGH Servomotors (1500 r/min)	4 -42
4 1 4 SGMGH Servomotors (1000 r/min)	4 -62
4 1 5 SGMSH Servomotors	4 -82
4 1 6 SGMDH Servomotors	4 -91
4.2 Servopack Dimensional Drawings	4 -97
4 2 1 Base-mounted Servopacks	4 -98
4 2 2 Rack-mounted Servopacks	4 -106
4 2 3 Duct-ventilated Servopacks	4 -112



4.1 Servomotor Dimensional Drawings

The following sections provide dimensional drawings for the Σ -II Series Servomotors

Dimensional drawings for the SGM□H Servomotors are broadly grouped using the following categories: With or without gears or brakes, type of detector, rated motor speed, and Servomotor capacity

Series	Groups of Servomotor Dimensional Drawings	
SGMAH	Standard Servomotors without gears	Without brakes
		With brakes
	Servomotors without brakes and with gears	With low-backlash gears
		With standard backlash gears
	Servomotors with brakes and gears	With low-backlash gears
		With standard backlash gears
SGMPH	Standard Servomotors without gears	Without brakes
		With brakes
	Servomotors without brakes and with gears	With low-backlash gears
		With standard backlash gears
	Servomotors with brakes and gears	With low-backlash gears
		With standard backlash gears
SGMGH (1500 r/min)	Servomotors with 17-bit encoder (absolute/incremental)	
	Servomotors with 17-bit encoder and brakes	
	Servomotors without brakes and with gears	
SGMGH (1000 r/min)	Servomotors with 17-bit encoder (absolute/incremental)	
	Servomotors with 17-bit encoder and brakes	
	Servomotors without brakes and with gears	
SGMSH	Servomotors with 17-bit encoder (absolute/incremental)	
	Servomotors with 17-bit encoder and brakes	
	Servomotors without brakes and with gears	
SGMDH	Servomotors with 17-bit encoder (absolute/incremental)	
	Servomotors with 17-bit encoder and brakes	

4.1.1 SGMAH Servomotors

■ Standard Servomotors Without Gears

SGMAH: 30 W, 50 W, 100 W Without Brakes

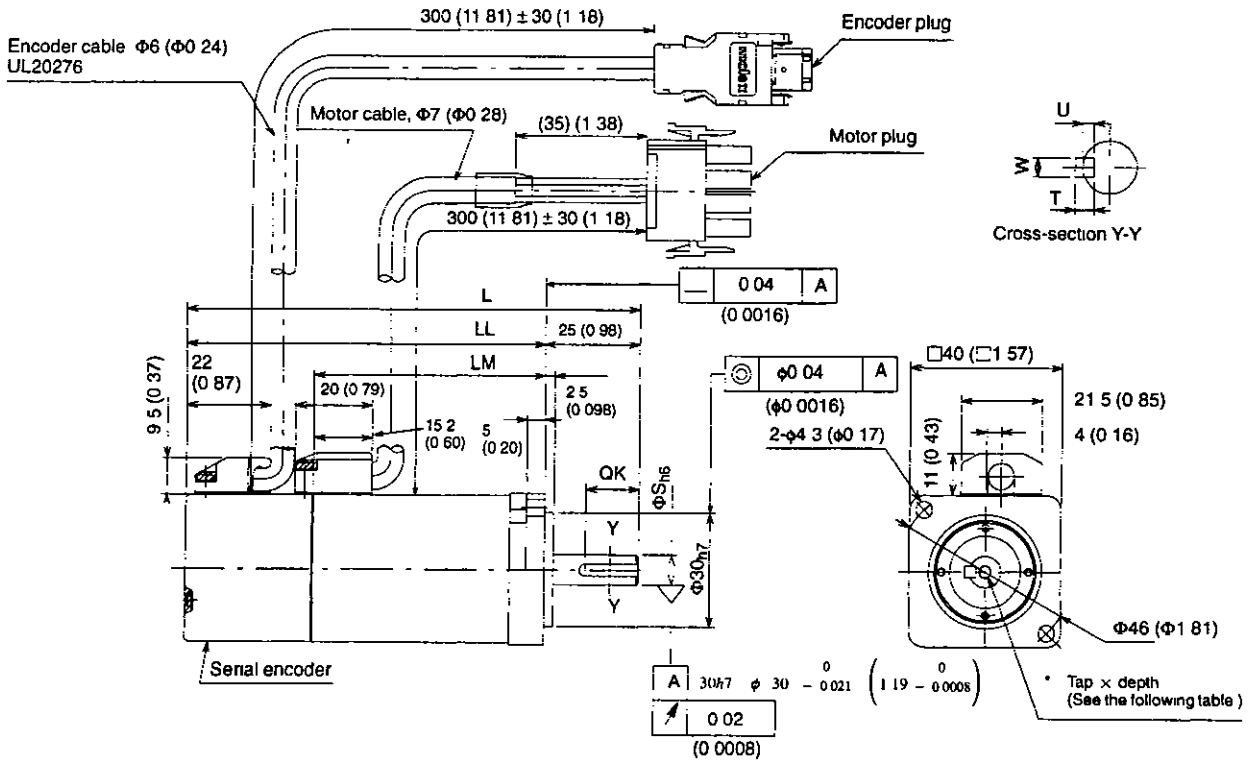

Units mm (in)

Model SGMAH-	L	LL	LM	S	* Tap \times Depth	QK	U	W	T	Approx. Mass kg (lb)
A3□□A21	94.5	69.5	36.5	6	No tap	No key				0.3 (0.661)
A3□□A41	(3.72)	(2.74)	(1.44)	(0.24)	M2.5 \times 5L	14	1.2	2	2	
A3□□A61						(0.55)	(0.047)	(0.079)	(0.079)	
A5□□A21	102.0	77.0	44.0	6	No tap	No key				0.4 (0.882)
A5□□A41	(4.02)	(3.03)	(1.73)	(0.24)	M2.5 \times 5L	14	1.2	2	2	
A5□□A61						(0.55)	(0.047)	(0.079)	(0.079)	
01□□A21	119.5	94.5	61.5	8	No tap	No key				0.5 (1.102)
01□□A41	(4.70)	(3.72)	(2.42)	(0.31)	M3 \times 6L	14	1.8	3	3	
01□□A61						(0.55)	(0.071)	(0.12)	(0.12)	

● Dimensional Tolerances

Model SGMAH-	Shaft-end Dimensions mm (in)
	S
A3□□A21	$6 - 0.008$ ($0.24 - 0.0003$)
A3□□A41	
A3□□A61	

Model SGMAH-	Shaft-end Dimensions mm (in)	
	S	
A5□□A21	$6 - \begin{smallmatrix} 0 \\ -0.008 \end{smallmatrix} \left(0.24 - \begin{smallmatrix} 0 \\ -0.0003 \end{smallmatrix} \right)$	
A5□□A41		
A5□□A61		
01□□A21	$8 - \begin{smallmatrix} 0 \\ -0.009 \end{smallmatrix} \left(0.32 - \begin{smallmatrix} 0 \\ -0.0004 \end{smallmatrix} \right)$	
01□□A41		
01□□A61		

SGMAH: 200 W, 400 W, 750 W Without Brakes

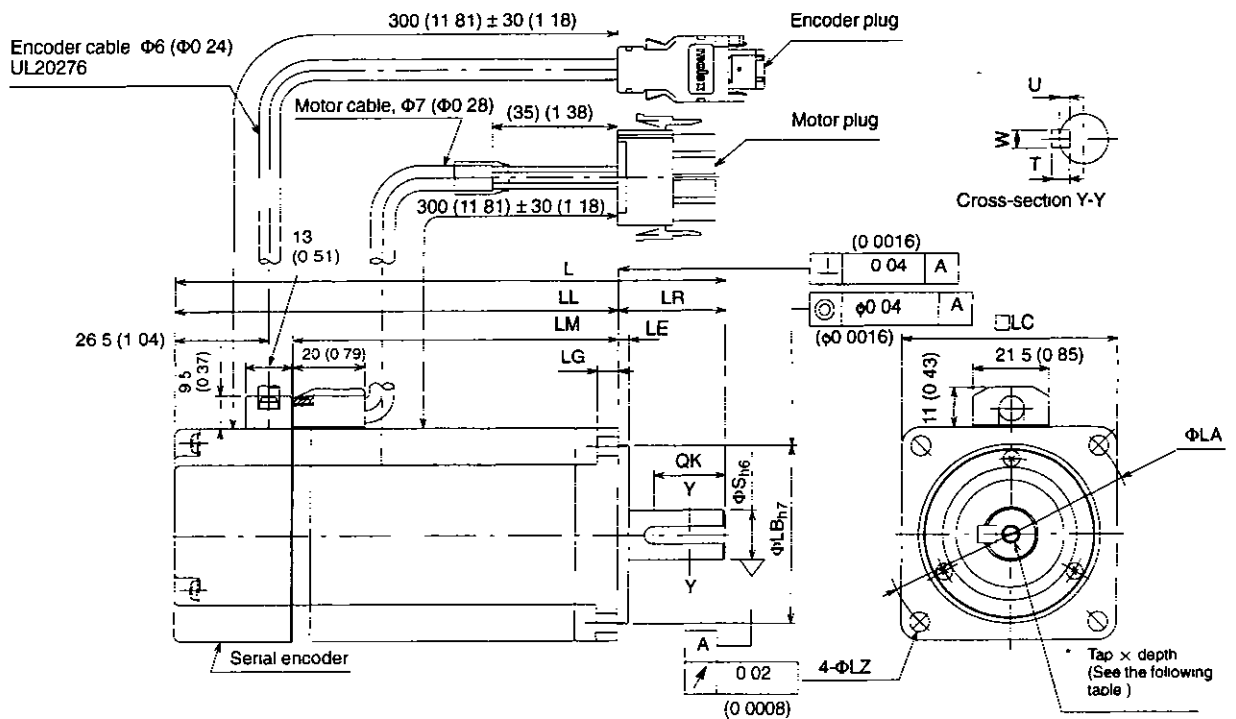

Units mm (in)

Model SGMAH-	L	LL	LM	LR	LE	LG	LC	LA	LZ	S	LB	* Tap \times Depth	QK	U	W	T	Approx. Mass kg (lb)
02□□A21	126.5	96.5	62.5	30	3	6	60	70	5.5	14	50	No tap	No key				1.1 (2.43)
02□□A41	(4.98)	(3.80)	(2.46)	(1.18)	(0.12)	(0.24)	(2.36)	(2.76)	(0.22)	(0.55)	(1.97)	M5 \times 8L	20	3	5	5	
02□□A61													(0.79)	(0.12)	(0.20)	(0.20)	
04A□A21	154.5	124.5	90.5	30	3	6	60	70	5.5	14	50	No tap	No key				1.7 (3.75)
04A□A41	(6.08)	(4.90)	(3.56)	(1.18)	(0.12)	(0.24)	(2.36)	(2.76)	(0.22)	(0.55)	(1.97)	M5 \times 8L	20	3	5	5	
04A□A61													(0.79)	(0.12)	(0.20)	(0.20)	
08A□A21	185	145	111	40	3	8	80	90	7	16	70	No tap	No key				3.4 (7.50)
08A□A41	(7.28)	(5.71)	(4.37)	(1.57)	(0.12)	(0.31)	(3.15)	(3.54)	(0.28)	(0.63)	(2.76)	M5 \times 8L	30	3	5	5	
08A□A61													(1.18)	(0.12)	(0.20)	(0.20)	

• Dimensional Tolerances

Model SGMAH-	Shaft-end Dimensions mm (in)	Flange Face Dimensions mm (in)
	S	LB
02□□A21	14 - ⁰ / _{0.011} (0.56 - ⁰ / _{0.0004})	50 - ⁰ / _{0.025} (1.98 - ⁰ / _{0.0010})
02□□A41		
02□□A61		
04A□A21	14 - ⁰ / _{0.011} (0.56 - ⁰ / _{0.0004})	50 - ⁰ / _{0.025} (1.98 - ⁰ / _{0.0010})
04A□A41		
04A□A61		
08A□A21	16 - ⁰ / _{0.011} (0.64 - ⁰ / _{0.0004})	70 - ⁰ / _{0.030} (2.78 - ⁰ / _{0.0012})
08A□A41		
08A□A61		

SGMAH: 30 W, 50 W, 100 W With Brakes

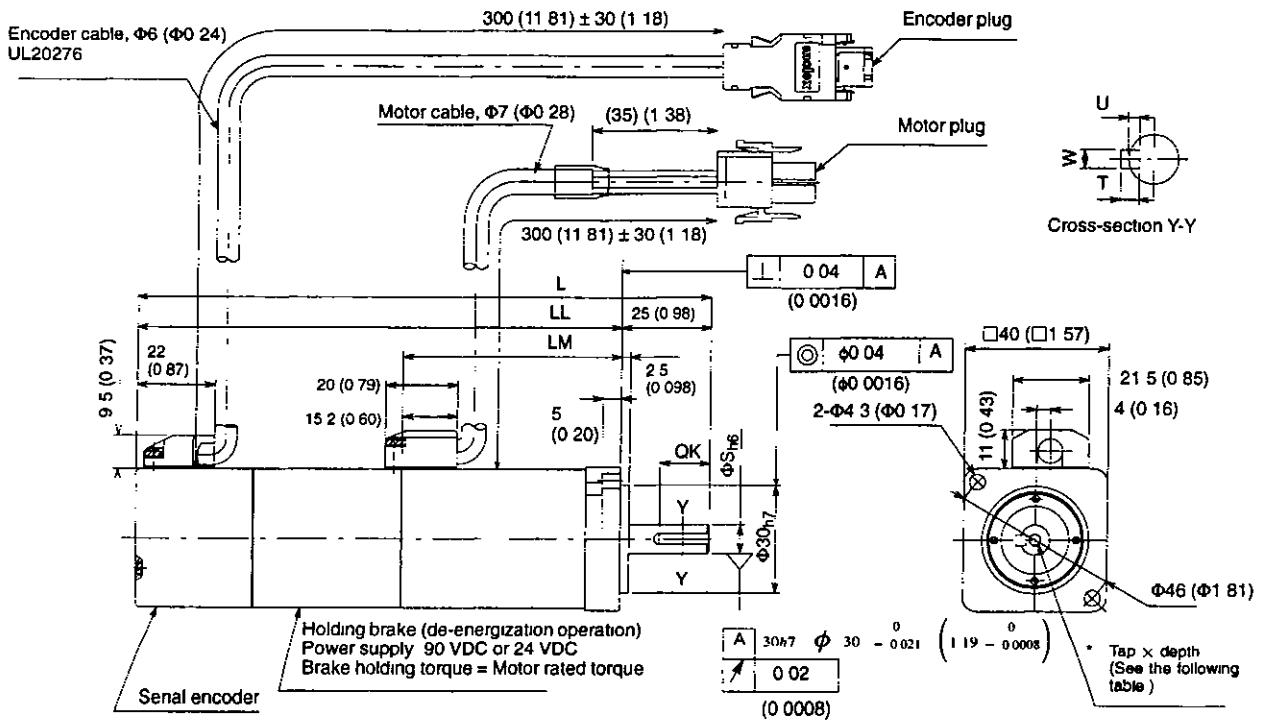

Units mm (in)

Model SGMAH-	L	LL	LM	S	* Tap × Depth	QK	U	W	T	Approx. Mass kg (lb)
A3□□A2□	126 0	101 0	36 5	6	No tap	No key				0.6 (1.32)
A3□□A4□	(4.96)	(3.98)	(1.44)	(0.24)		14	12	2	2	
A3□□A6□					M2.5 × 5L	(0.55)	(0.047)	(0.079)	(0.079)	
A5□□A2□	133 5	108 5	44 0	6	No tap	No key				0.7 (1.54)
A5□□A4□	(5.26)	(4.27)	(1.73)	(0.24)		14	12	2	2	
A5□□A6□					M2.5 × 5L	(0.55)	(0.047)	(0.079)	(0.079)	
01□□A2□	160 0	135 0	61 5	8	No tap	No key				0.8 (1.76)
01□□A4□	(6.30)	(5.31)	(2.42)	(0.31)		14	18	3	3	
01□□A6□					M3 × 6L	(0.55)	(0.071)	(0.12)	(0.12)	

• Dimensional Tolerances

Model SGMAH-	Shaft-end Dimensions mm (in)
	S
A3□□A2□ A3□□A4□ A3□□A6□	$6 - \begin{smallmatrix} 0 \\ -0.008 \end{smallmatrix} \left(0.24 - \begin{smallmatrix} 0 \\ -0.0003 \end{smallmatrix} \right)$
A5□□A2□ A5□□A4□ A5□□A6□	$6 - \begin{smallmatrix} 0 \\ -0.008 \end{smallmatrix} \left(0.24 - \begin{smallmatrix} 0 \\ -0.0003 \end{smallmatrix} \right)$
01□□A2□ 01□□A4□ 01□□A6□	$8 - \begin{smallmatrix} 0 \\ -0.009 \end{smallmatrix} \left(0.32 - \begin{smallmatrix} 0 \\ -0.0004 \end{smallmatrix} \right)$

SGMAH: 200 W, 400 W, 750 W With Brakes

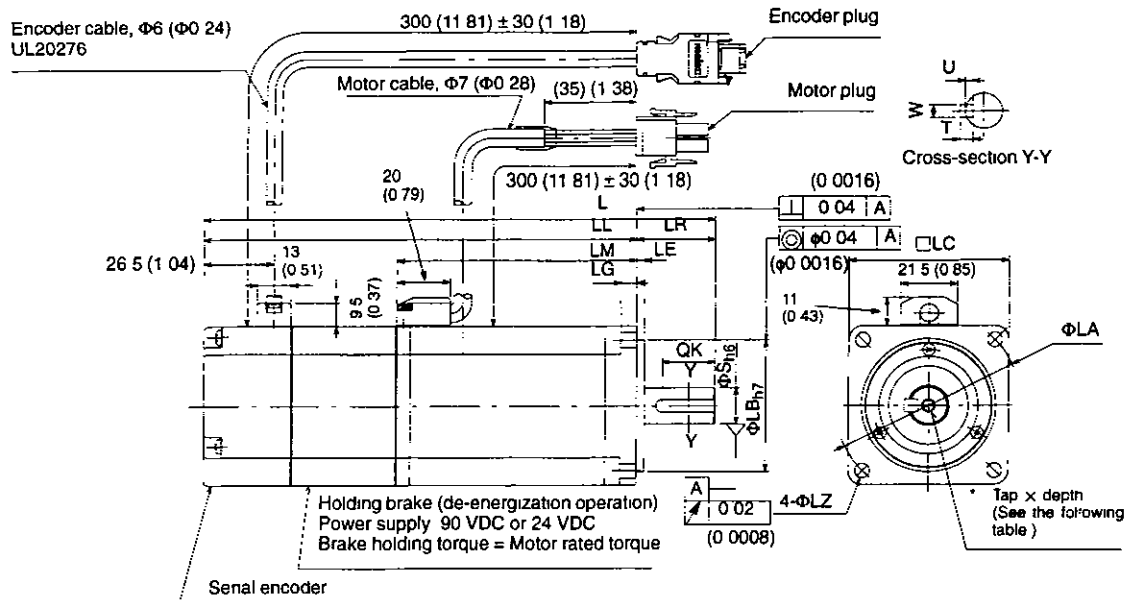

Units mm (in)

Model SGMAH-	L	LL	LM	LR	LE	LG	LC	LA	LZ	S	LB	* Tap × Depth	QK	U	W	T	Approx Mass kg (lb)
02□□A2□ 02□□A4□ 02□□A6□	166 (6.54)	136 (5.35)	62.5 (2.46)	30 (1.18)	3 (0.12)	6 (0.24)	60 (2.36)	70 (2.76)	55 (0.22)	14 (0.55)	50 (1.97)	No tap	No key				1.6 (3.53)
												M5 × 8L	20 (0.79)	3 (0.12)	5 (0.20)	5 (0.20)	
04A□A2□ 04A□A4□ 04A□A6□	194 (7.64)	164 (6.46)	90.5 (3.56)	30 (1.18)	3 (0.12)	6 (0.24)	60 (2.36)	70 (2.76)	55 (0.22)	14 (0.55)	50 (1.97)	No tap	No key				2.2 (4.85)
												M5 × 8L	20 (0.79)	3 (0.12)	5 (0.20)	5 (0.20)	
08A□A2□ 08A□A4□ 08A□A6□	229.5 (9.04)	189.5 (7.46)	111 (4.37)	40 (1.57)	3 (0.12)	8 (0.31)	80 (3.15)	90 (3.54)	7 (0.28)	16 (0.63)	70 (2.76)	No tap	No key				4.3 (9.48)
												M5 × 8L	30 (1.18)	3 (0.12)	5 (0.20)	5 (0.20)	

• Dimensional Tolerances

Model SGMAH-	Shaft-end Dimensions mm (in)	Flange Face Dimensions mm (in)
	S	LB
02□□A2□	14 - ⁰ / _{0.011} ; (0.56 - ⁰ / _{0.0004})	50 - ⁰ / _{0.025} (1.98 - ⁰ / _{0.0010})
02□□A4□		
02□□A6□		
04A□A2□	14 - ⁰ / _{0.011} (0.56 - ⁰ / _{0.0004})	50 - ⁰ / _{0.025} (1.98 - ⁰ / _{0.0010})
04A□A4□		
04A□A6□		
08A□A2□	16 - ⁰ / _{0.011} (0.64 - ⁰ / _{0.0004})	70 - ⁰ / _{0.030} (2.78 - ⁰ / _{0.0012})
08A□A4□		
08A□A6□		

SGMAH Servomotor and Encoder Lead Specifications

• Motor Plug

Standard Part



Plug 350779-1 (AMP)
Pin 350561-3 or 350690-3 (Nos 1 to 3)
Ground pin 770210-1 (No 4)

Connected to
Cap 350780-1
Socket 350570-3 or 350689-3

1	Phase U	Red
2	Phase V	White
3	Phase W	Blue
4	FG	Green/Yellow

With Brake



Plug 350715-1 (AMP)
Pin 350561-3 or 350690-3 (Except No 4)
Ground pin 770210-1 (No 4)

Connected to
Cap 350781-1
Socket 350570-3 or 350689-3

1	Phase U	Red
2	Phase V	White
3	Phase W	Blue
4	FG	Green/Yellow
5	Brake terminal	Red
6	Brake terminal	Black

• Servomotor Lead

Lead specifications AWG20, UL1828 or UL3534

• Encoder Plug

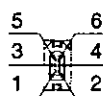

Plug 55102-0600 (Molex Japan Co., Ltd)

Connected to
Socket 54280-0600

Lead Specifications for 16-bit Serial Absolute Encoders

1	PG 5 V	Red
2	PG 0 V	Black
3	BAT	Orange
4	0BAT	White/Orange
5	PS	Light blue
6	/PS	White/Light blue

Lead Specifications for 13-bit Serial Incremental Encoders

1	PG 5 V	Red
2	PG 0 V	Black
3	-	-
4	-	-
5	PS	Light blue
6	/PS	White/Light blue

■ **Servomotors Without Brakes and With Gears**

Either standard backlash or low-backlash gears are available

SGMAH: 30 W, 50 W, 100 W Without Brakes and With Gears

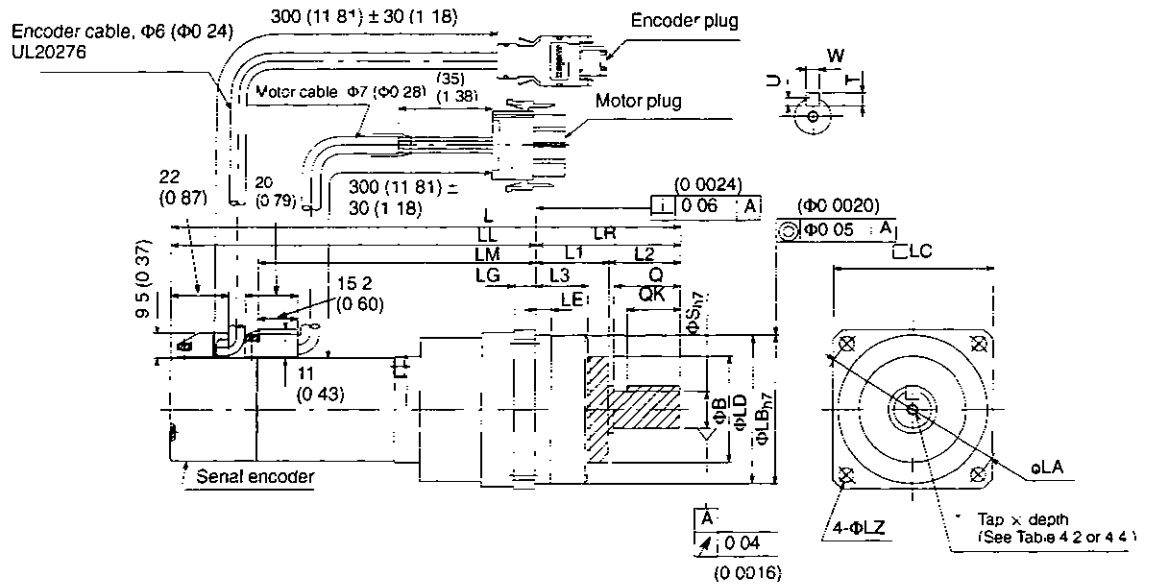

Table 4.1 Servomotors with Low-backlash Gears (L to LZ)

Units mm (in)

Model SGMAH-	Gear Ratio	L	LL	LM	LR	LE	LG	B	LD	LB	LC	LA	LZ
A3□□AG1□1	1/5	152.5 (6.00)	97.5 (3.84)	64.5 (2.54)	55 (2.17)	6 (0.24)	8 (0.31)	40 (1.57)	55.5 (2.19)	56 (2.20)	60 (2.36)	70 (2.76)	5.5 (0.22)
A3□□AG2□1	1/9	152.5 (6.00)	97.5 (3.84)	64.5 (2.54)	55 (2.17)	6 (0.24)	8 (0.31)	40 (1.57)	55.5 (2.19)	56 (2.20)	60 (2.36)	70 (2.76)	5.5 (0.22)
A3□□AGC□1	1/21	167.5 (6.59)	112.5 (4.43)	79.5 (3.13)	55 (2.17)	6 (0.24)	8 (0.31)	40 (1.57)	55.5 (2.19)	56 (2.20)	60 (2.36)	70 (2.76)	5.5 (0.22)
A3□□AG7□1	1/33	167.5 (6.59)	112.5 (4.43)	79.5 (3.13)	55 (2.17)	6 (0.24)	8 (0.31)	40 (1.57)	55.5 (2.19)	56 (2.20)	60 (2.36)	70 (2.76)	5.5 (0.22)
A5□□AG1□1	1/5	160 (6.30)	105 (4.13)	72.0 (2.83)	55 (2.17)	6 (0.24)	8 (0.31)	40 (1.57)	55.5 (2.19)	56 (2.20)	60 (2.36)	70 (2.76)	5.5 (0.22)
A5□□AG2□1	1/9	166 (6.54)	106 (4.17)	73.0 (2.87)	60 (2.36)	8 (0.31)	9 (0.35)	50 (1.97)	64.5 (2.54)	65 (2.56)	70 (2.76)	80 (3.15)	6.6 (0.26)
A5□□AGC□1	1/21	183 (7.20)	123 (4.84)	90.0 (3.54)	60 (2.36)	8 (0.31)	9 (0.35)	50 (1.97)	64.5 (2.54)	65 (2.56)	70 (2.76)	80 (3.15)	6.6 (0.26)

Model SGMAH-	Gear Ratio	L	LL	LM	LR	LE	LG	B	LD	LB	LC	LA	LZ
A5□□AG7□1	1/33	183 (7 20)	123 (4 84)	90 0 (3 54)	60 (2 36)	8 (0 31)	9 (0 35)	50 (1 97)	64 5 (2 54)	65 (2 56)	70 (2 76)	80 (3 15)	6 6 (0 26)
01□□AG1□1	1/5	183 5 (7 22)	123 5 (4 86)	90 5 (3 56)	60 (2 36)	8 (0 31)	9 (0 35)	50 (1 97)	64 5 (2 54)	65 (2 56)	70 (2 76)	80 (3 15)	6 6 (0 26)
01□□AGB□1	1/11	200 5 (7 89)	140 5 (5 53)	107 5 (4 23)	60 (2 36)	8 (0 31)	9 (0 35)	50 (1 97)	64 5 (2 54)	65 (2 56)	70 (2 76)	80 (3 15)	6 6 (0 26)
01□□AGC□1	1/21	223 5 (8 80)	149 5 (5 89)	116 5 (4 59)	74 (2 91)	10 (0 39)	10 (0 39)	60 (2 36)	83 (3 27)	85 (3 35)	90 (3 54)	105 (4 13)	9 (0 35)
01□□AG7□1	1/33	223 5 (8 80)	149 5 (5 89)	116 5 (4 59)	74 (2 91)	10 (0 39)	10 (0 39)	60 (2 36)	83 (3 27)	85 (3 35)	90 (3 54)	105 (4 13)	9 (0 35)

Table 4 2 Servomotors with Low-backlash Gears (L1 to T)

Units mm (in)

Model SGMAH-	L1	L2	L3	Q	S	*Tap × depth	QK	U	W	T	Approx. Mass kg (lb)
A3□□AG1□1	28 (1 10)	27 (1 06)	20 (0 79)	25 (0 98)	14 (0 55)	M4 × 8L	20 (0 79)	3 (0 12)	5 (0 20)	5 (0 20)	1 0 (2 21)
A3□□AG2□1	28 (1 10)	27 (1 06)	20 (0 79)	25 (0 98)	14 (0 55)	M4 × 8L	20 (0 79)	3 (0 12)	5 (0 20)	5 (0 20)	1 0 (2 21)
A3□□AGC□1	28 (1 10)	27 (1 06)	20 (0 79)	25 (0 98)	14 (0 55)	M4 × 8L	20 (0 79)	3 (0 12)	5 (0 20)	5 (0 20)	1 0 (2 21)
A3□□AG7□1	28 (1 10)	27 (1 06)	20 (0 79)	25 (0 98)	14 (0 55)	M4 × 8L	20 (0 79)	3 (0 12)	5 (0 20)	5 (0 20)	1 0 (2 21)
A5□□AG1□1	28 (1 10)	27 (1 06)	20 (0 79)	25 (0 98)	14 (0 55)	M4 × 8L	20 (0 79)	3 (0 12)	5 (0 20)	5 (0 20)	1 1 (2 43)
A5□□AG2□1	30 (1 18)	30 (1 18)	22 (0 87)	28 (1 10)	16 (0 63)	M4 × 8L	25 (0 98)	3 (0 12)	5 (0 20)	5 (0 20)	1 4 (3 09)
A5□□AGC□1	30 (1 18)	30 (1 18)	22 (0 87)	28 (1 10)	16 (0 63)	M4 × 8L	25 (0 98)	3 (0 12)	5 (0 20)	5 (0 20)	1 5 (3 31)
A5□□AG7□1	30 (1 18)	30 (1 18)	22 (0 87)	28 (1 10)	16 (0 63)	M4 × 8L	25 (0 98)	3 (0 12)	5 (0 20)	5 (0 20)	1 5 (3 31)
01□□AG1□1	30 (1 18)	30 (1 18)	22 (0 87)	28 (1 10)	16 (0 63)	M4 × 8L	25 (0 98)	3 (0 12)	5 (0 20)	5 (0 20)	1 5 (3 31)
01□□AGB□1	30 (1 18)	30 (1 18)	22 (0 87)	28 (1 10)	16 (0 63)	M4 × 8L	25 (0 98)	3 (0 12)	5 (0 20)	5 (0 20)	1 6 (3 53)
01□□AGC□1	36 (1 42)	38 (1 50)	26 (1 02)	36 (1 42)	20 (0 79)	M5 × 10L	32 (1 26)	3 5 (0 14)	6 (0 24)	6 (0 24)	2 7 (5 95)
01□□AG7□1	36 (1 42)	38 (1 50)	26 (1 02)	36 (1 42)	20 (0 79)	M5 × 10L	32 (1 26)	3 5 (0 14)	6 (0 24)	6 (0 24)	2 7 (5 95)

• Dimensional Tolerances

Model SGMAH-	Flange Face Dimensions mm (in)		Shaft-end Dimensions mm (in)	
	LB		S	
A3□□AG1□1	56	$^{0}_{-0.030} (2.22 - ^{0}_{0.0012})$	14	$^{0}_{-0.018} (0.56 - ^{0}_{0.0007})$
A3□□AG2□1	56	$^{0}_{-0.030} (2.22 - ^{0}_{0.0012})$	14	$^{0}_{-0.018} (0.56 - ^{0}_{0.0007})$
A3□□AGC□1	56	$^{0}_{-0.030} (2.22 - ^{0}_{0.0012})$	14	$^{0}_{-0.018} (0.56 - ^{0}_{0.0007})$
A3□□AG7□1	56	$^{0}_{-0.030} (2.22 - ^{0}_{0.0012})$	14	$^{0}_{-0.018} (0.56 - ^{0}_{0.0007})$



Servodrive Dimensional Drawings

4 1 1 SGMAH Servomotors

Model SGMAH-	Flange Face Dimensions mm (in)	Shaft-end Dimensions mm (in)
	LB	S
A5□□AG1□1	$56 - 0.030 \begin{pmatrix} 0 \\ 2.22 - 0.0012 \end{pmatrix}$	$14 - 0.018 \begin{pmatrix} 0 \\ 0.56 - 0.0007 \end{pmatrix}$
A5□□AG2□1	$65 - 0.030 \begin{pmatrix} 0 \\ 2.58 - 0.0012 \end{pmatrix}$	$16 - 0.018 \begin{pmatrix} 0 \\ 0.64 - 0.0007 \end{pmatrix}$
A5□□AGC□1	$65 - 0.030 \begin{pmatrix} 0 \\ 2.58 - 0.0012 \end{pmatrix}$	$16 - 0.018 \begin{pmatrix} 0 \\ 0.64 - 0.0007 \end{pmatrix}$
A5□□AG7□1	$65 - 0.030 \begin{pmatrix} 0 \\ 2.58 - 0.0012 \end{pmatrix}$	$16 - 0.018 \begin{pmatrix} 0 \\ 0.64 - 0.0007 \end{pmatrix}$
01□□AG1□1	$65 - 0.030 \begin{pmatrix} 0 \\ 2.58 - 0.0012 \end{pmatrix}$	$16 - 0.018 \begin{pmatrix} 0 \\ 0.64 - 0.0007 \end{pmatrix}$
01□□AGB□1	$65 - 0.030 \begin{pmatrix} 0 \\ 2.58 - 0.0012 \end{pmatrix}$	$16 - 0.018 \begin{pmatrix} 0 \\ 0.64 - 0.0007 \end{pmatrix}$
01□□AGC□1	$85 - 0.035 \begin{pmatrix} 0 \\ 3.37 - 0.0014 \end{pmatrix}$	$20 - 0.021 \begin{pmatrix} 0 \\ 0.79 - 0.0008 \end{pmatrix}$
01□□AG7□1	$85 - 0.035 \begin{pmatrix} 0 \\ 3.37 - 0.0014 \end{pmatrix}$	$20 - 0.021 \begin{pmatrix} 0 \\ 0.79 - 0.0008 \end{pmatrix}$

Table 4.3 Servomotors with Standard Backlash Gears (L to LZ) Units mm (in)

Model SGMAH-	Gear Ratio	L	LL	LM	LR	LE	LG	B	LD	LB	LC	LA	LZ
A3□□AJ1□1	1/5	156.5 (6.16)	101.5 (4.00)	68.5 (2.70)	55 (2.17)	4 (0.16)	8 (0.31)	20 (0.79)	55.5 (2.19)	56 (2.20)	60 (2.36)	70 (2.76)	5.5 (0.22)
A3□□AJ3□1	3/31	156.5 (6.16)	101.5 (4.00)	68.5 (2.70)	55 (2.17)	4 (0.16)	8 (0.31)	20 (0.79)	55.5 (2.19)	56 (2.20)	60 (2.36)	70 (2.76)	5.5 (0.22)
A3□□AJC□1	1/21	171.5 (6.75)	116.5 (4.59)	83.5 (3.29)	55 (2.17)	4 (0.16)	8 (0.31)	20 (0.79)	55.5 (2.19)	56 (2.20)	60 (2.36)	70 (2.76)	5.5 (0.22)
A3□□AJ7□1	1/33	171.5 (6.75)	116.5 (4.59)	83.5 (3.29)	55 (2.17)	4 (0.16)	8 (0.31)	20 (0.79)	55.5 (2.19)	56 (2.20)	60 (2.36)	70 (2.76)	5.5 (0.22)
A5□□AJ1□1	1/5	164 (6.46)	109 (4.29)	76.0 (2.99)	55 (2.17)	4 (0.16)	8 (0.31)	20 (0.79)	55.5 (2.19)	56 (2.20)	60 (2.36)	70 (2.76)	5.5 (0.22)
A5□□AJ3□1	3/31	174 (6.85)	114 (4.49)	81.0 (3.19)	60 (2.36)	4 (0.16)	9 (0.35)	25 (0.98)	63 (2.48)	65 (2.56)	70 (2.76)	80 (3.15)	6.6 (0.26)
A5□□AJC□1	1/21	191 (7.52)	131 (5.16)	98.0 (3.86)	60 (2.36)	4 (0.16)	9 (0.35)	25 (0.98)	63 (2.48)	65 (2.56)	70 (2.76)	80 (3.15)	6.6 (0.26)
A5□□AJ7□1	1/33	191 (7.52)	131 (5.16)	98.0 (3.86)	60 (2.36)	4 (0.16)	9 (0.35)	25 (0.98)	63 (2.48)	65 (2.56)	70 (2.76)	80 (3.15)	6.6 (0.26)
01□□AJ1□1	1/5	191.5 (7.54)	131.5 (5.18)	98.5 (3.88)	60 (2.36)	4 (0.16)	9 (0.35)	25 (0.98)	63 (2.48)	65 (2.56)	70 (2.76)	80 (3.15)	6.6 (0.26)
01□□AJ3□1	3/31	191.5 (7.54)	131.5 (5.18)	98.5 (3.88)	60 (2.36)	4 (0.16)	9 (0.35)	25 (0.98)	63 (2.48)	65 (2.56)	70 (2.76)	80 (3.15)	6.6 (0.26)
01□□AJC□1	1/21	227 (8.94)	153 (6.02)	120 (4.72)	74 (2.91)	4 (0.16)	10 (0.39)	32 (1.26)	83 (3.27)	85 (3.35)	90 (3.54)	105 (4.13)	9 (0.35)
01□□AJ7□1	1/33	227 (8.94)	153 (6.02)	120 (4.72)	74 (2.91)	4 (0.16)	10 (0.39)	32 (1.26)	83 (3.27)	85 (3.35)	90 (3.54)	105 (4.13)	9 (0.35)

Table 4 4 Servomotors with Standard Backlash Gears (L1 to T) Units (mm) (in)

Model SGMAH-	L1	L2	L3	Q	S	*Tap × depth	QK	U	W	T	Approx. Mass kg (lb)
A3□□AJ1□1	30 (1 18)	25 (0 98)	28 (1 10)	25 (0 98)	14 (0 55)	M4 × 8L	20 (0 79)	3 (0 12)	5 (0 20)	5 (0 20)	0 9 (1 98)
A3□□AJ3□1	30 (1 18)	25 (0 98)	28 (1 10)	25 (0 98)	14 (0 55)	M4 × 8L	20 (0 79)	3 (0 12)	5 (0 20)	5 (0 20)	0 9 (1 98)
A3□□AJC□1	30 (1 18)	25 (0 98)	28 (1 10)	25 (0 98)	14 (0 55)	M4 × 8L	20 (0 79)	3 (0 12)	5 (0 20)	5 (0 20)	1 0 (2 21)
A3□□AJ7□1	30 (1 18)	25 (0 98)	28 (1 10)	25 (0 98)	14 (0 55)	M4 × 8L	20 (0 79)	3 (0 12)	5 (0 20)	5 (0 20)	1 0 (2 21)
A5□□AJ1□1	30 (1 18)	25 (0 98)	28 (1 10)	25 (0 98)	14 (0 55)	M4 × 8L	20 (0 79)	3 (0 12)	5 (0 20)	5 (0 20)	1 0 (2 21)
A5□□AJ3□1	32 (1 26)	28 (1 10)	30 (1 18)	28 (1 10)	16 (0 63)	M4 × 8L	25 (0 98)	3 (0 12)	5 (0 20)	5 (0 20)	1 2 (2 65)
A5□□AJC□1	32 (1 26)	28 (1 10)	30 (1 18)	28 (1 10)	16 (0 63)	M4 × 8L	25 (0 98)	3 (0 12)	5 (0 20)	5 (0 20)	1 3 (2 87)
A5□□AJ7□1	32 (1 26)	28 (1 10)	30 (1 18)	28 (1 10)	16 (0 63)	M4 × 8L	25 (0 98)	3 (0 12)	5 (0 20)	5 (0 20)	1 3 (2 87)
01□□AJ1□1	32 (1 26)	28 (1 10)	30 (1 18)	28 (1 10)	16 (0 63)	M4 × 8L	25 (0 98)	3 (0 12)	5 (0 20)	5 (0 20)	1 3 (2 87)
01□□AJ3□1	32 (1 26)	28 (1 10)	30 (1 18)	28 (1 10)	16 (0 63)	M4 × 8L	25 (0 98)	3 (0 12)	5 (0 20)	5 (0 20)	1 3 (2 87)
01□□AJC□1	38 (1 50)	36 (1 42)	36 (1 42)	36 (1 42)	20 (0 79)	M5 × 10L	32 (1 26)	3 5 (0 14)	6 (0 24)	6 (0 24)	2 4 (5 29)
01□□AJ7□1	38 (1 50)	36 (1 42)	36 (1 42)	36 (1 42)	20 (0 79)	M5 × 10L	32 (1 26)	3 5 (0 14)	6 (0 24)	6 (0 24)	2 4 (5 29)

• Dimensional Tolerances

Model SGMAH-	Flange Face Dimensions mm (in)	Shaft-end Dimensions mm (in)
	LB	S
A3□□AJ1□1	$56 - \begin{smallmatrix} 0 \\ -0.030 \end{smallmatrix} \left(2.22 - \begin{smallmatrix} 0 \\ -0.0012 \end{smallmatrix} \right)$	$14 - \begin{smallmatrix} 0 \\ -0.018 \end{smallmatrix} \left(0.56 - \begin{smallmatrix} 0 \\ -0.0007 \end{smallmatrix} \right)$
A3□□AJ3□1	$56 - \begin{smallmatrix} 0 \\ -0.030 \end{smallmatrix} \left(2.22 - \begin{smallmatrix} 0 \\ -0.0012 \end{smallmatrix} \right)$	$14 - \begin{smallmatrix} 0 \\ -0.018 \end{smallmatrix} \left(0.56 - \begin{smallmatrix} 0 \\ -0.0007 \end{smallmatrix} \right)$
A3□□AJC□1	$56 - \begin{smallmatrix} 0 \\ -0.030 \end{smallmatrix} \left(2.22 - \begin{smallmatrix} 0 \\ -0.0012 \end{smallmatrix} \right)$	$14 - \begin{smallmatrix} 0 \\ -0.018 \end{smallmatrix} \left(0.56 - \begin{smallmatrix} 0 \\ -0.0007 \end{smallmatrix} \right)$
A3□□AJ7□1	$56 - \begin{smallmatrix} 0 \\ -0.030 \end{smallmatrix} \left(2.22 - \begin{smallmatrix} 0 \\ -0.0012 \end{smallmatrix} \right)$	$14 - \begin{smallmatrix} 0 \\ -0.018 \end{smallmatrix} \left(0.56 - \begin{smallmatrix} 0 \\ -0.0007 \end{smallmatrix} \right)$
A5□□AJ1□1	$56 - \begin{smallmatrix} 0 \\ -0.030 \end{smallmatrix} \left(2.22 - \begin{smallmatrix} 0 \\ -0.0012 \end{smallmatrix} \right)$	$14 - \begin{smallmatrix} 0 \\ -0.018 \end{smallmatrix} \left(0.56 - \begin{smallmatrix} 0 \\ -0.0007 \end{smallmatrix} \right)$
A5□□AJ3□1	$65 - \begin{smallmatrix} 0 \\ -0.030 \end{smallmatrix} \left(2.58 - \begin{smallmatrix} 0 \\ -0.0012 \end{smallmatrix} \right)$	$16 - \begin{smallmatrix} 0 \\ -0.018 \end{smallmatrix} \left(0.64 - \begin{smallmatrix} 0 \\ -0.0007 \end{smallmatrix} \right)$
A5□□AJC□1	$65 - \begin{smallmatrix} 0 \\ -0.030 \end{smallmatrix} \left(2.58 - \begin{smallmatrix} 0 \\ -0.0012 \end{smallmatrix} \right)$	$16 - \begin{smallmatrix} 0 \\ -0.018 \end{smallmatrix} \left(0.64 - \begin{smallmatrix} 0 \\ -0.0007 \end{smallmatrix} \right)$
A5□□AJ7□1	$65 - \begin{smallmatrix} 0 \\ -0.030 \end{smallmatrix} \left(2.58 - \begin{smallmatrix} 0 \\ -0.0012 \end{smallmatrix} \right)$	$16 - \begin{smallmatrix} 0 \\ -0.018 \end{smallmatrix} \left(0.64 - \begin{smallmatrix} 0 \\ -0.0007 \end{smallmatrix} \right)$
01□□AJ1□1	$65 - \begin{smallmatrix} 0 \\ -0.030 \end{smallmatrix} \left(2.58 - \begin{smallmatrix} 0 \\ -0.0012 \end{smallmatrix} \right)$	$16 - \begin{smallmatrix} 0 \\ -0.018 \end{smallmatrix} \left(0.64 - \begin{smallmatrix} 0 \\ -0.0007 \end{smallmatrix} \right)$
01□□AJ3□1	$65 - \begin{smallmatrix} 0 \\ -0.030 \end{smallmatrix} \left(2.58 - \begin{smallmatrix} 0 \\ -0.0012 \end{smallmatrix} \right)$	$16 - \begin{smallmatrix} 0 \\ -0.018 \end{smallmatrix} \left(0.64 - \begin{smallmatrix} 0 \\ -0.0007 \end{smallmatrix} \right)$

Model SGMAH-	Flange Face Dimensions mm (in)		Shaft-end Dimensions mm (in)	
	LB		S	
01□□AJC□1	85	$3.37 - 0.0035$	20	$0.79 - 0.0008$
01□□AJ7□1	85	$3.37 - 0.0035$	20	$0.79 - 0.0008$

SGMAH: 200 W, 400 W, 750 W Without Brakes and With Gears

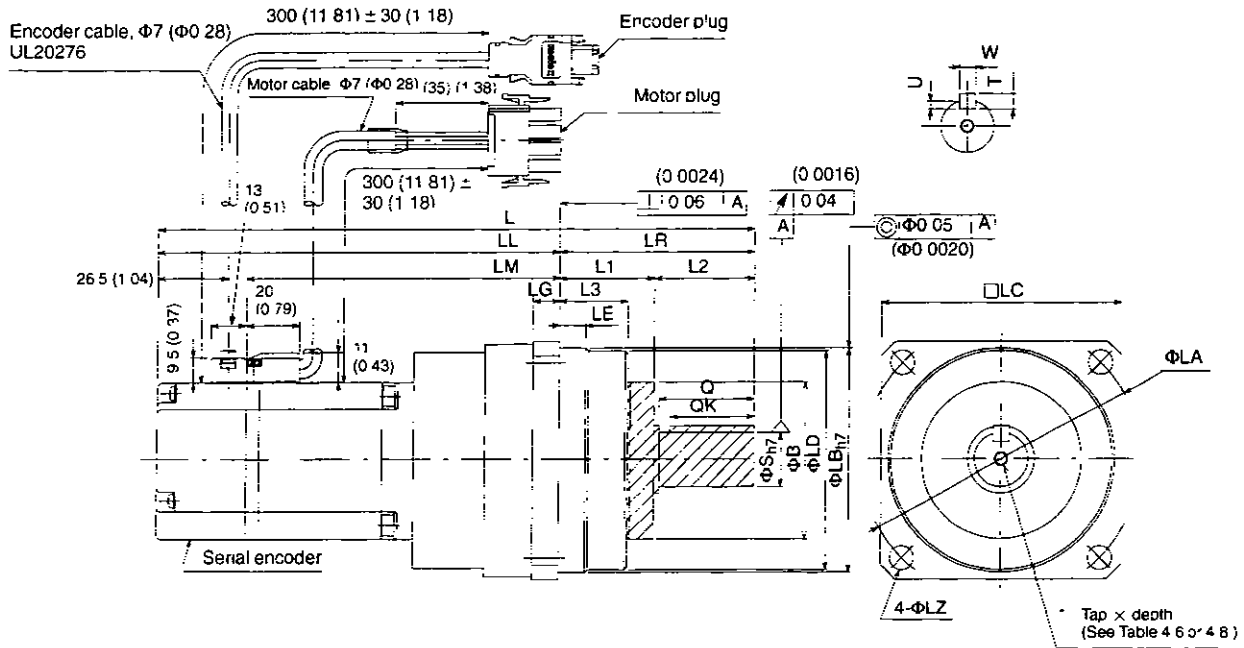

Table 4 5 Servomotors with Low-backlash Gears (L to LZ)

Units (mm) (in)

Model SGMAH-	Gear Ratio	L	LL	LM	LR	LE	LG	B	LD	LB	LC	LA	LZ
02□□AG1□1	1/5	208.5 (8.21)	134.5 (5.30)	100.5 (3.96)	74 (2.91)	10 (0.39)	10 (0.39)	60 (2.36)	83 (3.27)	85 (3.35)	90 (3.54)	105 (4.13)	9 (0.35)
02□□AGB□1	1/11	225.5 (8.88)	151.5 (5.96)	117.5 (4.63)	74 (2.91)	10 (0.39)	10 (0.39)	60 (2.36)	83 (3.27)	85 (3.35)	90 (3.54)	105 (4.13)	9 (0.35)
02□□AGC□1	1/21	243.5 (9.59)	159.5 (6.28)	125.5 (4.94)	84 (3.31)	12 (0.47)	12 (0.47)	70 (2.76)	96 (3.78)	100 (3.94)	105 (4.13)	120 (4.72)	9 (0.35)
02□□AG7□1	1/33	243.5 (9.59)	159.5 (6.28)	125.5 (4.94)	84 (3.31)	12 (0.47)	12 (0.47)	70 (2.76)	96 (3.78)	100 (3.94)	105 (4.13)	120 (4.72)	9 (0.35)
04A□AG1□1	1/5	236.5 (9.31)	162.5 (6.40)	128.5 (5.06)	74 (2.91)	10 (0.39)	10 (0.39)	60 (2.36)	83 (3.27)	85 (3.35)	90 (3.54)	105 (4.13)	9 (0.35)
04A□AGB□1	1/11	271.5 (10.69)	187.5 (7.38)	153.5 (6.04)	84 (3.31)	12 (0.47)	12 (0.47)	70 (2.76)	96 (3.78)	100 (3.94)	105 (4.13)	120 (4.72)	9 (0.35)
04A□AGC□1	1/21	300.5 (11.83)	195.5 (7.70)	161.5 (6.36)	105 (4.13)	14 (0.55)	13 (0.51)	90 (3.54)	112 (4.41)	115 (4.53)	120 (4.72)	135 (5.31)	11 (0.43)
04A□AG7□1	1/33	300.5 (11.83)	195.5 (7.70)	161.5 (6.36)	105 (4.13)	14 (0.55)	13 (0.51)	90 (3.54)	112 (4.41)	115 (4.53)	120 (4.72)	135 (5.31)	11 (0.43)
08A□AG1□1	1/5	271 (10.67)	187 (7.36)	153 (6.02)	84 (3.31)	12 (0.47)	12 (0.47)	70 (2.76)	96 (3.78)	100 (3.94)	105 (4.13)	120 (4.72)	9 (0.35)
08A□AGB□1	1/11	321 (12.64)	216 (8.50)	182 (7.17)	105 (4.13)	14 (0.55)	13 (0.51)	90 (3.54)	112 (4.41)	115 (4.53)	120 (4.72)	135 (5.31)	11 (0.43)

Model SGMAH-	Gear Ratio	L	LL	LM	LR	LE	LG	B	LD	LB	LC	LA	LZ
08A□AGC□1	1/21	365 (14 37)	223 (8 78)	189 (7 44)	142 (5 59)	16 (0 63)	15 (0 59)	107 (4 21)	134 (5 28)	140 (5 51)	145 (5 71)	165 (6 50)	14 (0 55)
08A□AG7□1	1/33	365 (14 37)	223 (8 78)	189 (7 44)	142 (5 59)	16 (0 63)	15 (0 59)	107 (4 21)	134 (5 28)	140 (5 51)	145 (5 71)	165 (6 50)	14 (0 55)

Table 4 6 Servomotors with Low-backlash Gears (L1 to T)

Units mm (in)

Model SGMAH-	L1	L2	L3	Q	S	*Tap × depth	QK	U	W	T	Approx. Mass kg (lb)
02□□AG1□1	36 (1 42)	38 (1 50)	26 (1 02)	36 (1 42)	20 (0 79)	M5 × 10L	32 (1 26)	3 5 (0 14)	6 (0 24)	6 (0 24)	3 2 (7 06)
02□□AGB□1	36 (1 42)	38 (1 50)	26 (1 02)	36 (1 42)	20 (0 79)	M5 × 10L	32 (1 26)	3 5 (0 14)	6 (0 24)	6 (0 24)	3 3 (7 28)
02□□AGC□1	40 (1 57)	44 (1 73)	29 (1 14)	42 (1 65)	25 (0 98)	M6 × 12L	36 (1 42)	4 (0 16)	8 (0 31)	7 (0 28)	4 5 (9 92)
02□□AG7□1	40 (1 57)	44 (1 73)	29 (1 14)	42 (1 65)	25 (0 98)	M6 × 12L	36 (1 42)	4 (0 16)	8 (0 31)	7 (0 28)	4 5 (9 92)
04A□AG1□1	36 (1 42)	38 (1 50)	26 (1 02)	36 (1 42)	20 (0 79)	M5 × 10L	32 (1 26)	3 5 (0 14)	6 (0 24)	6 (0 24)	3 8 (8 38)
04A□AGB□1	40 (1 57)	44 (1 73)	29 (1 14)	42 (1 65)	25 (0 98)	M6 × 12L	36 (1 42)	4 (0 16)	8 (0 31)	7 (0 28)	5 1 (11 2)
04A□AGC□1	45 (1 77)	60 (2 36)	33 (1 30)	58 (2 28)	32 (1 26)	M8 × 16L	50 (1 97)	5 (0 20)	10 (0 39)	8 (0 31)	7 0 (15 4)
04A□AG7□1	45 (1 77)	60 (2 36)	33 (1 30)	58 (2 28)	32 (1 26)	M8 × 16L	50 (1 97)	5 (0 20)	10 (0 39)	8 (0 31)	7 0 (15 4)
08A□AG1□1	40 (1 57)	44 (1 73)	29 (1 14)	42 (1 65)	25 (0 98)	M6 × 12L	36 (1 42)	4 (0 16)	8 (0 31)	7 (0 28)	6 5 (14 3)
08A□AGB□1	45 (1 77)	60 (2 36)	33 (1 30)	58 (2 28)	32 (1 26)	M8 × 16L	50 (1 97)	5 (0 20)	10 (0 39)	8 (0 31)	8 7 (19 2)
08A□AGC□1	57 (2 24)	85 (3 35)	42 (1 65)	82 (3 23)	40 (1 57)	M10 × 20L	70 (2 76)	5 (0 20)	12 (0 47)	8 (0 31)	13 1 (28 9)
08A□AG7□1	57 (2 24)	85 (3 35)	42 (1 65)	82 (3 23)	40 (1 57)	M10 × 20L	70 (2 76)	5 (0 20)	12 (0 47)	8 (0 31)	13 1 (28 9)

• Dimensional Tolerances

Model SGMAH-	Flange Face Dimensions mm (in)		Shaft-end Dimensions mm (in)	
	LB		S	
02□□AG1□1	85	$0_{-0.035}^0$ (3 37 - $0_{-0.0014}^0$)	20	$0_{-0.021}^0$ (0 79 - $0_{-0.0008}^0$)
02□□AGB□1	85	$0_{-0.035}^0$ (3 37 - $0_{-0.0014}^0$)	20	$0_{-0.021}^0$ (0 79 - $0_{-0.0008}^0$)
02□□AGC□1	100	$0_{-0.035}^0$ (3 97 - $0_{-0.0014}^0$)	25	$0_{-0.021}^0$ (0 99 - $0_{-0.0008}^0$)
02□□AG7□1	100	$0_{-0.035}^0$ (3 97 - $0_{-0.0014}^0$)	25	$0_{-0.021}^0$ (0 99 - $0_{-0.0008}^0$)
04A□AG1□1	85	$0_{-0.035}^0$ (3 37 - $0_{-0.0014}^0$)	20	$0_{-0.021}^0$ (0 79 - $0_{-0.0008}^0$)
04A□AGB□1	100	$0_{-0.035}^0$ (3 97 - $0_{-0.0014}^0$)	25	$0_{-0.021}^0$ (0 99 - $0_{-0.0008}^0$)

Servodrive Dimensional Drawings

4 1 1 SGMAH Servomotors

Model SGMAH-	Flange Face Dimensions mm (in)		Shaft-end Dimensions mm (in)	
	LB		S	
04A□AGC□1	115 ⁰ _{-0.035}	(4.57 ⁰ _{-0.0014})	32 ⁰ _{-0.025}	(1.27 ⁰ _{-0.0010})
04A□AG7□1	115 ⁰ _{-0.035}	(4.57 ⁰ _{-0.0014})	32 ⁰ _{-0.025}	(1.27 ⁰ _{-0.0010})
08A□AG1□1	100 ⁰ _{-0.035}	(3.97 ⁰ _{-0.0014})	25 ⁰ _{-0.021}	(0.99 ⁰ _{-0.0008})
08A□AGB□1	115 ⁰ _{-0.035}	(4.57 ⁰ _{-0.0014})	32 ⁰ _{-0.025}	(1.27 ⁰ _{-0.0010})
08A□AGC□1	140 ⁰ _{-0.040}	(5.56 ⁰ _{-0.0016})	40 ⁰ _{-0.025}	(1.59 ⁰ _{-0.0010})
08A□AG7□1	140 ⁰ _{-0.040}	(5.56 ⁰ _{-0.0016})	40 ⁰ _{-0.025}	(1.59 ⁰ _{-0.0010})

Table 4 7 Servomotors with Standard Backlash Gears (L to LZ) Units mm (in)

Model SGMAH-	Gear Ratio	L	LL	LM	LR	LE	LG	B	LD	LB	LC	LA	LZ
02□□AJ1□1	1/5	212 (8.35)	138 (5.43)	104 (4.09)	74 (2.91)	4 (0.16)	10 (0.39)	32 (1.26)	83 (3.27)	85 (3.35)	90 (3.54)	105 (4.13)	9 (0.35)
02□□AJ3□1	3/31	212 (8.35)	138 (5.43)	104 (4.09)	74 (2.91)	4 (0.16)	10 (0.39)	32 (1.26)	83 (3.27)	85 (3.35)	90 (3.54)	105 (4.13)	9 (0.35)
02□□AJC□1	1/21	249.5 (9.82)	165.5 (6.52)	131.5 (5.18)	84 (3.31)	4 (0.16)	12 (0.47)	40 (1.57)	98 (3.86)	100 (3.94)	105 (4.13)	120 (4.72)	9 (0.35)
02□□AJ7□1	1/33	249.5 (9.82)	165.5 (6.52)	131.5 (5.18)	84 (3.31)	4 (0.16)	12 (0.47)	40 (1.57)	98 (3.86)	100 (3.94)	105 (4.13)	120 (4.72)	9 (0.35)
04A□AJ1□1	1/5	240 (9.45)	166 (6.54)	132 (5.20)	74 (2.91)	4 (0.16)	10 (0.39)	32 (1.26)	83 (3.27)	85 (3.35)	90 (3.54)	105 (4.13)	9 (0.35)
04A□AJ3□1	3/31	256.5 (10.10)	172.5 (6.79)	138.5 (5.45)	84 (3.31)	4 (0.16)	12 (0.47)	40 (1.57)	98 (3.86)	100 (3.94)	105 (4.13)	120 (4.72)	9 (0.35)
04A□AJC□1	1/21	305.5 (12.03)	200.5 (7.89)	166.5 (6.56)	105 (4.13)	5 (0.20)	13 (0.51)	50 (1.97)	112 (4.41)	115 (4.53)	120 (4.72)	135 (5.31)	11 (0.43)
04A□AJ7□1	1/33	305.5 (12.03)	200.5 (7.89)	166.5 (6.56)	105 (4.13)	5 (0.20)	13 (0.51)	50 (1.97)	112 (4.41)	115 (4.53)	120 (4.72)	135 (5.31)	11 (0.43)
08A□AJ1□1	1/5	277 (10.91)	193 (7.60)	159 (6.26)	84 (3.31)	4 (0.16)	12 (0.47)	40 (1.57)	98 (3.86)	100 (3.94)	105 (4.13)	120 (4.72)	9 (0.35)
08A□AJ3□1	3/31	301 (11.85)	196 (7.72)	162 (6.38)	105 (4.13)	5 (0.20)	13 (0.51)	50 (1.97)	112 (4.41)	115 (4.53)	120 (4.72)	135 (5.31)	11 (0.43)
08A□AJC□1	1/21	330 (12.99)	223 (8.78)	189 (7.44)	107 (4.21)	10 (0.39)	15 (0.59)	107 (4.21)	134 (5.28)	140 (5.51)	145 (5.71)	165 (6.50)	14 (0.55)
08A□AJ7□1	1/33	330 (12.99)	223 (8.78)	189 (7.44)	107 (4.21)	10 (0.39)	15 (0.59)	107 (4.21)	134 (5.28)	140 (5.51)	145 (5.71)	165 (6.50)	14 (0.55)

Table 4.8 Servomotors with Standard Backlash Gears (L1 to T) Units mm (in)

Model SGMAH-	L1	L2	L3	Q	S	*Tap × depth	QK	U	W	T	Approx. Mass kg (lb)
02□□AJ1□1	38 (1 50)	36 (1 42)	36 (1 42)	36 (1 42)	20 (0 79)	M5 × 10L	32 (1 26)	3 5 (0 14)	6 (0 24)	6 (0 24)	2 8 (6 17)
02□□AJ3□1	38 (1 50)	36 (1 42)	36 (1 42)	36 (1 42)	20 (0 79)	M5 × 10L	32 (1 26)	3 5 (0 14)	6 (0 24)	6 (0 24)	2 8 (6 17)
02□□AJC□1	42 (1 65)	42 (1 65)	40 (1 57)	42 (1 65)	25 (0 98)	M6 × 12L	36 (1 42)	4 (0 16)	8 (0 31)	7 (0 28)	4 2 (9 26)
02□□AJ7□1	42 (1 65)	42 (1 65)	40 (1 57)	42 (1 65)	25 (0 98)	M6 × 12L	36 (1 42)	4 (0 16)	8 (0 31)	7 (0 28)	4 2 (9 26)
04A□AJ1□1	38 (1 50)	36 (1 42)	36 (1 42)	36 (1 42)	20 (0 79)	M5 × 10L	32 (1 26)	3 5 (0 14)	6 (0 24)	6 (0 24)	3 4 (7 50)
04A□AJ3□1	42 (1 65)	42 (1 65)	40 (1 57)	42 (1 65)	25 (0 98)	M6 × 12L	36 (1 42)	4 (0 16)	8 (0 31)	7 (0 28)	4 3 (9 48)
04A□AJC□1	47 (1 85)	58 (2 28)	45 (1 77)	58 (2 28)	32 (1 26)	M8 × 16L	50 (1 97)	5 (0 20)	10 (0 39)	8 (0 31)	6 4 (14 1)
04A□AJ7□1	47 (1 85)	58 (2 28)	45 (1 77)	58 (2 28)	32 (1 26)	M8 × 16L	50 (1 97)	5 (0 20)	10 (0 39)	8 (0 31)	6 4 (14 1)
08A□AJ1□1	42 (1 65)	42 (1 65)	40 (1 57)	42 (1 65)	25 (0 98)	M6 × 12L	36 (1 42)	4 (0 16)	8 (0 31)	7 (0 28)	6 0 (13 2)
08A□AJ3□1	47 (1 85)	58 (2 28)	45 (1 77)	58 (2 28)	32 (1 26)	M8 × 16L	50 (1 97)	5 (0 20)	10 (0 39)	8 (0 31)	7 5 (16 5)
08A□AJC□1	44 (1 73)	63 (2 48)	42 (1 65)	60 (2 36)	40 (1 57)	M10 × 20L	45 (1 77)	5 (0 20)	12 (0 47)	8 (0 31)	12 4 (27 3)
08A□AJ7□1	44 (1 73)	63 (2 48)	42 (1 65)	60 (2 36)	40 (1 57)	M10 × 20L	45 (1 77)	5 (0 20)	12 (0 47)	8 (0 31)	12 4 (27 3)

• Dimensional Tolerances

Model SGMAH-	Flange Face Dimensions mm (in)	Shaft-end Dimensions mm (in)
	LB	S
02□□AJ1□1	$85 - 0_{-0.035} \left(3.37 - 0_{-0.0014} \right)$	$20 - 0_{-0.021} \left(0.79 - 0_{-0.0008} \right)$
02□□AJ3□1	$85 - 0_{-0.035} \left(3.37 - 0_{-0.0014} \right)$	$20 - 0_{-0.021} \left(0.79 - 0_{-0.0008} \right)$
02□□AJC□1	$100 - 0_{-0.035} \left(3.97 - 0_{-0.0014} \right)$	$25 - 0_{-0.021} \left(0.99 - 0_{-0.0008} \right)$
02□□AJ7□1	$100 - 0_{-0.035} \left(3.97 - 0_{-0.0014} \right)$	$25 - 0_{-0.021} \left(0.99 - 0_{-0.0008} \right)$
04A□AJ1□1	$85 - 0_{-0.035} \left(3.37 - 0_{-0.0014} \right)$	$20 - 0_{-0.021} \left(0.79 - 0_{-0.0008} \right)$
04A□AJ3□1	$100 - 0_{-0.035} \left(3.97 - 0_{-0.0014} \right)$	$25 - 0_{-0.021} \left(0.99 - 0_{-0.0008} \right)$
04A□AJC□1	$115 - 0_{-0.035} \left(4.57 - 0_{-0.0014} \right)$	$32 - 0_{-0.025} \left(1.27 - 0_{-0.0010} \right)$
04A□AJ7□1	$115 - 0_{-0.035} \left(4.57 - 0_{-0.0014} \right)$	$32 - 0_{-0.025} \left(1.27 - 0_{-0.0010} \right)$
08A□AJ1□1	$100 - 0_{-0.035} \left(3.97 - 0_{-0.0014} \right)$	$25 - 0_{-0.021} \left(0.99 - 0_{-0.0008} \right)$
08A□AJ3□1	$115 - 0_{-0.035} \left(4.57 - 0_{-0.0014} \right)$	$32 - 0_{-0.025} \left(1.27 - 0_{-0.0010} \right)$

Servodrive Dimensional Drawings

4 1 1 SGMAH Servomotors

Model SGMAH-	Flange Face Dimensions mm (in)	Shaft-end Dimensions mm (in)
	LB	S
08A□AJC□1	140 $^{0}_{-0.040}$ (5.56 $^{0}_{-0.0016}$)	40 $^{0}_{-0.025}$ (1.59 $^{0}_{-0.0010}$)
08A□AJ7□1	140 $^{0}_{-0.040}$ (5.56 $^{0}_{-0.0016}$)	40 $^{0}_{-0.025}$ (1.59 $^{0}_{-0.0010}$)

Servomotor and Encoder Lead Specifications

The Servomotor and Encoder lead specifications are the same as those for standard Servomotors

■ Servomotors With Brakes and Gears

Either standard backlash or low-backlash gears are available

SGMAH: 30 W, 50 W, 100 W With Brakes and Gears

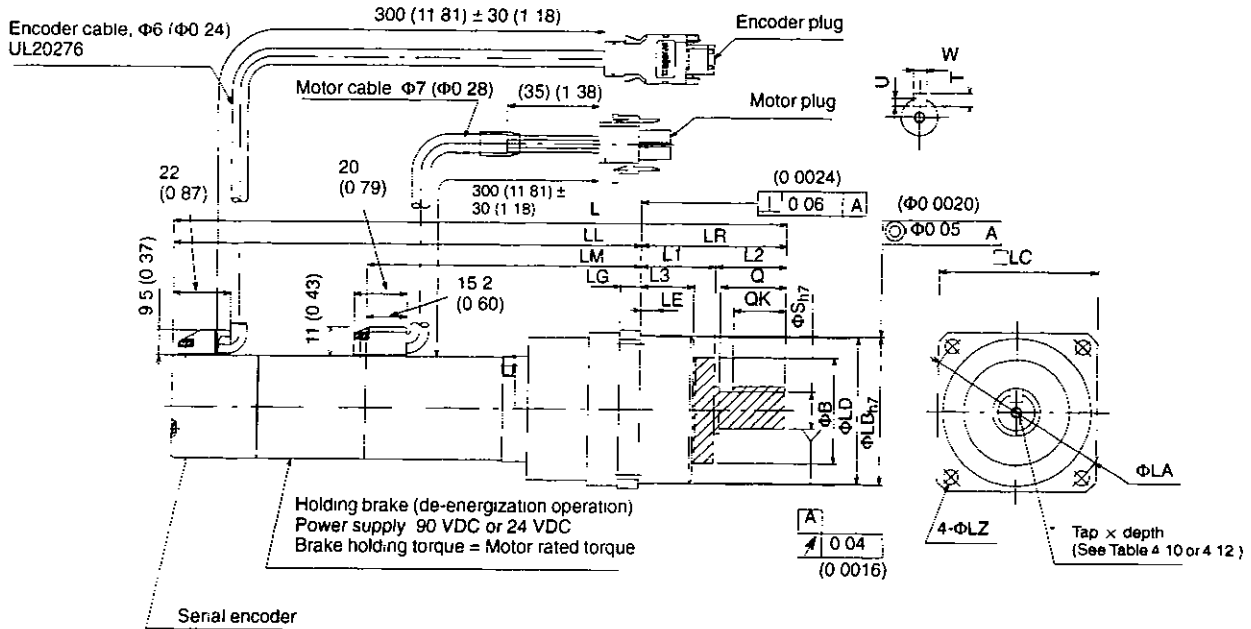

Table 4 9 Servomotors with Low-backlash Gears (L to LZ)

Units mm (in)

Model SGMAH-	Gear Ratio	L	LL	LM	LR	LE	LG	B	LD	LB	LC	LA	LZ
A3□□AG1□□	1/5	184.5 (7.26)	129.5 (5.10)	64.5 (2.54)	55 (2.17)	6 (0.24)	8 (0.31)	40 (1.57)	55.5 (2.19)	56 (2.20)	60 (2.36)	70 (2.76)	5.5 (0.22)
A3□□AG2□□	1/9	184.5 (7.26)	129.5 (5.10)	64.5 (2.54)	55 (2.17)	6 (0.24)	8 (0.31)	40 (1.57)	55.5 (2.19)	56 (2.20)	60 (2.36)	70 (2.76)	5.5 (0.22)
A3□□AGC□□	1/21	199.5 (7.85)	144.5 (5.69)	79.5 (3.13)	55 (2.17)	6 (0.24)	8 (0.31)	40 (1.57)	55.5 (2.19)	56 (2.20)	60 (2.36)	70 (2.76)	5.5 (0.22)
A3□□AG7□□	1/33	199.5 (7.85)	144.5 (5.69)	79.5 (3.13)	55 (2.17)	6 (0.24)	8 (0.31)	40 (1.57)	55.5 (2.19)	56 (2.20)	60 (2.36)	70 (2.76)	5.5 (0.22)
A5□□AG1□□	1/5	192 (7.56)	137 (5.39)	72.0 (2.83)	55 (2.17)	6 (0.24)	8 (0.31)	40 (1.57)	55.5 (2.19)	56 (2.20)	60 (2.36)	70 (2.76)	5.5 (0.22)
A5□□AG2□□	1/9	198 (7.80)	138 (5.43)	73.0 (2.87)	60 (2.36)	8 (0.31)	9 (0.35)	50 (1.97)	64.5 (2.54)	65 (2.56)	70 (2.76)	80 (3.15)	6.6 (0.26)
A5□□AGC□□	1/21	215 (8.46)	155 (6.10)	90.0 (3.54)	60 (2.36)	8 (0.31)	9 (0.35)	50 (1.97)	64.5 (2.54)	65 (2.56)	70 (2.76)	80 (3.15)	6.6 (0.26)
A5□□AG7□□	1/33	215 (8.46)	155 (6.10)	90.0 (3.54)	60 (2.36)	8 (0.31)	9 (0.35)	50 (1.97)	64.5 (2.54)	65 (2.56)	70 (2.76)	80 (3.15)	6.6 (0.26)
A5□□AG1□□	1/5	224.5 (8.84)	164.5 (6.48)	90.0 (3.54)	60 (2.36)	8 (0.31)	9 (0.35)	50 (1.97)	64.5 (2.54)	65 (2.56)	70 (2.76)	80 (3.15)	6.6 (0.26)
01□□AGB□□	1/11	241.5 (9.51)	181.5 (7.15)	107.5 (4.23)	60 (2.36)	8 (0.31)	9 (0.35)	50 (1.97)	64.5 (2.54)	65 (2.56)	70 (2.76)	80 (3.15)	6.6 (0.26)

Model SGMAH-	Gear Ratio	L	LL	LM	LR	LE	LG	B	LD	LB	LC	LA	LZ
01□□AGC□□	1/21	264.5 (10.41)	190.5 (7.50)	116.5 (4.59)	74 (2.91)	10 (0.39)	10 (0.39)	60 (2.36)	83 (3.27)	85 (3.35)	90 (3.54)	105 (4.13)	9 (0.35)
01□□AG7□□	1/33	264.5 (10.41)	190.5 (7.50)	116.5 (4.59)	74 (2.91)	10 (0.39)	10 (0.39)	60 (2.36)	83 (3.27)	85 (3.35)	90 (3.54)	105 (4.13)	9 (0.35)

Table 4.10 Servomotors with Low-backlash Gears (L1 to T)

Units mm (in)

Model SGMAH-	L1	L2	L3	Q	S	*Tap × depth	QK	U	W	T	Approx. Mass kg (lb)
A3□□AG1□□	28 (1.10)	27 (1.06)	20 (0.79)	25 (0.98)	14 (0.55)	M4 × 8L	20 (0.79)	3 (0.12)	5 (0.20)	5 (0.20)	1.3 (2.87)
A3□□AG2□□	28 (1.10)	27 (1.06)	20 (0.79)	25 (0.98)	14 (0.55)	M4 × 8L	20 (0.79)	3 (0.12)	5 (0.20)	5 (0.20)	1.3 (2.87)
A3□□AGC□□	28 (1.10)	27 (1.06)	20 (0.79)	25 (0.98)	14 (0.55)	M4 × 8L	20 (0.79)	3 (0.12)	5 (0.20)	5 (0.20)	1.3 (2.87)
A3□□AG7□□	28 (1.10)	27 (1.06)	20 (0.79)	25 (0.98)	14 (0.55)	M4 × 8L	20 (0.79)	3 (0.12)	5 (0.20)	5 (0.20)	1.3 (2.87)
A5□□AG1□□	28 (1.10)	27 (1.06)	20 (0.79)	25 (0.98)	14 (0.55)	M4 × 8L	20 (0.79)	3 (0.12)	5 (0.20)	5 (0.20)	1.4 (3.09)
A5□□AG2□□	30 (1.18)	30 (1.18)	22 (0.87)	28 (1.10)	16 (0.63)	M4 × 8L	25 (0.98)	3 (0.12)	5 (0.20)	5 (0.20)	1.7 (3.75)
A5□□AGC□□	30 (1.18)	30 (1.18)	22 (0.87)	28 (1.10)	16 (0.63)	M4 × 8L	25 (0.98)	3 (0.12)	5 (0.20)	5 (0.20)	2.0 (4.41)
A5□□AG7□□	30 (1.18)	30 (1.18)	22 (0.87)	28 (1.10)	16 (0.63)	M4 × 8L	25 (0.98)	3 (0.12)	5 (0.20)	5 (0.20)	2.0 (4.41)
A5□□AG1□□	30 (1.18)	30 (1.18)	22 (0.87)	28 (1.10)	16 (0.63)	M4 × 8L	25 (0.98)	3 (0.12)	5 (0.20)	5 (0.20)	1.8 (3.97)
01□□AGB□□	30 (1.18)	30 (1.18)	22 (0.87)	28 (1.10)	16 (0.63)	M4 × 8L	25 (0.98)	3 (0.12)	5 (0.20)	5 (0.20)	1.9 (4.19)
01□□AGC□□	36 (1.42)	38 (1.50)	26 (1.02)	36 (1.42)	20 (0.79)	M5 × 10L	32 (1.26)	3.5 (0.14)	6 (0.24)	6 (0.24)	3.0 (6.61)
01□□AG7□□	36 (1.42)	38 (1.50)	26 (1.02)	36 (1.42)	20 (0.79)	M5 × 10L	32 (1.26)	3.5 (0.14)	6 (0.24)	6 (0.24)	3.0 (6.61)

• Dimensional Tolerances

Model SGMAH-	Flange Face Dimensions mm (in)		Shaft-end Dimensions mm (in)	
	LB		S	
A3□□AG1□□	56 ⁰ _{-0.030}	(2.22 ⁰ _{-0.0012})	14 ⁰ _{-0.018}	(0.56 ⁰ _{-0.0007})
A3□□AG2□□	56 ⁰ _{-0.030}	(2.22 ⁰ _{-0.0012})	14 ⁰ _{-0.018}	(0.56 ⁰ _{-0.0007})
A3□□AGC□□	56 ⁰ _{-0.030}	(2.22 ⁰ _{-0.0012})	14 ⁰ _{-0.018}	(0.56 ⁰ _{-0.0007})
A3□□AG7□□	56 ⁰ _{-0.030}	(2.22 ⁰ _{-0.0012})	14 ⁰ _{-0.018}	(0.56 ⁰ _{-0.0007})
A5□□AG1□□	56 ⁰ _{-0.030}	(2.22 ⁰ _{-0.0012})	14 ⁰ _{-0.018}	(0.56 ⁰ _{-0.0007})
A5□□AG2□□	65 ⁰ _{-0.030}	(2.58 ⁰ _{-0.0012})	16 ⁰ _{-0.018}	(0.64 ⁰ _{-0.0007})
A5□□AGC□□	65 ⁰ _{-0.030}	(2.58 ⁰ _{-0.0012})	16 ⁰ _{-0.018}	(0.64 ⁰ _{-0.0007})

Model SGMAH-	Flange Face Dimensions mm (in)		Shaft-end Dimensions mm (in)	
	LB		S	
A5□□AG7□□	65	$2.58 - 0.0012$	16	$0.64 - 0.0007$
A5□□AG1□□	65	$2.58 - 0.0012$	16	$0.64 - 0.0007$
01□□AGB□□	65	$2.58 - 0.0012$	16	$0.64 - 0.0007$
01□□AGC□□	85	$3.37 - 0.0014$	20	$0.79 - 0.0008$
01□□AG7□□	85	$3.37 - 0.0014$	20	$0.79 - 0.0008$

Table 4.11 Servomotors with Standard Backlash Gears (L to LZ) Units mm (in)

Model SGMAH-	Gear Ratio	L	LL	LM	LR	LE	LG	B	LD	LB	LC	LA	LZ
A3□□AJ1□□	1/5	188.5 (7.42)	133.5 (5.26)	68.5 (2.70)	55 (2.17)	4 (0.16)	8 (0.31)	20 (0.79)	55.5 (2.19)	56 (2.20)	60 (2.36)	70 (2.76)	5.5 (0.22)
A3□□AJ3□□	3/31	188.5 (7.42)	133.5 (5.26)	68.5 (2.70)	55 (2.17)	4 (0.16)	8 (0.31)	20 (0.79)	55.5 (2.19)	56 (2.20)	60 (2.36)	70 (2.76)	5.5 (0.22)
A3□□AJC□□	1/21	203.5 (8.01)	148.5 (5.85)	83.5 (3.29)	55 (2.17)	4 (0.16)	8 (0.31)	20 (0.79)	55.5 (2.19)	56 (2.20)	60 (2.36)	70 (2.76)	5.5 (0.22)
A3□□AJ7□□	1/33	203.5 (8.01)	148.5 (5.85)	83.5 (3.29)	55 (2.17)	4 (0.16)	8 (0.31)	20 (0.79)	55.5 (2.19)	56 (2.20)	60 (2.36)	70 (2.76)	5.5 (0.22)
A5□□AJ1□□	1/5	196 (7.72)	141 (5.55)	76.0 (2.99)	55 (2.17)	4 (0.16)	8 (0.31)	20 (0.79)	55.5 (2.19)	56 (2.20)	60 (2.36)	70 (2.76)	5.5 (0.22)
A5□□AJ3□□	3/31	206 (8.11)	146 (5.75)	81.0 (3.19)	60 (2.36)	4 (0.16)	9 (0.35)	25 (0.98)	63 (2.48)	65 (2.56)	70 (2.76)	80 (3.15)	6.6 (0.26)
A5□□AJC□□	1/21	223 (8.78)	163 (6.42)	98.0 (3.86)	60 (2.36)	4 (0.16)	9 (0.35)	25 (0.98)	63 (2.48)	65 (2.56)	70 (2.76)	80 (3.15)	6.6 (0.26)
A5□□AJ7□□	1/33	223 (8.78)	163 (6.42)	98.0 (3.86)	60 (2.36)	4 (0.16)	9 (0.35)	25 (0.98)	63 (2.48)	65 (2.56)	70 (2.76)	80 (3.15)	6.6 (0.26)
01□□AJ1□□	1/5	233 (9.17)	173 (6.81)	98.5 (3.88)	60 (2.36)	4 (0.16)	9 (0.35)	25 (0.98)	63 (2.48)	65 (2.56)	70 (2.76)	80 (3.15)	6.6 (0.26)
01□□AJ3□□	3/31	233 (9.17)	173 (6.81)	98.5 (3.88)	60 (2.36)	4 (0.16)	9 (0.35)	25 (0.98)	63 (2.48)	65 (2.56)	70 (2.76)	80 (3.15)	6.6 (0.26)
01□□AJC□□	1/21	268 (10.55)	194 (7.64)	120 (4.72)	74 (2.91)	4 (0.16)	10 (0.39)	32 (1.26)	83 (3.27)	85 (3.35)	90 (3.54)	105 (4.13)	9 (0.35)
01□□AJ7□□	1/33	268 (10.55)	194 (7.64)	120 (4.72)	74 (2.91)	4 (0.16)	10 (0.39)	32 (1.26)	83 (3.27)	85 (3.35)	90 (3.54)	105 (4.13)	9 (0.35)

Table 4.12 Servomotors with Standard Backlash Gears (L1 to T) Units mm (in)

Model SGMAH-	L1	L2	L3	Q	S	*Tap × depth	QK	U	W	T	Approx. Mass kg (lb)
A3□□AJ1□□	30 (1.18)	25 (0.98)	28 (1.10)	25 (0.98)	14 (0.55)	M4 × 8L	20 (0.79)	3 (0.12)	5 (0.20)	5 (0.20)	1.2 (2.65)
A3□□AJ3□□	30 (1.18)	25 (0.98)	28 (1.10)	25 (0.98)	14 (0.55)	M4 × 8L	20 (0.79)	3 (0.12)	5 (0.20)	5 (0.20)	1.2 (2.65)
A3□□AJC□□	30 (1.18)	25 (0.98)	28 (1.10)	25 (0.98)	14 (0.55)	M4 × 8L	20 (0.79)	3 (0.12)	5 (0.20)	5 (0.20)	1.3 (2.87)

Servodrive Dimensional Drawings

4 1 1 SGMAH Servomotors

Model SGMAH-	L1	L2	L3	Q	S	*Tap × depth	QK	U	W	T	Approx. Mass kg (lb)
A3□□AJ7□□	30 (1 18)	25 (0 98)	28 (1 10)	25 (0 98)	14 (0 55)	M4 × 8L	20 (0 79)	3 (0 12)	5 (0 20)	5 (0 20)	1 3 (2 87)
A5□□AJ1□□	30 (1 18)	25 (0 98)	28 (1 10)	25 (0 98)	14 (0 55)	M4 × 8L	20 (0 79)	3 (0 12)	5 (0 20)	5 (0 20)	1 3 (2 87)
A5□□AJ3□□	32 (1 26)	28 (1 10)	30 (1 18)	28 (1 10)	16 (0 63)	M4 × 8L	25 (0 98)	3 (0 12)	5 (0 20)	5 (0 20)	1 5 (3 31)
A5□□AJC□□	32 (1 26)	28 (1 10)	30 (1 18)	28 (1 10)	16 (0 63)	M4 × 8L	25 (0 98)	3 (0 12)	5 (0 20)	5 (0 20)	1 6 (3 53)
A5□□AJ7□□	32 (1 26)	28 (1 10)	30 (1 18)	28 (1 10)	16 (0 63)	M4 × 8L	25 (0 98)	3 (0 12)	5 (0 20)	5 (0 20)	1 6 (3 53)
01□□AJ1□□	32 (1 26)	28 (1 10)	30 (1 18)	28 (1 10)	16 (0 63)	M4 × 8L	25 (0 98)	3 (0 12)	5 (0 20)	5 (0 20)	1 6 (3 53)
01□□AJ3□□	32 (1 26)	28 (1 10)	30 (1 18)	28 (1 10)	16 (0 63)	M4 × 8L	25 (0 98)	3 (0 12)	5 (0 20)	5 (0 20)	1 6 (3 53)
01□□AJC□□	38 (1 50)	36 (1 42)	36 (1 42)	36 (1 42)	20 (0 79)	M5 × 10L	32 (1 26)	3 5 (0 14)	6 (0 24)	6 (0 24)	2 7 (5 95)
01□□AJ7□□	38 (1 50)	36 (1 42)	36 (1 42)	36 (1 42)	20 (0 79)	M5 × 10L	32 (1 26)	3 5 (0 14)	6 (0 24)	6 (0 24)	2 7 (5 95)

• Dimensional Tolerances

Model SGMAH-	Flange Face Dimensions mm (in)		Shaft-end Dimensions mm (in)	
	LB		S	
A3□□AJ1□□	56	$2 22 - \begin{smallmatrix} 0 \\ 0 0012 \end{smallmatrix}$	14	$0 56 - \begin{smallmatrix} 0 \\ 0 0007 \end{smallmatrix}$
A3□□AJ3□□	56	$2 22 - \begin{smallmatrix} 0 \\ 0 0012 \end{smallmatrix}$	14	$0 56 - \begin{smallmatrix} 0 \\ 0 0007 \end{smallmatrix}$
A3□□AJC□□	56	$2 22 - \begin{smallmatrix} 0 \\ 0 0012 \end{smallmatrix}$	14	$0 56 - \begin{smallmatrix} 0 \\ 0 0007 \end{smallmatrix}$
A3□□AJ7□□	56	$2 22 - \begin{smallmatrix} 0 \\ 0 0012 \end{smallmatrix}$	14	$0 56 - \begin{smallmatrix} 0 \\ 0 0007 \end{smallmatrix}$
A5□□AJ1□□	56	$2 22 - \begin{smallmatrix} 0 \\ 0 0012 \end{smallmatrix}$	14	$0 56 - \begin{smallmatrix} 0 \\ 0 0007 \end{smallmatrix}$
A5□□AJ3□□	65	$2 58 - \begin{smallmatrix} 0 \\ 0 0012 \end{smallmatrix}$	16	$0 64 - \begin{smallmatrix} 0 \\ 0 0007 \end{smallmatrix}$
A5□□AJC□□	65	$2 58 - \begin{smallmatrix} 0 \\ 0 0012 \end{smallmatrix}$	16	$0 64 - \begin{smallmatrix} 0 \\ 0 0007 \end{smallmatrix}$
A5□□AJ7□□	65	$2 58 - \begin{smallmatrix} 0 \\ 0 0012 \end{smallmatrix}$	16	$0 64 - \begin{smallmatrix} 0 \\ 0 0007 \end{smallmatrix}$
01□□AJ1□□	65	$2 58 - \begin{smallmatrix} 0 \\ 0 0012 \end{smallmatrix}$	16	$0 64 - \begin{smallmatrix} 0 \\ 0 0007 \end{smallmatrix}$
01□□AJ3□□	65	$2 58 - \begin{smallmatrix} 0 \\ 0 0012 \end{smallmatrix}$	16	$0 64 - \begin{smallmatrix} 0 \\ 0 0007 \end{smallmatrix}$
01□□AJC□□	85	$3 37 - \begin{smallmatrix} 0 \\ 0 0014 \end{smallmatrix}$	20	$0 79 - \begin{smallmatrix} 0 \\ 0 0008 \end{smallmatrix}$
01□□AJ7□□	85	$3 37 - \begin{smallmatrix} 0 \\ 0 0014 \end{smallmatrix}$	20	$0 79 - \begin{smallmatrix} 0 \\ 0 0008 \end{smallmatrix}$

SGMAH: 200 W, 400 W, 750 W With Brakes and Gears

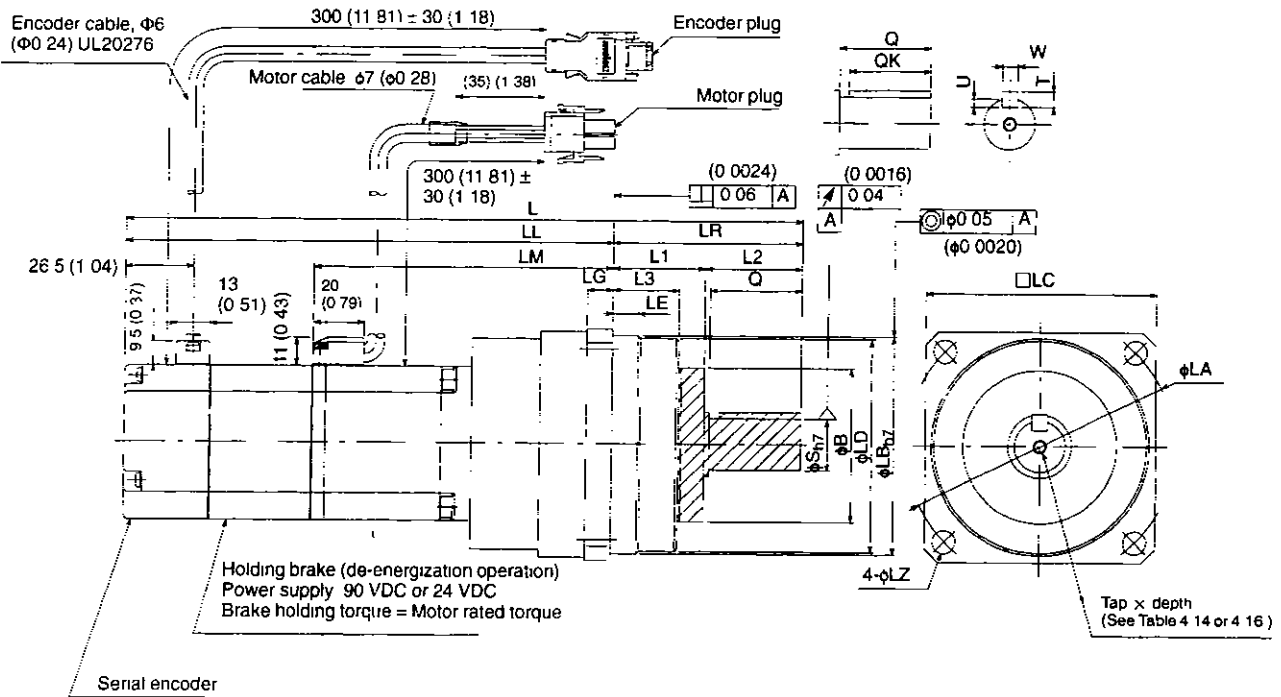

Table 4 13 Servomotors with Low-backlash Gears (L to LZ)

Units mm (in)

Model SGMAH-	Gear Ratio	L	LL	LM	LR	LE	LG	B	LD	LB	LC	LA	LZ
02□□AG1□□	1/5	249 (9.80)	175 (6.89)	100.5 (3.96)	74 (2.91)	10 (0.39)	10 (0.39)	60 (2.36)	83 (3.27)	85 (3.35)	90 (3.54)	105 (4.13)	9 (0.35)
02□□AGB□□	1/11	266 (10.47)	192 (7.56)	117.5 (4.63)	74 (2.91)	10 (0.39)	10 (0.39)	60 (2.36)	83 (3.27)	85 (3.35)	90 (3.54)	105 (4.13)	9 (0.35)
02□□AGC□□	1/21	284 (11.18)	200 (7.87)	125.5 (4.94)	84 (3.31)	12 (0.47)	12 (0.47)	70 (2.76)	96 (3.78)	100 (3.94)	105 (4.13)	120 (4.72)	9 (0.35)
02□□AG7□□	1/33	284 (11.18)	200 (7.87)	125.5 (4.94)	84 (3.31)	12 (0.47)	12 (0.47)	70 (2.76)	96 (3.78)	100 (3.94)	105 (4.13)	120 (4.72)	9 (0.35)
04A□AG1□□	1/5	277 (10.91)	203 (7.99)	128.5 (5.06)	74 (2.91)	10 (0.39)	10 (0.39)	60 (2.36)	83 (3.27)	85 (3.35)	90 (3.54)	105 (4.13)	9 (0.35)
04A□AGB□□	1/11	312 (12.28)	228 (8.98)	153.5 (6.04)	84 (3.31)	12 (0.47)	12 (0.47)	70 (2.76)	96 (3.78)	100 (3.94)	105 (4.13)	120 (4.72)	9 (0.35)
04A□AGC□□	1/21	341 (13.43)	236 (9.29)	161.5 (6.36)	105 (4.13)	14 (0.55)	13 (0.51)	90 (3.54)	112 (4.41)	115 (4.53)	120 (4.72)	135 (5.31)	11 (0.43)
04A□AG7□□	1/33	341 (13.43)	236 (9.29)	161.5 (6.36)	105 (4.13)	14 (0.55)	13 (0.51)	90 (3.54)	112 (4.41)	115 (4.53)	120 (4.72)	135 (5.31)	11 (0.43)
08A□AG1□□	1/5	316.5 (12.46)	232.5 (9.15)	153 (6.02)	84 (3.31)	12 (0.47)	12 (0.47)	70 (2.76)	96 (3.78)	100 (3.94)	105 (4.13)	120 (4.72)	9 (0.35)
08A□AGB□□	1/11	366.5 (14.43)	261.5 (10.30)	182 (7.17)	105 (4.13)	14 (0.55)	13 (0.51)	90 (3.54)	112 (4.41)	115 (4.53)	120 (4.72)	135 (5.31)	11 (0.43)
08A□AGC□□	1/21	410.5 (16.16)	268.5 (10.57)	189 (7.44)	142 (5.59)	16 (0.63)	15 (0.59)	107 (4.21)	134 (5.28)	140 (5.51)	145 (5.71)	165 (6.50)	14 (0.55)
08A□AG7□□	1/33	410.5 (16.16)	268.5 (10.57)	189 (7.44)	142 (5.59)	16 (0.63)	15 (0.59)	107 (4.21)	134 (5.28)	140 (5.51)	145 (5.71)	165 (6.50)	14 (0.55)



Table 4 14 Servomotors with Low-backlash Gears (L1 to T)

Units mm (in)

Model SGMAH-	L1	L2	L3	Q	S	*Tap × depth	QK	U	W	T	Approx. Mass kg (lb)
02□□AG1□□	36 (1.42)	38 (1.50)	26 (1.02)	36 (1.42)	20 (0.79)	M5 × 10L	32 (1.26)	3.5 (0.14)	6 (0.24)	6 (0.24)	3.7 (8.16)
02□□AGB□□	36 (1.42)	38 (1.50)	26 (1.02)	36 (1.42)	20 (0.79)	M5 × 10L	32 (1.26)	3.5 (0.14)	6 (0.24)	6 (0.24)	3.8 (8.38)
02□□AGC□□	40 (1.57)	44 (1.73)	29 (1.14)	42 (1.65)	25 (0.98)	M6 × 12L	36 (1.42)	4 (0.16)	8 (0.31)	7 (0.28)	5.0 (11.0)
02□□AG7□□	40 (1.57)	44 (1.73)	29 (1.14)	42 (1.65)	25 (0.98)	M6 × 12L	36 (1.42)	4 (0.16)	8 (0.31)	7 (0.28)	5.0 (11.0)
04A□AG1□□	36 (1.42)	38 (1.50)	26 (1.02)	36 (1.42)	20 (0.79)	M5 × 10L	32 (1.26)	3.5 (0.14)	6 (0.24)	6 (0.24)	4.3 (9.48)
04A□AGB□□	40 (1.57)	44 (1.73)	29 (1.14)	42 (1.65)	25 (0.98)	M6 × 12L	36 (1.42)	4 (0.16)	8 (0.31)	7 (0.28)	5.6 (12.3)
04A□AGC□□	45 (1.77)	60 (2.36)	33 (1.30)	58 (2.28)	32 (1.26)	M8 × 16L	50 (1.97)	5 (0.20)	10 (0.39)	8 (0.31)	7.5 (16.5)
04A□AG7□□	45 (1.77)	60 (2.36)	33 (1.30)	58 (2.28)	32 (1.26)	M8 × 16L	50 (1.97)	5 (0.20)	10 (0.39)	8 (0.31)	7.5 (16.5)
08A□AG1□□	40 (1.57)	44 (1.73)	29 (1.14)	42 (1.65)	25 (0.98)	M6 × 12L	36 (1.42)	4 (0.16)	8 (0.31)	7 (0.28)	7.5 (16.5)
08A□AGB□□	45 (1.77)	60 (2.36)	33 (1.30)	58 (2.28)	32 (1.26)	M8 × 16L	50 (1.97)	5 (0.20)	10 (0.39)	8 (0.31)	9.7 (21.4)
08A□AGC□□	57 (2.24)	85 (3.35)	42 (1.65)	82 (3.23)	40 (1.57)	M10 × 20L	70 (2.76)	5 (0.20)	12 (0.47)	8 (0.31)	14.1 (31.1)
08A□AG7□□	57 (2.24)	85 (3.35)	42 (1.65)	82 (3.23)	40 (1.57)	M10 × 20L	70 (2.76)	5 (0.20)	12 (0.47)	8 (0.31)	14.1 (31.1)

• Dimensional Tolerances

Model SGMAH-	Flange Face Dimensions mm (in)	Shaft-end Dimensions mm (in)
	LB	S
02□□AG1□□	85 ⁰ / _{-0.035} (3.37 - ⁰ / _{0.0014})	20 ⁰ / _{-0.021} (0.79 - ⁰ / _{0.0008})
02□□AGB□□	85 ⁰ / _{-0.035} (3.37 - ⁰ / _{0.0014})	20 ⁰ / _{-0.021} (0.79 - ⁰ / _{0.0008})
02□□AGC□□	100 ⁰ / _{-0.035} (3.97 - ⁰ / _{0.0014})	25 ⁰ / _{-0.021} (0.99 - ⁰ / _{0.0008})
02□□AG7□□	100 ⁰ / _{-0.035} (3.97 - ⁰ / _{0.0014})	25 ⁰ / _{-0.021} (0.99 - ⁰ / _{0.0008})
04A□AG1□□	85 ⁰ / _{-0.035} (3.37 - ⁰ / _{0.0014})	20 ⁰ / _{-0.021} (0.79 - ⁰ / _{0.0008})
04A□AGB□□	100 ⁰ / _{-0.035} (3.97 - ⁰ / _{0.0014})	25 ⁰ / _{-0.021} (0.99 - ⁰ / _{0.0008})
04A□AGC□□	115 ⁰ / _{-0.035} (4.57 - ⁰ / _{0.0014})	32 ⁰ / _{-0.025} (1.27 - ⁰ / _{0.0010})
04A□AG7□□	115 ⁰ / _{-0.035} (4.57 - ⁰ / _{0.0014})	32 ⁰ / _{-0.025} (1.27 - ⁰ / _{0.0010})
08A□AG1□□	100 ⁰ / _{-0.035} (3.97 - ⁰ / _{0.0014})	25 ⁰ / _{-0.021} (0.99 - ⁰ / _{0.0008})
08A□AGB□□	115 ⁰ / _{-0.035} (4.57 - ⁰ / _{0.0014})	32 ⁰ / _{-0.025} (1.27 - ⁰ / _{0.0010})

Model SGMAH-	Flange Face Dimensions mm (in)		Shaft-end Dimensions mm (in)	
	LB		S	
08A□AGC□□	140 ⁰ _{-0.040}	(5.56 ⁰ _{-0.0016})	40 ⁰ _{-0.025}	(1.59 ⁰ _{-0.0010})
08A□AG7□□	140 ⁰ _{-0.040}	(5.56 ⁰ _{-0.0016})	40 ⁰ _{-0.025}	(1.59 ⁰ _{-0.0010})

Table 4 15 Servomotors with Standard Backlash Gears (L to LZ) Units mm (in)

Model SGMAH-	Gear Ratio	L	LL	LM	LR	LE	LG	B	LD	LB	LC	LA	LZ
02□□AJ1□□	1/5	252.5 (9.94)	178.5 (7.03)	104 (4.09)	74 (2.91)	4 (0.16)	10 (0.39)	32 (1.26)	83 (3.27)	85 (3.35)	90 (3.54)	105 (4.13)	9 (0.35)
02□□AJ3□□	3/31	252.5 (9.94)	178.5 (7.03)	104 (4.09)	74 (2.91)	4 (0.16)	10 (0.39)	32 (1.26)	83 (3.27)	85 (3.35)	90 (3.54)	105 (4.13)	9 (0.35)
02□□AJC□□	1/21	290 (11.42)	206 (8.11)	131.5 (5.18)	84 (3.31)	4 (0.16)	12 (0.47)	40 (1.57)	98 (3.86)	100 (3.94)	105 (4.13)	120 (4.72)	9 (0.35)
02□□AJ7□□	1/33	290 (11.42)	206 (8.11)	131.5 (5.18)	84 (3.31)	4 (0.16)	12 (0.47)	40 (1.57)	98 (3.86)	100 (3.94)	105 (4.13)	120 (4.72)	9 (0.35)
04A□AJ1□□	1/5	280.5 (11.04)	206.5 (8.13)	132 (5.20)	74 (2.91)	4 (0.16)	10 (0.39)	32 (1.26)	83 (3.27)	85 (3.35)	90 (3.54)	105 (4.13)	9 (0.35)
04A□AJ3□□	3/31	297 (11.69)	213 (8.39)	138.5 (5.45)	84 (3.31)	4 (0.16)	12 (0.47)	40 (1.57)	98 (3.86)	100 (3.94)	105 (4.13)	120 (4.72)	9 (0.35)
04A□AJC□□	1/21	346 (13.62)	241 (9.49)	166.5 (6.56)	105 (4.13)	5 (0.20)	13 (0.51)	50 (1.97)	112 (4.41)	115 (4.53)	120 (4.72)	135 (5.31)	11 (0.43)
04A□AJ7□□	1/33	346 (13.62)	241 (9.49)	166.5 (6.56)	105 (4.13)	5 (0.20)	13 (0.51)	50 (1.97)	112 (4.41)	115 (4.53)	120 (4.72)	135 (5.31)	11 (0.43)
08A□AJ1□□	1/5	322.5 (12.70)	238.5 (9.39)	159 (6.26)	84 (3.31)	4 (0.16)	12 (0.47)	40 (1.57)	98 (3.86)	100 (3.94)	105 (4.13)	120 (4.72)	9 (0.35)
08A□AJ3□□	3/31	346.5 (13.64)	241.5 (9.51)	162 (6.38)	105 (4.13)	5 (0.20)	13 (0.51)	50 (1.97)	112 (4.41)	115 (4.53)	120 (4.72)	135 (5.31)	11 (0.43)
08A□AJC□□	1/21	375.5 (14.78)	268.5 (10.57)	189 (7.44)	107 (4.21)	10 (0.39)	15 (0.59)	107 (4.21)	134 (5.28)	140 (5.51)	145 (5.71)	165 (6.50)	14 (0.55)
08A□AJ7□□	1/33	375.5 (14.78)	268.5 (10.57)	189 (7.44)	107 (4.21)	10 (0.39)	15 (0.59)	107 (4.21)	134 (5.28)	140 (5.51)	145 (5.71)	165 (6.50)	14 (0.55)

Table 4.16 Servomotors with Standard Backlash Gears (L1 to T) Units mm (in)

Model SGMAH-	L1	L2	L3	Q	S	*Tap × depth	QK	U	W	T	Approx. Mass kg (lb)
02□□AJ1□□	38 (1.50)	36 (1.42)	36 (1.42)	36 (1.42)	20 (0.79)	M5 × 10L	32 (1.26)	3.5 (0.14)	6 (0.24)	6 (0.24)	3.3 (7.28)
02□□AJ3□□	38 (1.50)	36 (1.42)	36 (1.42)	36 (1.42)	20 (0.79)	M5 × 10L	32 (1.26)	3.5 (0.14)	6 (0.24)	6 (0.24)	3.3 (7.28)
02□□AJC□□	42 (1.65)	42 (1.65)	40 (1.57)	42 (1.65)	25 (0.98)	M6 × 12L	36 (1.42)	4 (0.16)	8 (0.31)	7 (0.28)	4.7 (10.4)
02□□AJ7□□	42 (1.65)	42 (1.65)	40 (1.57)	42 (1.65)	25 (0.98)	M6 × 12L	36 (1.42)	4 (0.16)	8 (0.31)	7 (0.28)	4.7 (10.4)
04A□AJ1□□	38 (1.50)	36 (1.42)	36 (1.42)	36 (1.42)	20 (0.79)	M5 × 10L	32 (1.26)	3.5 (0.14)	6 (0.24)	6 (0.24)	3.9 (8.60)
04A□AJ3□□	42 (1.65)	42 (1.65)	40 (1.57)	42 (1.65)	25 (0.98)	M6 × 12L	36 (1.42)	4 (0.16)	8 (0.31)	7 (0.28)	4.8 (10.6)

Model SGMAH-	L1	L2	L3	Q	S	*Tap × depth	QK	U	W	T	Approx Mass kg (lb)
04A□AJC□□	47 (1 85)	58 (2 28)	45 (1 77)	58 (2 28)	32 (1 26)	M8 × 16L	50 (1 97)	5 (0 20)	10 (0 39)	8 (0 31)	6 9 (15 2)
04A□AJ7□□	47 (1 85)	58 (2 28)	45 (1 77)	58 (2 28)	32 (1 26)	M8 × 16L	50 (1 97)	5 (0 20)	10 (0 39)	8 (0 31)	6 9 (15 2)
08A□AJ1□□	42 (1 65)	42 (1 65)	40 (1 57)	42 (1 65)	25 (0 98)	M6 × 12L	36 (1 42)	4 (0 16)	8 (0 31)	7 (0 28)	6 9 (15 2)
08A□AJ3□□	47 (1 85)	58 (2 28)	45 (1 77)	58 (2 28)	32 (1 26)	M8 × 16L	50 (1 97)	5 (0 20)	10 (0 39)	8 (0 31)	8 4 (18 5)
08A□AJC□□	44 (1 73)	63 (2 48)	42 (1 65)	60 (2 36)	40 (1 57)	M10 × 20L	45 (1 77)	5 (0 20)	12 (0 47)	8 (0 31)	13 3 (29 3)
08A□AJ7□□	44 (1 73)	63 (2 48)	42 (1 65)	60 (2 36)	40 (1 57)	M10 × 20L	45 (1 77)	5 (0 20)	12 (0 47)	8 (0 31)	13 3 (29 3)

• Dimensional Tolerances

Model SGMAH-	Flange Face Dimensions mm (in)		Shaft-end Dimensions mm (in)	
	LB		S	
02□□AJ1□□	85	$0_{-0.035} \left(3.37 - 0.0014 \right)$	20	$0_{-0.021} \left(0.79 - 0.0008 \right)$
02□□AJ3□□	85	$0_{-0.035} \left(3.37 - 0.0014 \right)$	20	$0_{-0.021} \left(0.79 - 0.0008 \right)$
02□□AJC□□	100	$0_{-0.035} \left(3.97 - 0.0014 \right)$	25	$0_{-0.021} \left(0.99 - 0.0008 \right)$
02□□AJ7□□	100	$0_{-0.035} \left(3.97 - 0.0014 \right)$	25	$0_{-0.021} \left(0.99 - 0.0008 \right)$
04A□AJ1□□	85	$0_{-0.035} \left(3.37 - 0.0014 \right)$	20	$0_{-0.021} \left(0.79 - 0.0008 \right)$
04A□AJ3□□	100	$0_{-0.035} \left(3.97 - 0.0014 \right)$	25	$0_{-0.021} \left(0.99 - 0.0008 \right)$
04A□AJC□□	115	$0_{-0.035} \left(4.57 - 0.0014 \right)$	32	$0_{-0.025} \left(1.27 - 0.0010 \right)$
04A□AJ7□□	115	$0_{-0.035} \left(4.57 - 0.0014 \right)$	32	$0_{-0.025} \left(1.27 - 0.0010 \right)$
08A□AJ1□□	100	$0_{-0.035} \left(3.97 - 0.0014 \right)$	25	$0_{-0.021} \left(0.99 - 0.0008 \right)$
08A□AJ3□□	115	$0_{-0.035} \left(4.57 - 0.0014 \right)$	32	$0_{-0.025} \left(1.27 - 0.0010 \right)$
08A□AJC□□	140	$0_{-0.040} \left(5.56 - 0.0016 \right)$	40	$0_{-0.025} \left(1.59 - 0.0010 \right)$
08A□AJ7□□	140	$0_{-0.040} \left(5.56 - 0.0016 \right)$	40	$0_{-0.025} \left(1.59 - 0.0010 \right)$

Servomotor and Encoder Lead Specifications

The Servomotor and Encoder lead specifications are the same as those for standard Servomotors

4.1.2 SGMPH Servomotors

■ Standard Servomotors Without Gears

SGMPH: 100 W, 200 W, 400 W, 750 W, 1500 W Without Brakes

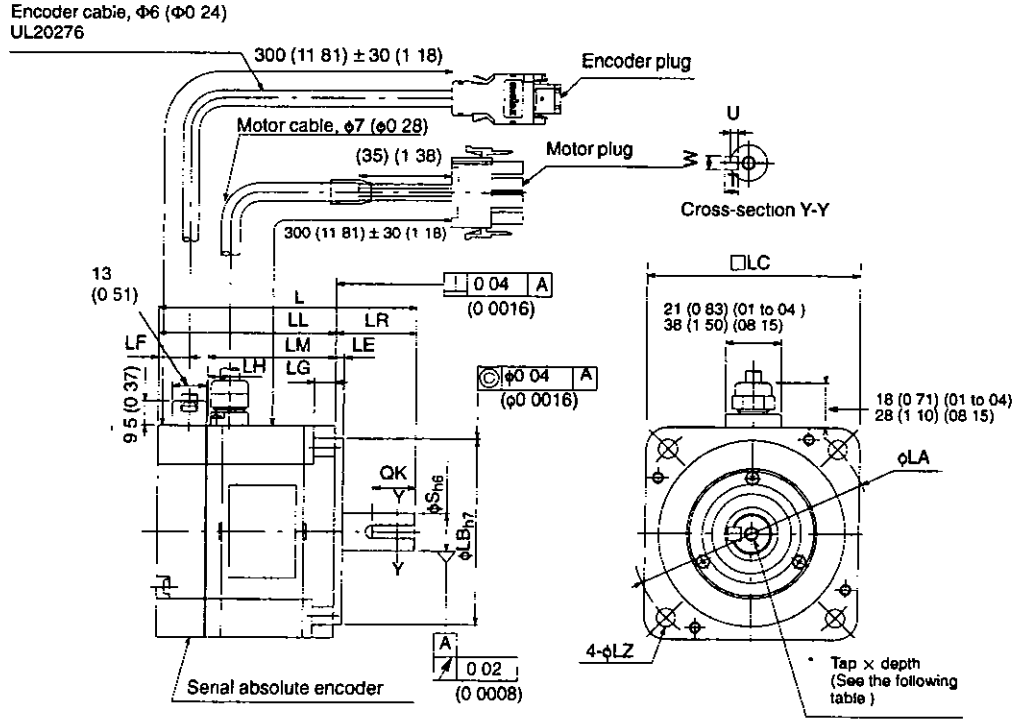

Units mm (in)

Model SGMPH-	L	LL	LM	LR	LE	LG	LF	LC	LA	LZ	S	LB	LH	*Tap \times depth	QK	U	W	T	Approx Mass kg (lb)
01□□A21	87	62	42.5	25	3	6	12.5	60	70	5.5	8	50	10.55	No tap	No key				0.7 (1.54)
01□□A41	(3.43)	(2.44)	(1.67)	(0.98)	(0.12)	(0.24)	(0.49)	(2.36)	(2.76)	(0.22)	(0.31)	(1.97)	(0.42)		14	1.8	3	3	
01□□A61													(0.55)		(0.071)	(0.12)	(0.12)		
02□□A21	97	67	48.1	30	3	8	11.9	80	90	7	14	70	8.25	No tap	No key				1.4 (3.09)
02□□A41	(3.82)	(2.64)	(1.89)	(1.18)	(0.12)	(0.31)	(0.47)	(3.15)	(3.54)	(0.28)	(0.55)	(2.76)	(0.32)		16	3	5	5	
02□□A61													(0.63)		(0.12)	(0.20)	(0.20)		
04A□A21	117	87	68.1	30	3	8	11.9	80	90	7	14	70	8.25	No tap	No key				2.1 (4.63)
04A□A41	(4.61)	(3.43)	(2.68)	(1.18)	(0.12)	(0.31)	(0.47)	(3.15)	(3.54)	(0.28)	(0.55)	(2.76)	(0.32)		16	3	5	5	
04A□A61													(0.63)		(0.12)	(0.20)	(0.20)		
08A□A21	126.5	86.5	66.7	40	3.5	10	12.8	120	145	10	16	110	10.5	No tap	No key				4.2 (9.26)
08A□A41	(4.98)	(3.41)	(2.63)	(1.57)	(0.14)	(0.39)	(0.50)	(4.72)	(5.71)	(0.39)	(0.63)	(4.33)	(0.41)		22	3	5	5	
08A□A61													(0.87)		(0.12)	(0.20)	(0.20)		
15A□A21	154.5	114.5	94.7	40	3.5	10	12.8	120	145	10	19	110	10.5	No tap	No key				6.6 (14.6)
15A□A41	(6.08)	(4.51)	(3.73)	(1.57)	(0.14)	(0.39)	(0.50)	(4.72)	(5.71)	(0.39)	(0.75)	(4.33)	(0.41)		22	3.5	6	6	
15A□A61													(0.87)		(0.14)	(0.24)	(0.24)		

• Dimensional Tolerances

Model SGMPH-	Shaft-end Dimensions mm (in)	Flange Face Dimensions mm (in)
	S	LB
01□□A21	$8 -_{0.009}^0$ ($0.32 -_{0.0004}^0$)	$50 -_{0.025}^0$ ($1.98 -_{0.0010}^0$)
01□□A41		
01□□A61		
02□□A21	$14 -_{0.011}^0$ ($0.56 -_{0.0004}^0$)	$70 -_{0.030}^0$ ($2.78 -_{0.0012}^0$)
02□□A41		
02□□A61		
04A□A21	$14 -_{0.011}^0$ ($0.56 -_{0.0004}^0$)	$70 -_{0.030}^0$ ($2.78 -_{0.0012}^0$)
04A□A41		
04A□A61		
08A□A21	$16 -_{0.011}^0$ ($0.64 -_{0.0004}^0$)	$110 -_{0.035}^0$ ($4.37 -_{0.0014}^0$)
08A□A41		
08A□A61		
15A□A21	$19 -_{0.013}^0$ ($0.75 -_{0.0005}^0$)	$110 -_{0.035}^0$ ($4.37 -_{0.0014}^0$)
15A□A41		
15A□A61		

SGMPH: 100 W, 200 W, 400 W, 750 W, 1500 W With Brakes

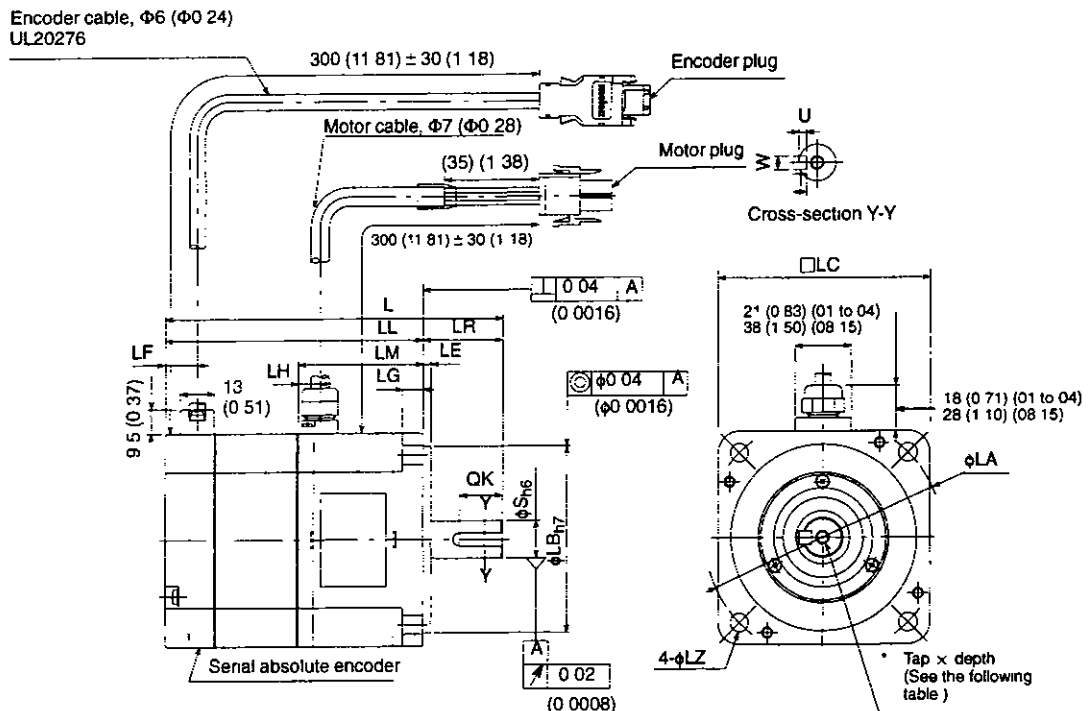

Units mm (in)

Model SGMPH-	L	LL	LM	LR	LE	LG	LF	LC	LA	LZ	S	LB	LH	*Tap × depth	OK	U	W	T	Approx Mass Kg (lb)
01□□A2□ 01□□A4□ 01□□A6□	116 (4.57)	91 (3.58)	42.5 (1.67)	25 (0.98)	3 (0.12)	6 (0.24)	12.5 (0.49)	60 (2.36)	70 (2.76)	5.5 (0.22)	8 (0.31)	50 (1.97)	10.55 (0.42)	No tap	No key				0.9 (1.98)
														M3 × 6L	14 (0.55)	18 (0.071)	3 (0.12)	3 (0.12)	
02□□A2□ 02□□A4□ 02□□A6□	128.5 (5.06)	98.5 (3.88)	48.1 (1.89)	30 (1.18)	3 (0.12)	8 (0.31)	11.9 (0.47)	80 (3.15)	90 (3.54)	7 (0.28)	14 (0.55)	70 (2.76)	8.25 (0.32)	No tap	No key				1.9 (4.19)
														M5 × 8L	16 (0.63)	3 (0.12)	5 (0.20)	5 (0.20)	
04A□A2□ 04A□A4□ 04A□A6□	148.5 (5.85)	118.5 (4.67)	68.1 (2.68)	30 (1.18)	3 (0.12)	8 (0.31)	11.9 (0.47)	80 (3.15)	90 (3.54)	7 (0.28)	14 (0.55)	70 (2.76)	8.25 (0.32)	No tap	No key				2.6 (5.73)
														M5 × 8L	16 (0.63)	3 (0.12)	5 (0.20)	5 (0.20)	
08A□A2□ 08A□A4□ 08A□A6□	163 (6.42)	123 (4.84)	66.7 (2.63)	40 (1.57)	3.5 (0.14)	10 (0.39)	12.8 (0.50)	120 (4.72)	145 (5.71)	10 (0.39)	16 (0.63)	110 (4.33)	10.5 (0.41)	No tap	No key				5.7 (12.6)
														M5 × 8L	22 (0.87)	3 (0.12)	5 (0.20)	5 (0.20)	
15A□A2□ 15A□A4□ 15A□A6□	188 (7.40)	148 (5.83)	94.7 (3.73)	40 (1.57)	3.5 (0.14)	10 (0.39)	12.8 (0.50)	120 (4.72)	145 (5.71)	10 (0.39)	19 (0.75)	110 (4.33)	10.5 (0.41)	No tap	No key				8.1 (17.8)
														M6 × 10L	22 (0.87)	3.5 (0.14)	6 (0.24)	6 (0.24)	

• Dimensional Tolerances

Model SGMPH-	Shaft-end Dimensions mm (in)	Flange Face Dimensions mm (in)
	S	LB
01□□A2□ 01□□A4□ 01□□A6□	$8 \begin{matrix} 0 \\ -0.009 \end{matrix} \left(0.32 \begin{matrix} 0 \\ -0.0004 \end{matrix} \right)$	$50 \begin{matrix} 0 \\ -0.025 \end{matrix} \left(1.98 \begin{matrix} 0 \\ -0.0010 \end{matrix} \right)$
02□□A2□ 02□□A4□ 02□□A6□	$14 \begin{matrix} 0 \\ -0.011 \end{matrix} \left(0.56 \begin{matrix} 0 \\ -0.0004 \end{matrix} \right)$	$70 \begin{matrix} 0 \\ -0.030 \end{matrix} \left(2.78 \begin{matrix} 0 \\ -0.0012 \end{matrix} \right)$
04A□A2□ 04A□A4□ 04A□A6□	$14 \begin{matrix} 0 \\ -0.011 \end{matrix} \left(0.56 \begin{matrix} 0 \\ -0.0004 \end{matrix} \right)$	$70 \begin{matrix} 0 \\ -0.030 \end{matrix} \left(2.78 \begin{matrix} 0 \\ -0.0012 \end{matrix} \right)$
08A□A2□ 08A□A4□ 08A□A6□	$16 \begin{matrix} 0 \\ -0.011 \end{matrix} \left(0.64 \begin{matrix} 0 \\ -0.0004 \end{matrix} \right)$	$110 \begin{matrix} 0 \\ -0.035 \end{matrix} \left(4.37 \begin{matrix} 0 \\ -0.0014 \end{matrix} \right)$
15A□A2□ 15A□A4□ 15A□A6□	$19 \begin{matrix} 0 \\ -0.013 \end{matrix} \left(0.75 \begin{matrix} 0 \\ -0.0005 \end{matrix} \right)$	$110 \begin{matrix} 0 \\ -0.035 \end{matrix} \left(4.37 \begin{matrix} 0 \\ -0.0014 \end{matrix} \right)$

SGMPH Servomotor and Encoder Lead Specifications

● Motor Plug (SGMPH-01 to 08)

Standard Part



Plug 350779-1 (AMP)
 Pin 350561-3 or 350690-3 (Nos 1 to 3)
 Ground pin 770210-1 (No 4)

Connected to
 Cap 350780-1
 Socket 350570-3 or 350689-3

1	Phase U	Red
2	Phase V	White
3	Phase W	Blue
4	FG	Green/Yellow

With Brake



Plug 350715-1 (AMP)
 Pin 350561-3 or 350690-3 (Except No 4)
 Ground pin 770210-1 (No 4)

Connected to
 Cap 350781-1
 Socket 350570-3 or 350689-3

1	Phase U	Red
2	Phase V	White
3	Phase W	Blue
4	FG	Green/Yellow
5	Brake terminal	Black
6	Brake terminal	Black

● Motor Plug (SGMPH-15)

Standard Part



Plug 350779-1 (AMP)
 Pin 350218-6 or 350547-6 (Nos 1 to 3)
 Ground pin 350654-1 or 350669-1 (No 4)

Connected to
 Cap 350780-1
 Socket 350536-6 or 350550-6 (Nos 1 to 3)
 350570-3 or 350689-3 (No 4)

1	Phase U	Red
2	Phase V	White
3	Phase W	Blue
4	FG	Green/Yellow

With Brake



Plug 350715-1 (AMP)
 Pin 350218-6 or 350547-6 (Nos 1 to 3)
 350561-3 or 350690-3 (Nos 5, 6)
 Ground pin 350654-1 or 350669-1 (No 4)

Connected to
 Cap 350781-1
 Socket 350536-6 or 350550-6 (Nos 1 to 3)
 350570-3 or 350689-3 (Nos 4 to 6)

1	Phase U	Red
2	Phase V	White
3	Phase W	Blue
4	FG	Green/Yellow
5	Brake terminal	Black
6	Brake terminal	Black

● Servomotor Leads

Model SGMPH-	Lead Specifications
01	AWG22, UL2464
02 to 04	AWG20, UL2464
08	AWG20, UL2464
15	AWG16, UL2464

● Encoder Plug



Plug 55102-0600 (Molex Japan Co., Ltd)

Connected to
 Socket 54280-0600

**Lead Specifications for 16-bit
Serial Absolute Encoders**

1	PG 5 V	Red
2	PG 0 V	Black
3	BAT	Orange
4	0BAT	White/Orange
5	PS	Light blue
6	/PS	White/Light blue

**Lead Specifications for 13-bit
Serial Incremental Encoders**

1	PG 5 V	Red
2	PG 0 V	Black
3	-	-
4	-	-
5	PS	Light blue
6	/PS	White/Light blue



■ Servomotor Without Brakes and With Gears

Either standard backlash or low-backlash gears are available

SGMPH: 100 W, 200 W, 400 W, 750 W, 1500 W
Without Brakes and With Gears

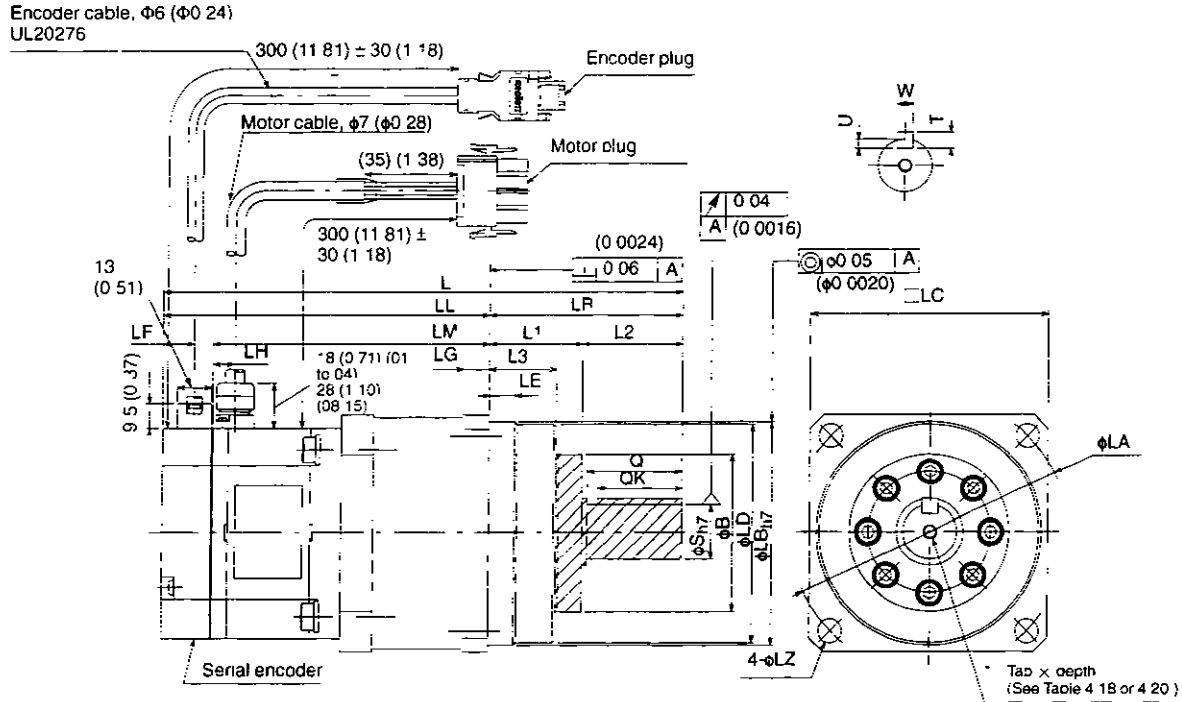

Table 4 17 Servomotors with Low-backlash Gears (L to LZ)

Units mm (in)

Model SGMPH-	Gear Ratio	L	LL	LM	LR	LE	LG	B	LD	LB	LC	LA	LZ
01□□AG1□1	1/5	169 (6.65)	109 (4.29)	89.5 (3.52)	60 (2.36)	8 (0.31)	9 (0.35)	50 (1.97)	64.5 (2.54)	65 (2.56)	70 (2.76)	80 (3.15)	6.6 (0.26)
01□□AGB□1	1/11	169 (6.65)	109 (4.29)	89.5 (3.52)	60 (2.36)	8 (0.31)	9 (0.35)	50 (1.97)	64.5 (2.54)	65 (2.56)	70 (2.76)	80 (3.15)	6.6 (0.26)
01□□AGC□1	1/21	192 (7.56)	118 (4.65)	98.5 (3.88)	74 (2.91)	10 (0.39)	10 (0.39)	60 (2.36)	83 (3.27)	85 (3.35)	90 (3.54)	105 (4.13)	9 (0.35)
01□□AG7□1	1/33	192 (7.56)	118 (4.65)	98.5 (3.88)	74 (2.91)	10 (0.39)	10 (0.39)	60 (2.36)	83 (3.27)	85 (3.35)	90 (3.54)	105 (4.13)	9 (0.35)
02□□AG1□1	1/5	197 (7.76)	123 (4.84)	104.1 (4.10)	74 (2.91)	10 (0.39)	10 (0.39)	60 (2.36)	83 (3.27)	85 (3.35)	90 (3.54)	105 (4.13)	9 (0.35)
02□□AGB□1	1/11	197 (7.76)	123 (4.84)	104.1 (4.10)	74 (2.91)	10 (0.39)	10 (0.39)	60 (2.36)	83 (3.27)	85 (3.35)	90 (3.54)	105 (4.13)	9 (0.35)
02□□AGC□1	1/21	215 (8.46)	131 (5.16)	112.1 (4.41)	84 (3.31)	12 (0.47)	12 (0.47)	70 (2.76)	96 (3.78)	100 (3.94)	105 (4.13)	120 (4.72)	9 (0.35)
02□□AG7□1	1/33	215 (8.46)	131 (5.16)	112.1 (4.41)	84 (3.31)	12 (0.47)	12 (0.47)	70 (2.76)	96 (3.78)	100 (3.94)	105 (4.13)	120 (4.72)	9 (0.35)
04A□AG1□1	1/5	217 (8.54)	143 (5.63)	124.1 (4.89)	74 (2.91)	10 (0.39)	10 (0.39)	60 (2.36)	83 (3.27)	85 (3.35)	90 (3.54)	105 (4.13)	9 (0.35)
04A□AGB□1	1/11	235 (9.25)	151 (5.94)	132.1 (5.20)	84 (3.31)	12 (0.47)	12 (0.47)	70 (2.76)	96 (3.78)	100 (3.94)	105 (4.13)	120 (4.72)	9 (0.35)

Model SGMPH-	Gear Ratio	L	LL	LM	LR	LE	LG	B	LD	LB	LC	LA	LZ
04A□AGC□1	1/21	264 (10 39)	159 (6 26)	140 1 (5 52)	105 (4 13)	14 (0 55)	13 (0 51)	90 (3 54)	112 (4 41)	115 (4 53)	120 (4 72)	135 (5 31)	11 (0 43)
04A□AG7□1	1/33	264 (10 39)	159 (6 26)	140 1 (5 52)	105 (4 13)	14 (0 55)	13 (0 51)	90 (3 54)	112 (4 41)	115 (4 53)	120 (4 72)	135 (5 31)	11 (0 43)
08A□AG1□1	1/5	234 5 (9 23)	150 5 (5 93)	130 7 (5 15)	84 (3 31)	12 (0 47)	12 (0 47)	70 (2 76)	96 (3 78)	100 (3 94)	105 (4 13)	120 (4 72)	9 (0 35)
08A□AGB□1	1/11	263 5 (10 37)	158 5 (6 24)	138 7 (5 46)	105 (4 13)	14 (0 55)	13 (0 51)	90 (3 54)	112 (4 41)	115 (4 53)	120 (4 72)	135 (5 31)	11 (0 43)
08A□AGC□1	1/21	316 5 (12 46)	174 5 (6 87)	154 7 (6 09)	142 (5 59)	10 (0 39)	15 (0 59)	100 (3 94)	134 (5 28)	140 (5 51)	145 (5 71)	165 (6 50)	14 (0 55)
08A□AG7□1	1/33	316 5 (12 46)	174 5 (6 87)	154 7 (6 09)	142 (5 59)	10 (0 39)	15 (0 59)	100 (3 94)	134 (5 28)	140 (5 51)	145 (5 71)	165 (6 50)	14 (0 55)
15A□AG1□1	1/5	291 5 (11 48)	186 5 (7 34)	166 7 (6 56)	105 (4 13)	14 (0 55)	13 (0 51)	90 (3 54)	112 (4 41)	115 (4 53)	120 (4 72)	135 (5 31)	11 (0 43)
15A□AGB□1	1/11	344 5 (13 56)	202 5 (7 97)	182 7 (7 19)	142 (5 59)	10 (0 39)	15 (0 59)	100 (3 94)	134 (5 28)	140 (5 51)	145 (5 71)	165 (6 50)	14 (0 55)
15A□AGC□1	1/21	364 5 (14 35)	208 5 (8 21)	188 7 (7 43)	156 (6 14)	16 (0 63)	16 (0 63)	135 (5 31)	163 (6 42)	165 (6 50)	170 (6 69)	190 (7 48)	14 (0 55)
15A□AG7□1	1/33	364 5 (14 35)	208 5 (8 21)	188 7 (7 43)	156 (6 14)	16 (0 63)	16 (0 63)	135 (5 31)	163 (6 42)	165 (6 50)	170 (6 69)	190 (7 48)	14 (0 55)

Table 4 18 Servomotors with Low-backlash Gears (L1 to T)

Units mm (in)

Model SGMPH-	L1 mm (in)	L2 mm (in)	L3 mm (in)	Q mm (in)	S mm (in)	LF mm (in)	LH mm (in)	*Tap × depth	OK mm (in)	U mm (in)	W mm (in)	T mm (in)	Approx. Mass kg (lb)
01□□AG1□1	30 (1 18)	30 (1 18)	22 (0 87)	28 (1 10)	16 (0 63)	12 5 (0 49)	10 55 (0 42)	M4 × 8L	25 (0 98)	3 (0 12)	5 (0 20)	5 (0 20)	1 7 (3 75)
01□□AGB□1	30 (1 18)	30 (1 18)	22 (0 87)	28 (1 10)	16 (0 63)	12 5 (0 49)	10 55 (0 42)	M4 × 8L	25 (0 98)	3 (0 12)	5 (0 20)	5 (0 20)	1 8 (3 97)
01□□AGC□1	36 (1 42)	38 (1 50)	26 (1 02)	36 (1 42)	20 (0 79)	12 5 (0 49)	10 55 (0 42)	M5 × 10L	32 (1 26)	3 5 (0 14)	6 (0 24)	6 (0 24)	2 9 (6 39)
01□□AG7□1	36 (1 42)	38 (1 50)	26 (1 02)	36 (1 42)	20 (0 79)	12 5 (0 49)	10 55 (0 42)	M5 × 10L	32 (1 26)	3 5 (0 14)	6 (0 24)	6 (0 24)	2 9 (6 39)
02□□AG1□1	36 (1 42)	38 (1 50)	26 (1 02)	36 (1 42)	20 (0 79)	11 9 (0 47)	8 25 (0 32)	M5 × 10L	32 (1 26)	3 5 (0 14)	6 (0 24)	6 (0 24)	3 5 (7 72)
02□□AGB□1	36 (1 42)	38 (1 50)	26 (1 02)	36 (1 42)	20 (0 79)	11 9 (0 47)	8 25 (0 32)	M5 × 10L	32 (1 26)	3 5 (0 14)	6 (0 24)	6 (0 24)	3 6 (7 94)
02□□AGC□1	40 (1 57)	44 (1 73)	29 (1 14)	42 (1 65)	25 (0 98)	11 9 (0 47)	8 25 (0 32)	M6 × 12L	36 (1 42)	4 (0 16)	8 (0 31)	7 (0 28)	4 8 (10 6)
02□□AG7□1	40 (1 57)	44 (1 73)	29 (1 14)	42 (1 65)	25 (0 98)	11 9 (0 47)	8 25 (0 32)	M6 × 12L	36 (1 42)	4 (0 16)	8 (0 31)	7 (0 28)	4 8 (10 6)
04A□AG1□1	36 (1 42)	38 (1 50)	26 (1 02)	36 (1 42)	20 (0 79)	11 9 (0 47)	8 25 (0 32)	M5 × 10L	32 (1 26)	3 5 (0 14)	6 (0 24)	6 (0 24)	4 2 (9 26)
04A□AGB□1	40 (1 57)	44 (1 73)	29 (1 14)	42 (1 65)	25 (0 98)	11 9 (0 47)	8 25 (0 32)	M6 × 12L	36 (1 42)	4 (0 16)	8 (0 31)	7 (0 28)	5 5 (12 1)
04A□AGC□1	45 (1 77)	60 (2 36)	33 (1 30)	58 (2 28)	32 (1 26)	11 9 (0 47)	8 25 (0 32)	M8 × 16L	50 (1 97)	5 (0 20)	10 (0 39)	8 (0 31)	7 4 (16 3)
04A□AG7□1	45 (1 77)	60 (2 36)	33 (1 30)	58 (2 28)	32 (1 26)	11 9 (0 47)	8 25 (0 32)	M8 × 16L	50 (1 97)	5 (0 20)	10 (0 39)	8 (0 31)	7 4 (16 3)

Servodrive Dimensional Drawings

4 1 2 SGMPH Servomotors

Model SGMPH-	L1 mm (in)	L2 mm (in)	L3 mm (in)	Q mm (in)	S mm (in)	LF mm (in)	LH mm (in)	*Tap × depth	QK mm (in)	U mm (in)	W mm (in)	T mm (in)	Approx Mass kg (lb)
08A□AG1□1	40 (1 57)	44 (1 73)	29 (1 14)	42 (1 65)	25 (0 98)	12 8 (0 50)	10 5 (0 41)	M6 × 12L	36 (1 42)	4 (0 16)	8 (0 31)	7 (0 28)	7 3 (16 1)
08A□AGB□1	45 (1 77)	60 (2 36)	33 (1 30)	58 (2 28)	32 (1 26)	12 8 (0 50)	10 5 (0 41)	M8 × 16L	50 (1 97)	5 (0 20)	10 (0 39)	8 (0 31)	9 5 (20 9)
08A□AGC□1	57 (2 24)	85 (3 35)	42 (1 65)	82 (3 23)	40 (1 57)	12 8 (0 50)	10 5 (0 41)	M10 × 20L	70 (2 76)	5 (0 20)	12 (0 47)	8 (0 31)	13 9 (30 6)
08A□AG7□1	57 (2 24)	85 (3 35)	42 (1 65)	82 (3 23)	40 (1 57)	12 8 (0 50)	10 5 (0 41)	M10 × 20L	70 (2 76)	5 (0 20)	12 (0 47)	8 (0 31)	13 9 (30 6)
15A□AG1□1	45 (1 77)	60 (2 36)	33 (1 30)	58 (2 28)	32 (1 26)	12 8 (0 50)	10 5 (0 41)	M8 × 16L	50 (1 97)	5 (0 20)	10 (0 39)	8 (0 31)	12 6 (27 8)
15A□AGB□1	57 (2 24)	85 (3 35)	42 (1 65)	82 (3 23)	40 (1 57)	12 8 (0 50)	10 5 (0 41)	M10 × 20L	70 (2 76)	5 (0 20)	12 (0 47)	8 (0 31)	17 7 (39 0)
15A□AGC□1	70 (2 76)	86 (3 39)	51 (2 01)	82 (3 23)	45 (1 77)	12 8 (0 50)	10 5 (0 41)	M10 × 20L	70 (2 76)	5 5 (0 22)	14 (0 55)	9 (0 35)	23 6 (52 0)
15A□AG7□1	70 (2 76)	86 (3 39)	51 (2 01)	82 (3 23)	45 (1 77)	12 8 (0 50)	10 5 (0 41)	M10 × 20L	70 (2 76)	5 5 (0 22)	14 (0 55)	9 (0 35)	23 6 (52 0)

• Dimensional Tolerances

Model SGMPH-	Flange Face Dimensions mm (in)		Shaft-end Dimensions mm (in)	
	LB		S	
01□□AG1□1	65	$^{0}_{-0.030}$ (2 58)	16	$^{0}_{-0.018}$ (0 64)
01□□AGB□1	65	$^{0}_{-0.030}$ (2 58)	16	$^{0}_{-0.018}$ (0 64)
01□□AGC□1	85	$^{0}_{-0.035}$ (3 37)	20	$^{0}_{-0.021}$ (0 79)
01□□AG7□1	85	$^{0}_{-0.035}$ (3 37)	20	$^{0}_{-0.021}$ (0 79)
02□□AG1□1	85	$^{0}_{-0.035}$ (3 37)	20	$^{0}_{-0.021}$ (0 79)
02□□AGB□1	85	$^{0}_{-0.035}$ (3 37)	20	$^{0}_{-0.021}$ (0 79)
02□□AGC□1	100	$^{0}_{-0.035}$ (3 97)	25	$^{0}_{-0.021}$ (0 99)
02□□AG7□1	100	$^{0}_{-0.035}$ (3 97)	25	$^{0}_{-0.021}$ (0 99)
04A□AG1□1	85	$^{0}_{-0.035}$ (3 37)	20	$^{0}_{-0.021}$ (0 79)
04A□AGB□1	100	$^{0}_{-0.035}$ (3 97)	25	$^{0}_{-0.021}$ (0 99)
04A□AGC□1	115	$^{0}_{-0.035}$ (4 57)	32	$^{0}_{-0.025}$ (1 27)
04A□AG7□1	115	$^{0}_{-0.035}$ (4 57)	32	$^{0}_{-0.025}$ (1 27)
08A□AG1□1	100	$^{0}_{-0.035}$ (3 97)	25	$^{0}_{-0.021}$ (0 99)
08A□AGB□1	115	$^{0}_{-0.035}$ (4 57)	32	$^{0}_{-0.025}$ (1 27)
08A□AGC□1	140	$^{0}_{-0.040}$ (5 56)	40	$^{0}_{-0.025}$ (1 59)
08A□AG7□1	140	$^{0}_{-0.040}$ (5 56)	40	$^{0}_{-0.025}$ (1 59)

Model SGMPH-	Flange Face Dimensions mm (in)		Shaft-end Dimensions mm (in)	
	LB		S	
15A□AG1□1	115	$0_{-0.035} \left(4.57 - 0_{-0.0014} \right)$	32	$0_{-0.025} \left(1.27 - 0_{-0.0010} \right)$
15A□AGB□1	140	$0_{-0.040} \left(5.56 - 0_{-0.0016} \right)$	40	$0_{-0.025} \left(1.59 - 0_{-0.0010} \right)$
15A□AGC□1	165	$0_{-0.040} \left(6.55 - 0_{-0.0016} \right)$	45	$0_{-0.025} \left(1.79 - 0_{-0.0010} \right)$
15A□AG7□1	165	$0_{-0.040} \left(6.55 - 0_{-0.0016} \right)$	45	$0_{-0.025} \left(1.79 - 0_{-0.0010} \right)$

Table 4 19 Servomotors with Standard Backlash Gears (L to LZ) Units mm (in)

Model SGMPH-	Gear Ratio	L	LL	LM	LR	LE	LG	B	LD	LB	LC	LA	LZ
01□□AJ1□1	1/5	177 (6 97)	117 (4 61)	92 5 (3 64)	60 (2 36)	4 (0 16)	9 (0 35)	25 (0 98)	63 (2 48)	65 (2 56)	70 (2 76)	80 (3 15)	6 6 (0 26)
01□□AJ3□1	3/31	177 (6 97)	117 (4 61)	92 5 (3 64)	60 (2 36)	4 (0 16)	9 (0 35)	25 (0 98)	63 (2 48)	65 (2 56)	70 (2 76)	80 (3 15)	6 6 (0 26)
01□□AJC□1	1/21	195 5 (7 70)	121 5 (4 78)	97 (3 82)	74 (2 91)	4 (0 16)	10 (0 39)	32 (1 26)	83 (3 27)	85 (3 35)	90 (3 54)	105 (4 13)	9 (0 35)
01□□AJ7□1	1/33	195 5 (7 70)	121 5 (4 78)	97 (3 82)	74 (2 91)	4 (0 16)	10 (0 39)	32 (1 26)	83 (3 27)	85 (3 35)	90 (3 54)	105 (4 13)	9 (0 35)
02□□AJ1□1	1/5	200 5 (7 89)	126 5 (4 98)	102 6 (4 04)	74 (2 91)	4 (0 16)	10 (0 39)	32 (1 26)	83 (3 27)	85 (3 35)	90 (3 54)	105 (4 13)	9 (0 35)
02□□AJ3□1	3/31	200 5 (7 89)	126 5 (4 98)	102 6 (4 04)	74 (2 91)	4 (0 16)	10 (0 39)	32 (1 26)	83 (3 27)	85 (3 35)	90 (3 54)	105 (4 13)	9 (0 35)
02□□AJC□1	1/21	221 (8 70)	137 (5 39)	113 1 (4 45)	84 (3 31)	4 (0 16)	12 (0 47)	40 (1 57)	98 (3 86)	100 (3 94)	105 (4 13)	120 (4 72)	9 (0 35)
02□□AJ7□1	1/33	221 (8 70)	137 (5 39)	113 1 (4 45)	84 (3 31)	4 (0 16)	12 (0 47)	40 (1 57)	98 (3 86)	100 (3 94)	105 (4 13)	120 (4 72)	9 (0 35)
04A□AJ1□1	1/5	220 5 (8 68)	146 5 (5 77)	122 6 (4 83)	74 (2 91)	4 (0 16)	10 (0 39)	32 (1 26)	83 (3 27)	85 (3 35)	90 (3 54)	105 (4 13)	9 (0 35)
04A□AJ3□1	3/31	241 (9 49)	157 (6 18)	133 1 (5 24)	84 (3 31)	4 (0 16)	12 (0 47)	40 (1 57)	98 (3 86)	100 (3 94)	105 (4 13)	120 (4 72)	9 (0 35)
04A□AJC□1	1/21	269 (10 59)	164 (6 46)	140 1 (5 52)	105 (4 13)	5 (0 20)	13 (0 51)	50 (1 97)	112 (4 41)	115 (4 53)	120 (4 72)	135 (5 31)	11 (0 43)
04A□AJ7□1	1/33	269 (10 59)	164 (6 46)	140 1 (5 52)	105 (4 13)	5 (0 20)	13 (0 51)	50 (1 97)	112 (4 41)	115 (4 53)	120 (4 72)	135 (5 31)	11 (0 43)
08A□AJ1□1	1/5	240 5 (9 47)	156 5 (6 16)	131 7 (5 19)	84 (3 31)	4 (0 16)	12 (0 47)	40 (1 57)	98 (3 86)	100 (3 94)	105 (4 13)	120 (4 72)	9 (0 35)
08A□AJ3□1	3/31	268 5 (10 57)	163 5 (6 44)	138 7 (5 46)	105 (4 13)	5 (0 20)	13 (0 51)	50 (1 97)	112 (4 41)	115 (4 53)	120 (4 72)	135 (5 31)	11 (0 43)
08A□AJC□1	1/21	281 5 (11 08)	174 5 (6 87)	149 7 (5 89)	107 (4 21)	10 (0 39)	15 (0 59)	107 (4 21)	134 (5 28)	140 (5 51)	145 (5 71)	165 (6 50)	14 (0 55)
08A□AJ7□1	1/33	281 5 (11 08)	174 5 (6 87)	149 7 (5 89)	107 (4 21)	10 (0 39)	15 (0 59)	107 (4 21)	134 (5 28)	140 (5 51)	145 (5 71)	165 (6 50)	14 (0 55)
15A□AJ1□1	1/5	296 5 (11 67)	191 5 (7 54)	166 7 (6 56)	105 (4 13)	5 (0 20)	13 (0 51)	50 (1 97)	112 (4 41)	115 (4 53)	120 (4 72)	135 (5 31)	11 (0 43)
15A□AJB□1	15/167	309 5 (12 19)	202 5 (7 97)	177 7 (7 00)	107 (4 21)	10 (0 39)	15 (0 59)	107 (4 21)	134 (5 28)	140 (5 51)	145 (5 71)	165 (6 50)	14 (0 55)



Servodrive Dimensional Drawings

4 1 2 SGMPH Servomotors

Model SGMPH-	Gear Ratio	L	LL	LM	LR	LE	LG	B	LD	LB	LC	LA	LZ
15A□AJC□1	1/21	325.5 (12.81)	208.5 (8.21)	183.7 (7.23)	117 (4.61)	16 (0.63)	16 (0.63)	135 (5.31)	163 (6.42)	165 (6.50)	170 (6.69)	190 (7.48)	14 (0.55)
15A□AJ7□1	1/33	325.5 (12.81)	208.5 (8.21)	183.7 (7.23)	117 (4.61)	16 (0.63)	16 (0.63)	135 (5.31)	163 (6.42)	165 (6.50)	170 (6.69)	190 (7.48)	14 (0.55)

Table 4.20 Servomotors with Standard Backlash Gears (L1 to T) Units: mm (in)

Model SGMPH-	L1 mm (in)	L2 mm (in)	L3 mm (in)	Q mm (in)	S mm (in)	LF mm (in)	LH mm (in)	*Tap × depth	QK mm (in)	U mm (in)	W mm (in)	T mm (in)	Approx Mass kg (lb)
01□□AJ1□1	32 (1.26)	28 (1.10)	30 (1.18)	28 (1.10)	16 (0.63)	12.5 (0.49)	10.55 (0.42)	M4 × 8L	25 (0.98)	3 (0.12)	5 (0.20)	5 (0.20)	1.6 (3.53)
01□□AJ3□1	32 (1.26)	28 (1.10)	30 (1.18)	28 (1.10)	16 (0.63)	12.5 (0.49)	10.55 (0.42)	M4 × 8L	25 (0.98)	3 (0.12)	5 (0.20)	5 (0.20)	1.6 (3.53)
01□□AJC□1	38 (1.50)	36 (1.42)	36 (1.42)	36 (1.42)	20 (0.79)	12.5 (0.49)	10.55 (0.42)	M5 × 10L	32 (1.26)	3.5 (0.14)	6 (0.24)	6 (0.24)	2.6 (5.73)
01□□AJ7□1	38 (1.50)	36 (1.42)	36 (1.42)	36 (1.42)	20 (0.79)	12.5 (0.49)	10.55 (0.42)	M5 × 10L	32 (1.26)	3.5 (0.14)	6 (0.24)	6 (0.24)	2.6 (5.73)
02□□AJ1□1	38 (1.50)	36 (1.42)	36 (1.42)	36 (1.42)	20 (0.79)	11.9 (0.47)	8.25 (0.32)	M5 × 10L	32 (1.26)	3.5 (0.14)	6 (0.24)	6 (0.24)	3.4 (7.50)
02□□AJ3□1	38 (1.50)	36 (1.42)	36 (1.42)	36 (1.42)	20 (0.79)	11.9 (0.47)	8.25 (0.32)	M5 × 10L	32 (1.26)	3.5 (0.14)	6 (0.24)	6 (0.24)	3.4 (7.50)
02□□AJC□1	42 (1.65)	42 (1.65)	40 (1.57)	42 (1.65)	25 (0.98)	11.9 (0.47)	8.25 (0.32)	M6 × 12L	36 (1.42)	4 (0.16)	8 (0.31)	7 (0.28)	4.7 (10.4)
02□□AJ7□1	42 (1.65)	42 (1.65)	40 (1.57)	42 (1.65)	25 (0.98)	11.9 (0.47)	8.25 (0.32)	M6 × 12L	36 (1.42)	4 (0.16)	8 (0.31)	7 (0.28)	4.7 (10.4)
04A□AJ1□1	38 (1.50)	36 (1.42)	36 (1.42)	36 (1.42)	20 (0.79)	11.9 (0.47)	8.25 (0.32)	M5 × 10L	32 (1.26)	3.5 (0.14)	6 (0.24)	6 (0.24)	4.1 (9.04)
04A□AJ3□1	42 (1.65)	42 (1.65)	40 (1.57)	42 (1.65)	25 (0.98)	11.9 (0.47)	8.25 (0.32)	M6 × 12L	36 (1.42)	4 (0.16)	8 (0.31)	7 (0.28)	5.1 (11.2)
04A□AJC□1	47 (1.85)	58 (2.28)	45 (1.77)	58 (2.28)	32 (1.26)	11.9 (0.47)	8.25 (0.32)	M8 × 16L	50 (1.97)	5 (0.20)	10 (0.39)	8 (0.31)	6.9 (15.2)
04A□AJ7□1	47 (1.85)	58 (2.28)	45 (1.77)	58 (2.28)	32 (1.26)	11.9 (0.47)	8.25 (0.32)	M8 × 16L	50 (1.97)	5 (0.20)	10 (0.39)	8 (0.31)	6.9 (15.2)
08A□AJ1□1	42 (1.65)	42 (1.65)	40 (1.57)	42 (1.65)	25 (0.98)	12.8 (0.50)	10.5 (0.41)	M6 × 12L	36 (1.42)	4 (0.16)	8 (0.31)	7 (0.28)	7.5 (16.5)
08A□AJ3□1	47 (1.85)	58 (2.28)	45 (1.77)	58 (2.28)	32 (1.26)	12.8 (0.50)	10.5 (0.41)	M8 × 16L	50 (1.97)	5 (0.20)	10 (0.39)	8 (0.31)	9.0 (19.8)
08A□AJC□1	44 (1.73)	63 (2.48)	42 (1.65)	60 (2.36)	40 (1.57)	12.8 (0.50)	10.5 (0.41)	M10 × 20L	45 (1.77)	5 (0.20)	12 (0.47)	8 (0.31)	14.2 (31.3)
08A□AJ7□1	44 (1.73)	63 (2.48)	42 (1.65)	60 (2.36)	40 (1.57)	12.8 (0.50)	10.5 (0.41)	M10 × 20L	45 (1.77)	5 (0.20)	12 (0.47)	8 (0.31)	14.2 (31.3)
15A□AJ1□1	47 (1.85)	58 (2.28)	45 (1.77)	58 (2.28)	32 (1.26)	12.8 (0.50)	10.5 (0.41)	M8 × 16L	50 (1.97)	5 (0.20)	10 (0.39)	8 (0.31)	11.4 (25.1)
15A□AJB□1	44 (1.73)	63 (2.48)	42 (1.65)	60 (2.36)	40 (1.57)	12.8 (0.50)	10.5 (0.41)	M10 × 20L	45 (1.77)	5 (0.20)	12 (0.47)	8 (0.31)	16.6 (36.6)
15A□AJC□1	53 (2.09)	64 (2.52)	51 (2.01)	60 (2.36)	45 (1.77)	12.8 (0.50)	10.5 (0.41)	M10 × 20L	45 (1.77)	5.5 (0.22)	14 (0.55)	9 (0.35)	21.6 (47.6)
15A□AJ7□1	53 (2.09)	64 (2.52)	51 (2.01)	60 (2.36)	45 (1.77)	12.8 (0.50)	10.5 (0.41)	M10 × 20L	45 (1.77)	5.5 (0.22)	14 (0.55)	9 (0.35)	21.6 (47.6)

• Dimensional Tolerances

Model SGMPH-	Flange Face Dimensions mm (in)		Shaft-end Dimensions mm (in)	
	LB		S	
01□□AJ1□1	65	$2.58 - 0.0012$	16	$0.64 - 0.0007$
01□□AJ3□1	65	$2.58 - 0.0012$	16	$0.64 - 0.0007$
01□□AJC□1	85	$3.37 - 0.0014$	20	$0.79 - 0.0008$
01□□AJ7□1	85	$3.37 - 0.0014$	20	$0.79 - 0.0008$
02□□AJ1□1	85	$3.37 - 0.0014$	20	$0.79 - 0.0008$
02□□AJ3□1	85	$3.37 - 0.0014$	20	$0.79 - 0.0008$
02□□AJC□1	100	$3.97 - 0.0014$	25	$0.99 - 0.0008$
02□□AJ7□1	100	$3.97 - 0.0014$	25	$0.99 - 0.0008$
04A□AJ1□1	85	$3.37 - 0.0014$	20	$0.79 - 0.0008$
04A□AJ3□1	100	$3.97 - 0.0014$	25	$0.99 - 0.0008$
04A□AJC□1	115	$4.57 - 0.0014$	32	$1.27 - 0.0010$
04A□AJ7□1	115	$4.57 - 0.0014$	32	$1.27 - 0.0010$
08A□AJ1□1	100	$3.97 - 0.0014$	25	$0.99 - 0.0008$
08A□AJ3□1	115	$4.57 - 0.0014$	32	$1.27 - 0.0010$
08A□AJC□1	140	$5.56 - 0.0016$	40	$1.59 - 0.0010$
08A□AJ7□1	140	$5.56 - 0.0016$	40	$1.59 - 0.0010$
15A□AJ1□1	115	$4.57 - 0.0014$	32	$1.27 - 0.0010$
15A□AJ3□1	140	$5.56 - 0.0016$	40	$1.59 - 0.0010$
15A□AJC□1	165	$6.55 - 0.0016$	45	$1.79 - 0.0010$
15A□AJ7□1	165	$6.55 - 0.0016$	45	$1.79 - 0.0010$

Servomotor and Encoder Lead Specifications

The Servomotor and Encoder lead specifications are the same as those for standard Servomotors

■ Servomotors With Brakes

Either standard backlash or low-backlash gears are available

SGMPH: 100 W, 200 W, 400 W, 750 W, 1500 W With Brakes and Gears

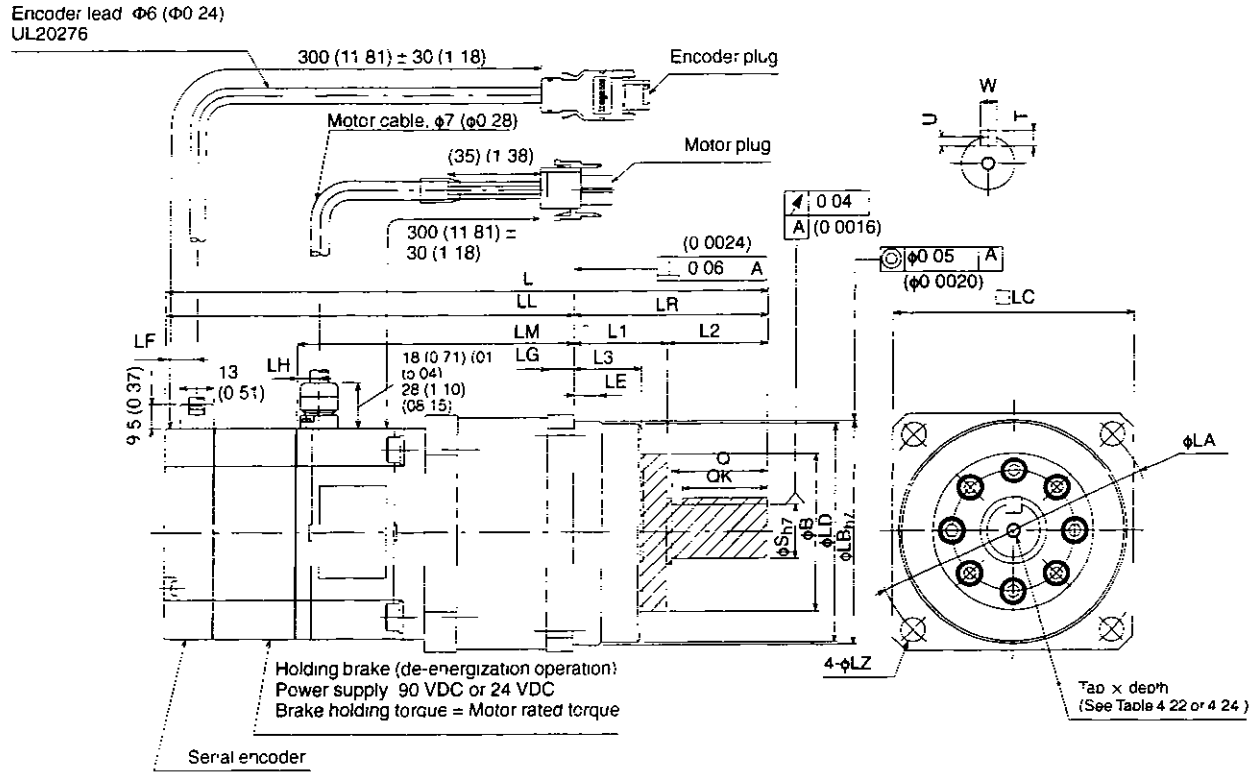

Table 4 21 Servomotors with Low-backlash Gears (L to LZ)

Units mm (in)

Model SGMPH-	Gear Ratio	L	LL	LM	LR	LE	LG	B	LD	LB	LC	LA	LZ
01□□AG1□□	1/5	198 (7 80)	138 (5 43)	89 5 (3 52)	60 (2 36)	8 (0 31)	9 (0 35)	50 (1 97)	64 5 (2 54)	65 (2 56)	70 (2 76)	80 (3 15)	6 6 (0 26)
01□□AGB□□	1/11	198 (7 80)	138 (5 43)	89 5 (3 52)	60 (2 36)	8 (0 31)	9 (0 35)	50 (1 97)	64 5 (2 54)	65 (2 56)	70 (2 76)	80 (3 15)	6 6 (0 26)
01□□AGC□□	1/21	221 (8 70)	147 (5 79)	98 5 (3 88)	74 (2 91)	10 (0 39)	10 (0 39)	60 (2 36)	83 (3 27)	85 (3 35)	90 (3 54)	105 (4 13)	9 (0 35)
01□□AG7□□	1/33	221 (8 70)	147 (5 79)	98 5 (3 88)	74 (2 91)	10 (0 39)	10 (0 39)	60 (2 36)	83 (3 27)	85 (3 35)	90 (3 54)	105 (4 13)	9 (0 35)
02□□AG1□□	1/5	228 5 (9 00)	154 5 (6 08)	104 1 (4 10)	74 (2 91)	10 (0 39)	10 (0 39)	60 (2 36)	83 (3 27)	85 (3 35)	90 (3 54)	105 (4 13)	9 (0 35)
02□□AGB□□	1/11	228 5 (9 00)	154 5 (6 08)	104 1 (4 10)	74 (2 91)	10 (0 39)	10 (0 39)	60 (2 36)	83 (3 27)	85 (3 35)	90 (3 54)	105 (4 13)	9 (0 35)
02□□AGC□□	1/21	246 5 (9 70)	162 5 (6 40)	112 1 (4 41)	84 (3 31)	12 (0 47)	12 (0 47)	70 (2 76)	96 (3 78)	100 (3 94)	105 (4 13)	120 (4 72)	9 (0 35)
02□□AG7□□	1/33	246 5 (9 70)	162 5 (6 40)	112 1 (4 41)	84 (3 31)	12 (0 47)	12 (0 47)	70 (2 76)	96 (3 78)	100 (3 94)	105 (4 13)	120 (4 72)	9 (0 35)
04A□AG1□□	1/5	248 5 (9 78)	174 5 (6 87)	124 1 (4 89)	74 (2 91)	10 (0 39)	10 (0 39)	60 (2 36)	83 (3 27)	85 (3 35)	90 (3 54)	105 (4 13)	9 (0 35)

Model SGMPH-	Gear Ratio	L	LL	LM	LR	LE	LG	B	LD	LB	LC	LA	LZ
04A□AGB□□	1/11	266.5 (10.49)	182.5 (7.19)	132.1 (5.20)	84 (3.31)	12 (0.47)	12 (0.47)	70 (2.76)	96 (3.78)	100 (3.94)	105 (4.13)	120 (4.72)	9 (0.35)
04A□AGC□□	1/21	295.5 (11.63)	190.5 (7.50)	140.1 (5.52)	105 (4.13)	14 (0.55)	13 (0.51)	90 (3.54)	112 (4.41)	115 (4.53)	120 (4.72)	135 (5.31)	11 (0.43)
04A□AG7□□	1/33	295.5 (11.63)	190.5 (7.50)	140.1 (5.52)	105 (4.13)	14 (0.55)	13 (0.51)	90 (3.54)	112 (4.41)	115 (4.53)	120 (4.72)	135 (5.31)	11 (0.43)
08A□AG1□□	1/5	271 (10.67)	187 (7.36)	130.7 (5.15)	84 (3.31)	12 (0.47)	12 (0.47)	70 (2.76)	96 (3.78)	100 (3.94)	105 (4.13)	120 (4.72)	9 (0.35)
08A□AGB□□	1/11	297 (11.69)	192 (7.56)	138.7 (5.46)	105 (4.13)	14 (0.55)	13 (0.51)	90 (3.54)	112 (4.41)	115 (4.53)	120 (4.72)	135 (5.31)	11 (0.43)
08A□AGC□□	1/21	350 (13.78)	208 (8.19)	154.7 (6.09)	142 (5.59)	10 (0.39)	15 (0.59)	100 (3.94)	134 (5.28)	140 (5.51)	145 (5.71)	165 (6.50)	14 (0.55)
08A□AG7□□	1/33	350 (13.78)	208 (8.19)	154.7 (6.09)	142 (5.59)	10 (0.39)	15 (0.59)	100 (3.94)	134 (5.28)	140 (5.51)	145 (5.71)	165 (6.50)	14 (0.55)
15A□AG1□□	1/5	328 (12.91)	223 (8.78)	166.7 (6.56)	105 (4.13)	14 (0.55)	13 (0.51)	90 (3.54)	112 (4.41)	115 (4.53)	120 (4.72)	135 (5.31)	11 (0.43)
15A□AGB□□	1/11	381 (15.00)	239 (9.41)	182.7 (7.19)	142 (5.59)	10 (0.39)	15 (0.59)	100 (3.94)	134 (5.28)	140 (5.51)	145 (5.71)	165 (6.50)	14 (0.55)
15A□AGC□□	1/21	401 (15.79)	245 (9.65)	188.7 (7.43)	156 (6.14)	16 (0.63)	16 (0.63)	135 (5.31)	163 (6.42)	165 (6.50)	170 (6.69)	190 (7.48)	14 (0.55)
15A□AG7□□	1/33	401 (15.79)	245 (9.65)	188.7 (7.43)	156 (6.14)	16 (0.63)	16 (0.63)	135 (5.31)	163 (6.42)	165 (6.50)	170 (6.69)	190 (7.48)	14 (0.55)

Table 4 22 Servomotors with Low-backlash Gears (L1 to T)

Units mm (in)

Model SGMPH-	L1 mm (in)	L2 mm (in)	L3 mm (in)	Q mm (in)	S mm (in)	LF mm (in)	LH mm (in)	*Tap × depth	QK mm (in)	U mm (in)	W mm (in)	T mm (in)	Approx Mass kg (lb)
01□□AG1□□	30 (1.18)	30 (1.18)	22 (0.87)	28 (1.10)	16 (0.63)	12.5 (0.49)	10.55 (0.42)	M4 × 8L	25 (0.98)	3 (0.12)	5 (0.20)	5 (0.20)	1.9 (4.19)
01□□AGB□□	30 (1.18)	30 (1.18)	22 (0.87)	28 (1.10)	16 (0.63)	12.5 (0.49)	10.55 (0.42)	M4 × 8L	25 (0.98)	3 (0.12)	5 (0.20)	5 (0.20)	2.0 (4.41)
01□□AGC□□	36 (1.42)	38 (1.50)	26 (1.02)	36 (1.42)	20 (0.79)	12.5 (0.49)	10.55 (0.42)	M5 × 10L	32 (1.26)	3.5 (0.14)	6 (0.24)	6 (0.24)	3.1 (6.83)
01□□AG7□□	36 (1.42)	38 (1.50)	26 (1.02)	36 (1.42)	20 (0.79)	12.5 (0.49)	10.55 (0.42)	M5 × 10L	32 (1.26)	3.5 (0.14)	6 (0.24)	6 (0.24)	3.1 (6.83)
02□□AG1□□	36 (1.42)	38 (1.50)	26 (1.02)	36 (1.42)	20 (0.79)	11.9 (0.47)	8.25 (0.32)	M5 × 10L	32 (1.26)	3.5 (0.14)	6 (0.24)	6 (0.24)	4.0 (8.82)
02□□AGB□□	36 (1.42)	38 (1.50)	26 (1.02)	36 (1.42)	20 (0.79)	11.9 (0.47)	8.25 (0.32)	M5 × 10L	32 (1.26)	3.5 (0.14)	6 (0.24)	6 (0.24)	4.1 (9.04)
02□□AGC□□	40 (1.57)	44 (1.73)	29 (1.14)	42 (1.65)	25 (0.98)	11.9 (0.47)	8.25 (0.32)	M6 × 12L	36 (1.42)	4 (0.16)	8 (0.31)	7 (0.28)	5.3 (11.7)
02□□AG7□□	40 (1.57)	44 (1.73)	29 (1.14)	42 (1.65)	25 (0.98)	11.9 (0.47)	8.25 (0.32)	M6 × 12L	36 (1.42)	4 (0.16)	8 (0.31)	7 (0.28)	5.3 (11.7)
04A□AG1□□	36 (1.42)	38 (1.50)	26 (1.02)	36 (1.42)	20 (0.79)	11.9 (0.47)	8.25 (0.32)	M5 × 10L	32 (1.26)	3.5 (0.14)	6 (0.24)	6 (0.24)	4.7 (10.4)
04A□AGB□□	40 (1.57)	44 (1.73)	29 (1.14)	42 (1.65)	25 (0.98)	11.9 (0.47)	8.25 (0.32)	M6 × 12L	36 (1.42)	4 (0.16)	8 (0.31)	7 (0.28)	6.0 (13.2)
04A□AGC□□	45 (1.77)	60 (2.36)	33 (1.30)	58 (2.28)	32 (1.26)	11.9 (0.47)	8.25 (0.32)	M8 × 16L	50 (1.97)	5 (0.20)	10 (0.39)	8 (0.31)	7.9 (17.4)

Model SGMPH-	L1 mm (in)	L2 mm (in)	L3 mm (in)	Q mm (in)	S mm (in)	LF mm (in)	LH mm (in)	*Tap × depth	QK mm (in)	U mm (in)	W mm (in)	T mm (in)	Approx. Mass kg (lb)
04A□AG7□□	45 (1 77)	60 (2 36)	33 (1 30)	58 (2 28)	32 (1 26)	11 9 (0 47)	8 25 (0 32)	M8 × 16L	50 (1 97)	5 (0 20)	10 (0 39)	8 (0 31)	7 9 (17 4)
08A□AG1□□	40 (1 57)	44 (1 73)	29 (1 14)	42 (1 65)	25 (0 98)	12 8 (0 50)	10 5 (0 41)	M6 × 12L	36 (1 42)	4 (0 16)	8 (0 31)	7 (0 28)	8 8 (19 4)
08A□AGB□□	45 (1 77)	60 (2 36)	33 (1 30)	58 (2 28)	32 (1 26)	12 8 (0 50)	10 5 (0 41)	M8 × 16L	50 (1 97)	5 (0 20)	10 (0 39)	8 (0 31)	11 0 (24 3)
08A□AGC□□	57 (2 24)	85 (3 35)	42 (1 65)	82 (3 23)	40 (1 57)	12 8 (0 50)	10 5 (0 41)	M10 × 20L	70 (2 76)	5 (0 20)	12 (0 47)	8 (0 31)	15 4 (34 0)
08A□AG7□□	57 (2 24)	85 (3 35)	42 (1 65)	82 (3 23)	40 (1 57)	12 8 (0 50)	10 5 (0 41)	M10 × 20L	70 (2 76)	5 (0 20)	12 (0 47)	8 (0 31)	15 4 (34 0)
15A□AG1□□	45 (1 77)	60 (2 36)	33 (1 30)	58 (2 28)	32 (1 26)	12 8 (0 50)	10 5 (0 41)	M8 × 16L	50 (1 97)	5 (0 20)	10 (0 39)	8 (0 31)	14 1 (31 1)
15A□AGB□□	57 (2 24)	85 (3 35)	42 (1 65)	82 (3 23)	40 (1 57)	12 8 (0 50)	10 5 (0 41)	M10 × 20L	70 (2 76)	5 (0 20)	12 (0 47)	8 (0 31)	19 2 (42 3)
15A□AGC□□	70 (2 76)	86 (3 39)	51 (2 01)	82 (3 23)	45 (1 77)	12 8 (0 50)	10 5 (0 41)	M10 × 20L	70 (2 76)	5 5 (0 22)	14 (0 55)	9 (0 35)	25 1 (55 3)
15A□AG7□□	70 (2 76)	86 (3 39)	51 (2 01)	82 (3 23)	45 (1 77)	12 8 (0 50)	10 5 (0 41)	M10 × 20L	70 (2 76)	5 5 (0 22)	14 (0 55)	9 (0 35)	25 1 (55 3)

• Dimensional Tolerances

Model SGMPH-	Flange Face Dimensions mm (in)		Shaft-end Dimensions mm (in)	
	LB		S	
01□□AG1□□	65	$0_{-0.030} \left(2.58 - \frac{0}{0.0012} \right)$	16	$0_{-0.018} \left(0.64 - \frac{0}{0.0007} \right)$
01□□AGB□□	65	$0_{-0.030} \left(2.58 - \frac{0}{0.0012} \right)$	16	$0_{-0.018} \left(0.64 - \frac{0}{0.0007} \right)$
01□□AGC□□	85	$0_{-0.035} \left(3.37 - \frac{0}{0.0014} \right)$	20	$0_{-0.021} \left(0.79 - \frac{0}{0.0008} \right)$
01□□AG7□□	85	$0_{-0.035} \left(3.37 - \frac{0}{0.0014} \right)$	20	$0_{-0.021} \left(0.79 - \frac{0}{0.0008} \right)$
02□□AG1□□	85	$0_{-0.035} \left(3.37 - \frac{0}{0.0014} \right)$	20	$0_{-0.021} \left(0.79 - \frac{0}{0.0008} \right)$
02□□AGB□□	85	$0_{-0.035} \left(3.37 - \frac{0}{0.0014} \right)$	20	$0_{-0.021} \left(0.79 - \frac{0}{0.0008} \right)$
02□□AGC□□	100	$0_{-0.035} \left(3.97 - \frac{0}{0.0014} \right)$	25	$0_{-0.021} \left(0.99 - \frac{0}{0.0008} \right)$
02□□AG7□□	100	$0_{-0.035} \left(3.97 - \frac{0}{0.0014} \right)$	25	$0_{-0.021} \left(0.99 - \frac{0}{0.0008} \right)$
04A□AG1□□	85	$0_{-0.035} \left(3.37 - \frac{0}{0.0014} \right)$	20	$0_{-0.021} \left(0.79 - \frac{0}{0.0008} \right)$
04A□AGB□□	100	$0_{-0.035} \left(3.97 - \frac{0}{0.0014} \right)$	25	$0_{-0.021} \left(0.99 - \frac{0}{0.0008} \right)$
04A□AGC□□	115	$0_{-0.035} \left(4.57 - \frac{0}{0.0014} \right)$	32	$0_{-0.025} \left(1.27 - \frac{0}{0.0010} \right)$
04A□AG7□□	115	$0_{-0.035} \left(4.57 - \frac{0}{0.0014} \right)$	32	$0_{-0.025} \left(1.27 - \frac{0}{0.0010} \right)$
08A□AG1□□	100	$0_{-0.035} \left(3.97 - \frac{0}{0.0014} \right)$	25	$0_{-0.021} \left(0.99 - \frac{0}{0.0008} \right)$
08A□AGB□□	115	$0_{-0.035} \left(4.57 - \frac{0}{0.0014} \right)$	32	$0_{-0.025} \left(1.27 - \frac{0}{0.0010} \right)$
08A□AGC□□	140	$0_{-0.040} \left(5.56 - \frac{0}{0.0016} \right)$	40	$0_{-0.025} \left(1.59 - \frac{0}{0.0010} \right)$

Model SGMPH-	Flange Face Dimensions mm (in)	Shaft-end Dimensions mm (in)
	LB	S
08A□AG7□□	140 $_{-0.040}^0$ (5 56 $_{-0.0016}^0$)	40 $_{-0.025}^0$ (1 59 $_{-0.0010}^0$)
15A□AG1□□	115 $_{-0.035}^0$ (4 57 $_{-0.0014}^0$)	32 $_{-0.025}^0$ (1 27 $_{-0.0010}^0$)
15A□AGB□□	140 $_{-0.040}^0$ (5 56 $_{-0.0016}^0$)	40 $_{-0.025}^0$ (1 59 $_{-0.0010}^0$)
15A□AGC□□	165 $_{-0.040}^0$ (6 55 $_{-0.0016}^0$)	45 $_{-0.025}^0$ (1 79 $_{-0.0010}^0$)
15A□AG7□□	165 $_{-0.040}^0$ (6 55 $_{-0.0016}^0$)	45 $_{-0.025}^0$ (1 79 $_{-0.0010}^0$)

Table 4.23 Servomotors with Standard Backlash Gears (L to LZ)

Units mm (in)

Model SGMPH-	Gear Ratio	L	LL	LM	LR	LE	LG	B	LD	LB	LC	LA	LZ
01□□AJ1□□	1/5	206 (8 11)	146 (5 75)	92 5 (3 64)	60 (2 36)	4 (0 16)	9 (0 35)	25 (0 98)	63 (2 48)	65 (2 56)	70 (2 76)	80 (3 15)	6 6 (0 26)
01□□AJ3□□	3/31	206 (8 11)	146 (5 75)	92 5 (3 64)	60 (2 36)	4 (0 16)	9 (0 35)	25 (0 98)	63 (2 48)	65 (2 56)	70 (2 76)	80 (3 15)	6 6 (0 26)
01□□AJC□□	1/21	224 5 (8 84)	150 5 (5 93)	97 (3 82)	74 (2 91)	4 (0 16)	10 (0 39)	32 (1 26)	83 (3 27)	85 (3 35)	90 (3 54)	105 (4 13)	9 (0 35)
01□□AJ7□□	1/33	224 5 (8 84)	150 5 (5 93)	97 (3 82)	74 (2 91)	4 (0 16)	10 (0 39)	32 (1 26)	83 (3 27)	85 (3 35)	90 (3 54)	105 (4 13)	9 (0 35)
02□□AJ1□□	1/5	232 (9 13)	158 (6 22)	102 6 (4 04)	74 (2 91)	4 (0 16)	10 (0 39)	32 (1 26)	83 (3 27)	85 (3 35)	90 (3 54)	105 (4 13)	9 (0 35)
02□□AJ3□□	3/31	232 (9 13)	158 (6 22)	102 6 (4 04)	74 (2 91)	4 (0 16)	10 (0 39)	32 (1 26)	83 (3 27)	85 (3 35)	90 (3 54)	105 (4 13)	9 (0 35)
02□□AJC□□	1/21	252 5 (9 94)	168 5 (6 63)	113 1 (4 45)	84 (3 31)	4 (0 16)	12 (0 47)	40 (1 57)	98 (3 86)	100 (3 94)	105 (4 13)	120 (4 72)	9 (0 35)
02□□AJ7□□	1/33	252 5 (9 94)	168 5 (6 63)	113 1 (4 45)	84 (3 31)	4 (0 16)	12 (0 47)	40 (1 57)	98 (3 86)	100 (3 94)	105 (4 13)	120 (4 72)	9 (0 35)
04A□AJ1□□	1/5	252 (9 92)	178 (7 01)	122 6 (4 83)	74 (2 91)	4 (0 16)	10 (0 39)	32 (1 26)	83 (3 27)	85 (3 35)	90 (3 54)	105 (4 13)	9 (0 35)
04A□AJ3□□	3/31	272 5 (10 73)	188 5 (7 42)	133 1 (5 24)	84 (3 31)	4 (0 16)	12 (0 47)	40 (1 57)	98 (3 86)	100 (3 94)	105 (4 13)	120 (4 72)	9 (0 35)
04A□AJC□□	1/21	300 5 (11 83)	195 5 (7 70)	140 1 (5 52)	105 (4 13)	5 (0 20)	13 (0 51)	50 (1 97)	112 (4 41)	115 (4 53)	120 (4 72)	120 (4 72)	11 (0 43)
04A□AJ7□□	1/33	300 5 (11 83)	195 5 (7 70)	140 1 (5 52)	105 (4 13)	5 (0 20)	13 (0 51)	50 (1 97)	112 (4 41)	115 (4 53)	120 (4 72)	105 (4 13)	11 (0 43)
08A□AJ1□□	1/5	277 (10 91)	193 (7 60)	131 7 (5 19)	84 (3 31)	4 (0 16)	12 (0 47)	40 (1 57)	98 (3 86)	100 (3 94)	105 (4 13)	120 (4 72)	9 (0 35)
08A□AJ3□□	3/31	305 (12 01)	200 (7 87)	138 7 (5 46)	105 (4 13)	5 (0 20)	13 (0 51)	50 (1 97)	112 (4 41)	115 (4 53)	120 (4 72)	135 (5 31)	11 (0 43)
08A□AJC□□	1/21	318 (12 52)	211 (8 31)	149 7 (5 89)	107 (4 21)	10 (0 39)	15 (0 59)	107 (4 21)	134 (5 28)	140 (5 51)	145 (5 71)	135 (5 31)	14 (0 55)
08A□AJ7□□	1/33	318 (12 52)	211 (8 31)	149 7 (5 89)	107 (4 21)	10 (0 39)	15 (0 59)	107 (4 21)	134 (5 28)	140 (5 51)	145 (5 71)	120 (4 72)	14 (0 55)
15A□AJ1□□	1/5	333 (13 11)	228 (8 98)	166 7 (6 56)	105 (4 13)	5 (0 20)	13 (0 51)	50 (1 97)	112 (4 41)	115 (4 53)	120 (4 72)	135 (5 31)	11 (0 43)
15A□AJB□□	15/167	346 (13 62)	239 (9 41)	177 7 (7 00)	107 (4 21)	10 (0 39)	15 (0 59)	107 (4 21)	134 (5 28)	140 (5 51)	145 (5 71)	165 (6 50)	14 (0 55)

Servodrive Dimensional Drawings

4 1 2 SGMPH Servomotors

Model SGMPH-	Gear Ratio	L	LL	LM	LR	LE	LG	B	LD	LB	LC	LA	LZ
15A□AJC□□	1/21	362 (14 25)	245 (9 65)	183 7 (7 23)	117 (4 61)	16 (0 63)	16 (0 63)	135 (5 31)	163 (6 42)	165 (6 50)	170 (6 69)	190 (7 48)	14 (0 55)
15A□AJ7□□	1/33	362 (14 25)	245 (9 65)	183 7 (7 23)	117 (4 61)	16 (0 63)	16 (0 63)	135 (5 31)	163 (6 42)	165 (6 50)	170 (6 69)	190 (7 48)	14 (0 55)

Table 4.24 Servomotors with Standard Backlash Gears (L1 to T)

Units mm (in)

Model SGMPH-	L1 mm (in)	L2 mm (in)	L3 mm (in)	Q mm (in)	S mm (in)	LF mm (in)	LH mm (in)	*Tap × depth	QK mm (in)	U mm (in)	W mm (in)	T mm (in)	Approx Mass kg (lb)
01□□AJ1□□	32 (1 26)	28 (1 10)	30 (1 18)	28 (1 10)	16 (0 63)	12 5 (0 49)	10 55 (0 42)	M4 × 8L	25 (0 98)	3 (0 12)	5 (0 20)	5 (0 20)	1 8 (3 97)
01□□AJ3□□	32 (1 26)	28 (1 10)	30 (1 18)	28 (1 10)	16 (0 63)	12 5 (0 49)	10 55 (0 42)	M4 × 8L	25 (0 98)	3 (0 12)	5 (0 20)	5 (0 20)	1 8 (3 97)
01□□AJC□□	38 (1 50)	36 (1 42)	36 (1 42)	36 (1 42)	20 (0 79)	12 5 (0 49)	10 55 (0 42)	M5 × 10L	32 (1 26)	3 5 (0 14)	6 (0 24)	6 (0 24)	2 8 (6 17)
01□□AJ7□□	38 (1 50)	36 (1 42)	36 (1 42)	36 (1 42)	20 (0 79)	12 5 (0 49)	10 55 (0 42)	M5 × 10L	32 (1 26)	3 5 (0 14)	6 (0 24)	6 (0 24)	2 8 (6 17)
02□□AJ1□□	38 (1 50)	36 (1 42)	36 (1 42)	36 (1 42)	20 (0 79)	11 9 (0 47)	8 25 (0 32)	M5 × 10L	32 (1 26)	3 5 (0 14)	6 (0 24)	6 (0 24)	3 9 (8 60)
02□□AJ3□□	38 (1 50)	36 (1 42)	36 (1 42)	36 (1 42)	20 (0 79)	11 9 (0 47)	8 25 (0 32)	M5 × 10L	32 (1 26)	3 5 (0 14)	6 (0 24)	6 (0 24)	3 9 (8 60)
02□□AJC□□	42 (1 65)	42 (1 65)	40 (1 57)	42 (1 65)	25 (0 98)	11 9 (0 47)	8 25 (0 32)	M6 × 12L	36 (1 42)	4 (0 16)	8 (0 31)	7 (0 28)	5 2 (11 5)
02□□AJ7□□	42 (1 65)	42 (1 65)	40 (1 57)	42 (1 65)	25 (0 98)	11 9 (0 47)	8 25 (0 32)	M6 × 12L	36 (1 42)	4 (0 16)	8 (0 31)	7 (0 28)	5 2 (11 5)
04A□AJ1□□	38 (1 50)	36 (1 42)	36 (1 42)	36 (1 42)	20 (0 79)	11 9 (0 47)	8 25 (0 32)	M5 × 10L	32 (1 26)	3 5 (0 14)	6 (0 24)	6 (0 24)	4 6 (10 1)
04A□AJ3□□	42 (1 65)	42 (1 65)	40 (1 57)	42 (1 65)	25 (0 98)	11 9 (0 47)	8 25 (0 32)	M6 × 12L	36 (1 42)	4 (0 16)	8 (0 31)	7 (0 28)	5 6 (12 3)
04A□AJC□□	47 (1 85)	58 (2 28)	45 (1 77)	58 (2 28)	32 (1 26)	11 9 (0 47)	8 25 (0 32)	M8 × 16L	50 (1 97)	5 (0 20)	10 (0 39)	8 (0 31)	7 4 (16 3)
04A□AJ7□□	47 (1 85)	58 (2 28)	45 (1 77)	58 (2 28)	32 (1 26)	11 9 (0 47)	8 25 (0 32)	M8 × 16L	50 (1 97)	5 (0 20)	10 (0 39)	8 (0 31)	7 4 (16 3)
08A□AJ1□□	42 (1 65)	42 (1 65)	40 (1 57)	42 (1 65)	25 (0 98)	12 8 (0 50)	10 5 (0 41)	M6 × 12L	36 (1 42)	4 (0 16)	8 (0 31)	7 (0 28)	9 0 (19 8)
08A□AJ3□□	47 (1 85)	58 (2 28)	45 (1 77)	58 (2 28)	32 (1 26)	12 8 (0 50)	10 5 (0 41)	M8 × 16L	50 (1 97)	5 (0 20)	10 (0 39)	8 (0 31)	10 5 (23 1)
08A□AJC□□	44 (1 73)	63 (2 48)	42 (1 65)	60 (2 36)	40 (1 57)	12 8 (0 50)	10 5 (0 41)	M10 × 20L	45 (1 77)	5 (0 20)	12 (0 47)	8 (0 31)	15 7 (34 6)
08A□AJ7□□	44 (1 73)	63 (2 48)	42 (1 65)	60 (2 36)	40 (1 57)	12 8 (0 50)	10 5 (0 41)	M10 × 20L	45 (1 77)	5 (0 20)	12 (0 47)	8 (0 31)	15 7 (34 6)
15A□AJ1□□	47 (1 85)	58 (2 28)	45 (1 77)	58 (2 28)	32 (1 26)	12 8 (0 50)	10 5 (0 41)	M8 × 16L	50 (1 97)	5 (0 20)	10 (0 39)	8 (0 31)	12 9 (28 4)
15A□AJB□□	44 (1 73)	63 (2 48)	42 (1 65)	60 (2 36)	40 (1 57)	12 8 (0 50)	10 5 (0 41)	M10 × 20L	45 (1 77)	5 (0 20)	12 (0 47)	8 (0 31)	18 1 (39 9)
15A□AJC□□	53 (2 09)	64 (2 52)	51 (2 01)	60 (2 36)	45 (1 77)	12 8 (0 50)	10 5 (0 41)	M10 × 20L	45 (1 77)	5 5 (0 22)	14 (0 55)	9 (0 35)	23 1 (50 9)
15A□AJ7□□	53 (2 09)	64 (2 52)	51 (2 01)	60 (2 36)	45 (1 77)	12 8 (0 50)	10 5 (0 41)	M10 × 20L	45 (1 77)	5 5 (0 22)	14 (0 55)	9 (0 35)	23 1 (50 9)

• Dimensional Tolerances

Model SGMPH-	Flange Face Dimensions mm (in)		Shaft-end Dimensions mm (in)	
	LB		S	
01□□AJ1□□	65	$2.58 - 0.0012$	16	$0.64 - 0.0007$
01□□AJ3□□	65	$2.58 - 0.0012$	16	$0.64 - 0.0007$
01□□AJC□□	85	$3.37 - 0.0014$	20	$0.79 - 0.0008$
01□□AJ7□□	85	$3.37 - 0.0014$	20	$0.79 - 0.0008$
02□□AJ1□□	85	$3.37 - 0.0014$	20	$0.79 - 0.0008$
02□□AJ3□□	85	$3.37 - 0.0014$	20	$0.79 - 0.0008$
02□□AJC□□	100	$3.97 - 0.0014$	25	$0.99 - 0.0008$
02□□AJ7□□	100	$3.97 - 0.0014$	25	$0.99 - 0.0008$
04A□AJ1□□	85	$3.37 - 0.0014$	20	$0.79 - 0.0008$
04A□AJ3□□	100	$3.97 - 0.0014$	25	$0.99 - 0.0008$
04A□AJC□□	115	$4.57 - 0.0014$	32	$1.27 - 0.0010$
04A□AJ7□□	115	$4.57 - 0.0014$	32	$1.27 - 0.0010$
08A□AJ1□□	100	$3.97 - 0.0014$	25	$0.99 - 0.0008$
08A□AJ3□□	115	$4.57 - 0.0014$	32	$1.27 - 0.0010$
08A□AJC□□	140	$5.56 - 0.0016$	40	$1.59 - 0.0010$
08A□AJ7□□	140	$5.56 - 0.0016$	40	$1.59 - 0.0010$
15A□AJ1□□	115	$4.57 - 0.0014$	32	$1.27 - 0.0010$
15A□AJ3□□	140	$5.56 - 0.0016$	40	$1.59 - 0.0010$
15A□AJC□□	165	$6.55 - 0.0016$	45	$1.79 - 0.0010$
15A□AJ7□□	165	$6.55 - 0.0016$	45	$1.79 - 0.0010$

Servomotor and Encoder Lead Specifications

The Servomotor and Encoder lead specifications are the same as those for standard Servomotors

4.1.3 SGMGH Servomotors (1500 r/min)

■ **SGMGH-□□ A2A Servomotors with 17-bit Absolute Encoders and SGMGH-□□ ACA Servomotors with 17-bit Incremental Encoders**

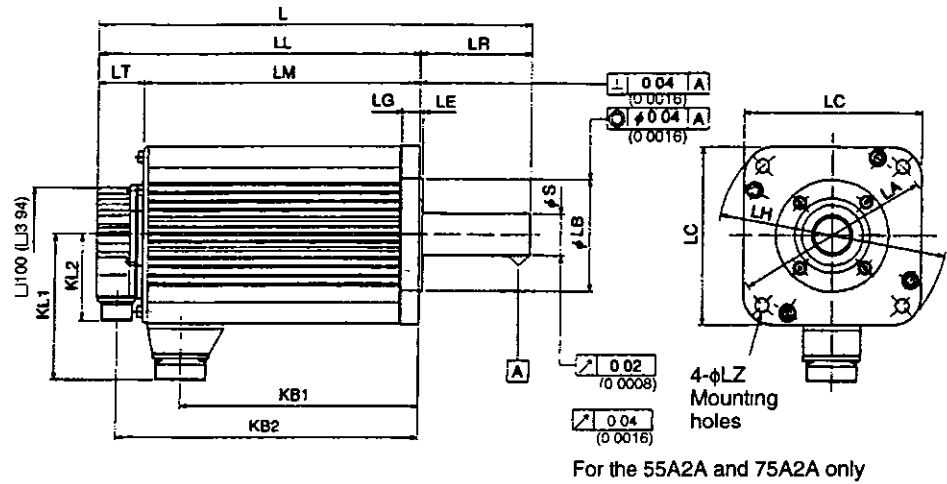

Enlarged View of Shaft End

SGMGH-05A2A to 13A2A
SGMGH-05ACA to 13ACA

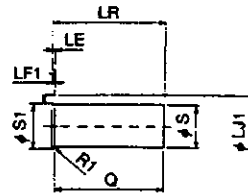

SGMGH-20A2A to 75A2A
SGMGH-20ACA to 75ACA

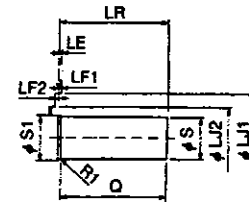

Table 4 25 SGMGH-□□ A2A Servomotors with 17-bit Absolute Encoders and SGMGH-□□ ACA Servomotors with 17-bit Incremental Encoders (L to KL2)

Units mm (in)

Model SGMGH-	L	LL	LM	LR	LT	KB1	KB2	IE	KL1	KL2
05A□A	196 (7 72)	138 (5 43)	92 (3 62)	58 (2 28)	46 (1 81)	65 (2 56)	117 (4 61)	-	109 (4 29)	88 (3 46)
09A□A	219 (8 62)	161 (6 34)	115 (4 53)	58 (2 28)	46 (1 81)	88 (3 46)	140 (5 51)	-	109 (4 29)	88 (3 46)
13A□A	243 (9 57)	185 (7 28)	139 (5 47)	58 (2 28)	46 (1 81)	112 (4 41)	164 (6 46)	-	109 (4 29)	88 (3 46)
20A□A	245 (9 65)	166 (6 54)	119 (4 69)	79 (3 11)	47 (1 85)	89 (3 50)	145 (5 71)	-	140 (5 51)	88 (3 46)
30A□A	271 (10 67)	192 (7 56)	145 (5 71)	79 (3 11)	47 (1 85)	115 (4 53)	171 (6 73)	-	140 (5 51)	88 (3 46)
44A□A	305 (12)	226 (8 9)	179 (7 05)	79 (3 11)	47 (1 85)	149 (5 87)	205 (8 07)	-	140 (5 51)	88 (3 46)

Model SGMGH-	L	LL	LM	LR	LT	KB1	KB2	IE	KL1	KL2
55A□A	373 (14 7)	260 (10 2)	213 (8 39)	113 (4 45)	47 (1 85)	174 (6 85)	239 (9 41)	125 (4 92)	150 (5 91)	88 (3 46)
75A□A	447 (17 6)	334 (13 1)	287 (11 3)	113 (4 45)	47 (1 85)	248 (9 76)	313 (12 3)	125 (4 92)	150 (5 91)	88 (3 46)
1AA□A	454 (17 9)	338 (13 3)	291 (11 5)	116 (4 57)	47 (1 85)	251 (9 88)	317 (12 5)	142 (5 59)	168 (6 61)	88 (3 46)
1EA□A	573 (22 6)	457 (18 0)	388 (15 3)	116 (4 57)	69 (2 72)	343 (13 5)	435 (17 1)	142 (5 59)	168 (6 61)	88 (3 46)

Table 4.26 SGMGH-□□ A2A Servomotors with 17-bit Absolute Encoders and
SGMGH-□□ ACA Servomotors with 17-bit Incremental Encoders (LA to Q)

Model SGMGH-	Flange Face Dimensions mm (in)											Shaft-end Dimensions mm (in)			Approx. Mass kg (lb)
	LA	LB	LC	LE	LF1	LF2	LG	LH	LJ1	LJ2	LZ	S	S1	Q	
05A□A	145 (5 71)	$\begin{matrix} 0 \\ 110 - 0.035 \\ 0 \\ (4.33 - 0.0014) \end{matrix}$	130 (5 12)	6 (0 24)	6 (0 24)	-	12 (0 47)	165 (6 50)	45 (1 77)	-	9 (0 35)	$\begin{matrix} 0 \\ 19 - 0.013 \\ 0 \\ (0.75 - 0.0005) \end{matrix}$	30 (1 18)	40 (1 57)	5 5 (12 1)
09A□A	145 (5 71)	$\begin{matrix} 0 \\ 110 - 0.035 \\ 0 \\ (4.33 - 0.0014) \end{matrix}$	130 (5 12)	6 (0 24)	6 (0 24)	-	12 (0 47)	165 (6 50)	45 (1 77)	-	9 (0 35)	$\begin{matrix} 0 \\ 19 - 0.013 \\ 0 \\ (0.75 - 0.0005) \end{matrix}$	30 (1 18)	40 (1 57)	7 6 (16 8)
13A□A	145 (5 71)	$\begin{matrix} 0 \\ 110 - 0.035 \\ 0 \\ (4.33 - 0.0014) \end{matrix}$	130 (5 12)	6 (0 24)	6 (0 24)	-	12 (0 47)	165 (6 50)	45 (1 77)	-	9 (0 35)	$\begin{matrix} 0 \\ 22 - 0.013 \\ 0 \\ (0.87 - 0.0005) \end{matrix}$	30 (1 18)	40 (1 57)	9 6 (21 2)
20A□A	200 (7 87)	$\begin{matrix} 0 \\ 114.3 - 0.025 \\ 0 \\ (4.50 - 0.0010) \end{matrix}$	180 (7 09)	3.2 (0 13)	3 (0 12)	0.5 (0 020)	18 (0 71)	230 (9 06)	76 (2 99)	62 (2 44)	13.5 (0 53)	$\begin{matrix} + 0.01 \\ 35 \\ 0 \\ (1.38 + 0.0004) \end{matrix}$	45 (1 77)	76 (2 99)	14 (30 9)
30A□A	200 (7 87)	$\begin{matrix} 0 \\ 114.3 - 0.025 \\ 0 \\ (4.50 - 0.0010) \end{matrix}$	180 (7 09)	3.2 (0 13)	3 (0 12)	0.5 (0 020)	18 (0 71)	230 (9 06)	76 (2 99)	62 (2 44)	13.5 (0 53)	$\begin{matrix} - 0.01 \\ 35 \\ 0 \\ (1.38 + 0.0004) \end{matrix}$	45 (1 77)	76 (2 99)	18 (39 7)
44A□A	200 (7 87)	$\begin{matrix} 0 \\ 114.3 - 0.025 \\ 0 \\ (4.50 - 0.0010) \end{matrix}$	180 (7 09)	3.2 (0 13)	3 (0 12)	0.5 (0 020)	18 (0 71)	230 (9 06)	76 (2 99)	62 (2 44)	13.5 (0 53)	$\begin{matrix} + 0.01 \\ 35 \\ 0 \\ (1.38 - 0.0004) \end{matrix}$	45 (1 77)	76 (2 99)	23 (50 6)
55A□A	200 (7 87)	$\begin{matrix} 0 \\ 114.3 - 0.025 \\ 0 \\ (4.50 - 0.0010) \end{matrix}$	180 (7 09)	3.2 (0 13)	3 (0 12)	0.5 (0 020)	18 (0 71)	230 (9 06)	76 (2 99)	62 (2 44)	13.5 (0 53)	$\begin{matrix} 0 \\ 42 - 0.016 \\ 0 \\ (1.65 - 0.0006) \end{matrix}$	45 (1 77)	110 (4 33)	30 (66 0)
75A□A	200 (7 87)	$\begin{matrix} 0 \\ 114.3 - 0.025 \\ 0 \\ (4.50 - 0.0010) \end{matrix}$	180 (7 09)	3.2 (0 13)	3 (0 12)	0.5 (0 020)	18 (0 71)	230 (9 06)	76 (2 99)	62 (2 44)	13.5 (0 53)	$\begin{matrix} 0 \\ 42 - 0.016 \\ 0 \\ (1.65 - 0.0006) \end{matrix}$	45 (1 77)	110 (4 33)	40 (88 0)
1AA□A	235 (9 25)	$\begin{matrix} 0 \\ 200 - 0.046 \\ 0 \\ (4.50 - 0.0010) \end{matrix}$	220 (8 66)	4 (0 16)	4 (0 16)	-	18 (0 71)	270 (10 6)	62 (2 44)	-	13.5 (0 53)	$\begin{matrix} 0 \\ 42 - 0.016 \\ 0 \\ (1.65 - 0.0006) \end{matrix}$	45 (1 77)	110 (4 33)	57 5 (128)
1EA□A	235 (9 25)	$\begin{matrix} 0 \\ 200 - 0.046 \\ 0 \\ (4.50 - 0.0010) \end{matrix}$	220 (8 66)	4 (0 16)	4 (0 16)	-	20 (0 79)	270 (10 6)	85 (3 35)	-	13.5 (0 53)	$\begin{matrix} + 0.030 \\ 55 + 0.011 \\ 0 \\ (1.65 - 0.0006) \end{matrix}$	65 (2 56)	110 (4 33)	86 (190)

Note The detector is a 17-bit encoder (absolute/incremental)

Cable Specifications for Detector Connectors (17-bit Encoder)

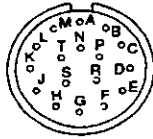

Receptacle MS3102A20-29P
 Applicable plug (purchased by the customer)
 Plug MS3108B20-29S
 Cable clamp MS3057-12A

• With an absolute encoder

A	-	K	-
B	-	L	-
C	DATA+	M	-
D	DATA-	N	-
E	-	P	-
F	-	R	-
G	0V	S	BATT-
H	+5VDC	T	BATT+
J	FG (Frame ground)		-

• With an incremental encoder

A	-	K	-
B	-	L	-
C	DATA+	M	-
D	DATA-	N	-
E	-	P	-
F	-	R	-
G	0V	S	-
H	+5VDC	T	-
J	FG (Frame ground)		-

Cable Specifications for Servomotor Connectors



A	Phase U
B	Phase V
C	Phase W
D	FG (Frame ground)

■ Servomotors with 17-bit Encoders (Absolute/Incremental) and Brakes

- 0.5 to 4.4 kW

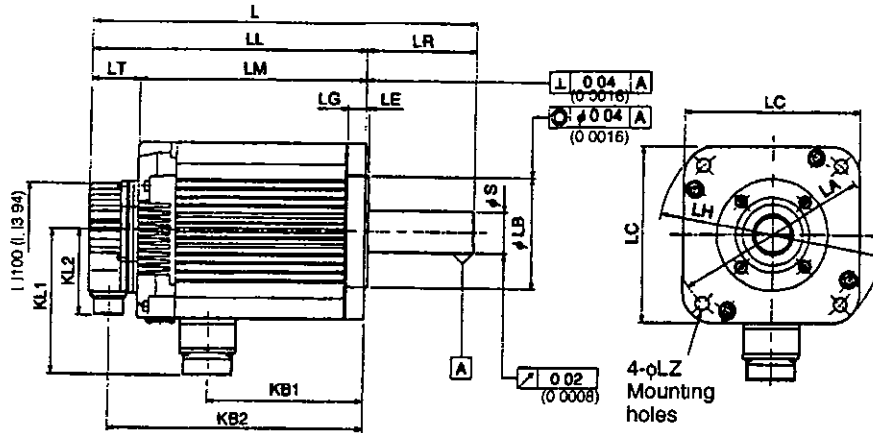

Enlarged View of Shaft End

SGMGH-05A2A□B to 13A2A□B,
SGMGH-05ACA□B to 13ACA□B

SGMGH-20A2A□B to 44A2A□B,
SGMGH-20ACA□B to 44ACA□B

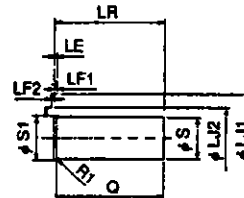
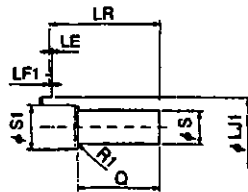

Table 4.27 Servomotors with 17-bit Encoders (Absolute/Incremental) and Brakes (SGMGH-05A□A□B to 44A□A□B, L to KL2) Units mm (in)

Model SGMGH-	L	LL	LM	LR	LT	KB1	KB2	KL1	KL2
05A□A□B	234 (9 21)	176 (6 93)	129 (5 08)	58 (2 28)	47 (1 85)	56 (2 20)	155 (6 10)	120 (4 72)	88 (3 46)
09A□A□B	257 (10 12)	199 (7 83)	152 (5 98)	58 (2 28)	47 (1 85)	79 (3 11)	178 (7 01)	120 (4 72)	88 (3 46)
13A□A□B	281 (11 06)	223 (8 78)	176 (6 93)	58 (2 28)	47 (1 85)	103 (4 06)	202 (7 95)	120 (4 72)	88 (3 46)
20A□A□B	296 (11 65)	217 (8 54)	170 (6 69)	79 (3 11)	47 (1 85)	79 (3 11)	196 (7 72)	146 (5 75)	88 (3 46)
30A□A□B	322 (12 68)	243 (9 57)	196 (7 72)	79 (3 11)	47 (1 85)	105 (4 13)	222 (8 74)	146 (5 75)	88 (3 46)
44A□A□B	356 (14)	277 (10 9)	230 (9 06)	79 (3 11)	47 (1 85)	139 (5 47)	256 (10 1)	146 (5 75)	88 (3 46)

Table 4.28 Servomotors with 17-bit Encoders (Absolute/Incremental) and Brake (SGMGH-05A□A□B to 44A□A□B, LA to Q)

Model SGMGH-	Flange Face Dimensions mm (in)											Shaft-end Dimensions mm (in)			Approx Mass kg (lb)
	LA	LB	LC	LE	LF1	LF2	LG	LH	LJ1	LJ2	LZ	S	S1	Q	
05A□A□B	145 (5 71)	$\begin{matrix} 0 \\ 110 - 0.025 \\ 0 \\ (4.33 - 0.0014) \end{matrix}$	130 (5 12)	6 (0 24)	6 (0 24)	-	12 (0 47)	165 (6 50)	45 (1 77)	-	9 (0 35)	$\begin{matrix} 0 \\ 19 - 0.013 \\ 0 \\ (0.75 - 0.0005) \end{matrix}$	30 (1 18)	40 (1 57)	7.5 (16 5)
09A□A□B	145 (5 71)	$\begin{matrix} 0 \\ 110 - 0.025 \\ 0 \\ (4.33 - 0.0014) \end{matrix}$	130 (5 12)	6 (0 24)	6 (0 24)	-	12 (0 47)	165 (6 50)	45 (1 77)	-	9 (0 35)	$\begin{matrix} 0 \\ 19 - 0.013 \\ 0 \\ (0.75 - 0.0005) \end{matrix}$	30 (1 18)	40 (1 57)	9.6 (21 2)
13A□A□B	145 (5 71)	$\begin{matrix} 0 \\ 110 - 0.035 \\ 0 \\ (4.33 - 0.0014) \end{matrix}$	130 (5 12)	6 (0 24)	6 (0 24)	-	12 (0 47)	165 (6 50)	45 (1 77)	-	9 (0 35)	$\begin{matrix} 0 \\ 22 - 0.013 \\ 0 \\ (0.87 - 0.0005) \end{matrix}$	30 (1 18)	40 (1 57)	12 (26 5)
20A□A□B	200 (7 87)	$\begin{matrix} 0 \\ 114.3 - 0.025 \\ 0 \\ (4.50 - 0.0010) \end{matrix}$	180 (7 09)	3.2 (0 13)	3 (0 12)	0.5 (0 020)	18 (0 71)	230 (9 06)	76 (2 99)	62 (2 44)	13.5 (0 53)	$\begin{matrix} + 0.01 \\ 35 \\ 0 \\ (1.38 + 0.0004) \\ 0 \end{matrix}$	45 (1 77)	76 (2 99)	19 (41 9)
30A□A□B	200 (7 87)	$\begin{matrix} 0 \\ 114.3 - 0.025 \\ 0 \\ (4.50 - 0.0010) \end{matrix}$	180 (7 09)	3.2 (0 13)	3 (0 12)	0.5 (0 020)	18 (0 71)	230 (9 06)	76 (2 99)	62 (2 44)	13.5 (0 53)	$\begin{matrix} + 0.01 \\ 35 \\ 0 \\ (1.38 - 0.0004) \\ 0 \end{matrix}$	45 (1 77)	76 (2 99)	23.5 (51 8)
44A□A□B	200 (7 87)	$\begin{matrix} 0 \\ 114.3 - 0.025 \\ 0 \\ (4.50 - 0.0010) \end{matrix}$	180 (7 09)	3.2 (0 13)	3 (0 12)	0.5 (0 020)	18 (0 71)	230 (9 06)	76 (2 99)	62 (2 44)	13.5 (0 53)	$\begin{matrix} + 0.01 \\ 35 \\ 0 \\ (1.38 + 0.0004) \\ 0 \end{matrix}$	45 (1 77)	76 (2 99)	28.5 (62 7)

Note The detector is a 17-bit encoder (absolute/incremental)

Cable Specifications for Servomotor Connectors

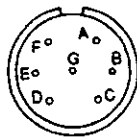

A	Phase U	E	Brake terminal
B	Phase V	F	Brake terminal
C	Phase W	G	-
D	FG (Frame ground)		-

• 55 kW, 75 kW

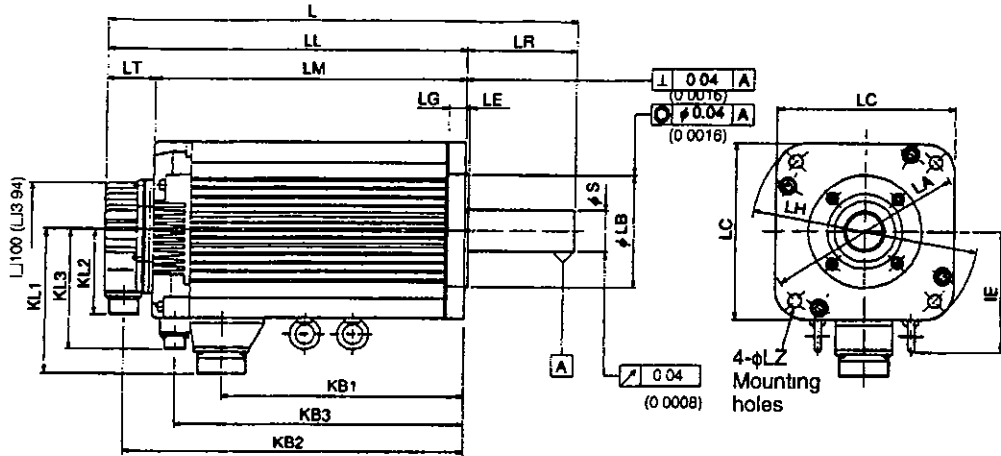

Enlarged View of Shaft End

SGMGH-55A□A□B, -75A□A□B

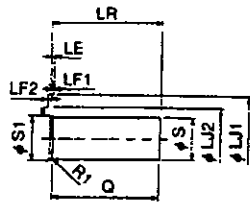

Table 4.29 Servomotors with 17-bit Encoders (Absolute/Incremental) and Brakes (SGMGH-55A□A□B and 75A□A□B, L to KL3) Units mm (in)

Model SGMGH-	L	LL	LM	LR	LT	KB1	KB2	KB3	IE	KL1	KL2	KL3
55A□A□B	424 (16 7)	311 (12 2)	264 (10 4)	113 (4 45)	47 (1 85)	174 (6 85)	290 (11 4)	231 (9 09)	125 (4 92)	150 (5 91)	88 (3 46)	123 (4 84)
75A□A□B	498 (19 6)	385 (15 2)	338 (13 3)	113 (4 45)	47 (1 85)	248 (9 76)	364 (14 3)	305 (12)	125 (4 92)	150 (5 91)	88 (3 46)	123 (4 84)

Table 4.30 Servomotors with 17-bit Encoders (Absolute/Incremental) and Brakes (SGMGH-55A□A□B and 75A□A□B, LA to Q)

Model SGMGH-	Flange Face Dimensions mm (in)											Shaft-end Dimensions mm (in)			Approx Mass kg (lb)
	LA	LB	LC	LE	LF1	LF2	LG	LH	LJ1	LJ2	LZ	S	S1	Q	
55A□A□B	200 (7 87)	0 114.3 - 0.025 (4.50 - 0.0010)	180 (7 09)	32 (0 13)	3 (0 12)	0.5 (0 020)	18 (0 71)	230 (9 06)	76 (2 99)	62 (2 44)	13.5 (0 53)	0 42 - 0.016 (1.65 - 0.0006)	45 (1 77)	110 (4 33)	35 (77 2)
75A□A□B	200 (7 87)	0 114.3 - 0.025 (4.50 - 0.0010)	180 (7 09)	32 (0 13)	3 (0 12)	0.5 (0 020)	18 (0 71)	230 (9 06)	76 (2 99)	62 (2 44)	13.5 (0 53)	0 42 - 0.016 (1.65 - 0.0006)	45 (1 77)	110 (4 33)	45.5 (100)

Note The detector is a 17-bit encoder (absolute/incremental)

Cable Specifications for Servomotor Connectors



A	Brake terminal
B	Brake terminal
C	-



A	Phase U
B	Phase V
C	Phase W
D	FG (Frame ground)

■ Servomotors Without Brakes and With Standard Backlash Gears for 1500 r/min

Type with Foot

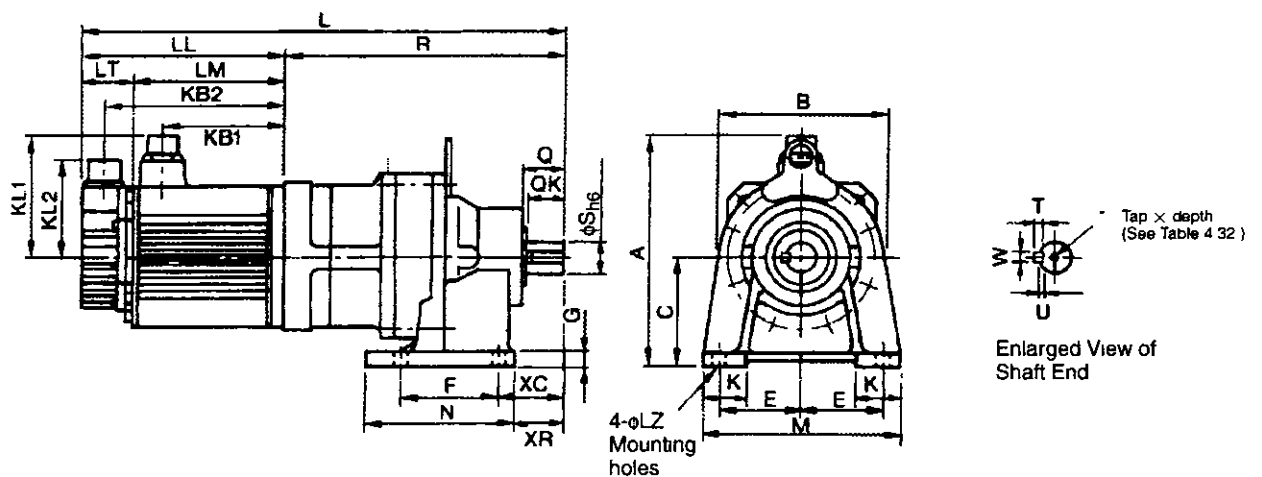

Figure 4.1 Grease Lubricating Type

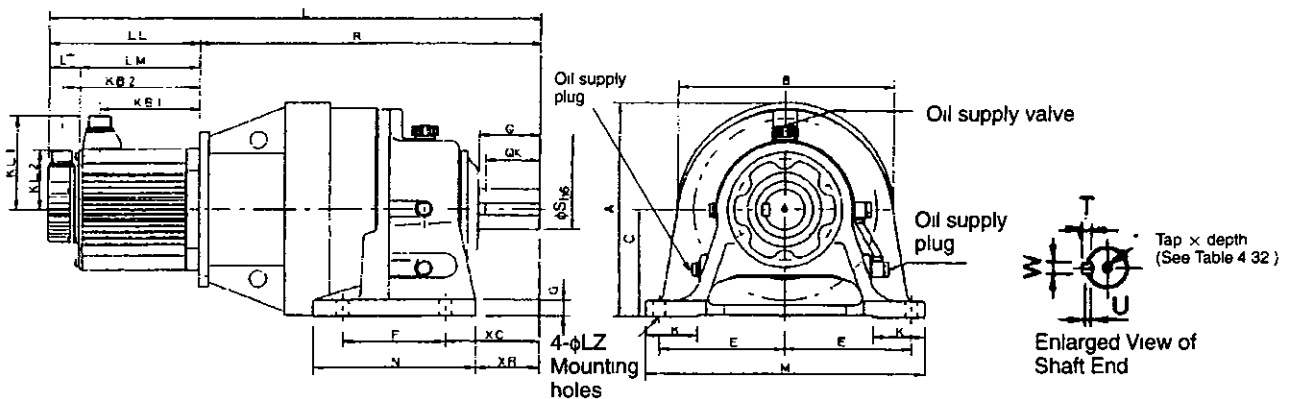

Figure 4.2 Oil Lubricating Type

Table 4.31 Servomotors Without Brakes and With Standard Backlash Gears for 1500 r/min (SGMGH-05A□AS□6 to 75A□AS□6, L to C) Units mm (in)

Model SGMGH-	Gear Type	Gear Ratio	Fig No	L	LL	LM	LT	KB1	KB2	KL1	KL2	R	A	B	C'	Allowable Radial Load on Center of Shaft N (lbf)
05A□ASA6	CNHX-4095	1/6	4 1	380 (14 96)	138 (5 43)	92 (3 62)	46 (1 81)	65 (2 56)	117 (4 61)	109 (4 29)	88 (3 46)	242 (9 53)	209 (8 23)	152 (5 98)	100 (3 94)	2050 (460)
05A□ASB6	CNHX-4095	1/11	4 1	380 (14 96)	138 (5 43)	92 (3 62)	46 (1 81)	65 (2 56)	117 (4 61)	109 (4 29)	88 (3 46)	242 (9 53)	209 (8 23)	152 (5 98)	100 (3 94)	2520 (566)
05A□ASC6	CNHX-4105	1/21	4 1	394 (15 51)	138 (5 43)	92 (3 62)	46 (1 81)	65 (2 56)	117 (4 61)	109 (4 29)	88 (3 46)	256 (10 08)	209 (8 23)	152 (5 98)	100 (3 94)	4940 (1109)
05A□AS76	CNHX-4105	1/29	4 1	394 (15 51)	138 (5 43)	92 (3 62)	46 (1 81)	65 (2 56)	117 (4 61)	109 (4 29)	88 (3 46)	256 (10 08)	209 (8 23)	152 (5 98)	100 (3 94)	5360 (1203)
09A□ASA6	CNHX-4105	1/6	4 1	417 (16 42)	161 (6 34)	115 (4 53)	46 (1 81)	88 (3 46)	140 (5 51)	109 (4 29)	88 (3 46)	256 (10 08)	209 (8 23)	152 (5 98)	100 (3 94)	3240 (727)
09A□ASB6	CNHX-4105	1/11	4 1	417 (16 42)	161 (6 34)	115 (4 53)	46 (1 81)	88 (3 46)	140 (5 51)	109 (4 29)	88 (3 46)	256 (10 08)	209 (8 23)	152 (5 98)	100 (3 94)	3840 (862)
09A□ASC6	CNHX-4115	1/21	4 1	449 (17 68)	161 (6 34)	115 (4 53)	46 (1 81)	88 (3 46)	140 (5 51)	109 (4 29)	88 (3 46)	288 (11 34)	257 (10 12)	204 (8 03)	120 (4 72)	6190 (1390)
09A□AS76	CNHX-4115	1/29	4 1	449 (17 68)	161 (6 34)	115 (4 53)	46 (1 81)	88 (3 46)	140 (5 51)	109 (4 29)	88 (3 46)	288 (11 34)	257 (10 12)	204 (8 03)	120 (4 72)	6870 (1542)
13A□ASA6	CNHX-4105	1/6	4 1	441 (17 36)	185 (7 28)	139 (5 47)	46 (1 81)	112 (4 41)	164 (6 46)	109 (4 29)	88 (3 46)	256 (10 08)	209 (8 23)	152 (5 98)	100 (3 94)	3240 (727)
13A□ASB6	CNHX-4115	1/11	4 1	473 (18 62)	185 (7 28)	139 (5 47)	46 (1 81)	112 (4 41)	164 (6 46)	109 (4 29)	88 (3 46)	288 (11 34)	257 (10 12)	204 (8 03)	120 (4 72)	4970 (1116)
13A□ASC6	CNHX-4115	1/21	4 1	473 (18 62)	185 (7 28)	139 (5 47)	46 (1 81)	112 (4 41)	164 (6 46)	109 (4 29)	88 (3 46)	288 (11 34)	257 (10 12)	204 (8 03)	120 (4 72)	6190 (1390)
13A□AS76	CHHX-4135	1/29	4 1	532 (20 94)	185 (7 28)	139 (5 47)	46 (1 81)	112 (4 41)	164 (6 46)	109 (4 29)	88 (3 46)	347 (13 66)	300 (11 81)	246 (9 69)	150 (5 91)	9900 (2222)
20A□ASA6	CNHX-4115	1/6	4 1	477 (18 78)	166 (6 54)	119 (4 69)	47 (1 85)	89 (3 50)	145 (5 71)	140 (5 51)	88 (3 46)	311 (12 24)	260 (10 24)	204 (8 03)	120 (4 72)	4050 (909)
20A□ASB6	CNHX-4115	1/11	4 1	477 (18 78)	166 (6 54)	119 (4 69)	47 (1 85)	89 (3 50)	145 (5 71)	140 (5 51)	88 (3 46)	311 (12 24)	260 (10 24)	204 (8 03)	120 (4 72)	4970 (1116)
20A□ASC6	CHHX-4130	1/21	4 1	536 (21 10)	166 (6 54)	119 (4 69)	47 (1 85)	89 (3 50)	145 (5 71)	140 (5 51)	88 (3 46)	370 (14 57)	300 (11 81)	246 (9 69)	150 (5 91)	8940 (2007)
20A□AS76	CHHX-4135	1/29	4 1	536 (21 10)	166 (6 54)	119 (4 69)	47 (1 85)	89 (3 50)	145 (5 71)	140 (5 51)	88 (3 46)	370 (14 57)	300 (11 81)	246 (9 69)	150 (5 91)	9900 (2222)
30A□ASA6	CNHX-4115	1/6	4 1	503 (19 80)	192 (7 56)	145 (5 71)	47 (1 85)	115 (4 53)	171 (6 73)	140 (5 51)	88 (3 46)	311 (12 24)	260 (10 24)	204 (8 03)	120 (4 72)	4050 (909)
30A□ASB6	CNHX-4115	1/11	4 1	503 (19 80)	192 (7 56)	145 (5 71)	47 (1 85)	115 (4 53)	171 (6 73)	140 (5 51)	88 (3 46)	311 (12 24)	260 (10 24)	204 (8 03)	120 (4 72)	4970 (1116)
30A□ASC6	CHHX-4145	1/21	4 1	582 (22 91)	192 (7 56)	145 (5 71)	47 (1 85)	115 (4 53)	171 (6 73)	140 (5 51)	88 (3 46)	390 (15 35)	300 (11 81)	246 (9 69)	150 (5 91)	11590 (2602)
30A□AS76	CHJH-4160	1/29	4 2	687 (27 05)	192 (7 56)	145 (5 71)	47 (1 85)	115 (4 53)	171 (6 73)	140 (5 51)	88 (3 46)	495 (19 49)	319 (12 56)	318 (12 52)	160 (6 30)	16290 (3657)
44A□ASA6	CHHX-4130	1/6	4 1	596 (23 5)	226 (8 9)	179 (7 05)	47 (1 85)	149 (5 87)	205 (8 07)	140 (5 51)	88 (3 46)	370 (14 6)	300 (11 8)	246 (9 69)	150 (5 91)	5870 (1318)
44A□ASB6	CHHX-4135	1/11	4 1	596 (23 5)	226 (8 9)	179 (7 05)	47 (1 85)	149 (5 87)	205 (8 07)	140 (5 51)	88 (3 46)	370 (14 6)	300 (11 8)	246 (9 69)	150 (5 91)	7190 (1614)
44A□ASC6	CHJH-4160	1/21	4 2	721 (28 4)	226 (8 9)	179 (7 05)	47 (1 85)	149 (5 87)	205 (8 07)	140 (5 51)	88 (3 46)	495 (19 5)	319 (12 6)	318 (12 5)	160 (6 3)	14640 (3287)
44A□AS76	CHJH-4170	1/29	4 2	785 (30 9)	226 (8 9)	179 (7 05)	47 (1 85)	149 (5 87)	205 (8 07)	140 (5 51)	88 (3 46)	559 (22)	382 (15)	363 (14 3)	200 (7 87)	19020 (4270)
55A□ASA6	CHHX-4135	1/6	4 1	664 (26 1)	260 (10 2)	213 (8 39)	47 (1 85)	174 (6 85)	239 (9 41)	150 (5 91)	88 (3 46)	404 (15 9)	300 (11 8)	246 (9 69)	150 (5 91)	5870 (1318)
55A□ASB6	CHHX-4145	1/11	4 1	684 (26 9)	260 (10 2)	213 (8 39)	47 (1 85)	174 (6 85)	239 (9 41)	150 (5 91)	88 (3 46)	424 (16 7)	300 (11 8)	246 (9 69)	150 (5 91)	9500 (2133)
55A□ASC6	CHJH-4170	1/21	4 2	853 (33 6)	260 (10 2)	213 (8 39)	47 (1 85)	174 (6 85)	239 (9 41)	150 (5 91)	88 (3 46)	593 (23 3)	382 (15)	363 (14 3)	200 (7 87)	17180 (3857)
55A□AS76	CHJH-4175	1/29	4 2	853 (33 6)	260 (10 2)	213 (8 39)	47 (1 85)	174 (6 85)	239 (9 41)	150 (5 91)	88 (3 46)	593 (23 3)	382 (15)	363 (14 3)	200 (7 87)	19020 (4270)
75A□ASB6	CHJH-4160	1/11	4 2	863 (34)	334 (13 1)	287 (11 3)	47 (1 85)	248 (9 76)	313 (12 3)	150 (5 91)	88 (3 46)	529 (20 8)	319 (12 6)	318 (12 5)	160 (6 3)	11740 (2636)
75A□ASC6	CHJH-4175	1/21	4 2	927 (36 5)	334 (13 1)	287 (11 3)	47 (1 85)	248 (9 76)	313 (12 3)	150 (5 91)	88 (3 46)	593 (23 3)	381 (15)	363 (14 3)	200 (7 87)	17180 (3857)
75A□AS76	CHJH-4180	1/29	4 2	977 (38 5)	334 (13 1)	287 (11 3)	47 (1 85)	248 (9 76)	313 (12 3)	150 (5 91)	88 (3 46)	643 (25 3)	417 (16 4)	392 (15 4)	220 (8 66)	25600 (1290)

Servodrive Dimensional Drawings

4 1 3 SGMGH Servomotors (1500 r/min)

* The tolerances for all models are $\begin{matrix} 0 \\ -0.5 \end{matrix}$

Table 4 32 Servomotors Without Brakes and With Standard Backlash Gears for 1500 r/min (SGMGH-05A□AS□6 to 75A□AS□6, E to W)

Model SGMGH-	Dimensions with Feet mm (in)									Shaft-end Dimensions mm (in)						Approx Mass kg (lb)	
	E	F	G	K	M	N	XR	XC	Z	Q	QK	S	T	U	W		*Tap × Depth
05A□ASA6	75 (2.95)	90 (3.54)	12 (0.47)	40 (1.57)	180 (7.09)	130 (5.12)	45 (1.77)	60 (2.36)	11 (0.43)	35 (1.38)	32 (1.26)	28 (1.10)	7 (0.28)	4 (0.16)	8 (0.31)	M8 × 19 (0.75)	20.5 (45.2)
05A□ASB6	75 (2.95)	90 (3.54)	12 (0.47)	40 (1.57)	180 (7.09)	130 (5.12)	45 (1.77)	60 (2.36)	11 (0.43)	35 (1.38)	32 (1.26)	28 (1.10)	7 (0.28)	4 (0.16)	8 (0.31)	M8 × 19 (0.75)	20.5 (45.2)
05A□ASC6	75 (2.95)	90 (3.54)	12 (0.47)	40 (1.57)	180 (7.09)	135 (5.31)	45 (1.77)	60 (2.36)	11 (0.43)	35 (1.38)	32 (1.26)	28 (1.10)	7 (0.28)	4 (0.16)	8 (0.31)	M8 × 19 (0.75)	22.5 (49.6)
05A□AS76	75 (2.95)	90 (3.54)	12 (0.47)	40 (1.57)	180 (7.09)	135 (5.31)	45 (1.77)	60 (2.36)	11 (0.43)	35 (1.38)	32 (1.26)	28 (1.10)	7 (0.28)	4 (0.16)	8 (0.31)	M8 × 19 (0.75)	22.5 (49.6)
09A□ASA6	75 (2.95)	90 (3.54)	12 (0.47)	40 (1.57)	180 (7.09)	135 (5.31)	45 (1.77)	60 (2.36)	11 (0.43)	35 (1.38)	32 (1.26)	28 (1.10)	7 (0.28)	4 (0.16)	8 (0.31)	M8 × 19 (0.75)	24.6 (54.2)
09A□ASB6	75 (2.95)	90 (3.54)	12 (0.47)	40 (1.57)	180 (7.09)	135 (5.31)	45 (1.77)	60 (2.36)	11 (0.43)	35 (1.38)	32 (1.26)	28 (1.10)	7 (0.28)	4 (0.16)	8 (0.31)	M8 × 19 (0.75)	24.6 (54.2)
09A□ASC6	95 (3.74)	115 (4.53)	15 (0.59)	55 (2.17)	230 (9.06)	155 (6.10)	62 (2.44)	82 (3.23)	14 (0.55)	55 (2.17)	50 (1.97)	38 (1.50)	8 (0.31)	5 (0.20)	10 (0.39)	M10 × 22 (0.87)	34.6 (76.3)
09A□AS76	95 (3.74)	115 (4.53)	15 (0.59)	55 (2.17)	230 (9.06)	155 (6.10)	62 (2.44)	82 (3.23)	14 (0.55)	55 (2.17)	50 (1.97)	38 (1.50)	8 (0.31)	5 (0.20)	10 (0.39)	M10 × 22 (0.87)	34.6 (76.3)
13A□ASA6	75 (2.95)	90 (3.54)	12 (0.47)	40 (1.57)	180 (7.09)	135 (5.31)	45 (1.77)	60 (2.36)	11 (0.43)	35 (1.38)	32 (1.26)	28 (1.10)	7 (0.28)	4 (0.16)	8 (0.31)	M8 × 19 (0.75)	26.6 (58.6)
13A□ASB6	95 (3.74)	115 (4.53)	15 (0.59)	55 (2.17)	230 (9.06)	155 (6.10)	62 (2.44)	82 (3.23)	14 (0.55)	55 (2.17)	50 (1.97)	38 (1.50)	8 (0.31)	5 (0.20)	10 (0.39)	M10 × 22 (0.87)	36.6 (80.7)
13A□ASC6	95 (3.74)	115 (4.53)	15 (0.59)	55 (2.17)	230 (9.06)	155 (6.10)	62 (2.44)	82 (3.23)	14 (0.55)	55 (2.17)	50 (1.97)	38 (1.50)	8 (0.31)	5 (0.20)	10 (0.39)	M10 × 22 (0.87)	36.6 (80.7)
13A□AS76	145 (5.71)	145 (5.71)	22 (0.87)	65 (2.56)	330 (12.99)	195 (7.68)	75 (2.95)	100 (3.94)	18 (0.71)	70 (2.76)	56 (2.20)	50 (1.97)	9 (0.35)	5.5 (0.22)	14 (0.55)	M10 × 18 (0.71)	57.6 (127)
20A□ASA6	95 (3.74)	115 (4.53)	15 (0.59)	55 (2.17)	230 (9.06)	155 (6.10)	62 (2.44)	82 (3.23)	14 (0.55)	55 (2.17)	50 (1.97)	38 (1.50)	8 (0.31)	5 (0.20)	10 (0.39)	M10 × 22 (0.87)	43 (94.8)
20A□ASB6	95 (3.74)	115 (4.53)	15 (0.59)	55 (2.17)	230 (9.06)	155 (6.10)	62 (2.44)	82 (3.23)	14 (0.55)	55 (2.17)	50 (1.97)	38 (1.50)	8 (0.31)	5 (0.20)	10 (0.39)	M10 × 22 (0.87)	43 (94.8)
20A□ASC6	145 (5.71)	145 (5.71)	22 (0.87)	65 (2.56)	330 (12.99)	195 (7.68)	75 (2.95)	100 (3.94)	18 (0.71)	70 (2.76)	56 (2.20)	50 (1.97)	9 (0.35)	5.5 (0.22)	14 (0.55)	M10 × 18 (0.71)	67 (148)
20A□AS76	145 (5.71)	145 (5.71)	22 (0.87)	65 (2.56)	330 (12.99)	195 (7.68)	75 (2.95)	100 (3.94)	18 (0.71)	70 (2.76)	56 (2.20)	50 (1.97)	9 (0.35)	5.5 (0.22)	14 (0.55)	M10 × 18 (0.71)	67 (148)
30A□ASA6	95 (3.74)	115 (4.53)	15 (0.59)	55 (2.17)	230 (9.06)	155 (6.10)	62 (2.44)	82 (3.23)	14 (0.55)	55 (2.17)	50 (1.97)	38 (1.50)	8 (0.31)	5 (0.20)	10 (0.39)	M10 × 22 (0.87)	47 (104)
30A□ASB6	95 (3.74)	115 (4.53)	15 (0.59)	55 (2.17)	230 (9.06)	155 (6.10)	62 (2.44)	82 (3.23)	14 (0.55)	55 (2.17)	50 (1.97)	38 (1.50)	8 (0.31)	5 (0.20)	10 (0.39)	M10 × 22 (0.87)	47 (104)
30A□ASC6	145 (5.71)	145 (5.71)	22 (0.87)	65 (2.56)	330 (12.99)	195 (7.68)	75 (2.95)	100 (3.94)	18 (0.71)	70 (2.76)	56 (2.20)	50 (1.97)	9 (0.35)	5.5 (0.22)	14 (0.55)	M10 × 18 (0.71)	72 (159)
30A□AS76	185 (7.28)	150 (5.91)	25 (0.98)	75 (2.95)	410 (16.14)	235 (9.37)	95 (3.74)	139 (5.47)	18 (0.71)	90 (3.54)	80 (3.15)	60 (2.36)	11 (0.43)	7 (0.28)	18 (0.71)	M10 × 18 (0.71)	126 (278)
44A□ASA6	145 (5.71)	145 (5.71)	22 (0.87)	65 (2.56)	330 (13)	195 (7.68)	75 (2.95)	100 (3.94)	18 (0.71)	70 (2.76)	56 (2.2)	50 (1.97)	9 (0.35)	5.5 (0.22)	14 (0.55)	M10 × 18 (0.71)	76 (168)
44A□ASB6	145 (5.71)	145 (5.71)	22 (0.87)	65 (2.56)	330 (13)	195 (7.68)	75 (2.95)	100 (3.94)	18 (0.71)	70 (2.76)	56 (2.2)	50 (1.97)	9 (0.35)	5.5 (0.22)	14 (0.55)	M10 × 18 (0.71)	76 (168)
44A□ASC6	185 (7.28)	150 (5.91)	25 (0.98)	75 (2.95)	410 (16.1)	235 (9.37)	95 (3.74)	139 (5.47)	18 (0.71)	90 (3.54)	80 (3.15)	60 (2.36)	11 (0.43)	7 (0.28)	18 (0.71)	M10 × 18 (0.71)	131 (289)
44A□AS76	190 (7.48)	275 (10.8)	30 (1.18)	80 (3.15)	430 (16.9)	335 (13.2)	95 (3.74)	125 (4.92)	22 (0.87)	90 (3.54)	80 (3.15)	70 (2.76)	12 (0.47)	7.5 (0.3)	20 (0.79)	M12 × 24 (0.94)	176 (388)
55A□ASA6	145 (5.71)	145 (5.71)	22 (0.87)	65 (2.56)	330 (13)	195 (7.68)	75 (2.95)	100 (3.94)	18 (0.71)	70 (2.76)	56 (2.2)	50 (1.97)	9 (0.35)	5.5 (0.22)	14 (0.55)	M10 × 18 (0.71)	88 (194)
55A□ASB6	145 (5.71)	145 (5.71)	22 (0.87)	65 (2.56)	330 (13)	195 (7.68)	75 (2.95)	100 (3.94)	18 (0.71)	70 (2.76)	56 (2.2)	50 (1.97)	9 (0.35)	5.5 (0.22)	14 (0.55)	M10 × 18 (0.71)	89 (196)
55A□ASC6	190 (7.48)	275 (10.8)	30 (1.18)	80 (3.15)	430 (16.9)	335 (13.2)	95 (3.74)	125 (4.92)	22 (0.87)	90 (3.54)	80 (3.15)	70 (2.76)	12 (0.47)	7.5 (0.3)	20 (0.79)	M12 × 24 (0.94)	191 (421)
55A□AS76	190 (7.48)	275 (10.8)	30 (1.18)	80 (3.15)	430 (16.9)	335 (13.2)	95 (3.74)	125 (4.92)	22 (0.87)	90 (3.54)	80 (3.15)	70 (2.76)	12 (0.47)	7.5 (0.3)	20 (0.79)	M12 × 24 (0.94)	191 (421)
75A□ASB6	185 (7.28)	150 (5.91)	25 (0.98)	75 (2.95)	410 (16.1)	235 (9.37)	95 (3.74)	139 (5.47)	18 (0.71)	90 (3.54)	80 (3.15)	60 (2.36)	11 (0.43)	7 (0.28)	18 (0.71)	M10 × 18 (0.71)	155 (342)

Model SGMGH-	Dimensions with Feet mm (in)									Shaft-end Dimensions mm (in)							Approx Mass kg (lb)
	E	F	G	K	M	N	XR	XC	Z	Q	QK	S	T	U	W	*Tap x Depth	
75A□ASC6	190 (7.48)	275 (10.8)	30 (1.18)	80 (3.15)	430 (16.9)	335 (13.2)	95 (3.74)	125 (4.92)	22 (0.87)	90 (3.54)	80 (3.15)	70 (2.76)	12 (0.47)	7.5 (0.3)	20 (0.79)	M12 x 24 (0.94)	201 (443)
75A□AS76	210 (8.27)	320 (12.6)	30 (1.18)	85 (3.35)	470 (18.5)	380 (15)	115 (4.53)	145 (5.71)	22 (0.87)	110 (4.33)	100 (3.94)	80 (3.15)	14 (0.55)	9 (0.35)	22 (0.87)	M12 x 24 (0.94)	245 (540)

• Dimensional Tolerances

Model SGMGH-	Shaft-end Dimensions mm (in)
	S
05A□ASA6	28 ⁰ / _{-0.013} (1 11 - ⁰ / _{0.0005})
05A□ASB6	28 ⁰ / _{-0.013} (1 11 - ⁰ / _{0.0005})
05A□ASC6	28 ⁰ / _{-0.013} (1 11 - ⁰ / _{0.0005})
05A□AS76	28 ⁰ / _{-0.013} (1 11 - ⁰ / _{0.0005})
09A□ASA6	28 ⁰ / _{-0.013} (1 11 - ⁰ / _{0.0005})
09A□ASB6	28 ⁰ / _{-0.013} (1 11 - ⁰ / _{0.0005})
09A□ASC6	38 ⁰ / _{-0.016} (1 51 - ⁰ / _{0.0006})
09A□AS76	38 ⁰ / _{-0.016} (1 51 - ⁰ / _{0.0006})
13A□ASA6	28 ⁰ / _{-0.013} (1 11 - ⁰ / _{0.0005})
13A□ASB6	38 ⁰ / _{-0.016} (1 51 - ⁰ / _{0.0006})
13A□ASC6	38 ⁰ / _{-0.016} (1 51 - ⁰ / _{0.0006})
13A□AS76	50 ⁰ / _{-0.016} (1 98 - ⁰ / _{0.0006})
20A□ASA6	38 ⁰ / _{-0.016} (1 51 - ⁰ / _{0.0006})
20A□ASB6	38 ⁰ / _{-0.016} (1 51 - ⁰ / _{0.0006})
20A□ASC6	50 ⁰ / _{-0.016} (1 98 - ⁰ / _{0.0006})
20A□AS76	50 ⁰ / _{-0.016} (1 98 - ⁰ / _{0.0006})
30A□ASA6	38 ⁰ / _{-0.016} (1 51 - ⁰ / _{0.0006})
30A□ASB6	38 ⁰ / _{-0.016} (1 51 - ⁰ / _{0.0006})
30A□ASC6	50 ⁰ / _{-0.016} (1 98 - ⁰ / _{0.0006})
30A□AS76	60 ⁰ / _{-0.019} (2 38 - ⁰ / _{0.0008})
44A□ASA6	50 ⁰ / _{-0.016} (1 98 - ⁰ / _{0.0006})
44A□ASB6	50 ⁰ / _{-0.016} (1 98 - ⁰ / _{0.0006})



Servodrive Dimensional Drawings

4 1 3 SGMGH Servomotors (1500 r/min)

Model SGMGH-	Shaft-end Dimensions mm (in)
	S
44A□ASC6	$60 \begin{smallmatrix} 0 \\ - 0.019 \end{smallmatrix} \left(2.38 \begin{smallmatrix} 0 \\ - 0.0008 \end{smallmatrix} \right)$
44A□AS76	$70 \begin{smallmatrix} 0 \\ - 0.019 \end{smallmatrix} \left(2.78 \begin{smallmatrix} 0 \\ - 0.0008 \end{smallmatrix} \right)$
55A□ASA6	$50 \begin{smallmatrix} 0 \\ - 0.016 \end{smallmatrix} \left(1.98 \begin{smallmatrix} 0 \\ - 0.0006 \end{smallmatrix} \right)$
55A□ASB6	$50 \begin{smallmatrix} 0 \\ - 0.016 \end{smallmatrix} \left(1.98 \begin{smallmatrix} 0 \\ - 0.0006 \end{smallmatrix} \right)$
55A□ASC6	$70 \begin{smallmatrix} 0 \\ - 0.019 \end{smallmatrix} \left(2.78 \begin{smallmatrix} 0 \\ - 0.0008 \end{smallmatrix} \right)$
55A□AS76	$70 \begin{smallmatrix} 0 \\ - 0.019 \end{smallmatrix} \left(2.78 \begin{smallmatrix} 0 \\ - 0.0008 \end{smallmatrix} \right)$
75A□ASB6	$60 \begin{smallmatrix} 0 \\ - 0.019 \end{smallmatrix} \left(2.38 \begin{smallmatrix} 0 \\ - 0.0008 \end{smallmatrix} \right)$
75A□ASC6	$70 \begin{smallmatrix} 0 \\ - 0.019 \end{smallmatrix} \left(2.78 \begin{smallmatrix} 0 \\ - 0.0008 \end{smallmatrix} \right)$
75A□AS76	$80 \begin{smallmatrix} 0 \\ - 0.022 \end{smallmatrix} \left(3.1 \begin{smallmatrix} 0 \\ - 0.0007 \end{smallmatrix} \right)$

Flange Type

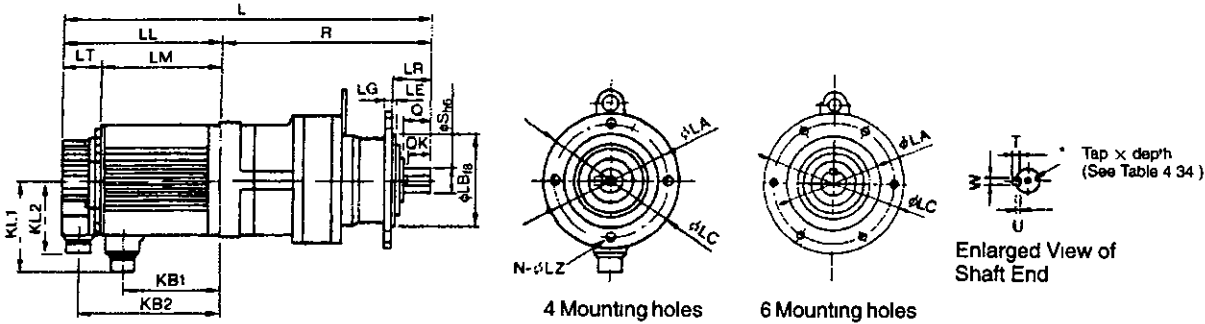

Figure 4.3 Grease Lubricating Type

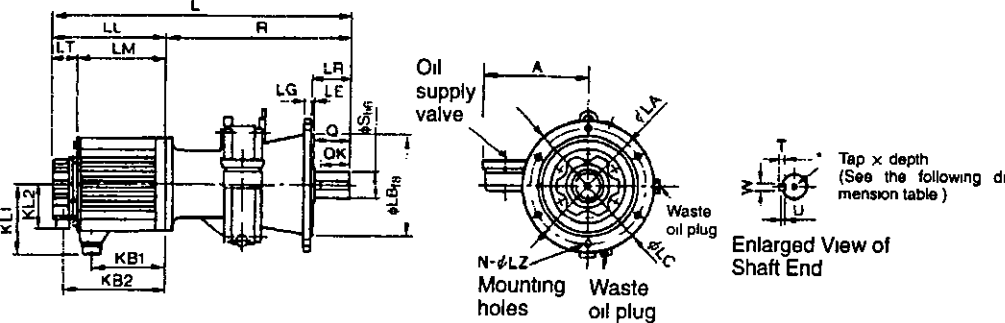

Figure 4.4 Smaller Oil Lubricating Type

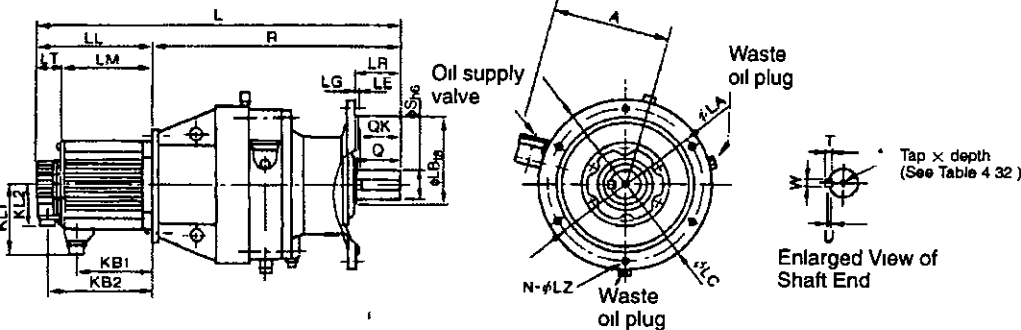

Figure 4.5 Larger Oil Lubricating Type



Servodrive Dimensional Drawings

4 1 3 SGMGH Servomotors (1500 r/min)

Table 4 33 Servomotors Without Brakes and With Standard Backlash Gears for 1500 r/min (SGMGH-05A□AT□6 to 75A□AT□6, L to A) Units: mm (in)

Model SGMGH-	Gear Type	Gear Ratio	Fig No	L	LL	LM	LT	KB1	KB2	KL1	KL2	R	A	Allowable Radial Load on Center of Shaft N (lbf)
05A□ATA6	CNVX-4095	1/6	4 3	380 (14 96)	138 (5 43)	92 (3 62)	46 (1 81)	65 (2 56)	117 (4 61)	109 (4 29)	88 (3 46)	242 (9 53)	-	2050 (460)
05A□ATB6	CNVX-4095	1/11	4 3	380 (14 96)	138 (5 43)	92 (3 62)	46 (1 81)	65 (2 56)	117 (4 61)	109 (4 29)	88 (3 46)	242 (9 53)	-	2520 (566)
05A□ATC6	CNVX-4105	1/21	4 3	394 (15 51)	138 (5 43)	92 (3 62)	46 (1 81)	65 (2 56)	117 (4 61)	109 (4 29)	88 (3 46)	256 (10 08)	-	4940 (1109)
05A□AT76	CNVX-4105	1/29	4 3	394 (15 51)	138 (5 43)	92 (3 62)	46 (1 81)	65 (2 56)	117 (4 61)	109 (4 29)	88 (3 46)	256 (10 08)	-	5360 (1203)
09A□ATA6	CNVX-4105	1/6	4 3	417 (16 42)	161 (6 34)	115 (4 53)	46 (1 81)	88 (3 46)	140 (5 51)	109 (4 29)	88 (3 46)	256 (10 08)	-	3240 (727)
09A□ATB6	CNVX-4105	1/11	4 3	417 (16 42)	161 (6 34)	115 (4 53)	46 (1 81)	88 (3 46)	140 (5 51)	109 (4 29)	88 (3 46)	256 (10 08)	-	3840 (862)
09A□ATC6	CNVX-4115	1/21	4 3	449 (17 68)	161 (6 34)	115 (4 53)	46 (1 81)	88 (3 46)	140 (5 51)	109 (4 29)	88 (3 46)	288 (11 34)	-	6190 (1390)
09A□AT76	CNVX-4115	1/29	4 3	449 (17 68)	161 (6 34)	115 (4 53)	46 (1 81)	88 (3 46)	140 (5 51)	109 (4 29)	88 (3 46)	288 (11 34)	-	6870 (1542)
13A□ATA6	CNVX-4105	1/6	4 3	441 (17 36)	185 (7 28)	139 (5 47)	46 (1 81)	112 (4 41)	164 (6 46)	109 (4 29)	88 (3 46)	256 (10 08)	-	3240 (727)
13A□ATB6	CNVX-4115	1/11	4 3	473 (18 62)	185 (7 28)	139 (5 47)	46 (1 81)	112 (4 41)	164 (6 46)	109 (4 29)	88 (3 46)	288 (11 34)	-	4970 (1116)
13A□ATC6	CNVX-4115	1/21	4 3	473 (18 62)	185 (7 28)	139 (5 47)	46 (1 81)	112 (4 41)	164 (6 46)	109 (4 29)	88 (3 46)	288 (11 34)	-	6190 (1390)
13A□AT76	CHVX-4135	1/29	4 4	532 (20 94)	185 (7 28)	139 (5 47)	46 (1 81)	112 (4 41)	164 (6 46)	109 (4 29)	88 (3 46)	347 (13 66)	209 (8 23)	9900 (2222)
20A□ATA6	CNVX-4115	1/6	4 3	477 (18 78)	166 (6 54)	119 (4 69)	47 (1 85)	89 (3 50)	145 (5 71)	140 (5 51)	88 (3 46)	311 (12 24)	-	4050 (909)
20A□ATB6	CNVX-4115	1/11	4 3	477 (18 78)	166 (6 54)	119 (4 69)	47 (1 85)	89 (3 50)	145 (5 71)	140 (5 51)	88 (3 46)	311 (12 24)	-	4970 (1116)
20A□ATC6	CHVX-4130	1/21	4 4	536 (21 10)	166 (6 54)	119 (4 69)	47 (1 85)	89 (3 50)	145 (5 71)	140 (5 51)	88 (3 46)	370 (14 57)	209 (8 23)	8940 (2007)
20A□AT76	CHVX-4135	1/29	4 4	536 (21 10)	166 (6 54)	119 (4 69)	47 (1 85)	89 (3 50)	145 (5 71)	140 (5 51)	88 (3 46)	370 (14 57)	209 (8 23)	9900 (2222)
30A□ATA6	CNVX-4115	1/6	4 3	503 (19 80)	192 (7 56)	145 (5 71)	47 (1 85)	115 (4 53)	171 (6 73)	140 (5 51)	88 (3 46)	311 (12 24)	-	4050 (909)
30A□ATB6	CNVX-4115	1/11	4 3	503 (19 80)	192 (7 56)	145 (5 71)	47 (1 85)	115 (4 53)	171 (6 73)	140 (5 51)	88 (3 46)	311 (12 24)	-	4970 (1116)
30A□ATC6	CHVX-4145	1/21	4 3	582 (22 91)	192 (7 56)	145 (5 71)	47 (1 85)	115 (4 53)	171 (6 73)	140 (5 51)	88 (3 46)	390 (15 35)	209 (8 23)	11590 (2602)
30A□AT76	CHVJ-4160	1/29	4 5	687 (27 05)	192 (7 56)	145 (5 71)	47 (1 85)	115 (4 53)	171 (6 73)	140 (5 51)	88 (3 46)	495 (19 49)	228 (8 98)	16290 (3657)
44A□ATA6	CHVX-4130	1/6	4 4	596 (23 5)	226 (8 9)	179 (7 05)	47 (1 85)	149 (5 87)	205 (8 07)	140 (5 51)	88 (3 46)	370 (14 6)	209 (8 23)	5870 (1318)
44A□ATB6	CHVX-4135	1/11	4 4	596 (23 5)	226 (8 9)	179 (7 05)	47 (1 85)	149 (5 87)	205 (8 07)	140 (5 51)	88 (3 46)	370 (14 6)	209 (8 23)	7190 (1614)
44A□ATC6	CHVJ-4160	1/21	4 5	721 (28 4)	226 (8 9)	179 (7 05)	47 (1 85)	149 (5 87)	205 (8 07)	140 (5 51)	88 (3 46)	495 (19 5)	228 (8 98)	14640 (3287)
44A□AT76	CHVJ-4170	1/29	4 5	785 (30 9)	226 (8 9)	179 (7 05)	47 (1 85)	149 (5 87)	205 (8 07)	140 (5 51)	88 (3 46)	559 (22)	243 (9 57)	19020 (4270)
55A□ATA6	CHVX-4135	1/6	4 4	664 (26 1)	260 (10 2)	213 (8 39)	47 (1 85)	174 (6 85)	239 (9 41)	150 (5 91)	88 (3 46)	404 (15 9)	209 (8 23)	5870 (1318)
55A□ATB6	CHVX-4145	1/11	4 4	684 (26 9)	260 (10 2)	213 (8 39)	47 (1 85)	174 (6 85)	239 (9 41)	150 (5 91)	88 (3 46)	424 (16 7)	209 (8 23)	9500 (2133)

Model SGMGH-	Gear Type	Gear Ratio	Fig. No	L	LL	LM	LT	KB1	KB2	KL1	KL2	R	A	Allowable Radial Load on Center of Shaft N (lbf)
55A□ATC6	CHVJ-4170	1/21	4 5	853 (33 6)	260 (10 2)	213 (8 39)	47 (1 85)	174 (6 85)	239 (9 41)	150 (5 91)	88 (3 46)	593 (23 3)	243 (9 57)	17180 (3857)
55A□AT76	CHVJ-4175	1/29	4 5	853 (33 6)	260 (10 2)	213 (8 39)	47 (1 85)	174 (6 85)	239 (9 41)	150 (5 91)	88 (3 46)	593 (23 3)	243 (9 57)	19020 (4270)
75A□ATB6	CHVJ-4160	1/11	4 5	863 (34)	334 (13 1)	287 (11 3)	47 (1 85)	248 (9 76)	313 (12 3)	150 (5 91)	88 (3 46)	529 (20 8)	228 (8 98)	11740 (2636)
75A□ATC6	CHVJ-4175	1/21	4 5	927 (36 5)	334 (13 1)	287 (11 3)	47 (1 85)	248 (9 76)	313 (12 3)	150 (5 91)	88 (3 46)	593 (23 3)	243 (9 57)	17180 (3857)
75A□AT76	CHVJ-4180	1/29	4 5	977 (38 5)	334 (13 1)	287 (11 3)	47 (1 85)	248 (9 76)	313 (12 3)	150 (5 91)	88 (3 46)	643 (25 3)	258 (10 2)	25600 (1290)

Table 4.34 Servomotors Without Brakes and With Standard Backlash Gears for 1500 r/min (SGMGH-05A□AT□6 to 75A□AT□6, LA to W)

Model SGMGH-	Flange Face Dimensions mm (in)								Shaft-end Dimensions mm (in)							Approx Mass kg (lb)
	LA	LB	LC	LE	LG	LR	N	LZ	Q	QK	S	T	U	W	Tap × Depth	
05A□ATA6	134 (5 28)	110 (4 33)	160 (6 30)	3 (0 12)	9 (0 35)	48 (1 89)	4 (0 16)	11 (0 43)	35 (1 38)	32 (1 26)	28 (1 10)	7 (0 28)	4 (0 16)	8 (0 31)	M8 × 19 (0 75)	18 5 (40 8)
05A□ATB6	134 (5 28)	110 (4 33)	160 (6 30)	3 (0 12)	9 (0 35)	48 (1 89)	4 (0 16)	11 (0 43)	35 (1 38)	32 (1 26)	28 (1 10)	7 (0 28)	4 (0 16)	8 (0 31)	M8 × 19 (0 75)	18 5 (40 8)
05A□ATC6	134 (5 28)	110 (4 33)	160 (6 30)	3 (0 12)	9 (0 35)	48 (1 89)	4 (0 16)	11 (0 43)	35 (1 38)	32 (1 26)	28 (1 10)	7 (0 28)	4 (0 16)	8 (0 31)	M8 × 19 (0 75)	20 5 (45 2)
05A□AT76	134 (5 28)	110 (4 33)	160 (6 30)	3 (0 12)	9 (0 35)	48 (1 89)	4 (0 16)	11 (0 43)	35 (1 38)	32 (1 26)	38 (1 50)	7 (0 28)	4 (0 16)	8 (0 31)	M8 × 19 (0 75)	20 5 (45 2)
09A□ATA6	134 (5 28)	110 (4 33)	160 (6 30)	3 (0 12)	9 (0 35)	48 (1 89)	4 (0 16)	11 (0 43)	35 (1 38)	32 (1 26)	28 (1 10)	7 (0 28)	4 (0 16)	8 (0 31)	M8 × 19 (0 75)	22 6 (49 8)
09A□ATB6	134 (5 28)	110 (4 33)	160 (6 30)	3 (0 12)	9 (0 35)	48 (1 89)	4 (0 16)	11 (0 43)	35 (1 38)	32 (1 26)	28 (1 10)	7 (0 28)	4 (0 16)	8 (0 31)	M8 × 19 (0 75)	22 6 (49 8)
09A□ATC6	180 (7 09)	140 (5 51)	210 (8 27)	4 (0 16)	13 (0 51)	69 (2 72)	6 (0 24)	11 (0 43)	55 (2 17)	50 (1 97)	38 (1 50)	8 (0 31)	5 (0 20)	10 (0 39)	M10 × 22 (0 87)	33 6 (74 1)
09A□AT76	180 (7 09)	140 (5 51)	210 (8 27)	4 (0 16)	13 (0 51)	69 (2 72)	6 (0 24)	11 (0 43)	55 (2 17)	50 (1 97)	38 (1 50)	8 (0 31)	5 (0 20)	10 (0 39)	M10 × 22 (0 87)	33 6 (74 1)
13A□ATA6	134 (5 28)	110 (4 33)	160 (6 30)	3 (0 12)	9 (0 35)	48 (1 89)	4 (0 16)	11 (0 43)	35 (1 38)	32 (1 26)	28 (1 10)	7 (0 28)	4 (0 16)	8 (0 31)	M8 × 19 (0 75)	24 6 (54 2)
13A□ATB6	180 (7 09)	140 (5 51)	210 (8 27)	4 (0 16)	13 (0 51)	69 (2 72)	6 (0 24)	11 (0 43)	55 (2 17)	50 (1 97)	38 (1 50)	8 (0 31)	5 (0 20)	10 (0 39)	M10 × 22 (0 87)	35 6 (78 5)
13A□ATC6	180 (7 09)	140 (5 51)	210 (8 27)	4 (0 16)	13 (0 51)	69 (2 72)	6 (0 24)	11 (0 43)	55 (2 17)	50 (1 97)	38 (1 50)	8 (0 31)	5 (0 20)	10 (0 39)	M10 × 22 (0 87)	35 6 (78 5)
13A□AT76	230 (9 06)	200 (7 87)	260 (10 24)	4 (0 16)	15 (0 59)	76 (2 99)	6 (0 24)	11 (0 43)	70 (2 76)	56 (2 20)	50 (1 97)	9 (0 35)	5 5 (0 22)	14 (0 55)	M10 × 18 (0 71)	56 6 (124 8)
20A□ATA6	180 (7 09)	140 (5 51)	210 (8 27)	4 (0 16)	13 (0 51)	69 (2 72)	6 (0 24)	11 (0 43)	55 (2 17)	50 (1 97)	38 (1 50)	8 (0 31)	5 (0 20)	10 (0 39)	M10 × 22 (0 87)	42 (92 6)
20A□ATB6	180 (7 09)	140 (5 51)	210 (8 27)	4 (0 16)	13 (0 51)	69 (2 72)	6 (0 24)	11 (0 43)	55 (2 17)	50 (1 97)	38 (1 50)	8 (0 31)	5 (0 20)	10 (0 39)	M10 × 22 (0 87)	42 (92 6)
20A□ATC6	230 (9 06)	200 (7 87)	260 (10 24)	4 (0 16)	15 (0 59)	76 (2 99)	6 (0 24)	11 (0 43)	70 (2 76)	56 (2 20)	50 (1 97)	9 (0 35)	5 5 (0 22)	14 (0 55)	M10 × 18 (0 71)	66 (145 5)
20A□AT76	230 (9 06)	200 (7 87)	260 (10 24)	4 (0 16)	15 (0 59)	76 (2 99)	6 (0 24)	11 (0 43)	70 (2 76)	56 (2 20)	50 (1 97)	9 (0 35)	5 5 (0 22)	14 (0 55)	M10 × 18 (0 71)	66 (145 5)
30A□ATA6	180 (7 09)	140 (5 51)	210 (8 27)	4 (0 16)	13 (0 51)	69 (2 72)	6 (0 24)	11 (0 43)	55 (2 17)	50 (1 97)	38 (1 50)	8 (0 31)	5 (0 20)	10 (0 39)	M10 × 22 (0 87)	46 (101 4)
30A□ATB6	180 (7 09)	140 (5 51)	210 (8 27)	4 (0 16)	13 (0 51)	69 (2 72)	6 (0 24)	11 (0 43)	55 (2 17)	50 (1 97)	38 (1 50)	8 (0 31)	5 (0 20)	10 (0 39)	M10 × 22 (0 87)	46 (101 4)
30A□ATC6	230 (9 06)	200 (7 87)	260 (10 24)	4 (0 16)	15 (0 59)	96 (3 78)	6 (0 24)	11 (0 43)	90 (3 54)	80 (3 15)	50 (1 97)	9 (0 35)	5 5 (0 22)	14 (0 55)	M10 × 18 (0 71)	71 (156 5)

Servodrive Dimensional Drawings

4 1 3 SGMGH Servomotors (1500 r/min)

Model SGMGH-	Flange Face Dimensions mm (in)								Shaft-end Dimensions mm (in)							Approx Mass kg (lb)
	LA	LB	LC	LE	LG	LR	N	LZ	Q	QK	S	T	U	W	Tap × Depth	
30A□AT76	310 (12.20)	270 (10.63)	340 (13.39)	4 (0.16)	20 (0.79)	89 (3.50)	6 (0.24)	11 (0.43)	90 (3.54)	80 (3.15)	60 (2.36)	11 (0.43)	7 (0.28)	18 (0.71)	M10 × 18 (0.71)	121 (267)
44A□ATA6	230 (9.06)	200 (7.87)	260 (10.2)	4 (0.16)	15 (0.59)	76 (2.99)	6 (0.24)	11 (0.43)	70 (2.76)	56 (2.2)	50 (1.97)	9 (0.35)	5.5 (0.22)	14 (0.55)	M10 × 18 (0.71)	75 (165)
44A□ATB6	230 (9.06)	200 (7.87)	260 (10.2)	4 (0.16)	15 (0.59)	76 (2.99)	6 (0.24)	11 (0.43)	70 (2.76)	56 (2.2)	50 (1.97)	9 (0.35)	5.5 (0.22)	14 (0.55)	M10 × 18 (0.71)	75 (165)
44A□ATC6	310 (12.2)	270 (10.6)	340 (13.4)	4 (0.16)	20 (0.79)	89 (3.5)	6 (0.24)	11 (0.43)	90 (3.54)	80 (3.15)	60 (2.36)	11 (0.43)	7 (0.28)	18 (0.71)	M10 × 18 (0.71)	126 (278)
44A□AT76	360 (14.2)	316 (12.4)	400 (15.7)	5 (0.2)	22 (0.87)	94 (3.7)	8 (0.31)	14 (0.55)	90 (3.54)	80 (3.15)	70 (2.76)	12 (0.47)	7.5 (0.3)	20 (0.79)	M12 × 24 (0.94)	176 (388)
55A□ATA6	230 (9.06)	200 (7.87)	260 (10.2)	4 (0.16)	15 (0.59)	76 (2.99)	6 (0.24)	11 (0.43)	70 (2.76)	56 (2.2)	50 (1.97)	9 (0.35)	5.5 (0.22)	14 (0.55)	M10 × 18 (0.71)	87 (192)
55A□ATB6	230 (9.06)	200 (7.87)	260 (10.2)	4 (0.16)	15 (0.59)	96 (3.78)	6 (0.24)	11 (0.43)	90 (3.54)	80 (3.15)	50 (1.97)	9 (0.35)	5.5 (0.22)	14 (0.55)	M10 × 18 (0.71)	88 (194)
55A□ATC6	360 (14.2)	316 (12.4)	400 (15.7)	5 (0.2)	22 (0.87)	94 (3.7)	8 (0.31)	14 (0.55)	90 (3.54)	80 (3.15)	70 (2.76)	12 (0.47)	7.5 (0.3)	20 (0.79)	M12 × 24 (0.94)	191 (421)
55A□AT76	360 (14.2)	316 (12.4)	400 (15.7)	5 (0.2)	22 (0.87)	94 (3.7)	8 (0.31)	14 (0.55)	90 (3.54)	80 (3.15)	70 (2.76)	12 (0.47)	7.5 (0.3)	20 (0.79)	M12 × 24 (0.94)	191 (421)
75A□ATB6	310 (12.2)	270 (10.6)	340 (13.4)	4 (0.16)	20 (0.79)	89 (3.5)	6 (0.24)	11 (0.43)	90 (3.54)	80 (3.15)	60 (2.36)	11 (0.43)	7 (0.28)	18 (0.71)	M10 × 18 (0.71)	150 (331)
75A□ATC6	360 (14.2)	316 (12.4)	400 (15.7)	5 (0.2)	22 (0.87)	94 (3.7)	8 (0.31)	14 (0.55)	90 (3.54)	80 (3.15)	70 (2.76)	12 (0.47)	7.5 (0.3)	20 (0.79)	M12 × 24 (0.94)	201 (443)
75A□AT76	390 (15.4)	345 (13.6)	430 (16.9)	5 (0.2)	22 (0.87)	110 (4.33)	8 (0.31)	18 (0.71)	110 (4.33)	100 (3.94)	80 (3.15)	14 (0.55)	9 (0.35)	22 (0.87)	M12 × 24 (0.94)	232 (511)

• Dimensional Tolerances

Model SGMGH-	Flange Face Dimensions mm (in)	Shaft-end Dimensions mm (in)
	LB	S
05A□ATA6	110 ^{-0.036} / _{-0.090} (4.33 ^{-0.0014} / _{-0.0035})	28 ⁰ / _{-0.013} (1.11 ⁰ / _{-0.0005})
05A□ATB6	110 ^{-0.036} / _{-0.090} (4.33 ^{-0.0014} / _{-0.0035})	28 ⁰ / _{-0.013} (1.11 ⁰ / _{-0.0005})
05A□ATC6	110 ^{-0.036} / _{-0.090} (4.33 ^{-0.0014} / _{-0.0035})	28 ⁰ / _{-0.013} (1.11 ⁰ / _{-0.0005})
05A□AT76	110 ^{-0.036} / _{-0.090} (4.33 ^{-0.0014} / _{-0.0035})	38 ⁰ / _{-0.016} (1.51 ⁰ / _{-0.0006})
09A□ATA6	110 ^{-0.036} / _{-0.090} (4.33 ^{-0.0014} / _{-0.0035})	28 ⁰ / _{-0.013} (1.11 ⁰ / _{-0.0005})
09A□ATB6	110 ^{-0.036} / _{-0.090} (4.33 ^{-0.0014} / _{-0.0035})	28 ⁰ / _{-0.013} (1.11 ⁰ / _{-0.0005})
09A□ATC6	140 ^{-0.043} / _{-0.090} (5.51 ^{-0.0017} / _{-0.0035})	38 ⁰ / _{-0.016} (1.51 ⁰ / _{-0.0006})
09A□AT76	140 ^{-0.043} / _{-0.090} (5.51 ^{-0.0017} / _{-0.0035})	38 ⁰ / _{-0.016} (1.51 ⁰ / _{-0.0006})
13A□ATA6	110 ^{-0.036} / _{-0.090} (4.33 ^{-0.0014} / _{-0.0035})	28 ⁰ / _{-0.013} (1.11 ⁰ / _{-0.0005})
13A□ATB6	140 ^{-0.043} / _{-0.090} (5.51 ^{-0.0017} / _{-0.0035})	38 ⁰ / _{-0.016} (1.51 ⁰ / _{-0.0006})
13A□ATC6	140 ^{-0.043} / _{-0.090} (5.51 ^{-0.0017} / _{-0.0035})	38 ⁰ / _{-0.016} (1.51 ⁰ / _{-0.0006})
13A□AT76	200 ^{-0.050} / _{-0.122} (7.87 ^{-0.0020} / _{-0.0048})	50 ⁰ / _{-0.016} (1.98 ⁰ / _{-0.0006})

Model SGMGH-	Flange Face Dimensions mm (in)		Shaft-end Dimensions mm (in)	
	LB		S	
20A□ATA6	140 ^{-0.043} _{-0.090}	(5.51 ^{-0.0017} _{-0.0035})	38 ⁰ _{-0.016}	(1.51 ⁰ _{-0.0006})
20A□ATB6	140 ^{-0.043} _{-0.090}	(5.51 ^{-0.0017} _{-0.0035})	38 ⁰ _{-0.016}	(1.51 ⁰ _{-0.0006})
20A□ATC6	200 ^{-0.050} _{-0.122}	(7.87 ^{-0.0020} _{-0.0048})	50 ⁰ _{-0.016}	(1.98 ⁰ _{-0.0006})
20A□AT76	200 ^{-0.050} _{-0.122}	(7.87 ^{-0.0020} _{-0.0048})	50 ⁰ _{-0.016}	(1.98 ⁰ _{-0.0006})
30A□ATA6	140 ^{-0.043} _{-0.090}	(5.51 ^{-0.0017} _{-0.0035})	38 ⁰ _{-0.016}	(1.51 ⁰ _{-0.0006})
30A□ATB6	140 ^{-0.043} _{-0.090}	(5.51 ^{-0.0017} _{-0.0035})	38 ⁰ _{-0.016}	(1.51 ⁰ _{-0.0006})
30A□ATC6	200 ^{-0.050} _{-0.122}	(7.87 ^{-0.0020} _{-0.0048})	50 ⁰ _{-0.016}	(1.98 ⁰ _{-0.0006})
30A□AT76	270 ^{-0.056} _{-0.137}	(10.63 ^{-0.0022} _{-0.0054})	60 ⁰ _{-0.019}	(2.38 ⁰ _{-0.0008})
44A□ATA6	200 ^{-0.050} _{-0.122}	(7.87 ^{-0.0020} _{-0.0048})	50 ⁰ _{-0.016}	(1.98 ⁰ _{-0.0006})
44A□ATB6	200 ^{-0.050} _{-0.122}	(7.87 ^{-0.0020} _{-0.0048})	50 ⁰ _{-0.016}	(1.98 ⁰ _{-0.0006})
44A□ATC6	270 ^{-0.056} _{-0.137}	(10.63 ^{-0.0022} _{-0.0054})	60 ⁰ _{-0.019}	(2.38 ⁰ _{-0.0008})
44A□AT76	316 ^{-0.062} _{-0.151}	(12.44 ^{-0.0024} _{-0.0059})	70 ⁰ _{-0.019}	(2.78 ⁰ _{-0.0008})
55A□ATA6	200 ^{-0.050} _{-0.122}	(7.87 ^{-0.0020} _{-0.0048})	50 ⁰ _{-0.016}	(1.98 ⁰ _{-0.0006})
55A□ATB6	200 ^{-0.050} _{-0.122}	(7.87 ^{-0.0020} _{-0.0048})	50 ⁰ _{-0.016}	(1.98 ⁰ _{-0.0006})
55A□ATC6	316 ^{-0.062} _{-0.151}	(12.44 ^{-0.0024} _{-0.0059})	70 ⁰ _{-0.019}	(2.78 ⁰ _{-0.0008})
55A□AT76	316 ^{-0.062} _{-0.151}	(12.44 ^{-0.0024} _{-0.0059})	70 ⁰ _{-0.019}	(2.78 ⁰ _{-0.0008})
75A□ATB6	270 ^{-0.056} _{-0.137}	(10.63 ^{-0.0022} _{-0.0054})	60 ⁰ _{-0.019}	(2.38 ⁰ _{-0.0008})
75A□ATC6	316 ^{-0.062} _{-0.151}	(12.44 ^{-0.0024} _{-0.0059})	70 ⁰ _{-0.019}	(2.78 ⁰ _{-0.0008})
75A□AT76	345 ^{-0.062} _{-0.151}	(13.6 ^{-0.0024} _{-0.0059})	80 ⁰ _{-0.022}	(3.1 ⁰ _{-0.0008})



■ Servomotors Without Brakes and With Low-Backlash Gears for 1500 r/min

Flange Type

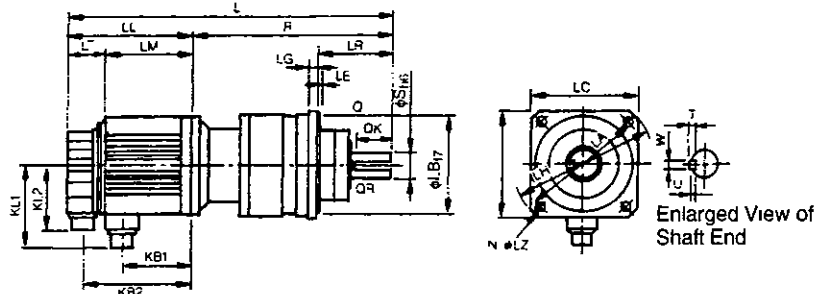

Figure 4.6 Smaller Grease Lubricating Type

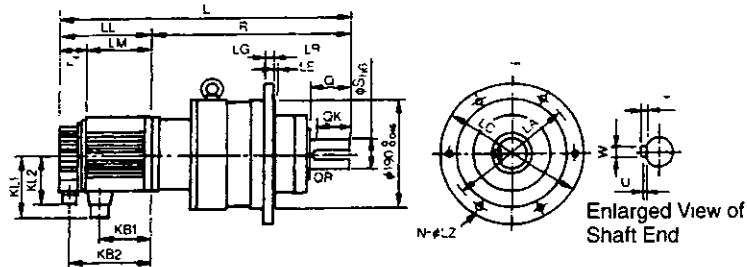
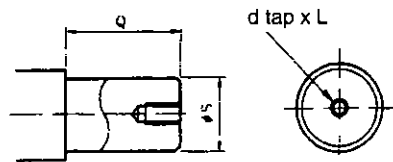

Figure 4.7 Larger Grease Lubricating Type

● Applied Specifications of Shaft End Tap



Gear Frame No.	Shaft Diameter (S)	Shaft Length (Q)	d x L (mm)
BL2	35	55	M8 x 16
BL3	50	75	M10 x 20
BL4	60	90	M12 x 24

● Enlarged View of IMT Gear

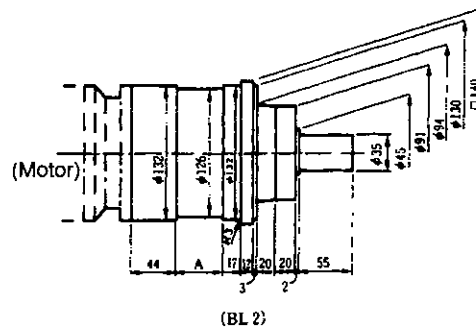

Gear Ratio	A
1/5	6
1/9	18
1/20, 1/29	39
1/45	47

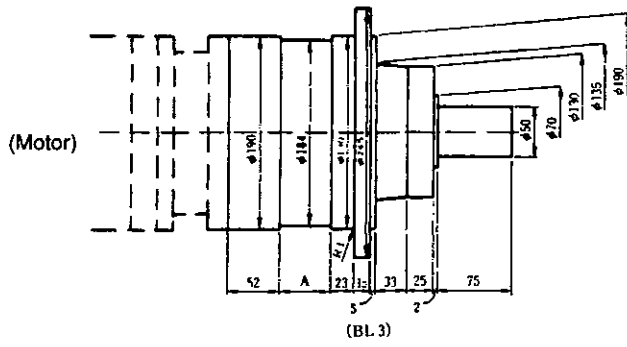

Gear Ratio	A
1/5	11
1/9	38
1/20, 1/29	46
1/45	52

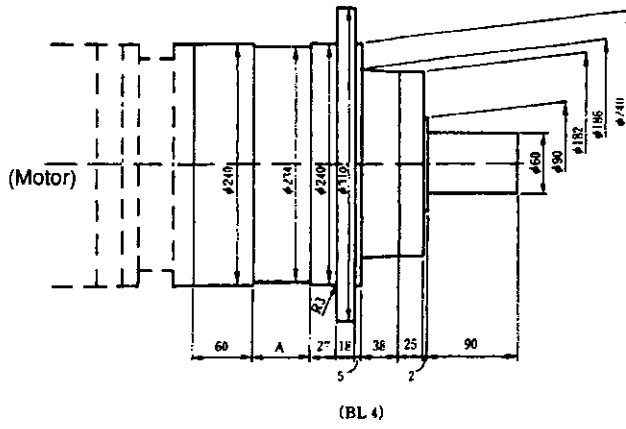

Gear Ratio	A
1/5	16
1/9	48
1/20, 1/29	55
1/45	58



Table 4 35 Servomotors Without Brakes and With Low-Backlash Gears for 1500 r/min (L to R)

Model SGMGH-	Gear Type	Gear Ratio	Fig No	L	LL	LM	LR	LT	KB1	KB2	KL1	KL2	R	Allowable Radial Load on Center of Shaft N (lbf)
05A□AL14	BL2	1/5	4 6	394 (15 5)	138 (5 43)	92 (3 62)	100 (3 94)	46 (1 81)	65 (2 56)	117 (4 61)	109 (4 29)	88 (3 46)	256 (10 1)	833 (187)
05A□AL24		1/3	4 6	406 (16)	138 (5 43)	92 (3 62)	100 (3 94)	46 (1 81)	65 (2 56)	117 (4 61)	109 (4 29)	88 (3 46)	268 (10 6)	980 (220)
05A□AL54	BL3	1/20	4 7	491 (19 3)	138 (5 43)	92 (3 62)	140 (5 51)	46 (1 81)	65 (2 56)	117 (4 61)	109 (4 29)	88 (3 46)	353 (13 9)	2650 (595)
05A□AL74		1/29	4 7	491 (19 3)	138 (5 43)	92 (3 62)	140 (5 51)	46 (1 81)	65 (2 56)	117 (4 61)	109 (4 29)	88 (3 46)	353 (13 9)	2940 (660)
05A□AL84		1/45	4 7	501 (19 7)	138 (5 43)	92 (3 62)	140 (5 51)	46 (1 81)	65 (2 56)	117 (4 61)	109 (4 29)	88 (3 46)	363 (14 3)	3430 (770)
09A□AL14	BL2	1/5	4 6	417 (16 4)	161 (6 34)	115 (4 53)	100 (3 94)	46 (1 81)	88 (3 46)	140 (5 51)	109 (4 29)	88 (3 46)	256 (10 1)	833 (187)
09A□AL24		1/9	4 6	429 (16 9)	161 (6 34)	115 (4 53)	100 (3 94)	46 (1 81)	88 (3 46)	140 (5 51)	109 (4 29)	88 (3 46)	268 (10 6)	980 (220)
09A□AL54	BL3	1/20	4 7	514 (20 2)	161 (6 34)	115 (4 53)	140 (5 51)	46 (1 81)	88 (3 46)	140 (5 51)	109 (4 29)	88 (3 46)	353 (13 9)	2650 (595)
09A□AL74		1/29	4 7	514 (20 2)	161 (6 34)	115 (4 53)	140 (5 51)	46 (1 81)	88 (3 46)	140 (5 51)	109 (4 29)	88 (3 46)	353 (13 9)	2940 (660)
09A□AL84	BL4	1/45	4 7	565 (22 2)	161 (6 34)	115 (4 53)	160 (6 3)	46 (1 81)	88 (3 46)	140 (5 51)	109 (4 29)	88 (3 46)	404 (15 9)	8040 (405)
13A□AL14	BL3	1/5	4 7	507 (2)	185 (7 28)	139 (5 47)	140 (5 51)	46 (1 81)	112 (4 41)	164 (6 46)	109 (4 29)	88 (3 46)	322 (12 7)	1670 (375)
13A□AL24		1/9	4 7	534 (21)	185 (7 28)	139 (5 47)	140 (5 51)	46 (1 81)	112 (4 41)	164 (6 46)	109 (4 29)	88 (3 46)	349 (13 7)	1960 (440)
13A□AL54		1/20	4 7	538 (21 2)	185 (7 28)	139 (5 47)	140 (5 51)	46 (1 81)	112 (4 41)	164 (6 46)	109 (4 29)	88 (3 46)	353 (13 9)	2650 (595)
13A□AL74	BL4	1/29	4 7	579 (22 8)	185 (7 28)	139 (5 47)	160 (6 3)	46 (1 81)	112 (4 41)	164 (6 46)	109 (4 29)	88 (3 46)	394 (15 5)	6860 (1540)
13A□AL84		1/45	4 7	589 (23 2)	185 (7 28)	139 (5 47)	160 (6 3)	46 (1 81)	112 (4 41)	164 (6 46)	109 (4 29)	88 (3 46)	404 (15 9)	8040 (405)
20A□AL14	BL3	1/5	4 7	509 (2)	166 (6 54)	119 (4 69)	140 (5 51)	47 (1 85)	89 (3 5)	145 (5 71)	140 (5 51)	88 (3 46)	343 (13 5)	1670 (375)
20A□AL24		1/9	4 7	536 (21 1)	166 (6 54)	119 (4 69)	140 (5 51)	47 (1 85)	89 (3 5)	145 (5 71)	140 (5 51)	88 (3 46)	370 (14 6)	1960 (440)
20A□AL54	BL4	1/20	4 7	581 (22 9)	166 (6 54)	119 (4 69)	160 (6 3)	47 (1 85)	89 (3 5)	145 (5 71)	140 (5 51)	88 (3 46)	415 (16 3)	6080 (1365)
20A□AL74		1/29	4 7	581 (22 9)	166 (6 54)	119 (4 69)	160 (6 3)	47 (1 85)	89 (3 5)	145 (5 71)	140 (5 51)	88 (3 46)	415 (16 3)	6860 (1540)
30A□AL14	BL4	1/5	4 7	575 (22 6)	192 (7 56)	145 (5 71)	160 (6 3)	47 (1 85)	115 (4 53)	171 (6 73)	140 (5 51)	88 (3 46)	383 (15 1)	3820 (858)
30A□AL24		1/9	4 7	607 (23 9)	192 (7 56)	145 (5 71)	160 (6 3)	47 (1 85)	115 (4 53)	171 (6 73)	140 (5 51)	88 (3 46)	415 (16 3)	4700 (1055)
30A□AL54		1/20	4 7	607 (23 9)	192 (7 56)	145 (5 71)	160 (6 3)	47 (1 85)	115 (4 53)	171 (6 73)	140 (5 51)	88 (3 46)	415 (16 3)	6080 (1365)
44A□AL14	BL4	1/5	4 7	609 (24)	226 (8 9)	179 (7 05)	160 (6 3)	47 (1 85)	149 (5 87)	205 (8 07)	140 (5 51)	88 (3 46)	383 (15 1)	3820 (858)
44A□AL24		1/9	4 7	641 (25 2)	226 (8 9)	179 (7 05)	160 (6 3)	47 (1 85)	149 (5 87)	205 (8 07)	140 (5 51)	88 (3 46)	415 (16 3)	4700 (1055)

Table 4.36 Servomotors Without Brakes and With Low-Backlash Gears for 1500 r/min (LA to W)

Model SGMGH-	Flange Face Dimensions mm (in)								Shaft-end Dimensions mm (in)								Approx Mass kg (lb)
	LA	LB	LC	LE	LG	LH	N	LZ	Q	QK	QR	S	T	U	W		
05A□AL14	160 (6.3)	130 (5.12)	140 (5.51)	3 (0.12)	12 (0.47)	185 (7.28)	4 (0.16)	12 (0.47)	55 (2.17)	47 (1.85)	1 (0.039)	35 (1.38)	8 (0.31)	5 (0.2)	10 (0.39)	14 (30.9)	
05A□AL24	160 (6.3)	130 (5.12)	140 (5.51)	3 (0.12)	12 (0.47)	185 (7.28)	4 (0.16)	12 (0.47)	55 (2.17)	47 (1.85)	1 (0.039)	35 (1.38)	8 (0.31)	5 (0.2)	10 (0.39)	14 (30.9)	
05A□AL54	220 (8.66)	190 (7.48)	245 (9.65)	5 (0.2)	15 (0.59)	-	6 (0.24)	12 (0.47)	75 (2.95)	65 (2.56)	1 (0.039)	50 (1.97)	9 (0.35)	5.5 (0.22)	14 (0.55)	31 (68.3)	
05A□AL74	220 (8.66)	190 (7.48)	245 (9.65)	5 (0.2)	15 (0.59)	-	6 (0.24)	12 (0.47)	75 (2.95)	65 (2.56)	1 (0.039)	50 (1.97)	9 (0.35)	5.5 (0.22)	14 (0.55)	31 (68.3)	
05A□AL84	220 (8.66)	190 (7.48)	245 (9.65)	5 (0.2)	15 (0.59)	-	6 (0.24)	12 (0.47)	75 (2.95)	65 (2.56)	1 (0.039)	50 (1.97)	9 (0.35)	5.5 (0.22)	14 (0.55)	31 (68.3)	
09A□AL14	160 (6.3)	130 (5.12)	140 (5.51)	3 (0.12)	12 (0.47)	185 (7.28)	4 (0.16)	12 (0.47)	55 (2.17)	47 (1.85)	1 (0.039)	35 (1.38)	8 (0.31)	5 (0.2)	10 (0.39)	16 (35.3)	
09A□AL24	160 (6.3)	130 (5.12)	140 (5.51)	3 (0.12)	12 (0.47)	185 (7.28)	4 (0.16)	12 (0.47)	55 (2.17)	47 (1.85)	1 (0.039)	35 (1.38)	8 (0.31)	5 (0.2)	10 (0.39)	16 (35.3)	
09A□AL54	220 (8.66)	190 (7.48)	245 (9.65)	5 (0.2)	15 (0.59)	-	6 (0.24)	12 (0.47)	75 (2.95)	65 (2.56)	1 (0.039)	50 (1.97)	9 (0.35)	5.5 (0.22)	14 (0.55)	33 (72.8)	
09A□AL74	220 (8.66)	190 (7.48)	245 (9.65)	5 (0.2)	15 (0.59)	-	6 (0.24)	12 (0.47)	75 (2.95)	65 (2.56)	1 (0.039)	50 (1.97)	9 (0.35)	5.5 (0.22)	14 (0.55)	33 (72.8)	
09A□AL84	280 (11)	240 (9.45)	310 (12.2)	5 (0.2)	18 (0.71)	-	6 (0.24)	14 (0.55)	90 (3.54)	78 (3.07)	1 (0.039)	60 (2.36)	11 (0.43)	7 (0.28)	18 (0.71)	53 (117)	
13A□AL14	220 (8.66)	190 (7.48)	245 (9.65)	5 (0.2)	15 (0.59)	-	6 (0.24)	12 (0.47)	75 (2.95)	65 (2.56)	1 (0.039)	50 (1.97)	9 (0.35)	5.5 (0.22)	14 (0.55)	28 (61.7)	
13A□AL24	220 (8.66)	190 (7.48)	245 (9.65)	5 (0.2)	15 (0.59)	-	6 (0.24)	12 (0.47)	75 (2.95)	65 (2.56)	1 (0.039)	50 (1.97)	9 (0.35)	5.5 (0.22)	14 (0.55)	35 (77.2)	
13A□AL54	220 (8.66)	190 (7.48)	245 (9.65)	5 (0.2)	15 (0.59)	-	6 (0.24)	12 (0.47)	75 (2.95)	65 (2.56)	1 (0.039)	50 (1.97)	9 (0.35)	5.5 (0.22)	14 (0.55)	35 (77.2)	
13A□AL74	280 (11)	240 (9.45)	310 (12.2)	5 (0.2)	18 (0.71)	-	6 (0.24)	14 (0.55)	90 (3.54)	78 (3.07)	1 (0.039)	60 (2.36)	11 (0.43)	7 (0.28)	18 (0.71)	55 (121)	
13A□AL84	280 (11)	240 (9.45)	310 (12.2)	5 (0.2)	18 (0.71)	-	6 (0.24)	14 (0.55)	90 (3.54)	78 (3.07)	1 (0.039)	60 (2.36)	11 (0.43)	7 (0.28)	18 (0.71)	55 (121)	
20A□AL14	220 (8.66)	190 (7.48)	245 (9.65)	5 (0.2)	15 (0.59)	-	6 (0.24)	12 (0.47)	75 (2.95)	65 (2.56)	1 (0.039)	50 (1.97)	9 (0.35)	5.5 (0.22)	14 (0.55)	32 (70.5)	
20A□AL24	220 (8.66)	190 (7.48)	245 (9.65)	5 (0.2)	15 (0.59)	-	6 (0.24)	12 (0.47)	75 (2.95)	65 (2.56)	1 (0.039)	50 (1.97)	9 (0.35)	5.5 (0.22)	14 (0.55)	39 (86)	
20A□AL54	280 (11)	240 (9.45)	310 (12.2)	5 (0.2)	18 (0.71)	-	6 (0.24)	14 (0.55)	90 (3.54)	78 (3.07)	1 (0.039)	60 (2.36)	11 (0.43)	7 (0.28)	18 (0.71)	39 (86)	
20A□AL74	280 (11)	240 (9.45)	310 (12.2)	5 (0.2)	18 (0.71)	-	6 (0.24)	14 (0.55)	90 (3.54)	78 (3.07)	1 (0.039)	60 (2.36)	11 (0.43)	7 (0.28)	18 (0.71)	39 (86)	
30A□AL14	280 (11)	240 (9.45)	310 (12.2)	5 (0.2)	18 (0.71)	-	6 (0.24)	14 (0.55)	90 (3.54)	78 (3.07)	1 (0.039)	60 (2.36)	11 (0.43)	7 (0.28)	18 (0.71)	53 (117)	
30A□AL24	280 (11)	240 (9.45)	310 (12.2)	5 (0.2)	18 (0.71)	-	6 (0.24)	14 (0.55)	90 (3.54)	78 (3.07)	1 (0.039)	60 (2.36)	11 (0.43)	7 (0.28)	18 (0.71)	63 (139)	
30A□AL54	280 (11)	240 (9.45)	310 (12.2)	5 (0.2)	18 (0.71)	-	6 (0.24)	14 (0.55)	90 (3.54)	78 (3.07)	1 (0.039)	60 (2.36)	11 (0.43)	7 (0.28)	18 (0.71)	63 (139)	
44A□AL14	280 (11)	240 (9.45)	310 (12.2)	5 (0.2)	18 (0.71)	-	6 (0.24)	14 (0.55)	90 (3.54)	78 (3.07)	1 (0.039)	60 (2.36)	11 (0.43)	7 (0.28)	18 (0.71)	58 (128)	
44A□AL24	280 (11)	240 (9.45)	310 (12.2)	5 (0.2)	18 (0.71)	-	6 (0.24)	14 (0.55)	90 (3.54)	78 (3.07)	1 (0.039)	60 (2.36)	11 (0.43)	7 (0.28)	18 (0.71)	68 (150)	

4.1.4 SGMGH Servomotors (1000 r/min)

- SGMGH-□□ A2B Servomotors with 17-bit Absolute Encoders and SGMGH-□□ ACB Servomotors with 17-bit Incremental Encoders

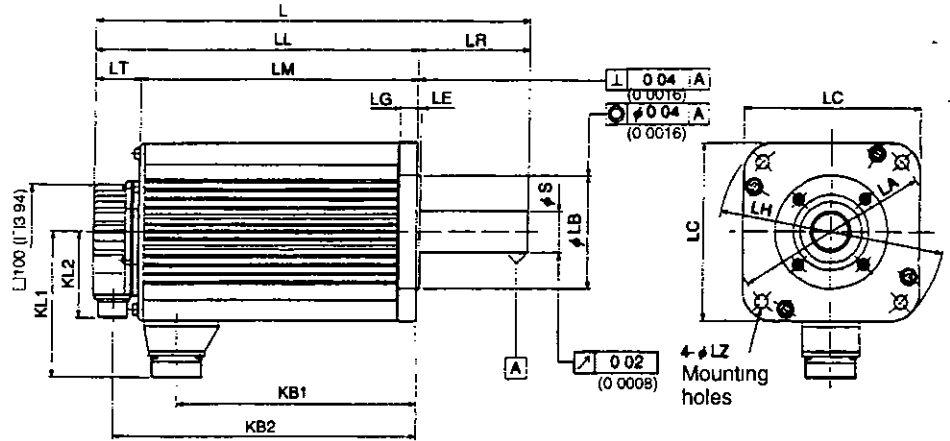

Enlarged View of Shaft End

SGMGH-03A2B to 09A2B
SGMGH-03ACB to 09ACB

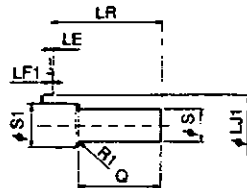

SGMGH-12A2B to 55A2B
SGMGH-12ACB to 55ACB

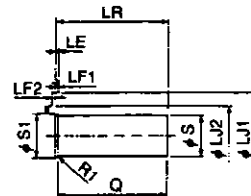

Table 4.37 SGMGH-□□ A2B Servomotors with 17-bit Absolute Encoders and SGMGH-□□ ACB Servomotors with 17-bit Incremental Encoders (L to KL2)

Units mm (in)

Model SGMGH-	L	LL	LM	LR	LT	KB1	KB2	IE	KL1	KL2
03A□B	196 (7 72)	138 (5 43)	92 (3 62)	58 (2 28)	46 (1 81)	65 (2 56)	117 (4 61)	-	109 (4 29)	88 (3 46)
06A□B	219 (8 62)	161 (6 34)	115 (4 53)	58 (2 28)	46 (1 81)	88 (3 46)	140 (5 51)	-	109 (4 29)	88 (3 46)
09A□B	243 (9 57)	185 (7 28)	139 (5 47)	58 (2 28)	46 (1 81)	112 (4 41)	164 (6 46)	-	109 (4 29)	88 (3 46)
12A□B	245 (9 65)	166 (6 54)	119 (4 69)	79 (3 11)	47 (1 85)	89 (3 50)	145 (5 71)	-	140 (5 51)	88 (3 46)
20A□B	271 (10 67)	192 (7 56)	145 (5 71)	79 (3 11)	47 (1 85)	115 (4 53)	171 (6 73)	-	140 (5 51)	88 (3 46)
30A□B	305 (12 01)	226 (8 90)	179 (7 05)	79 (3 11)	47 (1 85)	149 (5 87)	205 (8 07)	-	140 (5 51)	88 (3 46)
40A□B	373 (14 7)	260 (10 2)	213 (8 39)	113 (4 45)	47 (1 85)	174 (6 85)	239 (9 41)	125 (4 92)	150 (5 91)	88 (3 46)
55A□B	447 (17 6)	334 (13 1)	287 (11 3)	113 (4 45)	47 (1 85)	248 (9 76)	313 (12 3)	125 (4 92)	150 (5 91)	88 (3 46)

Table 4.38 SGMGH-□□ A2B Servomotors with 17-bit Absolute Encoders and SGMGH-□□ ACB Servomotors with 17-bit Incremental Encoders (LA to Q)

Model SGMGH-	Flange Face Dimensions mm (in)											Shaft-end Dimensions mm (in)			Approx Mass kg (lb)
	LA	LB	LC	LE	LF1	LF2	LG	LH	LJ1	LJ2	LZ	S	S1	Q	
03A□B	145 (5 71)	$\begin{matrix} 0 \\ 110 -0.035 \\ 0 \\ (4.33 -0.0014) \end{matrix}$	130 (5 12)	6 (0 24)	6 (0 24)	-	12 (0 47)	165 (6 50)	45 (1 77)	-	9 (0 35)	$\begin{matrix} 0 \\ 19 -0.013 \\ 0 \\ (0.75 -0.0005) \end{matrix}$	30 (1 18)	40 (1 57)	5 5 (12 16)
06A□B	145 (5 71)	$\begin{matrix} 0 \\ 110 -0.035 \\ 0 \\ (4.33 -0.0014) \end{matrix}$	130 (5 12)	6 (0 24)	6 (0 24)	-	12 (0 47)	165 (6 50)	45 (1 77)	-	9 (0 35)	$\begin{matrix} 0 \\ 19 -0.013 \\ 0 \\ (0.75 -0.0005) \end{matrix}$	30 (1 18)	40 (1 57)	7 6 (16 76)
09A□B	145 (5 71)	$\begin{matrix} 0 \\ 110 -0.035 \\ 0 \\ (4.33 -0.0014) \end{matrix}$	130 (5 12)	6 (0 24)	6 (0 24)	-	12 (0 47)	165 (6 50)	45 (1 77)	-	9 (0 35)	$\begin{matrix} 0 \\ 22 -0.013 \\ 0 \\ (0.87 -0.0005) \end{matrix}$	30 (1 18)	40 (1 57)	9 6 (21 2)
12A□B	200 (7 87)	$\begin{matrix} 0 \\ 114.3 -0.025 \\ 0 \\ (4.50 -0.0010) \end{matrix}$	180 (7 09)	3.2 (0 13)	3 (0 12)	0.5 (0 020)	18 (0 71)	230 (9 06)	76 (2 99)	62 (2 44)	13.5 (0 53)	$\begin{matrix} +0.01 \\ 35 \\ 0 \\ (1.38 \\ 0 \\ 0.0004) \end{matrix}$	45 (1 77)	76 (2 99)	14 (30 9)
20A□B	200 (7 87)	$\begin{matrix} 0 \\ 114.3 -0.025 \\ 0 \\ (4.50 -0.0010) \end{matrix}$	180 (7 09)	3.2 (0 13)	3 (0 12)	0.5 (0 020)	18 (0 71)	230 (9 06)	76 (2 99)	62 (2 44)	13.5 (0 53)	$\begin{matrix} +0.01 \\ 35 \\ 0 \\ (1.38 \\ 0 \\ 0.0004) \end{matrix}$	45 (1 77)	76 (2 99)	18 (39 7)
30A□B	200 (7 87)	$\begin{matrix} 0 \\ 114.3 -0.025 \\ 0 \\ (4.50 -0.0010) \end{matrix}$	180 (7 09)	3.2 (0 13)	3 (0 12)	0.5 (0 020)	18 (0 71)	230 (9 06)	76 (2 99)	62 (2 44)	13.5 (0 53)	$\begin{matrix} +0.01 \\ 35 \\ 0 \\ (1.38 \\ 0 \\ 0.0004) \end{matrix}$	45 (1 77)	110 (4 33)	30 (66 1)

Servodrive Dimensional Drawings

4 1 4 SGMGH Servomotors (1000 r/min)

Model SGMGH-	Flange Face Dimensions mm (in)											Shaft-end Dimensions mm (in)			Approx. Mass kg (lb)
	LA	LB	LC	LE	LF1	LF2	LG	LH	LJ1	LJ2	LZ	S	S1	Q	
40A□B	200 (7.87)	$114.3^{+0.025}_0$ $(4.50^{+0.0010}_0)$	180 (7.09)	$3.2^{+0.13}_0$ (0.12)	$3^{+0.12}_0$ (0.020)	0.5 (0.020)	18 (0.71)	230 (9.06)	76 (2.99)	62 (2.44)	13.5 (0.53)	$42^{+0.016}_0$ $(1.65^{+0.0006}_0)$	45 (1.77)	110 (4.33)	30 (66.1)
55A□B	200 (7.87)	$114.3^{+0.025}_0$ $(4.50^{+0.0010}_0)$	180 (7.09)	$3.2^{+0.13}_0$ (0.12)	$3^{+0.12}_0$ (0.020)	0.5 (0.020)	18 (0.71)	230 (9.06)	76 (2.99)	62 (2.44)	13.5 (0.53)	$42^{+0.016}_0$ $(1.65^{+0.0006}_0)$	45 (1.77)	110 (4.33)	40 (88.2)

Note The detector is a 17-bit encoder (absolute/incremental)

Cable Specifications for Detector Connectors (17-bit Encoder)

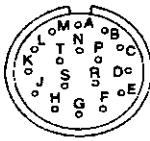

Receptacle MS3102A20-29P
 Applicable plug (purchased by the customer)
 Plug MS3108B20-29S
 Cable clamp MS3057-12A

• Servomotors with Absolute Encoders

A	-	K	-
B	-	L	-
C	DATA+	M	-
D	DATA-	N	-
E	-	P	-
F	-	R	-
G	0V	S	BATT-
H	+5VDC	T	BATT+
J	FG (Frame ground)		-

• Servomotors with Incremental Encoders

A	-	K	-
B	-	L	-
C	DATA+	M	-
D	DATA-	N	-
E	-	P	-
F	-	R	-
G	0V	S	-
H	+5VDC	T	-
J	FG (Frame ground)		-

Cable Specifications for Servomotor Connectors



A	Phase U
B	Phase V
C	Phase W
D	FG (Frame ground)

■ Servomotors with 17-bit Encoders (Absolute/Incremental) and Brakes

- 0.3 to 3.0 kW

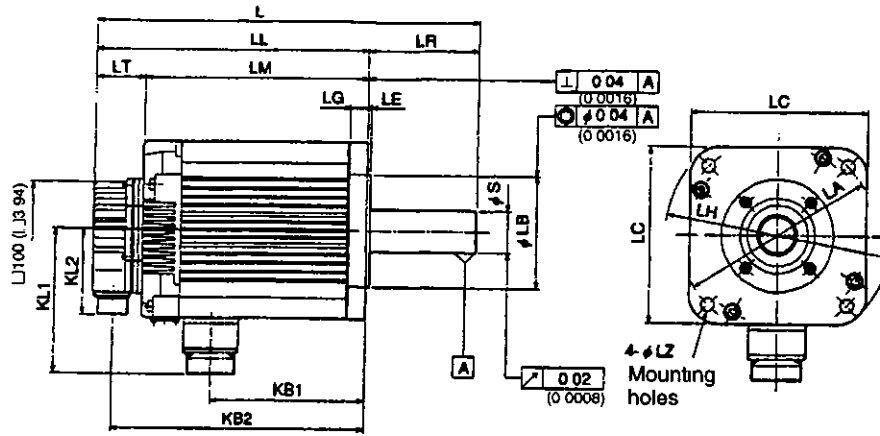

Enlarged View of Shaft End

SGMGH-03A2B□B to
09A2B□B, SGMGH-03ACB□B to
09ACB□B

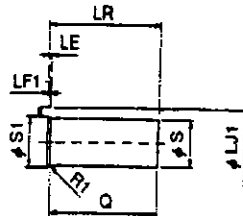

SGMGH-12A2B□B to
30A2B□B, SGMGH-12ACB□B to
30ACB□B

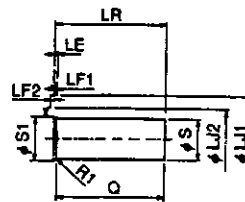

Table 4.39 Servomotors with 17-bit Encoders (Absolute/Incremental) and Brakes
(SGMGH-03A□B□B to 30A□B□B, L to KL2) Units mm (in)

Model SGMGH-	L	LL	LM	LR	LT	KB1	KB2	KL1	KL2
03A□B□B	234 (9 21)	176 (6 93)	129 (5 08)	58 (2 28)	47 (1 85)	56 (2 20)	155 (6 10)	120 (4 72)	88 (3 46)
06A□B□B	257 (10 12)	199 (7 83)	152 (5 98)	58 (2 28)	47 (1 85)	79 (3 11)	178 (7 01)	120 (4 72)	88 (3 46)
09A□B□B	281 (11 06)	223 (8 78)	176 (6 93)	58 (2 28)	47 (1 85)	103 (4 06)	202 (7 95)	120 (4 72)	88 (3 46)
12A□B□B	296 (11 65)	217 (8 54)	170 (6 69)	79 (3 11)	47 (1 85)	79 (3 11)	196 (7 72)	146 (5 75)	88 (3 46)
20A□B□B	322 (12 68)	243 (9 57)	196 (7 72)	79 (3 11)	47 (1 85)	105 (4 13)	222 (8 74)	146 (5 75)	88 (3 46)
30A□B□B	356 (14 02)	277 (10 91)	230 (9 06)	79 (3 11)	47 (1 85)	139 (5 47)	256 (10 08)	146 (5 75)	88 (3 46)

Servodrive Dimensional Drawings

4 1 4 SGMGH Servomotors (1000 r/min)

Table 4.40 Servomotors with 17-bit Encoders (Absolute/Incremental) and Brake (SGMGH-03A□B□B to 30A□B□B, LA to Q)

Model SGMGH-	Flange Face Dimensions mm (in)											Shaft-end Dimensions mm (in)			Approx Mass kg (lb)
	LA	LB	LC	LE	LF1	LF2	LG	LH	LJ1	LJ2	LZ	S	S1	Q	
03A□B□B	145 (5.71)	$110_{-0.035}^0$ $(4.33_{-0.0014}^0)$	130 (5.12)	6 (0.24)	6 (0.24)	-	12 (0.47)	165 (6.50)	45 (1.77)	-	9 (0.35)	$19_{-0.013}^0$ $(0.75_{-0.0005}^0)$	30 (1.18)	40 (1.57)	7.5 (16.54)
06A□B□B	145 (5.71)	$110_{-0.035}^0$ $(4.33_{-0.0014}^0)$	130 (5.12)	6 (0.24)	6 (0.24)	-	12 (0.47)	165 (6.50)	45 (1.77)	-	9 (0.35)	$19_{-0.013}^0$ $(0.75_{-0.0005}^0)$	30 (1.18)	40 (1.57)	9.6 (21.2)
09A□B□B	145 (5.71)	$110_{-0.035}^0$ $(4.33_{-0.0014}^0)$	130 (5.12)	6 (0.24)	6 (0.24)	-	12 (0.47)	165 (6.50)	45 (1.77)	-	9 (0.35)	$22_{-0.013}^0$ $(0.87_{-0.0005}^0)$	30 (1.18)	40 (1.57)	12 (26.5)
12A□B□B	200 (7.87)	$114.3_{-0.025}^0$ $(4.50_{-0.0010}^0)$	180 (7.09)	3.2 (0.13)	3 (0.12)	0.5 (0.020)	18 (0.71)	230 (9.06)	76 (2.99)	62 (2.44)	13.5 (0.53)	$35_{-0.01}^0$ $(1.38_{-0.0004}^0)$	45 (1.77)	76 (2.99)	19 (41.9)
20A□B□B	200 (7.87)	$114.3_{-0.025}^0$ $(4.50_{-0.0010}^0)$	180 (7.09)	3.2 (0.13)	3 (0.12)	0.5 (0.020)	18 (0.71)	230 (9.06)	76 (2.99)	62 (2.44)	13.5 (0.53)	$35_{-0.01}^0$ $(1.38_{-0.0004}^0)$	45 (1.77)	76 (2.99)	23.5 (51.8)
30A□B□B	200 (7.87)	$114.3_{-0.025}^0$ $(4.50_{-0.0010}^0)$	180 (7.09)	3.2 (0.13)	3 (0.12)	0.5 (0.020)	18 (0.71)	230 (9.06)	76 (2.99)	62 (2.44)	13.5 (0.53)	$35_{-0.01}^0$ $(1.38_{-0.0004}^0)$	45 (1.77)	76 (2.99)	28.5 (62.8)

Note The detector is a 17-bit encoder (absolute/incremental)

Cable Specifications for Servomotor Connectors

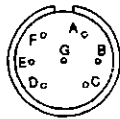

A	Phase U	E	Brake terminal
B	Phase V	F	Brake terminal
C	Phase W	G	-
D	FG (Frame ground)		-

• 4.0, 5.5 kW

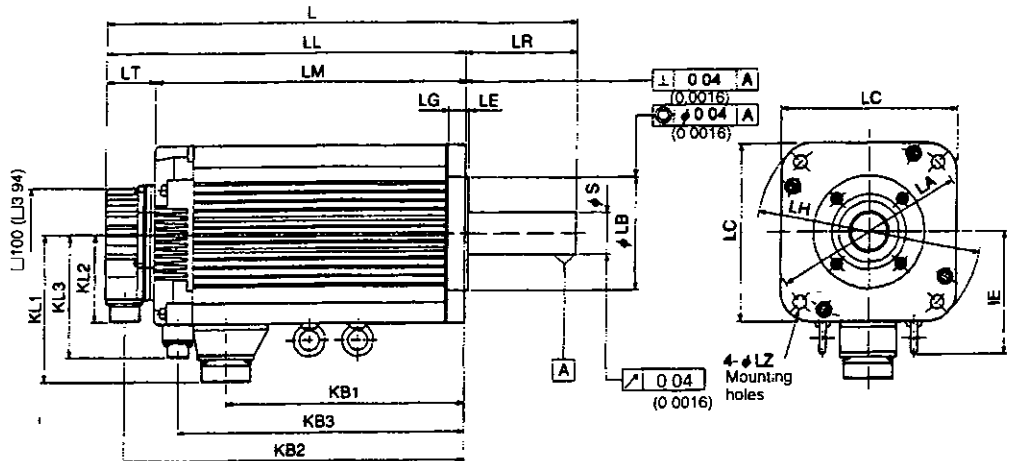

Enlarged View of Shaft End

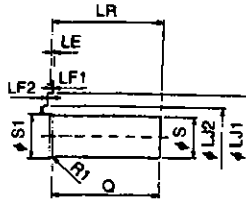

Table 4.41 Servomotors with 17-bit Encoders (Absolute/Incremental) and Brakes (SGMGH-40A□B□B, 55A□B□B, L to KL3)

Units mm (in)

Model SGMGH-	L	LL	LM	LR	LT	KB1	KB2	KB3	IE	KL1	KL2	KL3
40A□B□B	424 (16 7)	311 (12 2)	264 (10 4)	113 (4 45)	47 (1 85)	174 (6 85)	290 (11 4)	231 (9 09)	125 (4 92)	150 (5 91)	88 (3 46)	123 (4 84)
55A□B□B	498 (19 6)	385 (15 2)	338 (13 3)	113 (4 45)	47 (1 85)	248 (9 76)	364 (14 3)	305 (12)	125 (4 92)	150 (5 91)	88 (3 46)	123 (4 84)

Table 4.42 Servomotors with 17-bit Encoders (Absolute/Incremental) and Brakes (SGMGH-44A□B□B, 60A□B□B, LA to Q)

Model SGMGH-	Flange Face Dimensions mm (in)											Shaft-end Dimensions mm (in)			Approx. Mass kg (lb)
	LA	LB	LC	LE	LF1	LF2	LG	LH	LJ1	LJ2	LZ	S	S1	Q	
40A□B□B	200 (7 87)	114 ⁰ / _{3 -0.025} (4 50 -0.0010)	180 (7 09)	3 2 (0 13)	3 (0 12)	0 5 (0 02)	18 (0 71)	230 (9 06)	76 (2 99)	62 (2 44)	13 5 (0 53)	42 ⁰ / _{-0.016} (1 65 -0.0006)	45 (1 77)	110 (4 33)	35 (77 2)
55A□B□B	200 (7 87)	114 ⁰ / _{3 -0.025} (4 50 -0.0010)	180 (7 09)	3 2 (0 13)	3 (0 12)	0 5 (0 02)	18 (0 71)	230 (9 06)	76 (2 99)	62 (2 44)	13 5 (0 53)	42 ⁰ / _{-0.016} (1 65 -0.0006)	45 (1 77)	110 (4 33)	45 5 (100)

Note The detector is a 17-bit encoder (absolute/incremental)

Cable Specifications for Servomotor Connectors



A	Brake terminal
B	Brake terminal
C	-



A	Phase U
B	Phase V
C	Phase W
D	FG (Frame ground)

■ Servomotors Without Brakes and With Standard Backlash Gears for 1000 r/min

Type with Foot

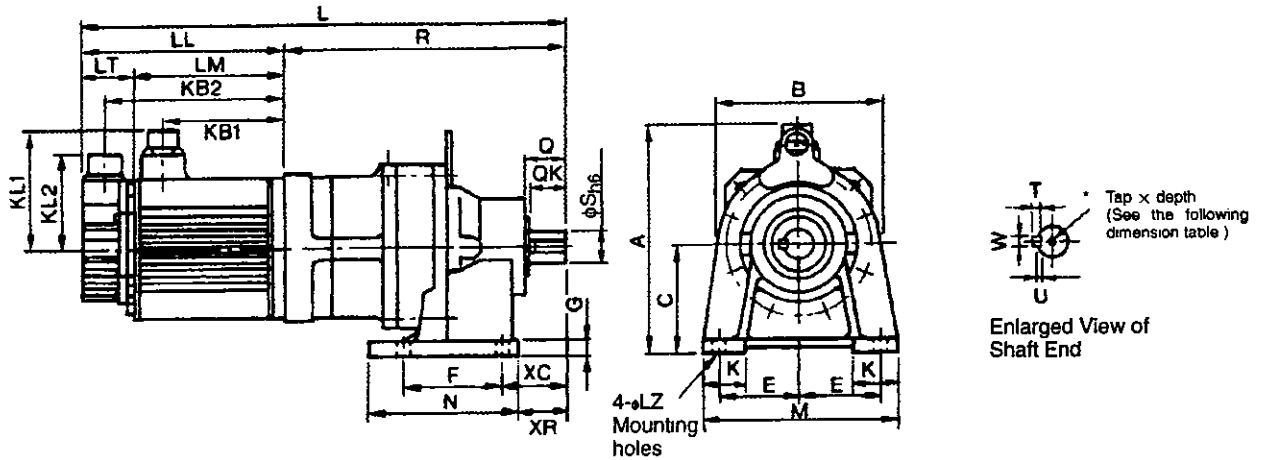

Figure 4.8 Grease Lubricating Type

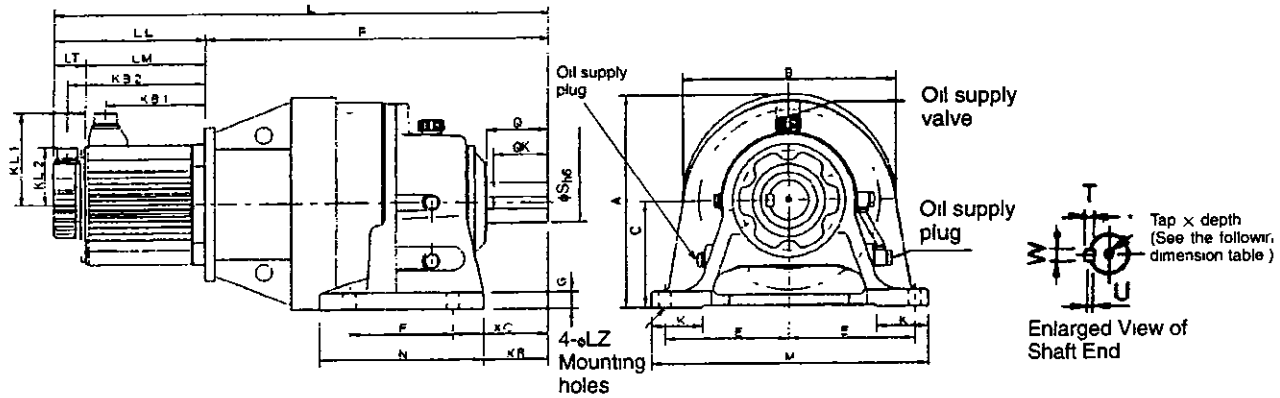

Figure 4.9 Oil Lubricating Type

Table 4.43 Servomotors Without Brakes and With Standard Backlash Gears for 1000 r/min (SGMGH-03A□BS□6 to 60A□BS□6, L to C) Units: mm (in)

Model SGMGH-	Gear Type	Gear Ratio	Fig No.	L	LL	LM	LT	KB1	KB2	KL1	KL2	R	A	B	C*	Allowable Radial Load on Center of Shaft N (lbf)
03A□BSA6	CNHX-4095	1/6	4 8	380 (14 96)	138 (5 43)	92 (3 62)	46 (1 81)	65 (2 56)	117 (4 61)	109 (4 29)	88 (3 46)	242 (9 53)	209 (8 23)	152 (5 98)	100 (3 94)	2360 (530)
03A□BSB6	CNHX-4095	1/11	4 8	380 (14 96)	138 (5 43)	92 (3 62)	46 (1 81)	65 (2 56)	117 (4 61)	109 (4 29)	88 (3 46)	242 (9 53)	209 (8 23)	152 (5 98)	100 (3 94)	2890 (649)
03A□BSC6	CNHX-4105	1/21	4 8	394 (15 51)	138 (5 43)	92 (3 62)	46 (1 81)	65 (2 56)	117 (4 61)	109 (4 29)	88 (3 46)	256 (10 08)	209 (8 23)	152 (5 98)	100 (3 94)	5390 (1210)
03A□BS76	CNHX-4105	1/29	4 8	394 (15 51)	138 (5 43)	92 (3 62)	46 (1 81)	65 (2 56)	117 (4 61)	109 (4 29)	88 (3 46)	256 (10 08)	209 (8 23)	152 (5 98)	100 (3 94)	5390 (1210)

Model SGMGH-	Gear Type	Gear Ratio	Fig No	L	LL	LM	LT	KB1	KB2	KL1	KL2	R	A	B	C*	Allowable Radial Load on Center of Shaft N (lbf)
06A□BSA6	CNHX-4105	1/6	4 8	417 (16 42)	161 (6 34)	115 (4 53)	46 (1 81)	88 (3 46)	140 (5 51)	109 (4 29)	88 (3 46)	256 (10 08)	209 (8 23)	152 (5 98)	100 (3 94)	3720 (835)
06A□BSB6	CNHX-4105	1/11	4 8	417 (16 42)	161 (6 34)	115 (4 53)	46 (1 81)	88 (3 46)	140 (5 51)	109 (4 29)	88 (3 46)	256 (10 08)	209 (8 23)	152 (5 98)	100 (3 94)	4550 (1021)
06A□BSC6	CNHX-4115	1/21	4 8	449 (17 68)	161 (6 34)	115 (4 53)	46 (1 81)	88 (3 46)	140 (5 51)	109 (4 29)	88 (3 46)	288 (11 34)	257 (10 12)	204 (8 03)	120 (4 72)	7070 (1587)
06A□BS76	CNHX-4115	1/29	4 8	449 (17 68)	161 (6 34)	115 (4 53)	46 (1 81)	88 (3 46)	140 (5 51)	109 (4 29)	88 (3 46)	288 (11 34)	257 (10 12)	204 (8 03)	120 (4 72)	7860 (1764)
09A□BSA6	CNHX-4105	1/6	4 8	441 (17 36)	185 (7 28)	139 (5 47)	46 (1 81)	112 (4 41)	164 (6 46)	109 (4 29)	88 (3 46)	256 (10 08)	209 (8 23)	152 (5 98)	100 (3 94)	3720 (835)
09A□BSB6	CNHX-4105	1/11	4 8	441 (17 36)	185 (7 28)	139 (5 47)	46 (1 81)	112 (4 41)	164 (6 46)	109 (4 29)	88 (3 46)	256 (10 08)	209 (8 23)	152 (5 98)	100 (3 94)	4550 (1021)
09A□BSC6	CNHX-4115	1/21	4 8	473 (18 62)	185 (7 28)	139 (5 47)	46 (1 81)	112 (4 41)	164 (6 46)	109 (4 29)	88 (3 46)	288 (11 34)	257 (10 12)	204 (8 03)	120 (4 72)	7070 (1587)
09A□BS76	CNHX-4115	1/29	4 8	473 (18 62)	185 (7 28)	139 (5 47)	46 (1 81)	112 (4 41)	164 (6 46)	109 (4 29)	88 (3 46)	288 (11 34)	257 (10 12)	204 (8 03)	120 (4 72)	7860 (1764)
12A□BSA6	CNHX-4115	1/6	4 8	477 (18 78)	166 (6 54)	119 (4 69)	47 (1 85)	89 (3 50)	145 (5 71)	140 (5 51)	88 (3 46)	311 (12 24)	260 (10 24)	204 (8 03)	120 (4 72)	4660 (1046)
12A□BSB6	CNHX-4115	1/11	4 8	477 (18 78)	166 (6 54)	119 (4 69)	47 (1 85)	89 (3 50)	145 (5 71)	140 (5 51)	88 (3 46)	311 (12 24)	260 (10 24)	204 (8 03)	120 (4 72)	5700 (1280)
12A□BSC6	CNHX-4130	1/21	4 8	536 (21 30)	166 (6 54)	119 (4 69)	47 (1 85)	89 (3 50)	145 (5 71)	140 (5 51)	88 (3 46)	370 (14 57)	300 (11 81)	246 (9 69)	150 (5 91)	10180 (2285)
12A□BS76	CNHX-4135	1/29	4 8	536 (21 30)	166 (6 54)	119 (4 69)	47 (1 85)	89 (3 50)	145 (5 71)	140 (5 51)	88 (3 46)	370 (14 57)	300 (11 81)	246 (9 69)	150 (5 91)	11320 (2541)
20A□BSA6	CNHX-4115	1/6	4 8	503 (19 80)	192 (7 56)	145 (5 71)	47 (1 85)	115 (4 53)	171 (6 73)	140 (5 51)	88 (3 46)	311 (12 24)	260 (10 24)	204 (8 03)	120 (4 72)	4660 (1046)
20A□BSB6	CNHX-4115	1/11	4 8	503 (19 80)	192 (7 56)	145 (5 71)	47 (1 85)	115 (4 53)	171 (6 73)	140 (5 51)	88 (3 46)	311 (12 24)	260 (10 24)	204 (8 03)	120 (4 72)	5700 (1280)
20A□BSC6	CNHX-4145	1/21	4 8	582 (22 91)	192 (7 56)	145 (5 71)	47 (1 85)	115 (4 53)	171 (6 73)	140 (5 51)	88 (3 46)	390 (15 35)	300 (11 81)	246 (9 69)	150 (5 91)	13040 (2927)
20A□BS76	CHHX-4160	1/29	4 9	687 (27 05)	192 (7 56)	145 (5 71)	47 (1 85)	115 (4 53)	171 (6 73)	140 (5 51)	88 (3 46)	495 (19 49)	319 (12 56)	318 (12 52)	160 (6 30)	18520 (4158)
30A□BSA6	CHHX-4130	1/6	4 8	596 (23 46)	226 (8 90)	179 (7 05)	47 (1 85)	149 (5 87)	205 (8 07)	140 (5 51)	88 (3 46)	370 (14 57)	300 (11 81)	246 (9 69)	150 (5 91)	6740 (1513)
30A□BSB6	CHHX-4135	1/11	4 8	596 (23 46)	226 (8 90)	179 (7 05)	47 (1 85)	149 (5 87)	205 (8 07)	140 (5 51)	88 (3 46)	370 (14 57)	300 (11 81)	246 (9 69)	150 (5 91)	8240 (1850)
30A□BSC6	CHHX-4160	1/21	4 9	721 (28 39)	226 (8 90)	179 (7 05)	47 (1 85)	149 (5 87)	205 (8 07)	140 (5 51)	88 (3 46)	495 (19 49)	319 (12 56)	318 (12 52)	160 (6 30)	16740 (3758)
30A□BS76	CHHX-4170	1/29	4 9	785 (30 91)	226 (8 90)	179 (7 05)	47 (1 85)	149 (5 87)	205 (8 07)	140 (5 51)	88 (3 46)	559 (22 01)	382 (15 04)	363 (14 29)	200 (7 87)	21770 (4887)
40A□BSA6	CHHX-4135	1/6	4 8	664 (26 1)	260 (10 2)	213 (8 39)	47 (1 85)	174 (6 85)	239 (9 41)	150 (5 91)	88 (3 46)	404 (15 9)	300 (11 8)	246 (9 69)	150 (5 91)	6740 (1513)
40A□BSB6	CHHX-4145	1/11	4 8	684 (26 9)	260 (10 2)	213 (8 39)	47 (1 85)	174 (6 85)	239 (9 41)	150 (5 91)	88 (3 46)	424 (16 7)	300 (11 8)	246 (9 69)	150 (5 91)	10740 (2411)
40A□BSC6	CHHX-4170	1/21	4 9	853 (32 6)	260 (10 2)	213 (8 39)	47 (1 85)	174 (6 85)	239 (9 41)	150 (5 91)	88 (3 46)	593 (23 3)	382 (15)	363 (14 3)	200 (7 87)	19560 (4391)
40A□BS76	CHHX-4175	1/29	4 9	853 (32 6)	260 (10 2)	213 (8 39)	47 (1 85)	174 (6 85)	239 (9 41)	150 (5 91)	88 (3 46)	593 (23 3)	382 (15)	363 (14 3)	200 (7 87)	21790 (4892)
55A□BSB6	CHHX-4160	1/11	4 9	863 (34)	334 (13 1)	287 (11 3)	47 (1 85)	248 (9 76)	313 (12 3)	150 (5 91)	88 (3 46)	529 (20 8)	319 (12 6)	318 (12 5)	160 (6 3)	13470 (3024)
55A□BSC6	CHHX-4175	1/21	4 9	927 (36 5)	334 (13 1)	287 (11 3)	47 (1 85)	248 (9 76)	313 (12 3)	150 (5 91)	88 (3 46)	593 (23 3)	382 (15)	363 (14 3)	200 (7 87)	19560 (4391)
55A□BS76	CHHX-4185	1/29	4 9	977 (38 5)	334 (13 1)	287 (11 3)	47 (1 85)	248 (9 76)	313 (12 3)	150 (5 91)	88 (3 46)	643 (25 3)	417 (16 4)	393 (15 5)	220 (8 66)	29200 (6555)



* The tolerances for all models are $\begin{matrix} 0 \\ -0.5 \end{matrix}$

Servodrive Dimensional Drawings

4 1 4 SGMGH Servomotors (1000 r/min)

Table 4.44 Servomotors Without Brakes and With Standard Backlash Gears for 1000 r/min (SGMGH-03A□BS□6 to 60A□BS□6, E to W)

Model SGMGH-	Dimensions with Foot mm (in)									Shaft-end Dimensions mm (in)						Approx Mass kg (lb)	
	E	F	G	K	M	N	XR	XC	Z	Q	QK	S	T	U	W		Tap × Depth
03A□BSA6	75 (2.95)	90 (3.54)	12 (0.47)	40 (1.57)	180 (7.09)	130 (5.12)	45 (1.77)	60 (2.36)	11 (0.43)	35 (1.38)	32 (1.26)	28 (1.10)	7 (0.28)	4 (0.16)	8 (0.31)	M8 × 19 (0.75)	20.5 (45.2)
03A□BSB6	75 (2.95)	90 (3.54)	12 (0.47)	40 (1.57)	180 (7.09)	130 (5.12)	45 (1.77)	60 (2.36)	11 (0.43)	35 (1.38)	32 (1.26)	28 (1.10)	7 (0.28)	4 (0.16)	8 (0.31)	M8 × 19 (0.75)	20.5 (45.2)
03A□BSC6	75 (2.95)	90 (3.54)	12 (0.47)	40 (1.57)	180 (7.09)	135 (5.31)	45 (1.77)	60 (2.36)	11 (0.43)	35 (1.38)	32 (1.26)	28 (1.10)	7 (0.28)	4 (0.16)	8 (0.31)	M8 × 19 (0.75)	22.5 (49.6)
03A□BS76	75 (2.95)	90 (3.54)	12 (0.47)	40 (1.57)	180 (7.09)	135 (5.31)	45 (1.77)	60 (2.36)	11 (0.43)	35 (1.38)	32 (1.26)	28 (1.10)	7 (0.28)	4 (0.16)	8 (0.31)	M8 × 19 (0.75)	22.5 (49.6)
06A□BSA6	75 (2.95)	90 (3.54)	12 (0.47)	40 (1.57)	180 (7.09)	135 (5.31)	45 (1.77)	60 (2.36)	11 (0.43)	35 (1.38)	32 (1.26)	28 (1.10)	7 (0.28)	4 (0.16)	8 (0.31)	M8 × 19 (0.75)	24.6 (54.2)
06A□BSB6	75 (2.95)	90 (3.54)	12 (0.47)	40 (1.57)	180 (7.09)	135 (5.31)	45 (1.77)	60 (2.36)	11 (0.43)	35 (1.38)	32 (1.26)	28 (1.10)	7 (0.28)	4 (0.16)	8 (0.31)	M8 × 19 (0.75)	24.6 (54.2)
06A□BSC6	95 (3.74)	115 (4.53)	15 (0.59)	55 (2.17)	230 (9.06)	155 (6.10)	62 (2.44)	82 (3.23)	14 (0.55)	55 (2.17)	50 (1.97)	38 (1.50)	8 (0.31)	5 (0.20)	10 (0.39)	M10 × 22 (0.87)	34.6 (76.3)
06A□BS76	95 (3.74)	115 (4.53)	15 (0.59)	55 (2.17)	230 (9.06)	155 (6.10)	62 (2.44)	82 (3.23)	14 (0.55)	55 (2.17)	50 (1.97)	38 (1.50)	8 (0.31)	5 (0.20)	10 (0.39)	M10 × 22 (0.87)	34.6 (76.3)
09A□BSA6	75 (2.95)	90 (3.54)	12 (0.47)	40 (1.57)	180 (7.09)	135 (5.31)	45 (1.77)	60 (2.36)	11 (0.43)	35 (1.38)	32 (1.26)	28 (1.10)	7 (0.28)	4 (0.16)	8 (0.31)	M8 × 19 (0.75)	26.6 (58.6)
09A□BSB6	75 (2.95)	90 (3.54)	12 (0.47)	40 (1.57)	180 (7.09)	135 (5.31)	45 (1.77)	60 (2.36)	11 (0.43)	35 (1.38)	32 (1.26)	28 (1.10)	7 (0.28)	4 (0.16)	8 (0.31)	M8 × 19 (0.75)	26.6 (58.6)
09A□BSC6	95 (3.74)	115 (4.53)	15 (0.59)	55 (2.17)	230 (9.06)	155 (6.10)	62 (2.44)	82 (3.23)	14 (0.55)	55 (2.17)	50 (1.97)	38 (1.50)	8 (0.31)	5 (0.20)	10 (0.39)	M10 × 22 (0.87)	36.6 (80.7)
09A□BS76	95 (3.74)	115 (4.53)	15 (0.59)	55 (2.17)	230 (9.06)	155 (6.10)	62 (2.44)	82 (3.23)	14 (0.55)	55 (2.17)	50 (1.97)	38 (1.50)	8 (0.31)	5 (0.20)	10 (0.39)	M10 × 22 (0.87)	36.6 (80.7)
12A□BSA6	95 (3.74)	115 (4.53)	15 (0.59)	55 (2.17)	230 (9.06)	155 (6.10)	62 (2.44)	82 (3.23)	14 (0.55)	55 (2.17)	50 (1.97)	38 (1.50)	8 (0.31)	5 (0.20)	10 (0.39)	M10 × 22 (0.87)	43 (94.8)
12A□BSB6	95 (3.74)	115 (4.53)	15 (0.59)	55 (2.17)	230 (9.06)	155 (6.10)	62 (2.44)	82 (3.23)	14 (0.55)	55 (2.17)	50 (1.97)	38 (1.50)	8 (0.31)	5 (0.20)	10 (0.39)	M10 × 22 (0.87)	43 (94.8)
12A□BSC6	145 (5.71)	145 (5.71)	22 (0.87)	65 (2.56)	330 (12.99)	195 (7.68)	75 (2.95)	100 (3.94)	18 (0.71)	70 (2.76)	56 (2.20)	50 (1.97)	9 (0.35)	5.5 (0.22)	14 (0.55)	M10 × 18 (0.71)	67 (147.7)
12A□BS76	145 (5.71)	145 (5.71)	22 (0.87)	65 (2.56)	330 (12.99)	195 (7.68)	75 (2.95)	100 (3.94)	18 (0.71)	70 (2.76)	56 (2.20)	50 (1.97)	9 (0.35)	5.5 (0.22)	14 (0.55)	M10 × 18 (0.71)	67 (147.7)
20A□BSA6	95 (3.74)	115 (4.53)	15 (0.59)	55 (2.17)	230 (9.06)	155 (6.10)	62 (2.44)	82 (3.23)	14 (0.55)	55 (2.17)	50 (1.97)	38 (1.50)	8 (0.31)	5 (0.20)	10 (0.39)	M10 × 22 (0.87)	47 (103.6)
20A□BSB6	95 (3.74)	115 (4.53)	15 (0.59)	55 (2.17)	230 (9.06)	155 (6.10)	62 (2.44)	82 (3.23)	14 (0.55)	55 (2.17)	50 (1.97)	38 (1.50)	8 (0.31)	5 (0.20)	10 (0.39)	M10 × 22 (0.87)	47 (103.6)
20A□BSC6	145 (5.71)	145 (5.71)	22 (0.87)	65 (2.56)	330 (12.99)	195 (7.68)	75 (2.95)	100 (3.94)	18 (0.71)	70 (2.76)	56 (2.20)	50 (1.97)	9 (0.35)	5.5 (0.22)	14 (0.55)	M10 × 18 (0.71)	72 (158.7)
20A□BS76	185 (7.28)	150 (5.91)	25 (0.98)	75 (2.95)	410 (16.14)	238 (9.37)	95 (3.74)	139 (5.47)	18 (0.71)	90 (3.54)	80 (3.15)	60 (2.36)	11 (0.43)	7 (0.28)	18 (0.71)	M10 × 18 (0.71)	126 (278)
30A□BSA6	145 (5.71)	145 (5.71)	22 (0.87)	65 (2.56)	330 (12.99)	195 (7.68)	75 (2.95)	100 (3.94)	18 (0.71)	70 (2.76)	56 (2.20)	50 (1.97)	9 (0.35)	5.5 (0.22)	14 (0.55)	M10 × 18 (0.71)	76 (167.6)
30A□BSB6	145 (5.71)	145 (5.71)	22 (0.87)	65 (2.56)	330 (12.99)	195 (7.68)	75 (2.95)	100 (3.94)	18 (0.71)	70 (2.76)	56 (2.20)	50 (1.97)	9 (0.35)	5.5 (0.22)	14 (0.55)	M10 × 18 (0.71)	76 (167.6)
30A□BSC6	185 (7.28)	150 (5.91)	25 (0.98)	75 (2.95)	410 (16.14)	238 (9.37)	95 (3.74)	139 (5.47)	18 (0.71)	90 (3.54)	80 (3.15)	60 (2.36)	11 (0.43)	7 (0.28)	18 (0.71)	M10 × 18 (0.71)	131 (289)
30A□BS76	190 (7.48)	275 (10.83)	30 (1.18)	80 (3.15)	430 (16.93)	335 (13.19)	95 (3.74)	125 (4.92)	22 (0.87)	90 (3.54)	80 (3.15)	70 (2.76)	12 (0.47)	7.5 (0.30)	20 (0.79)	M12 × 24 (0.94)	176 (388)
40A□BSA6	145 (5.71)	145 (5.71)	22 (0.87)	65 (2.56)	330 (13)	195 (7.68)	75 (2.95)	100 (3.94)	18 (0.71)	70 (2.76)	56 (2.2)	50 (1.97)	9 (0.35)	5.5 (0.22)	14 (0.55)	M10 × 18 (0.71)	88 (194)
40A□BSB6	145 (5.71)	145 (5.71)	22 (0.87)	65 (2.56)	330 (13)	195 (7.68)	75 (2.95)	100 (3.94)	18 (0.71)	70 (2.76)	56 (2.20)	50 (1.97)	9 (0.35)	5.5 (0.22)	14 (0.55)	M10 × 18 (0.71)	89 (196)
40A□BSC6	190 (7.48)	275 (10.8)	30 (1.18)	80 (3.15)	430 (16.9)	335 (13.2)	95 (3.74)	125 (4.92)	22 (0.87)	90 (3.54)	80 (3.15)	70 (2.76)	12 (0.47)	7.5 (0.30)	20 (0.79)	M12 × 24 (0.94)	191 (421)
40A□BS76	190 (7.48)	275 (10.8)	30 (1.18)	80 (3.15)	430 (16.9)	335 (13.2)	95 (3.74)	125 (4.92)	22 (0.87)	90 (3.54)	80 (3.15)	70 (2.76)	12 (0.47)	7.5 (0.30)	20 (0.79)	M12 × 24 (0.94)	191 (421)
55A□BSB6	185 (7.28)	150 (5.91)	25 (0.98)	75 (2.95)	410 (16.1)	238 (9.37)	95 (3.74)	139 (5.47)	18 (0.71)	90 (3.54)	80 (3.15)	60 (2.36)	11 (0.43)	7 (0.28)	18 (0.71)	M10 × 18 (0.71)	155 (342)

Model SGMGH-	Dimensions with Foot mm (in)									Shaft-end Dimensions mm (in)						Approx Mass kg (lb)	
	E	F	G	K	M	N	XR	XC	Z	Q	QK	S	T	U	W		Tap × Depth
55A□BSC6	190 (7.48)	275 (10.8)	30 (1.18)	80 (3.15)	430 (16.9)	335 (13.2)	95 (3.74)	125 (4.92)	22 (0.87)	90 (3.54)	80 (3.15)	70 (2.76)	12 (0.47)	75 (0.30)	20 (0.79)	M12 × 24 (0.94)	201 (443)
55A□BS76	210 (8.27)	320 (12.6)	30 (1.18)	85 (3.35)	470 (18.5)	380 (15)	115 (4.53)	145 (5.71)	22 (0.87)	110 (4.33)	100 (3.94)	80 (3.15)	14 (0.55)	9 (0.35)	22 (0.87)	M12 × 24 (0.94)	245 (540)

• Dimensional Tolerances

Model SGMGH-	Shaft-end Dimensions mm (in)	
	S	
03A□BSA6	28 ⁰ _{-0.013}	(1.11 ⁰ _{-0.0005})
03A□BSB6	28 ⁰ _{-0.013}	(1.11 ⁰ _{-0.0005})
03A□BSC6	28 ⁰ _{-0.013}	(1.11 ⁰ _{-0.0005})
03A□BS76	28 ⁰ _{-0.013}	(1.11 ⁰ _{-0.0005})
06A□BSA6	28 ⁰ _{-0.013}	(1.11 ⁰ _{-0.0005})
06A□BSB6	28 ⁰ _{-0.013}	(1.11 ⁰ _{-0.0005})
06A□BSC6	38 ⁰ _{-0.016}	(1.51 ⁰ _{-0.0006})
06A□BS76	38 ⁰ _{-0.016}	(1.51 ⁰ _{-0.0006})
09A□BSA6	28 ⁰ _{-0.013}	(1.11 ⁰ _{-0.0005})
09A□BSB6	28 ⁰ _{-0.013}	(1.11 ⁰ _{-0.0005})
09A□BSC6	38 ⁰ _{-0.016}	(1.51 ⁰ _{-0.0006})
09A□BS76	38 ⁰ _{-0.016}	(1.51 ⁰ _{-0.0006})
12A□BSA6	38 ⁰ _{-0.016}	(1.51 ⁰ _{-0.0006})
12A□BSB6	38 ⁰ _{-0.016}	(1.51 ⁰ _{-0.0006})
12A□BSC6	50 ⁰ _{-0.016}	(1.98 ⁰ _{-0.0006})
12A□BS76	50 ⁰ _{-0.016}	(1.98 ⁰ _{-0.0006})
20A□BSA6	38 ⁰ _{-0.016}	(1.51 ⁰ _{-0.0006})
20A□BSB6	38 ⁰ _{-0.016}	(1.51 ⁰ _{-0.0006})
20A□BSC6	50 ⁰ _{-0.016}	(1.98 ⁰ _{-0.0006})
20A□BS76	60 ⁰ _{-0.019}	(2.38 ⁰ _{-0.0008})
30A□BSA6	50 ⁰ _{-0.016}	(1.98 ⁰ _{-0.0006})
30A□BSB6	50 ⁰ _{-0.016}	(1.98 ⁰ _{-0.0006})
30A□BSC6	60 ⁰ _{-0.019}	(2.38 ⁰ _{-0.0008})
30A□BS76	70 ⁰ _{-0.019}	(2.78 ⁰ _{-0.0008})
40A□BSA6	50 ⁰ _{-0.016}	(1.98 ⁰ _{-0.0006})



Servodrive Dimensional Drawings

4 1 4 SGMGH Servomotors (1000 r/min)

Model SGMGH-	Shaft-end Dimensions mm (in)	
	S	
40A□BSB6	$50 \begin{matrix} 0 \\ - 0.016 \end{matrix}$	$\left(1.98 \begin{matrix} 0 \\ - 0.0006 \end{matrix} \right)$
40A□BSC6	$70 \begin{matrix} 0 \\ - 0.019 \end{matrix}$	$\left(2.78 \begin{matrix} 0 \\ - 0.0008 \end{matrix} \right)$
40A□BS76	$70 \begin{matrix} 0 \\ - 0.019 \end{matrix}$	$\left(2.78 \begin{matrix} 0 \\ - 0.0008 \end{matrix} \right)$
55A□BSB6	$60 \begin{matrix} 0 \\ - 0.019 \end{matrix}$	$\left(2.38 \begin{matrix} 0 \\ - 0.0008 \end{matrix} \right)$
55A□BSC6	$70 \begin{matrix} 0 \\ - 0.019 \end{matrix}$	$\left(2.78 \begin{matrix} 0 \\ - 0.0008 \end{matrix} \right)$
55A□BS76	$80 \begin{matrix} 0 \\ - 0.022 \end{matrix}$	$\left(3.1 \begin{matrix} 0 \\ - 0.0007 \end{matrix} \right)$

Flange Type

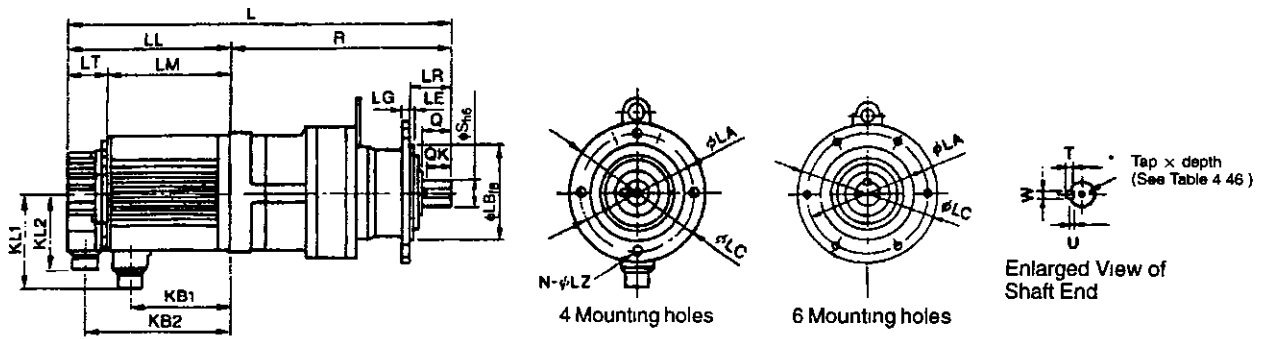

Figure 4.10 Grease Lubricating Type

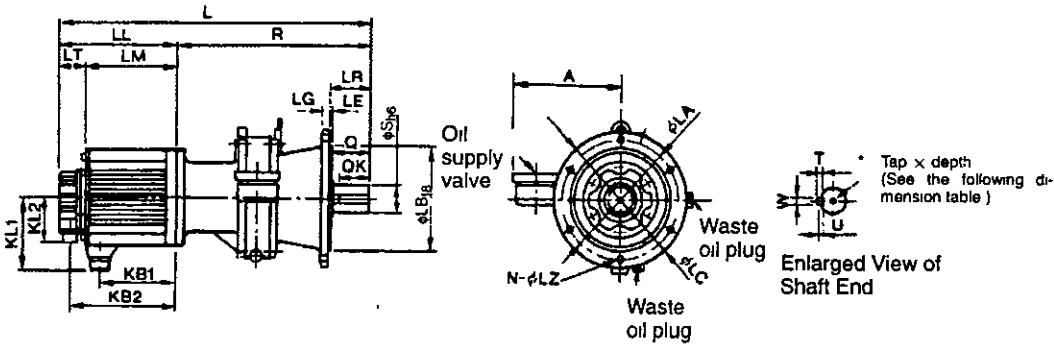

Figure 4.11 Smaller Oil Lubricating Type

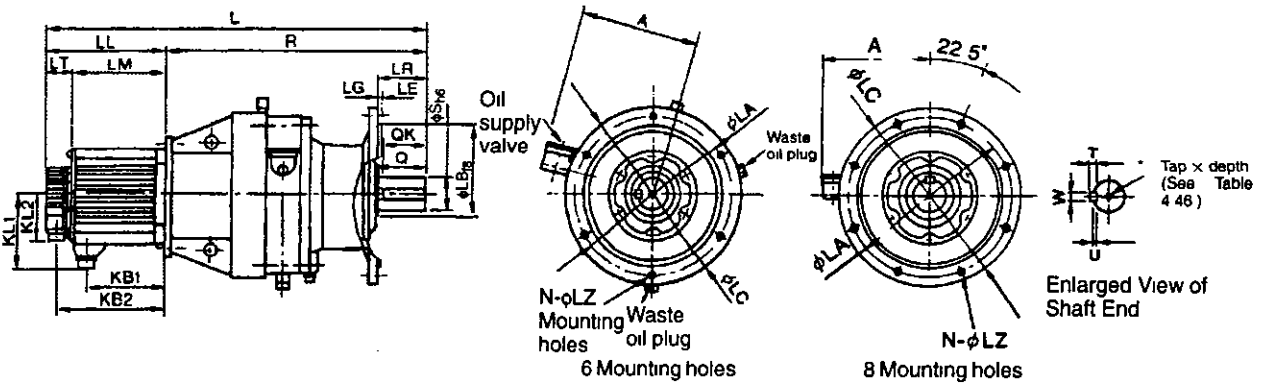

Figure 4.12 Larger Oil Lubricating Type

Servodrive Dimensional Drawings

4 1 4 SGMGH Servomotors (1000 r/min)

Table 4.45 Servomotors Without Brakes and With Standard Backlash Gears
1000 r/min (SGMGH-03A□BT□6 to 60A□BT□6, L to A) Units mm

Model SGMGH-	Gear Type	Gear Ratio	Fig No	L	LL	LM	LT	KB1	KB2	KL1	KL2	R	A	Allowa Load c Center Shaft (lbf)
03A□BTA6	CNVX-4095	1/6	4 10	380 (14 96)	138 (5 43)	92 (3 62)	46 (1 81)	65 (2 56)	117 (4 61)	109 (4 29)	88 (3 46)	242 (9 53)	-	2360 (530)
03A□BTB6	CNVX-4095	1/11	4 10	380 (14 96)	138 (5 43)	92 (3 62)	46 (1 81)	65 (2 56)	117 (4 61)	109 (4 29)	88 (3 46)	242 (9 53)	-	2890 (649)
03A□BTC6	CNVX-4105	1/21	4 10	394 (15 51)	138 (5 43)	92 (3 62)	46 (1 81)	65 (2 56)	117 (4 61)	109 (4 29)	88 (3 46)	256 (10 08)	-	5190 (1210)
03A□BT76	CNVX-4105	1/29	4 10	394 (15 51)	138 (5 43)	92 (3 62)	46 (1 81)	65 (2 56)	117 (4 61)	109 (4 29)	88 (3 46)	256 (10 08)	-	5390 (1210)
06A□BTA6	CNVX-4105	1/6	4 10	417 (16 42)	161 (6 34)	115 (4 53)	46 (1 81)	88 (3 46)	140 (5 51)	109 (4 29)	88 (3 46)	256 (10 08)	-	3720 (835)
06A□BTB6	CNVX-4105	1/11	4 10	417 (16 42)	161 (6 34)	115 (4 53)	46 (1 81)	88 (3 46)	140 (5 51)	109 (4 29)	88 (3 46)	256 (10 08)	-	4550 (1021)
06A□BTC6	CNVX-4115	1/21	4 10	449 (17 68)	161 (6 34)	115 (4 53)	46 (1 81)	88 (3 46)	140 (5 51)	109 (4 29)	88 (3 46)	288 (11 34)	-	7070 (1587)
06A□BT76	CNVX-4115	1/29	4 10	449 (17 68)	161 (6 34)	115 (4 53)	46 (1 81)	88 (3 46)	140 (5 51)	109 (4 29)	88 (3 46)	288 (11 34)	-	7860 (176)
09A□BTA6	CNVX-4105	1/6	4 10	441 (17 36)	185 (7 28)	139 (5 47)	46 (1 81)	112 (4 41)	164 (6 46)	109 (4 29)	88 (3 46)	256 (10 08)	-	3720 (835)
09A□BTB6	CNVX-4105	1/11	4 10	441 (17 36)	185 (7 28)	139 (5 47)	46 (1 81)	112 (4 41)	164 (6 46)	109 (4 29)	88 (3 46)	256 (10 08)	-	4550 (1021)
09A□BTC6	CNVX-4115	1/21	4 10	473 (18 62)	185 (7 28)	139 (5 47)	46 (1 81)	112 (4 41)	164 (6 46)	109 (4 29)	88 (3 46)	288 (11 34)	-	7070 (1587)
09A□BT76	CNVX-4115	1/29	4 10	473 (18 62)	185 (7 28)	139 (5 47)	46 (1 81)	112 (4 41)	164 (6 46)	109 (4 29)	88 (3 46)	288 (11 34)	-	7860 (176)
12A□BTA6	CNVX-4115	1/6	4 10	477 (18 78)	166 (6 54)	119 (4 69)	47 (1 85)	89 (3 50)	145 (5 71)	140 (5 51)	88 (3 46)	311 (12 24)	-	4660 (1046)
12A□BTB6	CNVX-4115	1/11	4 10	477 (18 78)	166 (6 54)	119 (4 69)	47 (1 85)	89 (3 50)	145 (5 71)	140 (5 51)	88 (3 46)	311 (12 24)	-	5700 (1280)
12A□BTC6	CHVX-4130	1/21	4 11	536 (21 10)	166 (6 54)	119 (4 69)	47 (1 85)	89 (3 50)	145 (5 71)	140 (5 51)	88 (3 46)	370 (14 57)	209 (8 23)	10180 (2285)
12A□BT76	CHVX-4135	1/29	4 11	536 (21 10)	166 (6 54)	119 (4 69)	47 (1 85)	89 (3 50)	145 (5 71)	140 (5 51)	88 (3 46)	370 (14 57)	209 (8 23)	11320 (2541)
20A□BTA6	CNVX-4115	1/6	4 10	503 (19 80)	192 (7 56)	145 (5 71)	47 (1 85)	115 (4 53)	171 (6 73)	140 (5 51)	88 (3 46)	311 (12 24)	-	4660 (1046)
20A□BTB6	CNVX-4115	1/11	4 10	503 (19 80)	192 (7 56)	145 (5 71)	47 (1 85)	115 (4 53)	171 (6 73)	140 (5 51)	88 (3 46)	311 (12 24)	-	5700 (1280)
20A□BTC6	CNVX-4145	1/21	4 11	582 (22 91)	192 (7 56)	145 (5 71)	47 (1 85)	115 (4 53)	171 (6 73)	140 (5 51)	88 (3 46)	390 (15 35)	209 (8 23)	17040 (3927)
20A□BT76	CHVJ-4160	1/29	4 12	687 (27 05)	192 (7 56)	145 (5 71)	47 (1 85)	115 (4 53)	171 (6 73)	140 (5 51)	88 (3 46)	495 (19 49)	228 (8 98)	18520 (4158)
30A□BTA6	CHVX-4130	1/6	4 11	596 (23 46)	226 (8 90)	179 (7 05)	47 (1 85)	149 (5 87)	205 (8 07)	140 (5 51)	88 (3 46)	370 (14 57)	209 (8 23)	6740 (1513)
30A□BTB6	CHVX-4135	1/11	4 11	596 (23 46)	226 (8 90)	179 (7 05)	47 (1 85)	149 (5 87)	205 (8 07)	140 (5 51)	88 (3 46)	370 (14 57)	209 (8 23)	8240 (1850)
30A□BTC6	CHVJ-4160	1/21	4 12	721 (28 39)	226 (8 90)	179 (7 05)	47 (1 85)	149 (5 87)	205 (8 07)	140 (5 51)	88 (3 46)	495 (19 49)	228 (8 98)	16740 (3758)
30A□BT76	CHVJ-4170	1/29	4 12	785 (30 91)	226 (8 90)	179 (7 05)	47 (1 85)	149 (5 87)	205 (8 07)	140 (5 51)	88 (3 46)	559 (22 01)	243 (9 57)	21770 (4887)
40A□BTA6	CHVX-4135	1/6	4 11	664 (26 1)	260 (10 2)	213 (8 39)	47 (1 85)	174 (6 85)	239 (9 41)	150 (5 91)	88 (3 46)	404 (15 9)	209 (8 23)	6740 (1513)
40A□BTB6	CHVX-4145	1/11	4 11	684 (26 9)	260 (10 2)	213 (8 39)	47 (1 85)	174 (6 85)	239 (9 41)	150 (5 91)	88 (3 46)	424 (16 7)	209 (8 23)	10740 (2411)
40A□BTC6	CHVJ-4170	1/21	4 12	853 (33 6)	260 (10 2)	213 (8 39)	47 (1 85)	174 (6 85)	239 (9 41)	150 (5 91)	88 (3 46)	593 (23 3)	243 (9 57)	19560 (4391)
40A□BT76	CHVJ-4175	1/29	4 12	853 (33 6)	260 (10 2)	213 (8 39)	47 (1 85)	174 (6 85)	239 (9 41)	150 (5 91)	88 (3 46)	593 (23 3)	243 (9 57)	21790 (4892)
55A□BTB6	CHVJ-4160	1/11	4 12	863 (34)	334 (13 1)	287 (11 3)	47 (1 85)	248 (9 76)	313 (12 3)	150 (5 91)	88 (3 46)	529 (20 8)	228 (8 98)	13470 (3024)

Model SGMGH-	Gear Type	Gear Ratio	Fig No	L	LL	LM	LT	KB1	KB2	KL1	KL2	R	A	Allowable Radial Load on Center of Shaft N (lbf)
55A□BTC6	CHVJ-4175	1/21	4 12	927 (36 5)	334 (13 1)	287 (11 3)	47 (1 85)	248 (9 76)	313 (12 3)	150 (5 91)	88 (3 46)	592 (23 3)	243 (9 57)	19560 (4391)
55A□BT76	CHVJ-4185	1/29	4 12	977 (38 5)	334 (13 1)	287 (11 3)	47 (1 85)	248 (9 76)	313 (12 3)	150 (5 91)	88 (3 46)	643 (25 3)	258 (10 2)	29200 (6558)

Table 4.46 Servomotors Without Brakes and With Standard Backlash Gears for 1000 r/min (SGMGH-03A□BT□6 to 60A□BT□6, LA to W)

Model SGMGH-	Flange Face Dimensions mm (in)								Shaft-end Dimensions mm (in)							Approx Mass kg (lb)
	LA	LB	LC	LE	LG	LR	N	LZ	Q	QK	S	T	U	W	Tap × Depth	
03A□BTA6	134 (5 28)	110 (4 33)	160 (6 30)	3 (0 12)	9 (0 35)	48 (1 89)	4 (0 16)	11 (0 43)	35 (1 38)	32 (1 26)	28 (1 10)	7 (0 28)	4 (0 16)	8 (0 31)	M8 × 19 (0 75)	18 5 (40 8)
03A□BTB6	134 (5 28)	110 (4 33)	160 (6 30)	3 (0 12)	9 (0 35)	48 (1 89)	4 (0 16)	11 (0 43)	35 (1 38)	32 (1 26)	28 (1 10)	7 (0 28)	4 (0 16)	8 (0 31)	M8 × 19 (0 75)	18 5 (40 8)
03A□BTC6	134 (5 28)	110 (4 33)	160 (6 30)	3 (0 12)	9 (0 35)	48 (1 89)	4 (0 16)	11 (0 43)	35 (1 38)	32 (1 26)	28 (1 10)	7 (0 28)	4 (0 16)	8 (0 31)	M8 × 19 (0 75)	20 5 (45 2)
03A□BT76	134 (5 28)	110 (4 33)	160 (6 30)	3 (0 12)	9 (0 35)	48 (1 89)	4 (0 16)	11 (0 43)	35 (1 38)	32 (1 26)	28 (1 10)	7 (0 28)	4 (0 16)	8 (0 31)	M8 × 19 (0 75)	20 5 (45 2)
06A□BTA6	134 (5 28)	110 (4 33)	160 (6 30)	3 (0 12)	9 (0 35)	48 (1 89)	4 (0 16)	11 (0 43)	35 (1 38)	32 (1 26)	28 (1 10)	7 (0 28)	4 (0 16)	8 (0 31)	M8 × 19 (0 75)	22 6 (49 8)
06A□BTB6	134 (5 28)	110 (4 33)	160 (6 30)	3 (0 12)	9 (0 35)	48 (1 89)	4 (0 16)	11 (0 43)	35 (1 38)	32 (1 26)	28 (1 10)	7 (0 28)	4 (0 16)	8 (0 31)	M8 × 19 (0 75)	22 6 (49 8)
06A□BTC6	180 (7 09)	140 (5 51)	210 (8 27)	4 (0 16)	13 (0 51)	69 (2 72)	6 (0 24)	11 (0 43)	55 (2 17)	50 (1 97)	38 (1 50)	8 (0 31)	5 (0 20)	10 (0 39)	M10 × 22 (0 87)	33 6 (74 1)
06A□BT76	180 (7 09)	140 (5 51)	210 (8 27)	4 (0 16)	13 (0 51)	69 (2 72)	6 (0 24)	11 (0 43)	55 (2 17)	50 (1 97)	38 (1 50)	8 (0 31)	5 (0 20)	10 (0 39)	M10 × 22 (0 87)	33 6 (74 1)
09A□BTA6	134 (5 28)	110 (4 33)	160 (6 30)	3 (0 12)	9 (0 35)	48 (1 89)	4 (0 16)	11 (0 43)	35 (1 38)	32 (1 26)	28 (1 10)	7 (0 28)	4 (0 16)	8 (0 31)	M8 × 19 (0 75)	24 6 (54 2)
09A□BTB6	134 (5 28)	110 (4 33)	160 (6 30)	3 (0 12)	9 (0 35)	48 (1 89)	4 (0 16)	11 (0 43)	35 (1 38)	32 (1 26)	28 (1 10)	7 (0 28)	4 (0 16)	8 (0 31)	M8 × 19 (0 75)	24 6 (54 2)
09A□BTC6	180 (7 09)	140 (5 51)	210 (8 27)	4 (0 16)	13 (0 51)	69 (2 72)	6 (0 24)	11 (0 43)	55 (2 17)	50 (1 97)	38 (1 50)	8 (0 31)	5 (0 20)	10 (0 39)	M10 × 22 (0 87)	35 6 (78 5)
09A□BT76	180 (7 09)	140 (5 51)	210 (8 27)	4 (0 16)	13 (0 51)	69 (2 72)	6 (0 24)	11 (0 43)	55 (2 17)	50 (1 97)	38 (1 50)	8 (0 31)	5 (0 20)	10 (0 39)	M10 × 22 (0 87)	35 6 (78 5)
12A□BTA6	180 (7 09)	140 (5 51)	210 (8 27)	4 (0 16)	13 (0 51)	69 (2 72)	6 (0 24)	11 (0 43)	55 (2 17)	50 (1 97)	38 (1 50)	8 (0 31)	5 (0 20)	10 (0 39)	M10 × 22 (0 87)	42 (92 6)
12A□BTB6	180 (7 09)	140 (5 51)	210 (8 27)	4 (0 16)	13 (0 51)	69 (2 72)	6 (0 24)	11 (0 43)	55 (2 17)	50 (1 97)	38 (1 50)	8 (0 31)	5 (0 20)	10 (0 39)	M10 × 22 (0 87)	42 (92 6)
12A□BTC6	230 (9 06)	200 (7 87)	260 (10 24)	4 (0 16)	15 (0 59)	76 (2 99)	6 (0 24)	11 (0 43)	70 (2 76)	56 (2 20)	50 (1 97)	9 (0 35)	5 5 (0 22)	14 (0 55)	M10 × 18 (0 71)	66 (145 5)
12A□BT76	230 (9 06)	200 (7 87)	260 (10 24)	4 (0 16)	15 (0 59)	76 (2 99)	6 (0 24)	11 (0 43)	70 (2 76)	56 (2 20)	50 (1 97)	9 (0 35)	5 5 (0 22)	14 (0 55)	M10 × 18 (0 71)	66 (145 5)
20A□BTA6	180 (7 09)	140 (5 51)	210 (8 27)	4 (0 16)	13 (0 51)	69 (2 72)	6 (0 24)	11 (0 43)	55 (2 17)	50 (1 97)	38 (1 50)	8 (0 31)	5 (0 20)	10 (0 39)	M10 × 22 (0 87)	46 (101 4)
20A□BTB6	180 (7 09)	140 (5 51)	210 (8 27)	4 (0 16)	13 (0 51)	69 (2 72)	6 (0 24)	11 (0 43)	55 (2 17)	50 (1 97)	38 (1 50)	8 (0 31)	5 (0 20)	10 (0 39)	M10 × 22 (0 87)	46 (101 4)
20A□BTC6	230 (9 06)	200 (7 87)	260 (10 24)	4 (0 16)	15 (0 59)	96 (3 78)	6 (0 24)	11 (0 43)	90 (3 54)	80 (3 15)	50 (1 97)	9 (0 35)	5 5 (0 22)	14 (0 55)	M10 × 18 (0 71)	71 (156 5)
20A□BT76	310 (12 20)	270 (10 63)	340 (13 39)	4 (0 16)	20 (0 79)	89 (3 50)	6 (0 24)	11 (0 43)	90 (3 54)	80 (3 15)	60 (2 36)	11 (0 43)	7 (0 28)	18 (0 71)	M10 × 18 (0 71)	121 (267)
30A□BTA6	230 (9 06)	200 (7 87)	260 (10 24)	4 (0 16)	15 (0 59)	76 (2 99)	6 (0 24)	11 (0 43)	70 (2 76)	56 (2 20)	50 (1 97)	9 (0 35)	5 5 (0 22)	14 (0 55)	M10 × 18 (0 71)	75 (165 3)
30A□BTB6	230 (9 06)	200 (7 87)	260 (10 24)	4 (0 16)	15 (0 59)	76 (2 99)	6 (0 24)	11 (0 43)	70 (2 76)	56 (2 20)	50 (1 97)	9 (0 35)	5 5 (0 22)	14 (0 55)	M10 × 18 (0 71)	75 (165 3)
30A□BTC6	310 (12 20)	270 (10 63)	340 (13 39)	4 (0 16)	20 (0 79)	89 (3 50)	6 (0 24)	11 (0 43)	90 (3 54)	80 (3 15)	60 (2 36)	11 (0 43)	7 (0 28)	18 (0 71)	M10 × 18 (0 71)	126 (278)
30A□BT76	360 (14 17)	316 (12 44)	400 (15 75)	5 (0 20)	22 (0 87)	94 (3 70)	8 (0 31)	14 (0 55)	90 (3 54)	80 (3 15)	70 (2 76)	12 (0 47)	7 5 (0 30)	20 (0 79)	M12 × 24 (0 94)	176 (388)
40A□BTA6	230 (9 06)	200 (7 87)	260 (10 2)	4 (0 16)	15 (0 59)	76 (2 99)	6 (0 24)	11 (0 43)	70 (2 76)	56 (2 20)	50 (1 97)	9 (0 35)	5 5 (0 22)	14 (0 55)	M10 × 18 (0 71)	87 (192)
40A□BTB6	230 (9 06)	200 (7 87)	260 (10 2)	4 (0 16)	15 (0 59)	96 (3 78)	6 (0 24)	11 (0 43)	90 (3 54)	80 (3 15)	50 (1 97)	9 (0 35)	5 5 (0 22)	14 (0 55)	M10 × 18 (0 71)	88 (194)

Servodrive Dimensional Drawings

4.1.4 SGMGH Servomotors (1000 r/min)

Model SGMGH-	Flange Face Dimensions mm (in)							Shaft-end Dimensions mm (in)							Approx Mass kg (lb)	
	LA	LB	LC	LE	LG	LR	N	LZ	Q	QK	S	T	U	W		Tap × Depth
40A□BTC6	360 (14.2)	316 (12.4)	400 (15.7)	5 (0.2)	22 (0.87)	94 (3.7)	8 (0.31)	14 (0.55)	90 (3.54)	80 (3.15)	70 (2.76)	12 (0.47)	7.5 (0.3)	20 (0.79)	M12 × 24 (0.94)	191 (421)
40A□BT76	360 (14.2)	316 (12.4)	400 (15.7)	5 (0.2)	22 (0.87)	94 (3.7)	8 (0.31)	14 (0.55)	90 (3.54)	80 (3.15)	70 (2.76)	12 (0.47)	7.5 (0.3)	20 (0.79)	M12 × 24 (0.94)	191 (421)
55A□BTB6	310 (12.2)	270 (10.6)	340 (13.4)	4 (0.16)	20 (0.79)	89 (3.5)	6 (0.24)	11 (0.43)	90 (3.54)	80 (3.15)	60 (2.32)	11 (0.43)	5 (0.2)	18 (0.71)	M10 × 18 (0.71)	150 (331)
55A□BTC6	360 (14.2)	316 (12.4)	400 (15.7)	5 (0.2)	22 (0.87)	94 (3.7)	8 (0.31)	14 (0.55)	90 (3.54)	80 (3.15)	70 (2.76)	12 (0.47)	7.5 (0.3)	20 (0.79)	M12 × 24 (0.94)	201 (443)
55A□BT76	390 (15.4)	345 (13.6)	430 (16.9)	5 (0.2)	22 (0.87)	110 (4.33)	8 (0.31)	18 (0.71)	110 (4.33)	100 (3.94)	80 (3.15)	14 (0.55)	9 (0.35)	22 (0.87)	M12 × 24 (0.94)	232 (511)

• Dimensional Tolerances

Model SGMGH-	Flange Face Dimensions mm (in)		Shaft-end Dimensions mm (in)	
	LB		S	
03A□BTA6	110 ^{+0.036} _{-0.090}	(4.33 ^{+0.0014} _{-0.0035})	28 ⁺⁰ _{-0.013}	(1.11 ⁺⁰ _{-0.0005})
03A□BTB6	110 ^{+0.036} _{-0.090}	(4.33 ^{+0.0014} _{-0.0035})	28 ⁺⁰ _{-0.013}	(1.11 ⁺⁰ _{-0.0005})
03A□BTC6	110 ^{+0.036} _{-0.090}	(4.33 ^{+0.0014} _{-0.0035})	28 ⁺⁰ _{-0.013}	(1.11 ⁺⁰ _{-0.0005})
03A□BT76	110 ^{+0.036} _{-0.090}	(4.33 ^{+0.0014} _{-0.0035})	28 ⁺⁰ _{-0.013}	(1.11 ⁺⁰ _{-0.0005})
06A□BTA6	110 ^{+0.036} _{-0.090}	(4.33 ^{+0.0014} _{-0.0035})	28 ⁺⁰ _{-0.013}	(1.11 ⁺⁰ _{-0.0005})
06A□BTB6	110 ^{+0.036} _{-0.090}	(4.33 ^{+0.0014} _{-0.0035})	28 ⁺⁰ _{-0.013}	(1.11 ⁺⁰ _{-0.0005})
06A□BTC6	140 ^{+0.043} _{-0.090}	(5.51 ^{+0.0017} _{-0.0035})	38 ⁺⁰ _{-0.016}	(1.51 ⁺⁰ _{-0.0006})
06A□BT76	140 ^{+0.043} _{-0.090}	(5.51 ^{+0.0017} _{-0.0035})	38 ⁺⁰ _{-0.016}	(1.51 ⁺⁰ _{-0.0006})
09A□BTA6	110 ^{+0.036} _{-0.090}	(4.33 ^{+0.0014} _{-0.0035})	28 ⁺⁰ _{-0.013}	(1.11 ⁺⁰ _{-0.0005})
09A□BTB6	110 ^{+0.036} _{-0.090}	(4.33 ^{+0.0014} _{-0.0035})	28 ⁺⁰ _{-0.013}	(1.11 ⁺⁰ _{-0.0005})
09A□BTC6	140 ^{+0.043} _{-0.090}	(5.51 ^{+0.0017} _{-0.0035})	38 ⁺⁰ _{-0.016}	(1.51 ⁺⁰ _{-0.0006})
09A□BT76	140 ^{+0.043} _{-0.090}	(5.51 ^{+0.0017} _{-0.0035})	38 ⁺⁰ _{-0.016}	(1.51 ⁺⁰ _{-0.0006})
12A□BTA6	140 ^{+0.043} _{-0.090}	(5.51 ^{+0.0017} _{-0.0035})	38 ⁺⁰ _{-0.016}	(1.51 ⁺⁰ _{-0.0006})
12A□BTB6	140 ^{+0.043} _{-0.090}	(5.51 ^{+0.0017} _{-0.0035})	38 ⁺⁰ _{-0.016}	(1.51 ⁺⁰ _{-0.0006})
12A□BTC6	200 ^{+0.050} _{-0.122}	(7.87 ^{+0.0020} _{-0.0048})	50 ⁺⁰ _{-0.016}	(1.98 ⁺⁰ _{-0.0006})
12A□BT76	200 ^{+0.050} _{-0.122}	(7.87 ^{+0.0020} _{-0.0048})	50 ⁺⁰ _{-0.016}	(1.98 ⁺⁰ _{-0.0006})
20A□BTA6	140 ^{+0.043} _{-0.090}	(5.51 ^{+0.0017} _{-0.0035})	38 ⁺⁰ _{-0.016}	(1.51 ⁺⁰ _{-0.0006})
20A□BTB6	140 ^{+0.043} _{-0.090}	(5.51 ^{+0.0017} _{-0.0035})	38 ⁺⁰ _{-0.016}	(1.51 ⁺⁰ _{-0.0006})
20A□BTC6	200 ^{+0.050} _{-0.122}	(7.87 ^{+0.0020} _{-0.0048})	50 ⁺⁰ _{-0.016}	(1.98 ⁺⁰ _{-0.0006})
20A□BT76	270 ^{+0.056} _{-0.137}	(10.63 ^{+0.0022} _{-0.0054})	60 ⁺⁰ _{-0.019}	(2.38 ⁺⁰ _{-0.0008})
30A□BTA6	200 ^{+0.050} _{-0.122}	(7.87 ^{+0.0020} _{-0.0048})	50 ⁺⁰ _{-0.016}	(1.98 ⁺⁰ _{-0.0006})
30A□BTB6	200 ^{+0.050} _{-0.122}	(7.87 ^{+0.0020} _{-0.0048})	50 ⁺⁰ _{-0.016}	(1.98 ⁺⁰ _{-0.0006})

Model SGMGH-	Flange Face Dimensions mm (in)		Shaft-end Dimensions mm (in)	
	LB		S	
30A□BTC6	270 ^{+0.056} _{-0.137}	(10.63 ^{+0.0022} _{-0.0054})	60 ⁰ _{-0.019}	(2.38 ⁰ _{-0.0008})
30A□BT76	316 ^{+0.062} _{-0.151}	(12.44 ^{+0.0024} _{-0.0059})	70 ⁰ _{-0.019}	(2.78 ⁰ _{-0.0008})
40A□BTA6	200 ^{+0.050} _{-0.122}	(7.87 ^{+0.0020} _{-0.0048})	50 ⁰ _{-0.016}	(1.98 ⁰ _{-0.0006})
40A□BTB6	200 ^{+0.050} _{-0.122}	(7.87 ^{+0.0020} _{-0.0048})	50 ⁰ _{-0.016}	(1.98 ⁰ _{-0.0006})
40A□BTC6	316 ^{+0.062} _{-0.151}	(12.44 ^{+0.0024} _{-0.0059})	70 ⁰ _{-0.019}	(2.78 ⁰ _{-0.0008})
40A□BT76	316 ^{+0.062} _{-0.151}	(12.44 ^{+0.0024} _{-0.0059})	70 ⁰ _{-0.019}	(2.78 ⁰ _{-0.0008})
55A□BTB6	270 ^{+0.056} _{-0.137}	(10.63 ^{+0.0022} _{-0.0054})	60 ⁰ _{-0.019}	(2.38 ⁰ _{-0.0008})
55A□BTC6	316 ^{+0.062} _{-0.151}	(12.44 ^{+0.0024} _{-0.0059})	70 ⁰ _{-0.019}	(2.78 ⁰ _{-0.0008})
55A□BT76	345 ^{+0.062} _{-0.151}	(13.6 ^{+0.0024} _{-0.0059})	80 ⁰ _{-0.022}	(3.1 ⁰ _{-0.0008})

■ Servomotors Without Brakes and With Low-Backlash Gears for 1000 r/min



Flange Type

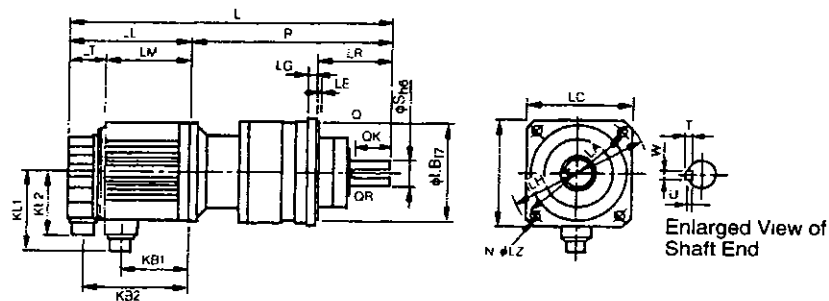

Figure 4.13 Smaller Grease Lubricating Type

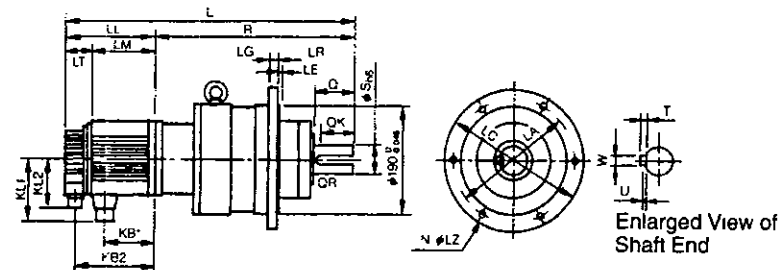
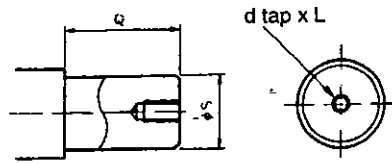

Figure 4.14 Larger Grease Lubricating Type

● Applied Specifications of Shaft End Tap



Gear Frame No.	Shaft Diameter (S)	Shaft Length (Q)	d x L (mm)
BL2	35	55	M8 x 16
BL3	50	75	M10 x 20
BL4	60	90	M12 x 24

● Enlarged View of IMT Gear

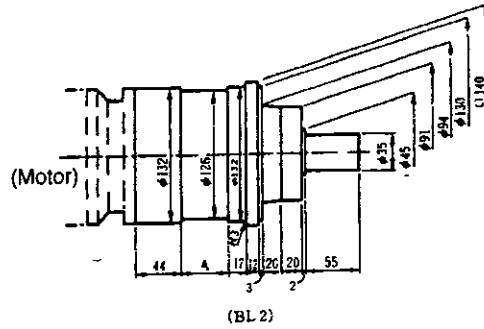

Gear Ratio	A
1/5	6
1/9	18
1/20, 1/29	39
1/45	47

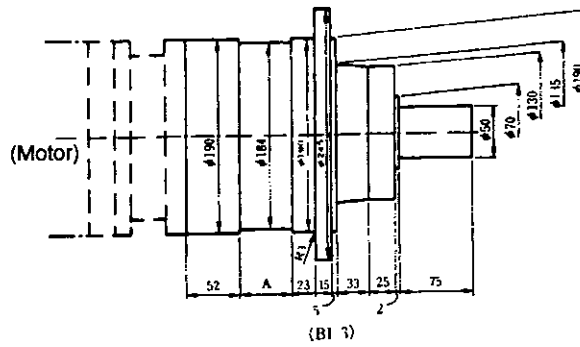

Gear Ratio	A
1/5	11
1/9	38
1/20, 1/29	46
1/45	52

Servodrive Dimensional Drawings

4 1 4 SGMGH Servomotors (1000 r/min)

Model SGMGH-	Gear Type	Gear Ratio	Fig No	L	LL	LM	LR	LT	KB1	KB2	KL1	KL2	R	Allowabl Radial Load on Center c Shaft N (lbf)
12A□BL54	BL4	1/20	4 14	581 (22 9)	166 (6 54)	119 (4 69)	160 (5 51)	47 (1 85)	89 (3 5)	145 (5 71)	140 (5 51)	88 (3 46)	415 (16 3)	6080 (1365)
12A□BL74		1/29	4 14	581 (22 9)	166 (6 54)	119 (4 69)	160 (5 51)	47 (1 85)	89 (3 5)	145 (5 71)	140 (5 51)	88 (3 46)	415 (16 3)	6860 (1540)
12A□BL84		1/45	4 14	591 (23 3)	166 (6 54)	119 (4 69)	160 (5 51)	47 (1 85)	89 (3 5)	145 (5 71)	140 (5 51)	88 (3 46)	425 (16 7)	8040 (1805)
20A□BL14	BL3	1/5	4 14	535 (21 1)	192 (7 56)	145 (5 71)	140 (5 51)	47 (1 85)	115 (4 53)	171 (6 73)	140 (5 51)	88 (3 46)	343 (13 5)	1670 (375)
20A□BL24		1/9	4 14	562 (22 1)	192 (7 56)	145 (5 71)	140 (5 51)	47 (1 85)	115 (4 53)	171 (6 73)	140 (5 51)	88 (3 46)	370 (14 6)	1960 (440)
20A□BL54	BL4	1/20	4 14	607 (23 9)	192 (7 56)	145 (5 71)	160 (5 51)	47 (1 85)	115 (4 53)	171 (6 73)	140 (5 51)	88 (3 46)	415 (16 3)	6080 (1365)
30A□BL14	BL4	1/5	4 14	609 (24)	226 (8 9)	179 (7 05)	160 (5 51)	47 (1 85)	149 (5 87)	205 (8 07)	140 (5 51)	88 (3 46)	383 (15 1)	3820 (858)
30A□BL24		1/9	4 14	641 (25 2)	226 (8 9)	179 (7 05)	160 (5 51)	47 (1 85)	149 (5 87)	205 (8 07)	140 (5 51)	88 (3 46)	415 (16 3)	4700 (1055)

**Table 4.48 Servomotors Without Brakes and With Standard Backlash Gears f
1000 r/min (SGMGH-03A□BL□4 to 30A□BL□4, LA to W)**

Model SGMGH-	Flange Face Dimensions mm (in)										Shaft-end Dimensions mm (in)						Approx Mass kg (lb)
	LA	LB	LC	LE	LG	LR	N	LZ	Q	QK	QR	S	T	U	W		
03A□BL14	160 (6 3)	130 (5 12)	140 (5 51)	3 (0 12)	12 (0 47)	185 (7 28)	4 (0 16)	12 (0 47)	55 (2 17)	47 (1 85)	1 (0 039)	35 (1 38)	8 (0 31)	5 (0 2)	10 (0 39)	14 (30 9)	
03A□BL24	160 (6 3)	130 (5 12)	140 (5 51)	3 (0 12)	12 (0 47)	185 (7 28)	4 (0 16)	12 (0 47)	55 (2 17)	47 (1 85)	1 (0 039)	35 (1 38)	8 (0 31)	5 (0 2)	10 (0 39)	14 (30 9)	
03A□BL54	160 (6 3)	130 (5 12)	140 (5 51)	3 (0 12)	12 (0 47)	185 (7 28)	4 (0 16)	12 (0 47)	55 (2 17)	47 (1 85)	1 (0 039)	35 (1 38)	8 (0 31)	5 (0 2)	10 (0 39)	16 (35 3)	
03A□BL74	220 (8 66)	190 (7 48)	245 (9 65)	5 (0 2)	15 (0 59)	-	6 (0 24)	12 (0 47)	75 (2 95)	65 (2 56)	1 (0 039)	50 (1 97)	9 (0 35)	5 5 (0 22)	14 (0 55)	31 (68 3)	
03A□BL84	220 (8 66)	190 (7 48)	245 (9 65)	5 (0 2)	15 (0 59)	-	6 (0 24)	12 (0 47)	75 (2 95)	65 (2 56)	1 (0 039)	50 (1 97)	9 (0 35)	5 5 (0 22)	14 (0 55)	31 (68 3)	
06A□BL14	160 (6 3)	130 (5 12)	140 (5 51)	3 (0 12)	12 (0 47)	185 (7 28)	4 (0 16)	12 (0 47)	55 (2 17)	47 (1 85)	1 (0 039)	35 (1 38)	8 (0 31)	5 (0 2)	10 (0 39)	16 (35 3)	
06A□BL24	160 (6 3)	130 (5 12)	140 (5 51)	3 (0 12)	12 (0 47)	185 (7 28)	4 (0 16)	12 (0 47)	55 (2 17)	47 (1 85)	1 (0 039)	35 (1 38)	8 (0 31)	5 (0 2)	10 (0 39)	16 (35 3)	
06A□BL54	220 (8 66)	190 (7 48)	245 (9 65)	5 (0 2)	15 (0 59)	-	6 (0 24)	12 (0 47)	75 (2 95)	65 (2 56)	1 (0 039)	50 (1 97)	9 (0 35)	5 5 (0 22)	14 (0 55)	33 (72 8)	
06A□BL74	220 (8 66)	190 (7 48)	245 (9 65)	5 (0 2)	15 (0 59)	-	6 (0 24)	12 (0 47)	75 (2 95)	65 (2 56)	1 (0 039)	50 (1 97)	9 (0 35)	5 5 (0 22)	14 (0 55)	33 (72 8)	
06A□BL84	280 (11)	240 (9 45)	310 (12 2)	5 (0 2)	18 (0 71)	-	6 (0 24)	14 (0 55)	90 (3 54)	78 (3 07)	1 (0 039)	60 (2 36)	11 (0 43)	7 (0 28)	18 (0 71)	53 (117)	
09A□BL14	160 (6 3)	130 (5 12)	140 (5 51)	3 (0 12)	12 (0 47)	185 (7 28)	4 (0 16)	12 (0 47)	55 (2 17)	47 (1 85)	1 (0 039)	35 (1 38)	8 (0 31)	5 (0 2)	10 (0 39)	18 (39 7)	
09A□BL24	220 (8 66)	190 (7 48)	245 (9 65)	5 (0 2)	15 (0 59)	-	6 (0 24)	12 (0 47)	75 (2 95)	65 (2 56)	1 (0 039)	50 (1 97)	9 (0 35)	5 5 (0 22)	14 (0 55)	35 (77 2)	
09A□BL54	220 (8 66)	190 (7 48)	245 (9 65)	5 (0 2)	15 (0 59)	-	6 (0 24)	12 (0 47)	75 (2 95)	65 (2 56)	1 (0 039)	50 (1 97)	9 (0 35)	5 5 (0 22)	14 (0 55)	35 (77 2)	
09A□BL74	280 (11)	240 (9 45)	310 (12 2)	5 (0 2)	18 (0 71)	-	6 (0 24)	14 (0 55)	90 (3 54)	78 (3 07)	1 (0 039)	60 (2 36)	11 (0 43)	7 (0 28)	18 (0 71)	55 (121)	
09A□BL84	280 (11)	240 (9 45)	310 (12 2)	5 (0 2)	18 (0 71)	-	6 (0 24)	14 (0 55)	90 (3 54)	78 (3 07)	1 (0 039)	60 (2 36)	11 (0 43)	7 (0 28)	18 (0 71)	55 (121)	
12A□BL14	220 (8 66)	190 (7 48)	245 (9 65)	5 (0 2)	15 (0 59)	-	6 (0 24)	12 (0 47)	75 (2 95)	65 (2 56)	1 (0 039)	50 (1 97)	9 (0 35)	5 5 (0 22)	14 (0 55)	32 (70 5)	
12A□BL24	220 (8 66)	190 (7 48)	245 (9 65)	5 (0 2)	15 (0 59)	-	6 (0 24)	12 (0 47)	75 (2 95)	65 (2 56)	1 (0 039)	50 (1 97)	9 (0 35)	5 5 (0 22)	14 (0 55)	39 (86)	

Model SGMGH-	Flange Face Dimensions mm (in)								Shaft-end Dimensions mm (in)							Approx Mass kg (lb)
	LA	LB	LC	LE	LG	LR	N	LZ	Q	QK	QR	S	T	U	W	
12A□BL54	280 (11)	240 (9.45)	310 (12.2)	5 (0.2)	18 (0.71)	-	6 (0.24)	14 (0.55)	90 (3.54)	78 (3.07)	1 (0.039)	60 (2.36)	11 (0.43)	7 (0.28)	18 (0.71)	59 (130)
12A□BL74	280 (11)	240 (9.45)	310 (12.2)	5 (0.2)	18 (0.71)	-	6 (0.24)	14 (0.55)	90 (3.54)	78 (3.07)	1 (0.039)	60 (2.36)	11 (0.43)	7 (0.28)	18 (0.71)	59 (130)
12A□BL84	280 (11)	240 (9.45)	310 (12.2)	5 (0.2)	18 (0.71)	-	6 (0.24)	14 (0.55)	90 (3.54)	78 (3.07)	1 (0.039)	60 (2.36)	11 (0.43)	7 (0.28)	18 (0.71)	59 (130)
20A□BL14	220 (8.66)	190 (7.48)	245 (9.65)	5 (0.2)	15 (0.59)	-	6 (0.24)	12 (0.47)	75 (2.95)	65 (2.56)	1 (0.039)	50 (1.97)	9 (0.35)	5.5 (0.22)	14 (0.55)	36 (79.4)
20A□BL24	220 (8.66)	190 (7.48)	245 (9.65)	5 (0.2)	15 (0.59)	-	6 (0.24)	12 (0.47)	75 (2.95)	65 (2.56)	1 (0.039)	50 (1.97)	9 (0.35)	5.5 (0.22)	14 (0.55)	43 (94.8)
20A□BL54	280 (11)	240 (9.45)	310 (12.2)	5 (0.2)	18 (0.71)	-	6 (0.24)	14 (0.55)	90 (3.54)	78 (3.07)	1 (0.039)	60 (2.36)	11 (0.43)	7 (0.28)	18 (0.71)	63 (139)
30A□BL14	280 (11)	240 (9.45)	310 (12.2)	5 (0.2)	18 (0.71)	-	6 (0.24)	14 (0.55)	90 (3.54)	78 (3.07)	1 (0.039)	60 (2.36)	11 (0.43)	7 (0.28)	18 (0.71)	58 (128)
30A□BL24	280 (11)	240 (9.45)	310 (12.2)	5 (0.2)	18 (0.71)	-	6 (0.24)	14 (0.55)	90 (3.54)	78 (3.07)	1 (0.039)	60 (2.36)	11 (0.43)	7 (0.28)	18 (0.71)	68 (150)



4.1.5 SGMSH Servomotors

- SGMSH-□□ A2A Servomotors with 17-bit Absolute Encoders and SGMSH-□□ ACA Servomotors with 17-bit Incremental Encoders

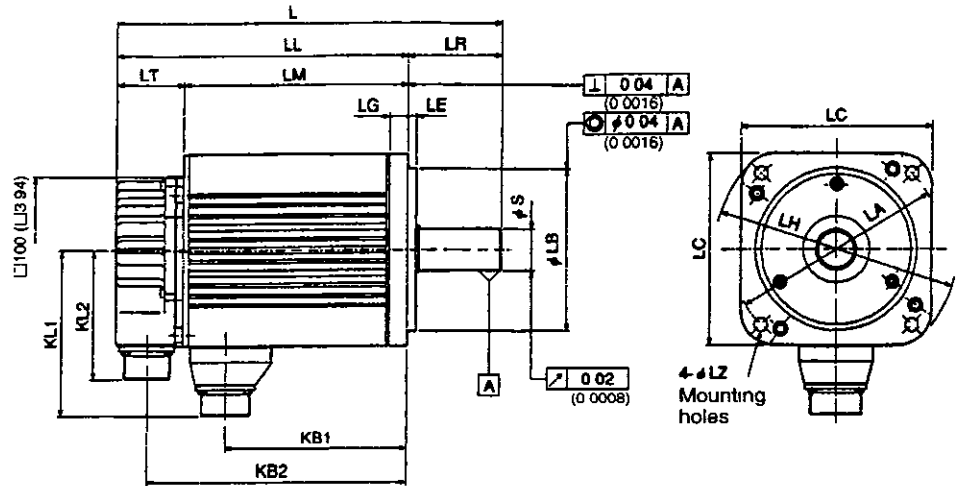

Enlarged View of Shaft End

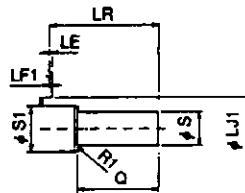

Table 4 49 SGMSH-□□ A2A Servomotors with 17-bit Absolute Encoders and SGMSH-□□ ACA Servomotors with 17-bit Incremental Encoders (L to KL2)

Units mm (in)

Model SGMSH-	L	LL	LM	LR	LT	KB1	KB2	KL1	KL2
10A□A	194 (7.64)	149 (5.87)	103 (4.06)	45 (1.77)	46 (1.81)	76 (2.99)	128 (5.04)	96 (3.78)	87 (3.43)
15A□A	220 (8.66)	175 (6.89)	129 (5.08)	45 (1.77)	46 (1.81)	102 (4.02)	154 (6.06)	96 (3.78)	87 (3.43)
20A□A	243 (9.57)	198 (7.80)	152 (5.98)	45 (1.77)	46 (1.81)	125 (4.92)	177 (6.97)	96 (3.78)	87 (3.43)
30A□A	262 (10.31)	199 (7.83)	153 (6.02)	63 (2.48)	46 (1.81)	122 (4.80)	178 (7.01)	114 (4.49)	87 (3.43)
40A□A	299 (11.8)	236 (9.29)	190 (7.48)	63 (2.48)	46 (1.81)	159 (6.26)	215 (8.46)	114 (4.49)	87 (3.43)
50A□A	339 (13.3)	276 (10.9)	230 (9.06)	63 (2.48)	46 (1.81)	199 (7.83)	255 (10.04)	114 (4.49)	87 (3.43)

Table 4.50 SGMSH-□□ A2A Servomotors with 17-bit Absolute Encoders and
 SGMSH-□□ ACA Servomotors with 17-bit Incremental Encoders (LA to Q)

Model SGMSH-	Flange Face Dimensions mm (in)									Shaft-end Dimensions mm (in)			Approx Mass kg (lb)
	LA	LB	LC	LE	LF	LG	LH	LJ	LZ	S	S1	Q	
10A□A	115 (4.53)	$\begin{matrix} 95 \\ 0 \\ -0.035 \\ \hline 3.74 \\ 0 \\ -0.0014 \end{matrix}$	100 (3.94)	3 (0.12)	3 (0.12)	10 (0.39)	130 (5.12)	45 (1.77)	7 (0.28)	$\begin{matrix} 24 \\ 0 \\ -0.013 \\ \hline 0.94 \\ 0 \\ -0.0005 \end{matrix}$	30 (1.18)	40 (1.57)	4.6 (10.14)
15A□A	115 (4.53)	$\begin{matrix} 95 \\ 0 \\ -0.035 \\ \hline 3.74 \\ 0 \\ -0.0014 \end{matrix}$	100 (3.94)	3 (0.12)	3 (0.12)	10 (0.39)	130 (5.12)	45 (1.77)	7 (0.28)	$\begin{matrix} 24 \\ 0 \\ -0.013 \\ \hline 0.94 \\ 0 \\ -0.0005 \end{matrix}$	30 (1.18)	40 (1.57)	5.8 (12.79)
20A□A	115 (4.53)	$\begin{matrix} 95 \\ 0 \\ -0.035 \\ \hline 3.74 \\ 0 \\ -0.0014 \end{matrix}$	100 (3.94)	3 (0.12)	3 (0.12)	10 (0.39)	130 (5.12)	45 (1.77)	7 (0.28)	$\begin{matrix} 24 \\ 0 \\ -0.013 \\ \hline 0.94 \\ 0 \\ -0.0005 \end{matrix}$	30 (1.18)	40 (1.57)	7.0 (15.43)
30A□A	145 (5.71)	$\begin{matrix} 110 \\ 0 \\ -0.035 \\ \hline 4.33 \\ 0 \\ -0.0014 \end{matrix}$	130 (5.12)	6 (0.24)	6 (0.24)	12 (0.47)	165 (6.50)	45 (1.77)	9 (0.35)	$\begin{matrix} 28 \\ 0 \\ -0.013 \\ \hline 1.10 \\ 0 \\ -0.0005 \end{matrix}$	30 (1.18)	55 (2.17)	11 (24.3)
40A□A	145 (5.71)	$\begin{matrix} 110 \\ 0 \\ -0.035 \\ \hline 4.33 \\ 0 \\ -0.0014 \end{matrix}$	130 (5.12)	6 (0.24)	6 (0.24)	12 (0.47)	165 (6.50)	45 (1.77)	9 (0.35)	$\begin{matrix} 28 \\ 0 \\ -0.013 \\ \hline 1.10 \\ 0 \\ -0.0005 \end{matrix}$	30 (1.18)	55 (2.17)	14 (30.9)
50A□A	145 (5.71)	$\begin{matrix} 110 \\ 0 \\ -0.035 \\ \hline 4.33 \\ 0 \\ -0.0014 \end{matrix}$	130 (5.12)	6 (0.24)	6 (0.24)	12 (0.47)	165 (6.50)	45 (1.77)	9 (0.35)	$\begin{matrix} 28 \\ 0 \\ -0.013 \\ \hline 1.10 \\ 0 \\ -0.0005 \end{matrix}$	30 (1.18)	55 (2.17)	17 (37.5)

Note The detector is a 17-bit encoder (absolute/incremental)

Cable Specifications for Detector Connectors (17-bit Encoder)

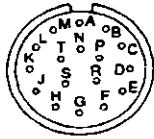

Receptacle MS3102A20-29P
 Applicable plug (purchased by the customer)
 Plug MS3108B20-29S
 Cable clamp MS3057-12A

• **Servomotors with Absolute Encoders**

A	-	K	-
B	-	L	-
C	DATA+	M	-
D	DATA-	N	-
E	-	P	-
F	-	R	-
G	0V	S	BATT-
H	+5VDC	T	BATT+
J	FG (Frame ground)		-

• **Servomotors with Incremental Encoders**

A	-	K	-
B	-	L	-
C	DATA+	M	-
D	DATA-	N	-
E	-	P	-
F	-	R	-
G	0V	S	-
H	+5VDC	T	-
J	FG (Frame ground)		-

Cable Specifications for Servomotor Connectors



A	Phase U
B	Phase V
C	Phase W
D	FG (Frame ground)

■ Servomotors with 17-bit Encoders (Absolute/Incremental) and Brakes

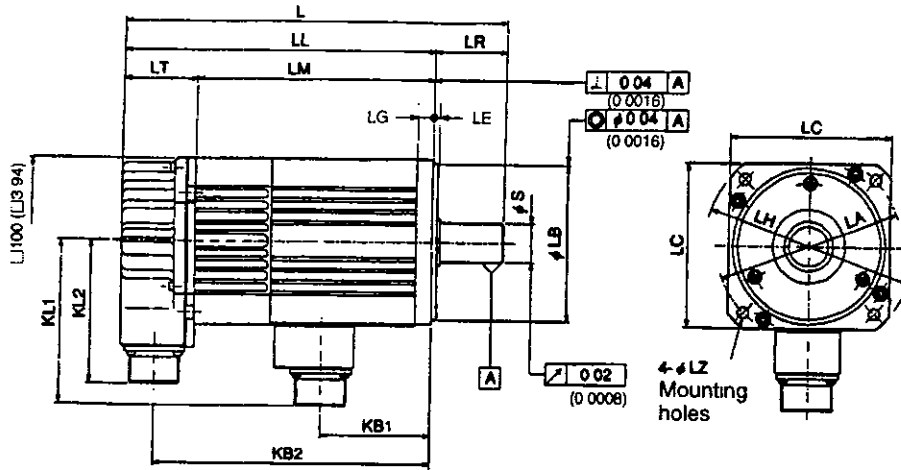

Enlarged View of Shaft End

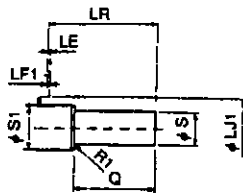

Table 4.51 Servomotors with 17-bit Encoders (Absolute/Incremental) and Brakes (L to KL2) Units: mm (in)

Model SGMSH-	L	LL	LM	LR	LT	KB1	KB2	KL1	KL2
10A□A□B	238 (9 37)	193 (7 60)	147 (5 79)	45 (1 77)	46 (1 81)	67 (2 64)	172 (6 77)	100 (3 94)	87 (3 43)
15A□A□B	264 (10 39)	219 (8 62)	173 (6 81)	45 (1 77)	46 (1 81)	93 (3 66)	198 (7 80)	100 (3 94)	87 (3 43)
20A□A□B	287 (11 30)	242 (9 53)	196 (7 72)	45 (1 77)	46 (1 81)	116 (4 57)	221 (8 70)	100 (3 94)	87 (3 43)
30A□A□B	300 (11 81)	237 (9 33)	191 (7 52)	63 (2 48)	46 (1 81)	113 (4 45)	216 (8 50)	119 (4 69)	87 (3 43)
40A□A□B	336 (13 2)	274 (10 8)	228 (8 98)	63 (2 48)	46 (1 81)	150 (5 91)	253 (9 96)	119 (4 69)	87 (3 43)
50A□A□B	337 (13 3)	314 (12 4)	268 (10 6)	63 (2 48)	46 (1 81)	190 (7 48)	293 (11 5)	119 (4 69)	87 (3 43)

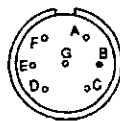

Table 4 52 Servomotors with 17-bit Encoders (Absolute/Incremental) and Brake (LA to Q)

Model SGMSH-	Flange Face Dimensions mm (in)									Shaft-end Dimensions mm (in)			Approx. Mass kg (lb)
	LA	LB	LC	LE	LF	LG	LH	LJ	LZ	S	S1	Q	
10A□A□B	115 (4 53)	$95^{0}_{-0.035}$ $(3 74^{0}_{-0.0014})$	100 (3 94)	3 (0 12)	3 (0 12)	10 (0 39)	130 (5 12)	45 (1 77)	7 (0 28)	$24^{0}_{-0.013}$ $(0 94^{0}_{-0.0005})$	30 (1 18)	40 (1 57)	6 0 (13 23)
15A□A□B	115 (4 53)	$95^{c}_{-0.035}$ $(3 74^{c}_{-0.0014})$	100 (3 94)	3 (0 12)	3 (0 12)	10 (0 39)	130 (5 12)	45 (1 77)	7 (0 28)	$24^{0}_{-0.013}$ $(0 94^{0}_{-0.0005})$	30 (1 18)	40 (1 57)	7 5 (16 54)
20A□A□B	115 (4 53)	$95^{0}_{-0.035}$ $(3 74^{0}_{-0.0014})$	100 (3 94)	3 (0 12)	3 (0 12)	10 (0 39)	130 (5 12)	45 (1 77)	7 (0 28)	$24^{0}_{-0.013}$ $(0 94^{0}_{-0.0005})$	30 (1 18)	40 (1 57)	8 5 (18 74)
30A□A□B	145 (5 71)	$110^{0}_{-0.035}$ $(4 33^{0}_{-0.0014})$	130 (5 12)	6 (0 24)	6 (0 24)	12 (0 47)	165 (6 50)	45 (1 77)	9 (0 28)	$28^{0}_{-0.013}$ $(1 10^{0}_{-0.0005})$	30 (1 18)	55 (2 17)	14 (30 9)
40A□A□B	145 (5 71)	$110^{0}_{-0.035}$ $(4 33^{0}_{-0.0014})$	130 (5 12)	6 (0 24)	6 (0 24)	12 (0 47)	165 (6 50)	45 (1 77)	9 (0 28)	$28^{0}_{-0.013}$ $(1 10^{0}_{-0.0005})$	30 (1 18)	55 (2 17)	17 (37 5)
50A□A□B	145 (5 71)	$110^{0}_{-0.035}$ $(4 33^{0}_{-0.0014})$	130 (5 12)	6 (0 24)	6 (0 24)	12 (0 47)	165 (6 50)	45 (1 77)	9 (0 28)	$28^{0}_{-0.013}$ $(1 10^{0}_{-0.0005})$	30 (1 18)	55 (2 17)	20 (44 1)

Note The detector is a 17-bit encoder (absolute/incremental)

Cable Specifications for Servomotor Connectors



A	Phase U	E	Brake terminal
B	Phase V	F	Brake terminal
C	Phase W	G	-
D	FG (Frame ground)		-

■ **Servomotors Without Brakes and With Low-Backlash Gears for 3000 r/min**

Flange Type

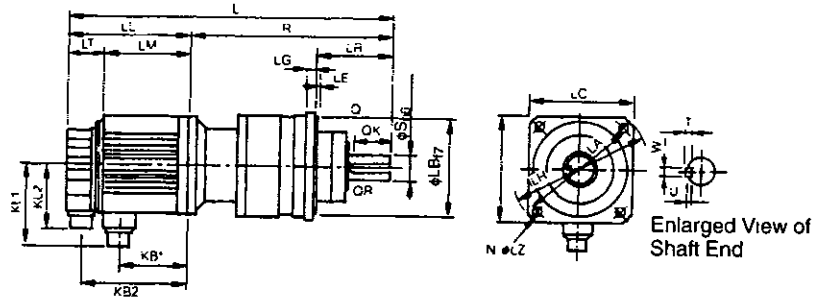

Figure 4.15 Smaller Grease Lubricating Type

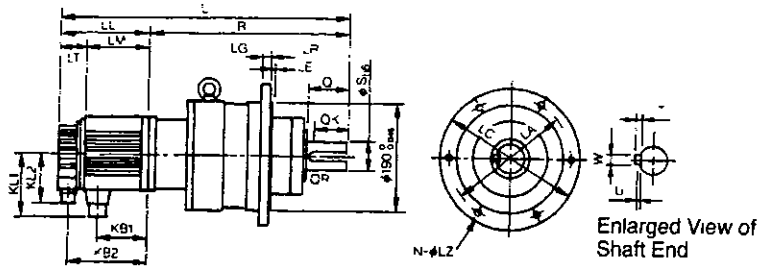
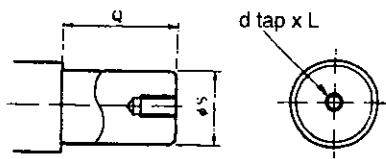

Figure 4.16 Larger Grease Lubricating Type

● **Applied Specifications of Shaft End Tap**



Gear Frame No	Shaft Diameter (S)	Shaft Length (Q)	d x L (mm)
BL2	35	55	M8 × 16
BL3	50	75	M10 × 20
BL4	60	90	M12 × 24



● Enlarged View of IMT Gear

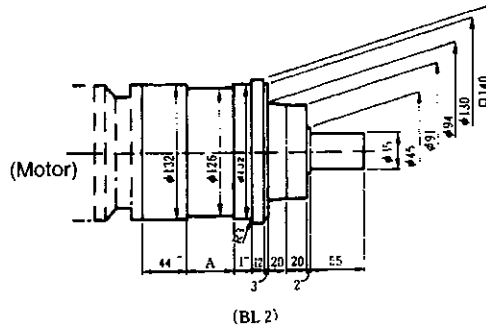

(BL 2)

Gear Ratio	A
1/5	6
1/9	18
1/20, 1/29	39
1/45	47

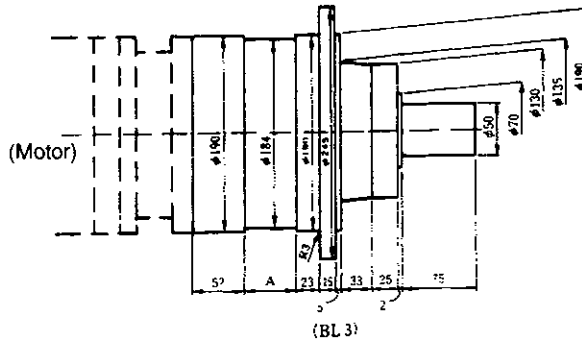

(BL 3)

Gear Ratio	A
1/5	11
1/9	38
1/20, 1/29	46
1/45	52

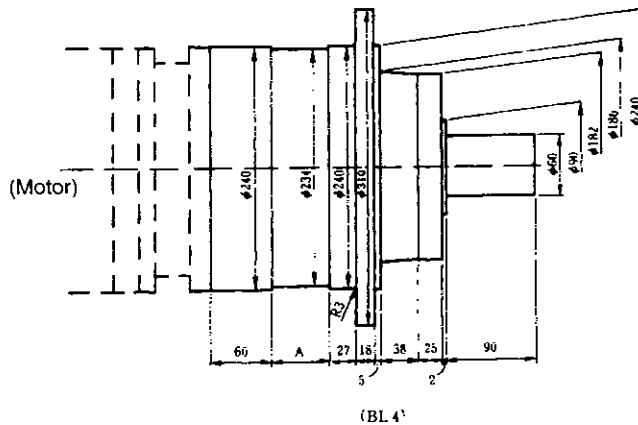

(BL 4)

Gear Ratio	A
1/5	16
1/9	48
1/20, 1/29	55
1/45	58

Table 4 53 Servomotors Without Brakes and With Low-Backlash Gears for 3000 r/min (L to R)

Model SGMGH-	Gear Type	Gear Ratio	Fig No	L	LL	LM	LR	LT	KB1	KB2	KL1	KL2	R	Allowable Radial Load on Center of Shaft N (lbf)
10A□AL14	BL2	1/5	4 15	40 ³ (15 9)	149 (5 87)	103 (4 06)	100 (3 94)	46 (1 81)	76 (2 99)	128 (5 04)	96 (3 78)	87 (3 43)	254 (1)	833 (187)
10A□AL24		1/9	4 15	415 (16 3)	149 (5 87)	103 (4 06)	100 (3 94)	46 (1 81)	76 (2 99)	128 (5 04)	96 (3 78)	87 (3 43)	266 (10 5)	980 (220)
10A□AL54	BL3	1/20	4 16	496 (19 5)	149 (5 87)	103 (4 06)	140 (5 51)	46 (1 81)	76 (2 99)	128 (5 04)	96 (3 78)	87 (3 43)	347 (13 7)	2650 (595)
10A□AL74		1/29	4 16	496 (19 5)	149 (5 87)	103 (4 06)	140 (5 51)	46 (1 81)	76 (2 99)	128 (5 04)	96 (3 78)	87 (3 43)	347 (13 7)	2940 (660)
10A□AL84		1/45	4 16	506 (19 9)	149 (5 87)	103 (4 06)	140 (5 51)	46 (1 81)	76 (2 99)	128 (5 04)	96 (3 78)	87 (3 43)	357 (14 1)	3430 (770)

Model SGMGH-	Gear Type	Gear Ratio	Fig No	L	LL	LM	LR	LT	KB1	KB2	KL1	KL2	R	Allowable Radial Load on Center of Shaft N (lbf)
15A□AL14	BL2	1/5	4 15	429 (16 9)	175 (6 89)	129 (5 08)	100 (3 94)	46 (1 81)	102 (4 02)	154 (6 06)	96 (3 78)	87 (3 43)	254 (1)	833 (187)
15A□AL24	BL3	1/9	4 16	518 (20 4)	175 (6 89)	129 (5 08)	140 (5 51)	46 (1 81)	102 (4 02)	154 (6 06)	96 (3 78)	87 (3 43)	343 (13 5)	1960 (440)
15A□AL54		1/20	4 16	522 (20 6)	175 (6 89)	129 (5 08)	140 (5 51)	46 (1 81)	102 (4 02)	154 (6 06)	96 (3 78)	87 (3 43)	347 (13 7)	2650 (595)
15A□AL74		1/29	4 16	522 (20 6)	175 (6 89)	129 (5 08)	140 (5 51)	46 (1 81)	102 (4 02)	154 (6 06)	96 (3 78)	87 (3 43)	347 (13 7)	2940 (660)
15A□AL84	BL4	1/45	4 16	573 (22 6)	175 (6 89)	129 (5 08)	160 (6 3)	46 (1 81)	102 (4 02)	154 (6 06)	96 (3 78)	87 (3 43)	398 (15 7)	8040 (1805)
20A□AL14	BL2	1/5	4 15	452 (17 8)	198 (7 8)	152 (5 98)	100 (3 94)	46 (1 81)	125 (4 92)	177 (6 97)	96 (3 78)	87 (3 43)	254 (1)	833 (187)
20A□AL24	BL3	1/9	4 16	541 (21 3)	198 (7 8)	152 (5 98)	140 (5 51)	46 (1 81)	125 (4 92)	177 (6 97)	96 (3 78)	87 (3 43)	343 (13 5)	1960 (440)
20A□AL54		1/20	4 16	545 (21 5)	198 (7 8)	152 (5 98)	140 (5 51)	46 (1 81)	125 (4 92)	177 (6 97)	96 (3 78)	87 (3 43)	347 (13 7)	2650 (595)
20A□AL74	BL4	1/29	4 16	586 (23 1)	198 (7 8)	152 (5 98)	160 (6 3)	46 (1 81)	125 (4 92)	177 (6 97)	96 (3 78)	87 (3 43)	388 (15 3)	6860 (1540)
20A□AL84		1/45	4 16	596 (23 5)	198 (7 8)	152 (5 98)	160 (6 3)	46 (1 81)	125 (4 92)	177 (6 97)	96 (3 78)	87 (3 43)	398 (15 7)	8040 (1805)
30A□AL14	BL3	1/5	4 16	540 (21 3)	199 (7 83)	153 (6 02)	140 (5 51)	46 (1 81)	122 (4 8)	178 (7 01)	114 (4 49)	87 (3 43)	341 (13 4)	1670 (375)
30A□AL24		1/9	4 16	567 (22 3)	199 (7 83)	153 (6 02)	140 (5 51)	46 (1 81)	122 (4 8)	178 (7 01)	114 (4 49)	87 (3 43)	368 (14 5)	1960 (440)
30A□AL54	BL4	1/20	4 16	612 (24 1)	199 (7 83)	153 (6 02)	160 (6 3)	46 (1 81)	122 (4 8)	178 (7 01)	114 (4 49)	87 (3 43)	413 (16 3)	6080 (1365)
30A□AL74		1/29	4 16	612 (24 1)	199 (7 83)	153 (6 02)	160 (6 3)	46 (1 81)	122 (4 8)	178 (7 01)	114 (4 49)	87 (3 43)	413 (16 3)	6860 (1540)
30A□AL84		1/45	4 16	622 (24 5)	199 (7 83)	153 (6 02)	160 (6 3)	46 (1 81)	122 (4 8)	178 (7 01)	114 (4 49)	87 (3 43)	423 (16 7)	8040 (1805)
40A□AL14	BL3	1/5	4 16	577 (22 7)	236 (9 29)	190 (7 48)	140 (5 51)	46 (1 81)	159 (6 26)	215 (8 46)	114 (4 49)	87 (3 43)	341 (13 4)	1670 (375)
40A□AL24	BL4	1/9	4 16	649 (25 6)	236 (9 29)	190 (7 48)	160 (6 3)	46 (1 81)	159 (6 26)	215 (8 46)	114 (4 49)	87 (3 43)	413 (16 3)	4700 (1055)
40A□AL54		1/20	4 16	649 (25 6)	236 (9 29)	190 (7 48)	160 (6 3)	46 (1 81)	159 (6 26)	215 (8 46)	114 (4 49)	87 (3 43)	413 (16 3)	6080 (1365)
40A□AL74		1/29	4 16	649 (25 6)	236 (9 29)	190 (7 48)	160 (6 3)	46 (1 81)	159 (6 26)	215 (8 46)	114 (4 49)	87 (3 43)	413 (16 3)	6860 (1540)
50A□AL14	BL4	1/5	4 16	657 (25 9)	276 (10 9)	230 (9 06)	160 (6 3)	46 (1 81)	199 (7 83)	255 (1)	114 (4 49)	87 (3 43)	381 (15)	3820 (858)
50A□AL24		1/9	4 16	689 (27 1)	276 (10 9)	230 (9 06)	160 (6 3)	46 (1 81)	199 (7 83)	255 (1)	114 (4 49)	87 (3 43)	413 (16 3)	4700 (1055)
50A□AL54		1/20	4 16	689 (27 1)	276 (10 9)	230 (9 06)	160 (6 3)	46 (1 81)	199 (7 83)	255 (1)	114 (4 49)	87 (3 43)	413 (16 3)	6080 (1365)

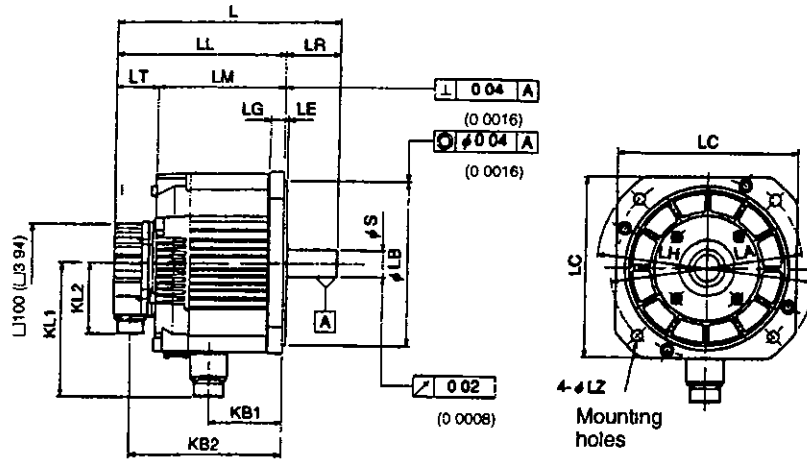

Table 4.54 Servomotors Without Brakes and With Low-Backlash Gears for 3000 r/min (LA to W)

Model SGMGH-	Flange Face Dimensions mm (in)								Shaft-end Dimensions mm (in)							Approx Mass kg (lb)
	LA	LB	LC	LE	LG	LH	N	LZ	Q	QK	QR	S	T	U	W	
10A□AL14	160 (6.3)	130 (5.12)	140 (5.51)	3 (0.12)	12 (0.47)	185 (7.28)	4 (0.16)	12 (0.47)	55 (2.17)	47 (1.85)	1 (0.039)	35 (1.38)	8 (0.31)	5 (0.2)	10 (0.39)	13 (28.7)
10A□AL24	160 (6.3)	130 (5.12)	140 (5.51)	3 (0.12)	12 (0.47)	185 (7.28)	4 (0.16)	12 (0.47)	55 (2.17)	47 (1.85)	1 (0.039)	35 (1.38)	8 (0.31)	5 (0.2)	10 (0.39)	13 (28.7)
10A□AL54	220 (8.66)	190 (7.48)	245 (9.65)	5 (0.2)	15 (0.59)	-	6 (0.24)	12 (0.47)	75 (2.95)	65 (2.56)	1 (0.039)	50 (1.97)	9 (0.35)	5.5 (0.22)	14 (0.55)	30 (66.1)
10A□AL74	220 (8.66)	190 (7.48)	245 (9.65)	5 (0.2)	15 (0.59)	-	6 (0.24)	12 (0.47)	75 (2.95)	65 (2.56)	1 (0.039)	50 (1.97)	9 (0.35)	5.5 (0.22)	14 (0.55)	30 (66.1)
10A□AL84	220 (8.66)	190 (7.48)	245 (9.65)	5 (0.2)	15 (0.59)	-	6 (0.24)	12 (0.47)	75 (2.95)	65 (2.56)	1 (0.039)	50 (1.97)	9 (0.35)	5.5 (0.22)	14 (0.55)	30 (66.1)
15A□AL14	160 (6.3)	130 (5.12)	140 (5.51)	3 (0.12)	12 (0.47)	185 (7.28)	4 (0.16)	12 (0.47)	55 (2.17)	47 (1.85)	1 (0.039)	35 (1.38)	8 (0.31)	5 (0.2)	10 (0.39)	14 (30.9)
15A□AL24	220 (8.66)	190 (7.48)	245 (9.65)	5 (0.2)	15 (0.59)	-	6 (0.24)	12 (0.47)	75 (2.95)	65 (2.56)	1 (0.039)	50 (1.97)	9 (0.35)	5.5 (0.22)	14 (0.55)	31 (68.3)
15A□AL54	220 (8.66)	190 (7.48)	245 (9.65)	5 (0.2)	15 (0.59)	-	6 (0.24)	12 (0.47)	75 (2.95)	65 (2.56)	1 (0.039)	50 (1.97)	9 (0.35)	5.5 (0.22)	14 (0.55)	31 (68.3)
15A□AL74	220 (8.66)	190 (7.48)	245 (9.65)	5 (0.2)	15 (0.59)	-	6 (0.24)	12 (0.47)	75 (2.95)	65 (2.56)	1 (0.039)	50 (1.97)	9 (0.35)	5.5 (0.22)	14 (0.55)	31 (68.3)
15A□AL84	280 (11)	240 (9.45)	310 (12.2)	5 (0.2)	18 (0.71)	-	6 (0.24)	14 (0.55)	90 (3.54)	78 (3.07)	1 (0.039)	60 (2.36)	11 (0.43)	7 (0.28)	18 (0.71)	51 (112)
20A□AL14	160 (6.3)	130 (5.12)	140 (5.51)	3 (0.12)	12 (0.47)	185 (7.28)	4 (0.16)	12 (0.47)	55 (2.17)	47 (1.85)	1 (0.039)	35 (1.38)	8 (0.31)	5 (0.2)	10 (0.39)	15 (112)
20A□AL24	220 (8.66)	190 (7.48)	245 (9.65)	5 (0.2)	15 (0.59)	-	6 (0.24)	12 (0.47)	75 (2.95)	65 (2.56)	1 (0.039)	50 (1.97)	9 (0.35)	5.5 (0.22)	14 (0.55)	32 (70.5)
20A□AL54	220 (8.66)	190 (7.48)	245 (9.65)	5 (0.2)	15 (0.59)	-	6 (0.24)	12 (0.47)	75 (2.95)	65 (2.56)	1 (0.039)	50 (1.97)	9 (0.35)	5.5 (0.22)	14 (0.55)	32 (70.5)
20A□AL74	280 (11)	240 (9.45)	310 (12.2)	5 (0.2)	18 (0.71)	-	6 (0.24)	14 (0.55)	90 (3.54)	78 (3.07)	1 (0.039)	60 (2.36)	11 (0.43)	7 (0.28)	18 (0.71)	52 (115)
20A□AL84	280 (11)	240 (9.45)	310 (12.2)	5 (0.2)	18 (0.71)	-	6 (0.24)	14 (0.55)	90 (3.54)	78 (3.07)	1 (0.039)	60 (2.36)	11 (0.43)	7 (0.28)	18 (0.71)	52 (115)
30A□AL14	220 (8.66)	190 (7.48)	245 (9.65)	5 (0.2)	15 (0.59)	-	6 (0.24)	12 (0.47)	75 (2.95)	65 (2.56)	1 (0.039)	50 (1.97)	9 (0.35)	5.5 (0.22)	14 (0.55)	29 (63.9)
30A□AL24	220 (8.66)	190 (7.48)	245 (9.65)	5 (0.2)	15 (0.59)	-	6 (0.24)	12 (0.47)	75 (2.95)	65 (2.56)	1 (0.039)	50 (1.97)	9 (0.35)	5.5 (0.22)	14 (0.55)	36 (79.4)
30A□AL54	280 (11)	240 (9.45)	310 (12.2)	5 (0.2)	18 (0.71)	-	6 (0.24)	14 (0.55)	90 (3.54)	78 (3.07)	1 (0.039)	60 (2.36)	11 (0.43)	7 (0.28)	18 (0.71)	56 (123)
30A□AL74	280 (11)	240 (9.45)	310 (12.2)	5 (0.2)	18 (0.71)	-	6 (0.24)	14 (0.55)	90 (3.54)	78 (3.07)	1 (0.039)	60 (2.36)	11 (0.43)	7 (0.28)	18 (0.71)	56 (123)
30A□AL84	280 (11)	240 (9.45)	310 (12.2)	5 (0.2)	18 (0.71)	-	6 (0.24)	14 (0.55)	90 (3.54)	78 (3.07)	1 (0.039)	60 (2.36)	11 (0.43)	7 (0.28)	18 (0.71)	56 (123)
40A□AL14	220 (8.66)	190 (7.48)	245 (9.65)	5 (0.2)	15 (0.59)	-	6 (0.24)	12 (0.47)	75 (2.95)	65 (2.56)	1 (0.039)	50 (1.97)	9 (0.35)	5.5 (0.22)	14 (0.55)	32 (70.5)
40A□AL24	280 (11)	240 (9.45)	310 (12.2)	5 (0.2)	18 (0.71)	-	6 (0.24)	14 (0.55)	90 (3.54)	78 (3.07)	1 (0.039)	60 (2.36)	11 (0.43)	7 (0.28)	18 (0.71)	59 (130)
40A□AL54	280 (11)	240 (9.45)	310 (12.2)	5 (0.2)	18 (0.71)	-	6 (0.24)	14 (0.55)	90 (3.54)	78 (3.07)	1 (0.039)	60 (2.36)	11 (0.43)	7 (0.28)	18 (0.71)	59 (130)
40A□AL74	280 (11)	240 (9.45)	310 (12.2)	5 (0.2)	18 (0.71)	-	6 (0.24)	14 (0.55)	90 (3.54)	78 (3.07)	1 (0.039)	60 (2.36)	11 (0.43)	7 (0.28)	18 (0.71)	59 (130)
50A□AL14	280 (11)	240 (9.45)	310 (12.2)	5 (0.2)	18 (0.71)	-	6 (0.24)	14 (0.55)	90 (3.54)	78 (3.07)	1 (0.039)	60 (2.36)	11 (0.43)	7 (0.28)	18 (0.71)	52 (115)
50A□AL24	280 (11)	240 (9.45)	310 (12.2)	5 (0.2)	18 (0.71)	-	6 (0.24)	14 (0.55)	90 (3.54)	78 (3.07)	1 (0.039)	60 (2.36)	11 (0.43)	7 (0.28)	18 (0.71)	62 (137)
50A□AL54	280 (11)	240 (9.45)	310 (12.2)	5 (0.2)	18 (0.71)	-	6 (0.24)	14 (0.55)	90 (3.54)	78 (3.07)	1 (0.039)	60 (2.36)	11 (0.43)	7 (0.28)	18 (0.71)	62 (137)

4.1.6 SGMDH Servomotors

- SGMDH-□□ A2A Servomotors with 17-bit Absolute Encoders and SGMDH-□□ ACA Servomotors with 17-bit Incremental Encoders (With and Without Brakes)



Enlarged View of Shaft End

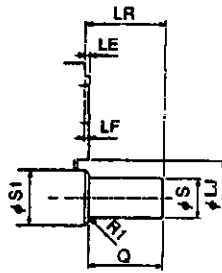

Table 4 55 SGMDH-□□ A2A Servomotors with 17-bit Absolute Encoders and SGMDH-□□ ACA Servomotors with 17-bit Incremental Encoders (With and Without Brakes, L to KL2) Units mm (in)

Model SGMSH-	L	LL	LM	LR	LT	KB1	KB2	KL1	KL2
22A□A	242 (9 53)	187 (7 36)	144 (5 67)	55 (2 17)	43 (1 69)	70 (2 76)	166 (6 54)	165 (6 5)	88 (3 46)
32A□A	254 (1)	199 (7 83)	156 (6 14)	55 (2 17)	43 (1 69)	82 (3 23)	178 (7 01)	165 (6 5)	88 (3 46)
40A□A	274 (10 8)	209 (8 23)	166 (6 54)	65 (2 56)	43 (1 69)	92 (3 62)	188 (7 4)	165 (6 5)	88 (3 46)

**Table 4 56 SGMDH-□□ A2A Servomotors with 17-bit Absolute Encoders an
SGMDH-□□ ACA Servomotors with 17-bit Incremental Encoders (With an
Without Brakes, LA to Q)**

Model SGMSH-	Flange Face Dimensions mm (in)									Shaft-end Dimensions mm (in)			Approx Mass kg (lb)	
	LA	LB	LC	LE	LF	LG	LH	LJ	LZ	S	S1	Q	Without Brakes	With Brakes
22A□A	235 (9 25)	$200 - \begin{matrix} 0 \\ 0 046 \end{matrix}$ $\left(\begin{matrix} 0 \\ 7 87 -0 0018 \end{matrix} \right)$	220 (8 66)	4 (0 16)	4 (0 16)	18 (0 71)	270 (10 6)	62 (2 44)	13 5 (0 53)	$28 - \begin{matrix} 0 \\ 0 013 \end{matrix}$ $\left(\begin{matrix} 0 \\ 1 1 -0 0006 \end{matrix} \right)$	45 (1 77)	50 (1 97)	15 5 (34 2)	20 5 (45 2)
32A□A	235 (9 25)	$-200 - \begin{matrix} 0 \\ 0 046 \end{matrix}$ $\left(\begin{matrix} 0 \\ 7 87 -0 0018 \end{matrix} \right)$	220 (8 66)	4 (0 16)	4 (0 16)	18 (0 71)	270 (10 6)	62 (2 44)	13 5 (0 53)	$28 - \begin{matrix} 0 \\ 0 013 \end{matrix}$ $\left(\begin{matrix} 0 \\ 1 1 -0 0006 \end{matrix} \right)$	45 (1 77)	50 (1 97)	18 5 (40 8)	23 5 (51 8)
40A□A	235 (9 25)	$200 - \begin{matrix} 0 \\ 0 046 \end{matrix}$ $\left(\begin{matrix} 0 \\ 7 87 -0 0018 \end{matrix} \right)$	220 (8 66)	4 (0 16)	4 (0 16)	18 (0 71)	270 (10 6)	62 (2 44)	13 5 (0 53)	$32 - \begin{matrix} 0 \\ 0 016 \end{matrix}$ $\left(\begin{matrix} 0 \\ 1 26 -0 0006 \end{matrix} \right)$	45 (1 77)	60 (2 36)	21 (46 3)	26 (57 3)

* 1 The detector is a 17-bit encoder (absolute/incremental)

* 2 For Servomotors with brakes, □B is appended to the end of each model name

Cable Specifications for Detector Connectors (17-bit Encoder)

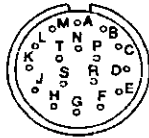

Receptacle MS3102A20-29P
 Applicable plug (purchased by the customer)
 Plug MS3108B20-29S
 Cable clamp MS3057-12A

● **Servomotors with Absolute Encoders**

A	-	K	-
B	-	L	-
C	DATA+	M	-
D	DATA-	N	-
E	-	P	-
F	-	R	-
G	0V	S	BATT-
H	+5VDC	T	BATT+
J	FG (Frame ground)		-

● **Servomotors with Incremental Encoders**

A	-	K	-
B	-	L	-
C	DATA+	M	-
D	DATA-	N	-
E	-	P	-
F	-	R	-
G	0V	S	-
H	+5VDC	T	-
J	FG (Frame ground)		-



Cable Specifications for Servomotor Connectors

● **Without Brakes**



A	Phase U
B	Phase V
C	Phase W
D	FG (Frame ground)

● **With Brakes**

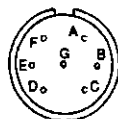

A	Phase U	E	Brake terminal
B	Phase V	F	Brake terminal
C	Phase W	G	-
D	FG (Frame ground)		--

Shaft End Specifications for SGMGH/SGMSH/SGMDH Servomotors

SGM□H - □□□□□□□□

Shaft End Specification

- 2 Straight, without key (standard)
- 3 Tapered 1/10, with parallel key (semi-standard)
(Key slot is JISB1301-1976 high precision SGMG Series is compatible with USAGED Series)
- 5 Tapered 1/10, with half-moon key (semi-standard)
Set only for SGMG-05/09 Half-moon key is JISB1302)
- 6 Straight, with key and tap (one location) (semi-standard)
(Key slot is JISB1301-1976 high precision Key slot tolerance is JISB1301 Both key and tap are included)

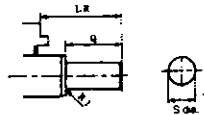

Figure 4.17 Shaft End Specification 2. Straight, without Key

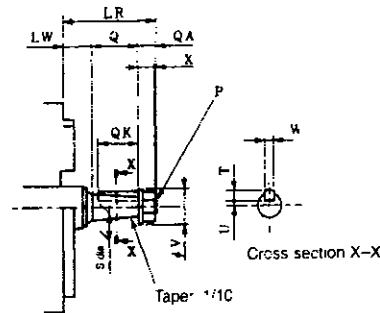

Figure 4 18 Shaft End Specification 3· Tapered 1/10, with Parallel Key

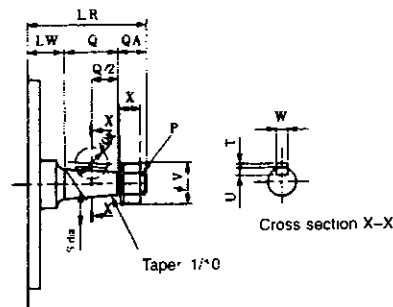

Figure 4 19 Shaft End Specification 5: Tapered 1/10, with Half-moon Key

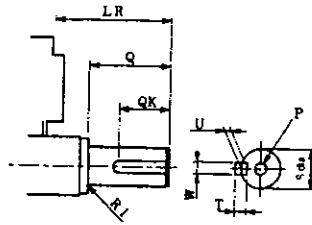

Figure 4.20 Shaft End Specification 6: Straight, with Key and Tap

#	Specification	Model															
		SGMSH-					SGMGH-						SGMDH-				
		10	15	20	30	40	50	03B	06B	09B	12B	20B	30B	40B	22	32	40
						05A	09A	13A	20A	30A	44A	55A					
2	Straight	LR	45 (1 77)		63 (2 48)		58 (2 28)			79 (3 11)			113 (4 45)		55 (2 17)	65 (2 56)	
		Q	40 (1 57)		55 (2 17)		40 (1 57)			76 (2 99)			110 (4 33)		50 (1 97)	60 (2 36)	
		S	$24 - \begin{matrix} 0 \\ 0.013 \\ 0 \end{matrix}$ $\left(\begin{matrix} 0.94 \\ -0.00258 \end{matrix} \right)$		$28 - \begin{matrix} 0 \\ 0.013 \\ 0 \end{matrix}$ $\left(\begin{matrix} 1.10 \\ -0.00058 \end{matrix} \right)$		$19 - \begin{matrix} 0 \\ 0.013 \\ 0 \end{matrix}$ $\left(\begin{matrix} 0.75 \\ -0.00058 \end{matrix} \right)$		$22 - \begin{matrix} 0 \\ 0.013 \\ 0 \end{matrix}$ $\left(\begin{matrix} 0.87 \\ -0.00058 \end{matrix} \right)$		$35 - \begin{matrix} 0.01 \\ 0 \\ 0 \end{matrix}$ $\left(\begin{matrix} 1.38 \\ +0.0004 \\ 0.8 \end{matrix} \right)$		$42 - \begin{matrix} 0 \\ 0.016 \\ 0 \end{matrix}$ $\left(\begin{matrix} 0.87 \\ -0.00058 \end{matrix} \right)$		$28 - \begin{matrix} 0 \\ 0.013 \\ 0 \end{matrix}$ $\left(\begin{matrix} 1.10 \\ -0.00058 \end{matrix} \right)$		$32 - \begin{matrix} 0 \\ 0.016 \\ 0 \end{matrix}$ $\left(\begin{matrix} 1.26 \\ -0.00068 \end{matrix} \right)$
3	Tapered 1/10, with parallel key	LR	70 (2 76)		80 (3 15)		58 (2 28)			102 (4 02)			132 (5 20)		-	-	
		LW	20 (0 79)					18 (0 71)			22 (0 87)			-	-		
		Q	36 (1 42)		42 (1 65)		28 (1 10)			58 (2 28)			82 (3 23)		-	-	
		QA	14 (0 55)		18 (0 71)		12 (0 47)			22 (0 87)			28 (1 10)		-	-	
		QK	32 (1 26)		36 (1 42)		25 (0 98)*1			50 (1 97)			70 (2 76)		-	-	
		X	12 5 (0 49)		16 (0 63)		10 3 (0 41)			19 2 (0 76)			23 (0 91)		-	-	
		S	24 (0 94)		28 (1 10)		16 (0 63)		19 (0 75)		32 (1 26)			42 (1 65)		-	-
		V	24 (0 94)		30 (1 18)		21 (0 83)			37 (1 46)			44 (1 73)		-	-	
		P	M12, P1 25		M16, P1 5		M10, P1 25			M20, P1 5			M24, P2 0		-	-	
		W	8 (0 31)					5 (0 20)			7 (0 28)			10 (0 39)		-	-
		T	7 (0 28)					5 (0 20)*2			7 (0 28)			8 (0 31)		-	-
		U	7 1 (0 28)		8 95 (0 35)		4 3*3 (0 17)		5 8 (0 23)		10 55 (0 42)			13 95 (0 55)		-	-



Servodrive Dimensional Drawings

4 1 6 SGMDH Servomotors

#	Specification	Model															
		SGMSH-					SGMGH-								SGMDH-		
		10	15	20	30	40	50	03B	06B	09B	12B	20B	30B	40B	22	32	40
						05A	09A	13A	20A	30A	44A	55A					
5	Tapered 1/10, with half-moon key	LR						58 (2 28)									
		LW						18 (0 71)									
		Q						28 (1 10)									
		QA						12 (0 47)									
		QK						16 (0 63)									
		X						10 3 (0 41)									
		S						16 (0 63)									
		V						21 (0 83)									
		P						M10, P1 25									
		W						5 (0 20)									
		T						2 (0 079)									
U						4 5 (0 18)											
6	Straight, with key and tap	LR	45 (1 77)		63 (2 48)			58 (2 28)		79 (3 11)		113 (4 45)		55 (2 17)		65 (2 56)	
		Q	40 (1 57)		55 (2 17)			40 (1 57)		76 (2 99)		110 (4 33)		50 (1 97)		60 (2 36)	
		QK	32 (1 26)		50 (1 97)			25 (0 98)		60 (2 36)		90 (3 54)		45 (1 77)		50 (1 97)	
		S	$24 - \begin{matrix} 0 \\ 0 013 \end{matrix}$ $\begin{pmatrix} 0 94 & -0 00058 \end{pmatrix}$		$28 - \begin{matrix} 0 \\ 0 013 \end{matrix}$ $\begin{pmatrix} 1 10 & -0 00058 \end{pmatrix}$			$19 - \begin{matrix} 0 \\ 0 013 \end{matrix}$ $\begin{pmatrix} 0 75 & -0 00058 \end{pmatrix}$	$22 - \begin{matrix} 0 \\ 0 013 \end{matrix}$ $\begin{pmatrix} 0 87 & -0 00058 \end{pmatrix}$		$35 + \begin{matrix} 0 01 \\ 0 \end{matrix}$ $\begin{pmatrix} 1 38 & -0 00004 \\ & 08 \end{pmatrix}$		$42 - \begin{matrix} 0 \\ 0 016 \end{matrix}$ $\begin{pmatrix} 0 87 & -0 00058 \end{pmatrix}$		$28 - \begin{matrix} 0 \\ 0 013 \end{matrix}$ $\begin{pmatrix} 1 10 & -0 00058 \end{pmatrix}$		$32 - \begin{matrix} 0 \\ 0 016 \end{matrix}$ $\begin{pmatrix} 1 26 & -0 0006 \end{pmatrix}$
		W		8 (0 31)			5 (0 20)	6 (0 24)		10 (0 39)		12 (0 47)		8 (0 31)		10 (0 39)	
		T		7 (0 28)			5 (0 20)	6 (0 24)		8 (0 31)				7 (0 28)		8 (0 31)	
		U		4 (0 16)			3 (0 12)	3 5 (0 14)		5 (0 20)				4 (0 16)		5 (0 20)	
		P		M8 screws, depth 16				M5 screws, depth 12				M12 screws, depth 12		M16 screws, depth 32		M8 screws, depth 16	

- * 1 QK will be 16 for the SGMGH-05A/09A if mounting replacement is not specified
- * 2 T will be 2 for the SGMGH-05A/09A if mounting replacement is not specified
- * 3 U will be 4 5 for the SGMGH-05A/09A if mounting replacement is not specified

4.2 Servopack Dimensional Drawings

This section provides dimensional drawings of the SGDM Servopack according to the following mounting methods

■ Base Mounted

Single-phase	For 200 V	30 to 200 W (SGDM-A3AD to -02AD, -A3ADA to -02ADA)
	For 100 V	30 to 100 W (SGDM-A3BD to -01BD, -A3BDA to -01BDA)
Single-phase	For 200 V	400 W (SGDM-04AD, -04ADA)
	For 100 V	200 W (SGDM-02BD, -02BDA)
Three-phase	For 200 V	0.5 to 1.0 kW (SGDM-05AD to -10AD, -05ADA to -10ADA)
Three-phase	For 200 V	1.5 kW (SGDM-15AD, -15ADA)
Three-phase	For 200 V	2.0, 3.0 kW (SGDM-20AD, -30AD, -20ADA, -30ADA)
Three-phase	For 200 V	5.0 kW (SGDM-50ADA)
Three-phase	For 200 V	6.0, 7.5 kW (SGDM-60ADA, -75ADA)
Three-phase	For 200 V	11, 15 kW (SGDM-1AADA, -1EADA)

■ Rack Mounted

Single-phase	For 200 V	30 to 200 W (SGDM-A3AD-R to -02AD-R, -A3ADA-R to -02ADA-R)
	For 100 V	30 to 100 W (SGDM-A3BD-R to -01BD-R, -A3BDA-R to -01BDA-R)
Single-phase	For 200 V	400 W (SGDM-04AD-R, -04ADA-R)
	For 100 V	200 W (SGDM-02BD-R, -02BDA-R)
Three-phase	For 200 V	0.5 to 1.0 kW (SGDM-05AD-R to -10AD-R, -05ADA-R to -10ADA-R)
Three-phase	For 200 V	1.5 kW (SGDM-15AD-R, -15ADA-R)
Three-phase	For 200 V	2.0, 3.0 kW (SGDM-20AD-R, -30AD-R, -20ADA-R, -30ADA-R)
Three-phase	For 200 V	5.0 kW (SGDM-50ADA-R)

■ Duct Ventilated

Three-phase	For 200 V	6.0, 7.5 kW (SGDM-60ADA-P, -75ADA-P)
Three-phase	For 200 V	11, 15 kW (SGDM-1AADA-P, -1EADA-P)

4.2.1 Base-mounted Servopacks

- SGDM-A3AD to -02AD, -A3DA to -02ADA (Single-phase 200 V, 3 to 200 W) and SGDM-A3BD to -01BD, -A3BDA to -01BDA (Single-phase 100 V, 30 to 100 W)

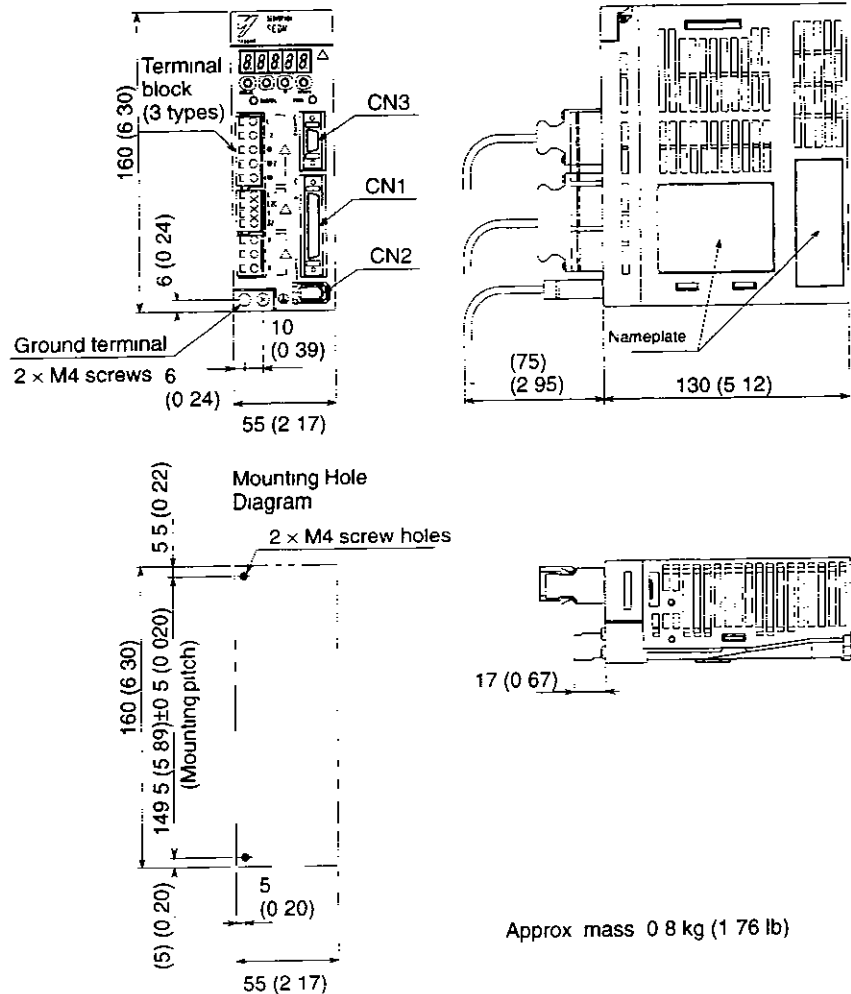

The same Servopack Connector is used for all the models with different power capacities

Connector Symbol	Servopack Connector Model	Manufacturer
CN1	I0250-52A2JL	Sumitomo 3M Co., Ltd
CN2	53460-0611	Molex Japan Co., Ltd
CN3	I0214-52A2JL	Sumitomo 3M Co., Ltd

Note Use the items above or the equivalent

■ SGDM-05AD to -10AD, -05ADA to -10ADA (Three-phase 200 V, 0. to 1.0 kW)

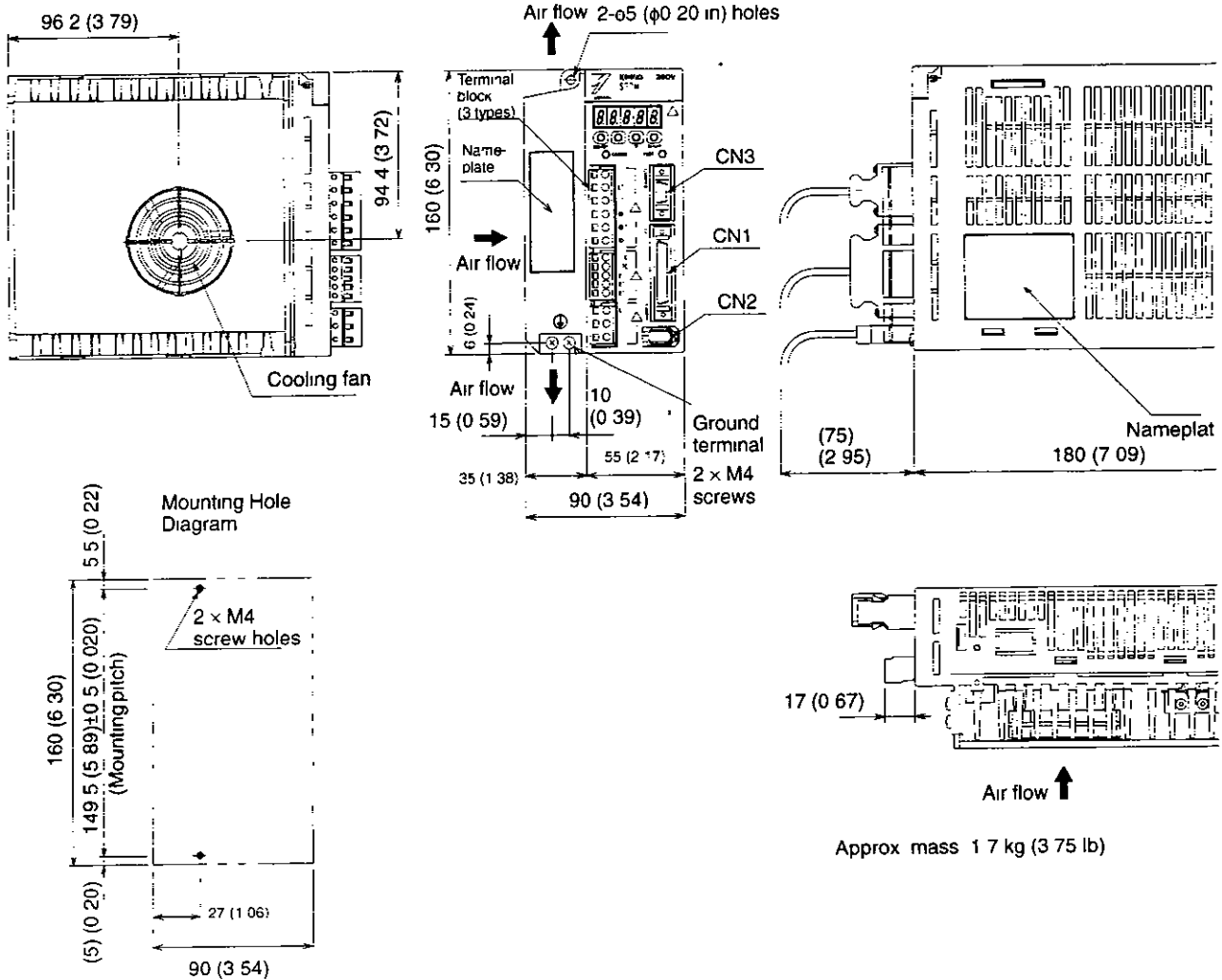

Approx mass 1.7 kg (3.75 lb)

■ SGDM-15AD, -15ADA (Three-phase 200 V, 1.5 kW)

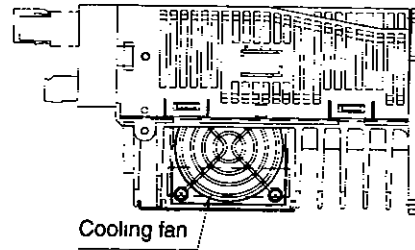
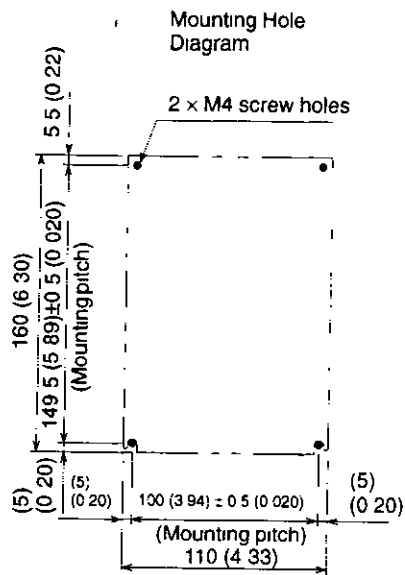
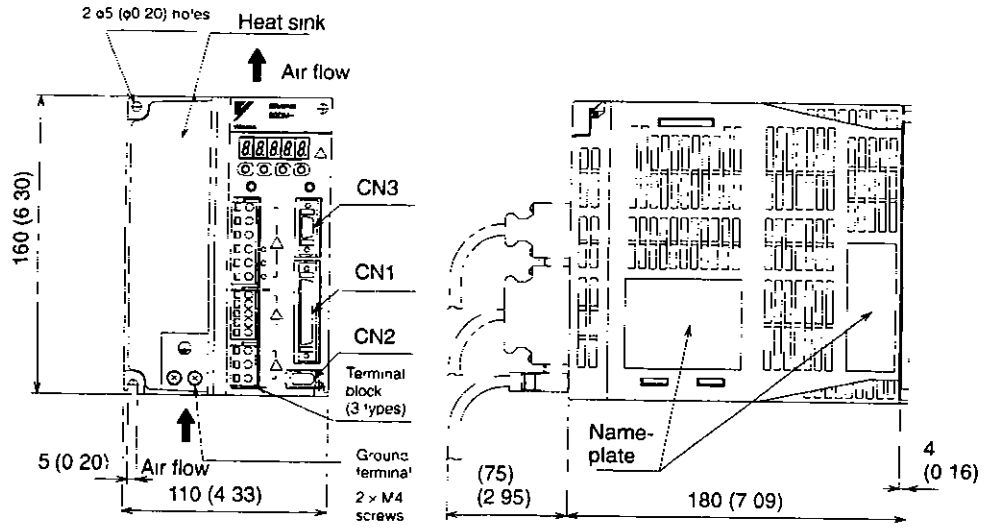

Approx mass 2.8 kg (6.17 lb)



■ **SGDM-20AD, -30AD, -20ADA, -30ADA (Three-phase 200V, 2.0kW, 3.0 kW)**

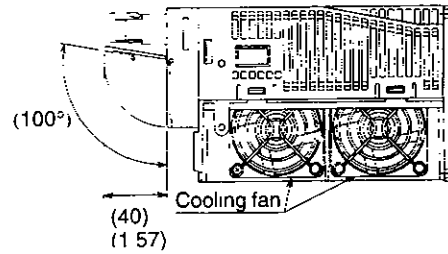
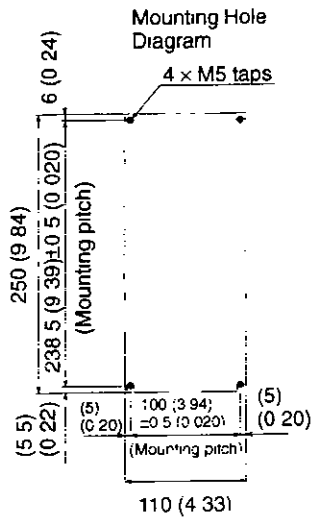
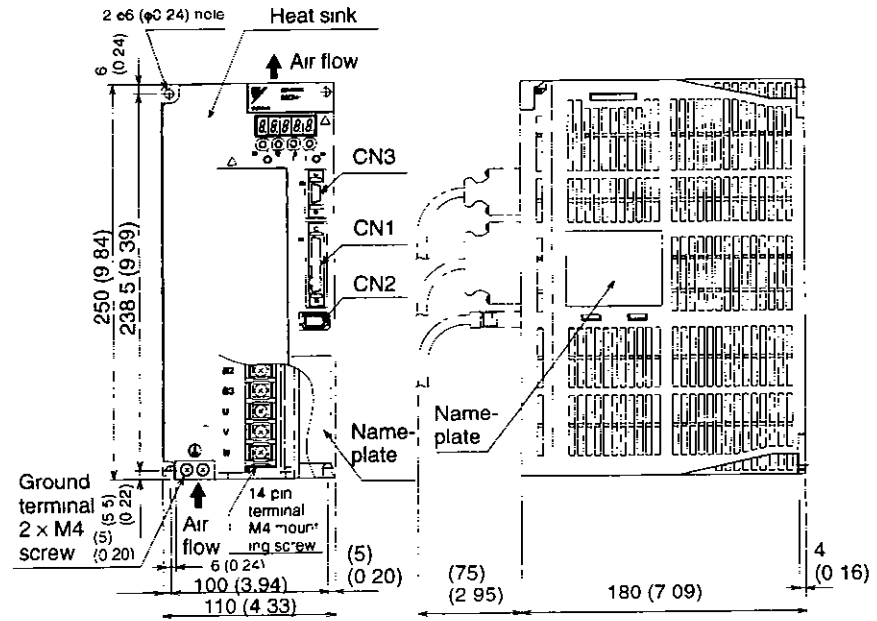

Approx mass 3.8 kg (8.38 lb)

■ SGDM-50ADA (Three-phase 200V, 5.0 kW)

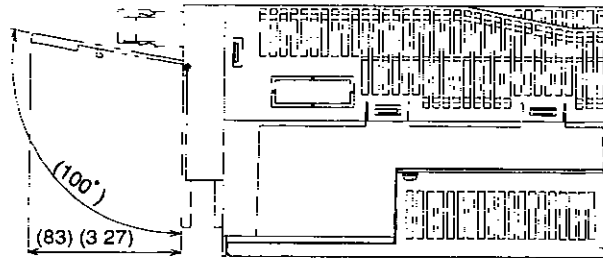
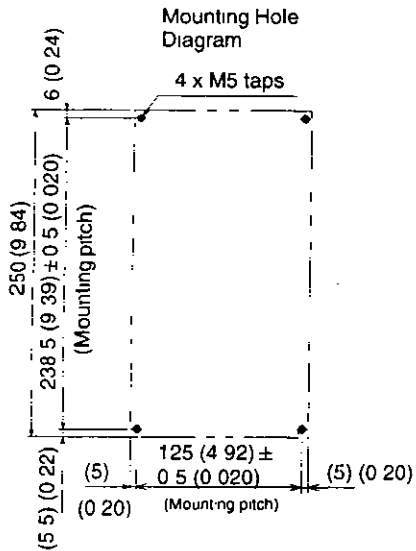
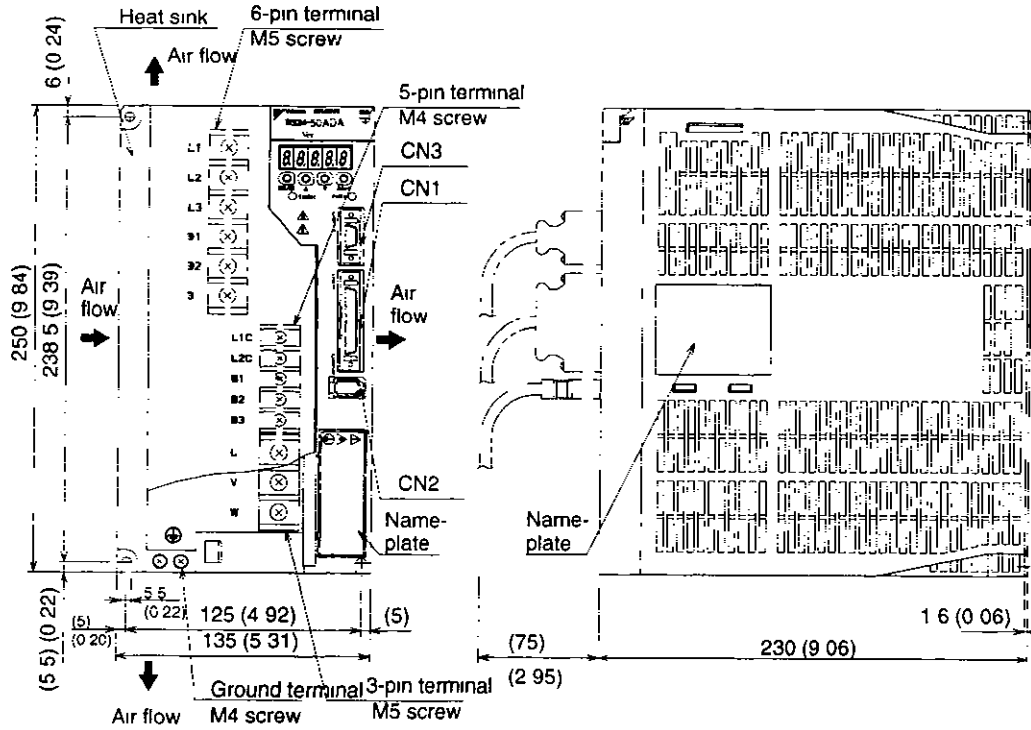

Approx mass 5 5 kg (12 1 lb)

■ SGDM-1AADA, -1EADA (Three-phase 200 V, 11 kW, 15 kW)

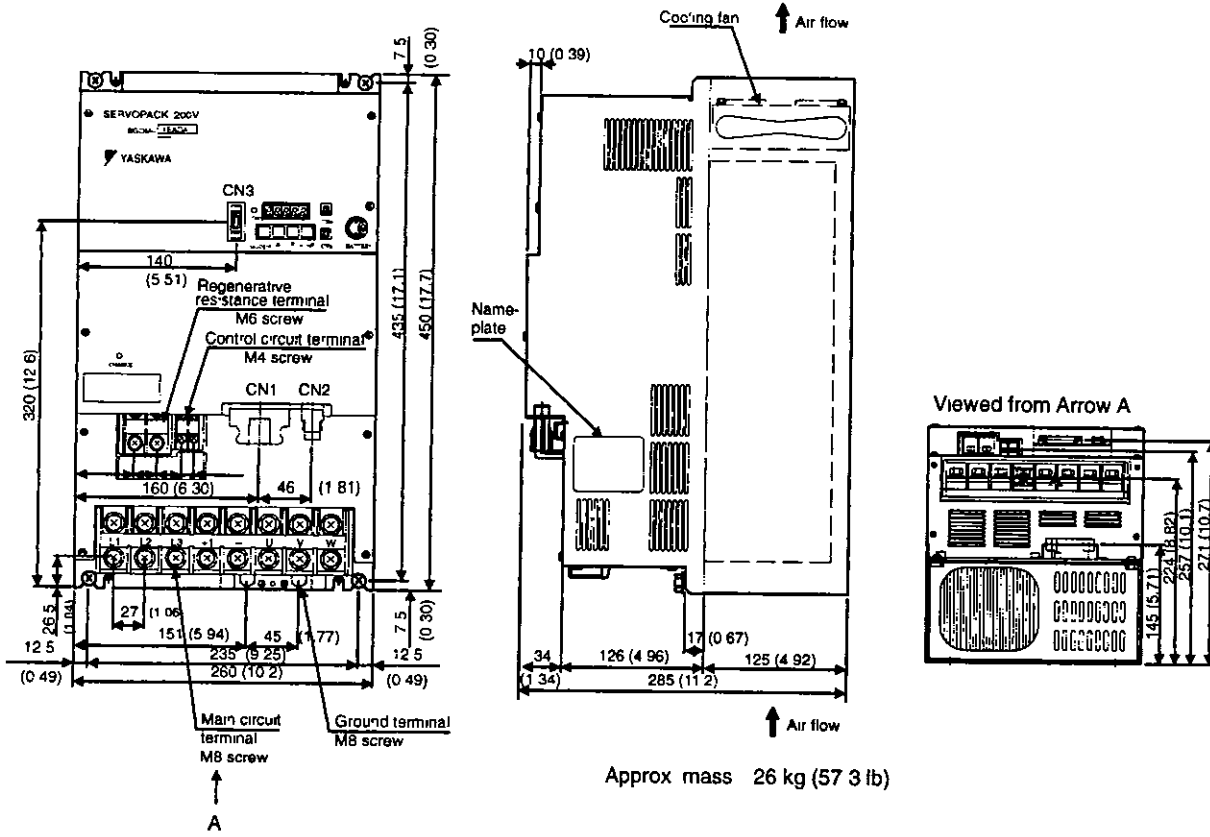

4.2.2 Rack-mounted Servopacks

- SGDM-A3AD-R to -02AD-R, -A3ADA-R to -02ADA-R (Single-phase 200 V, 30 to 200 W) and SGDM-A3BD-R to -01BD-R, -A3BDA-R to -01BDA-R (Single-phase 100 V, 30 to 100 W)

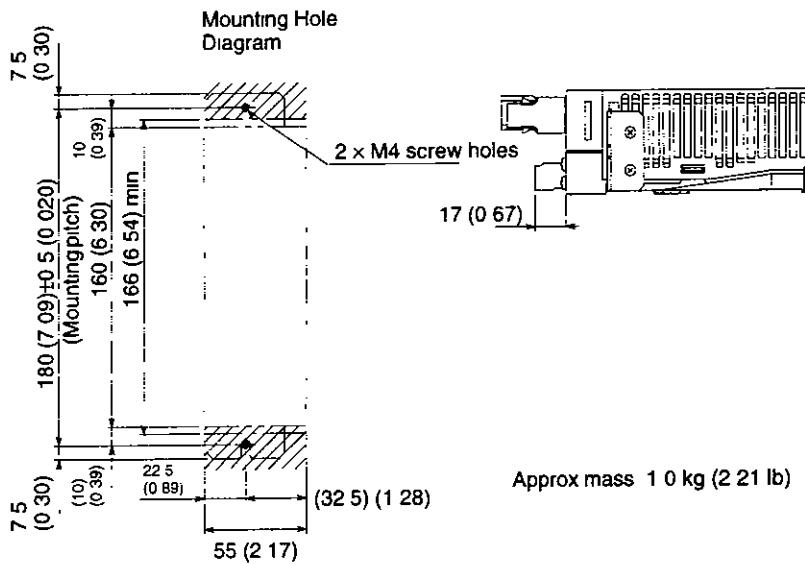
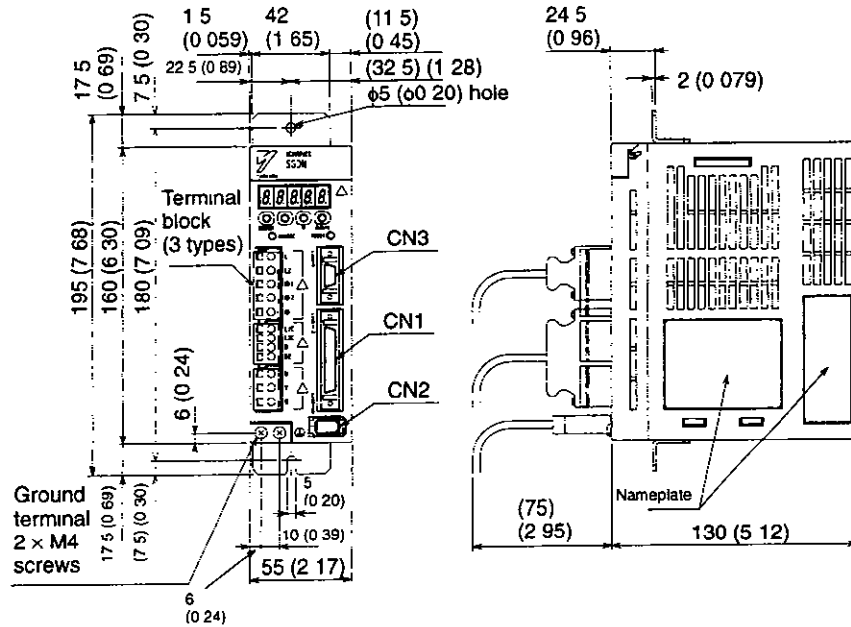

■ SGDM-05AD-R to -10AD-R, -05ADA-R to -10ADA-R (Three-phase 200 V, 0.5 to 1.0 kW)

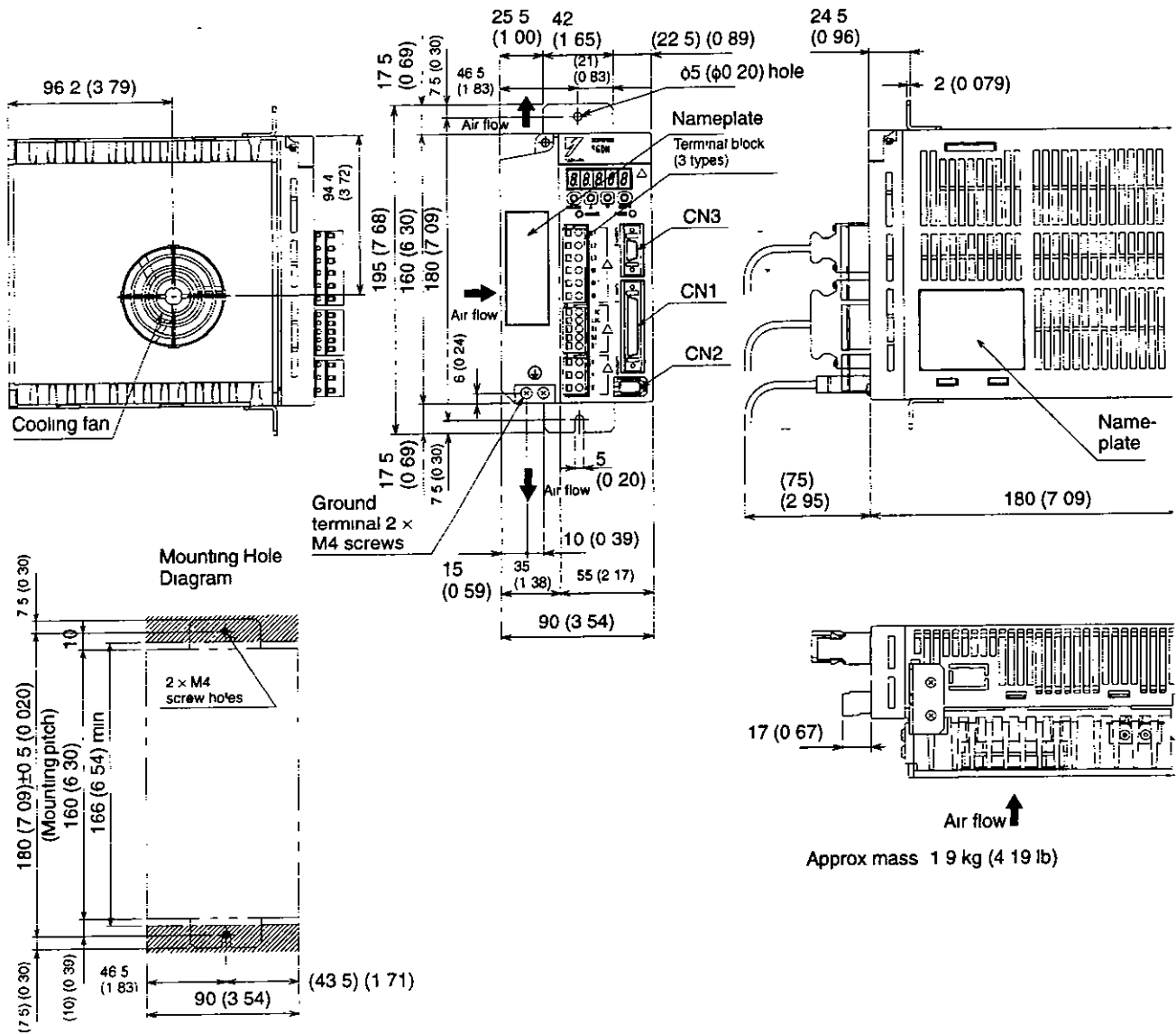

■ SGDM-15AD-R, -15ADA-R (Three-phase 200 V, 1.5 kW)

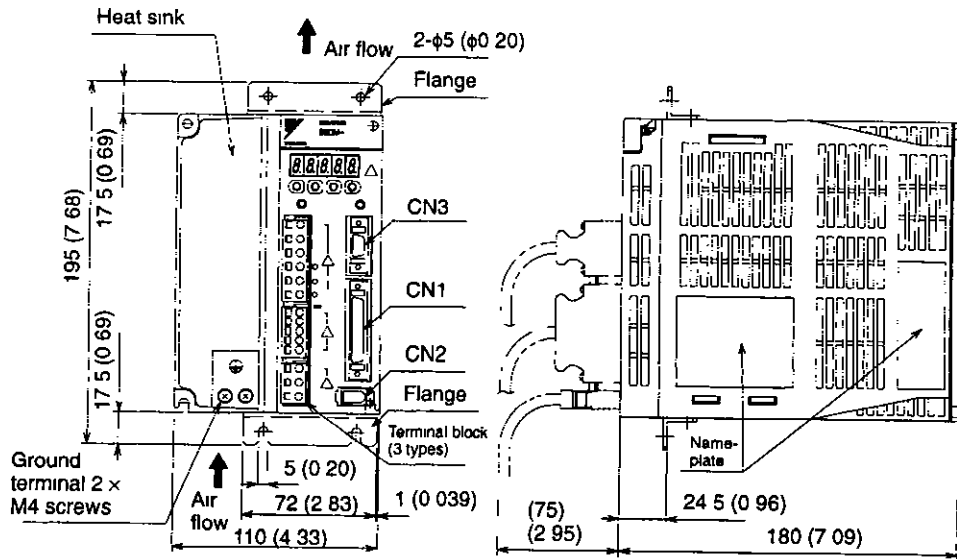

Mounting Hole Diagram

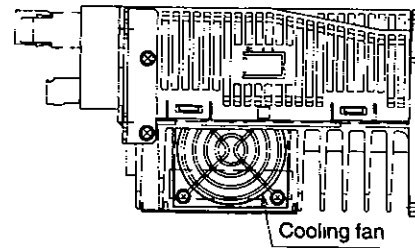
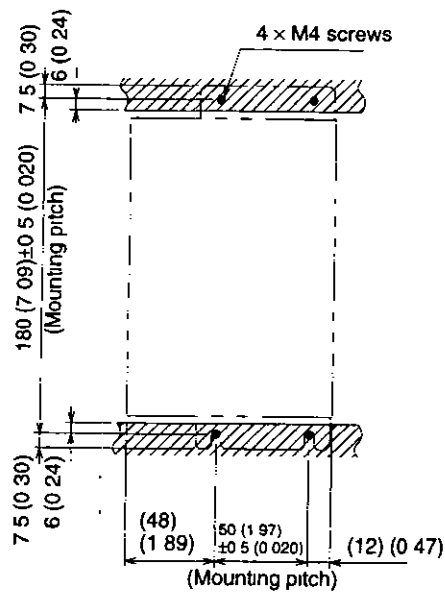

Approx mass 3 0 kg (6 61 lb)



■ SGDM-20AD-R, -30AD-R, -20ADA-R, -30ADA-R (Three-phase 200 V, 2.0 kW, 3.0 kW)

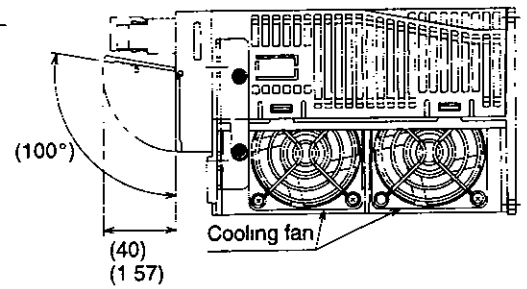
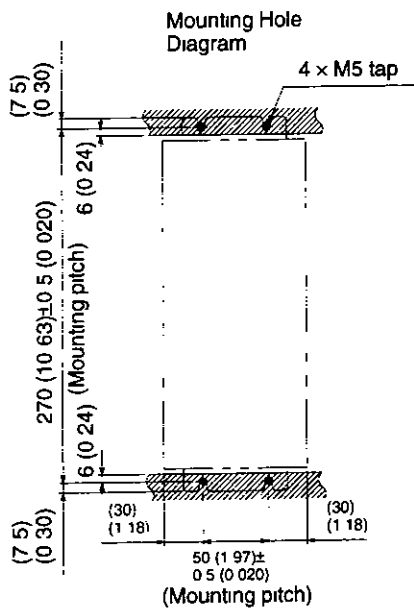
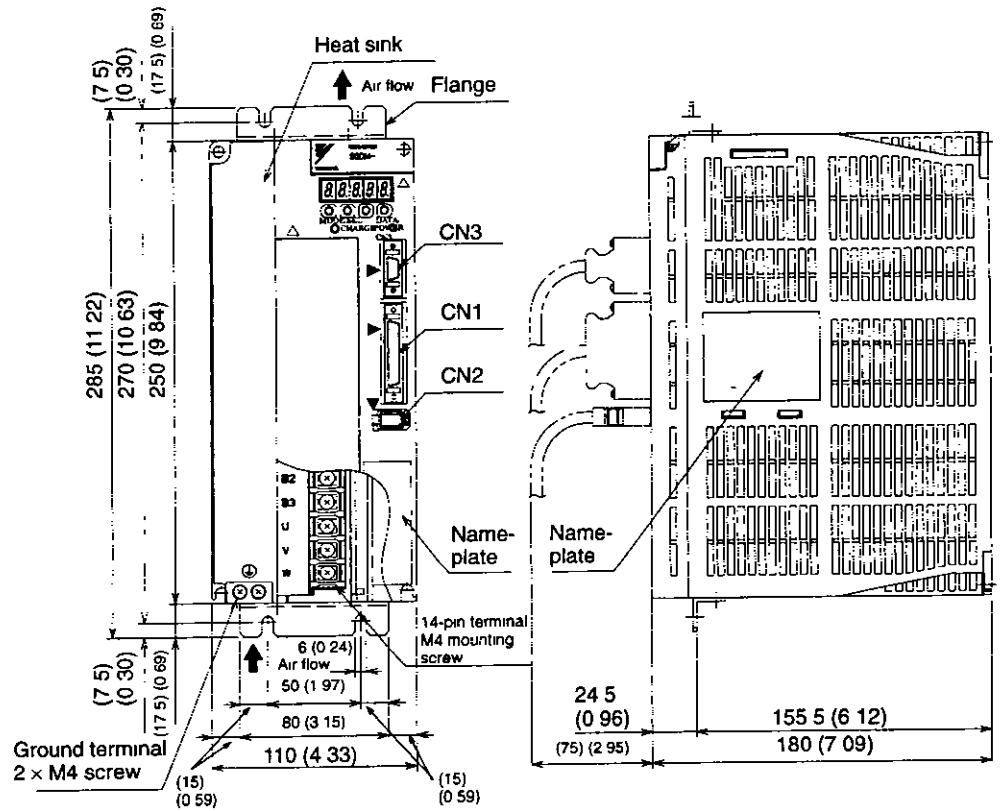

Approx mass 4 5 kg (9 92 lb)

■ SGDM-1AADA-P, -1EADA-P (Three-phase 200 V, 11 kW, 15 kW)

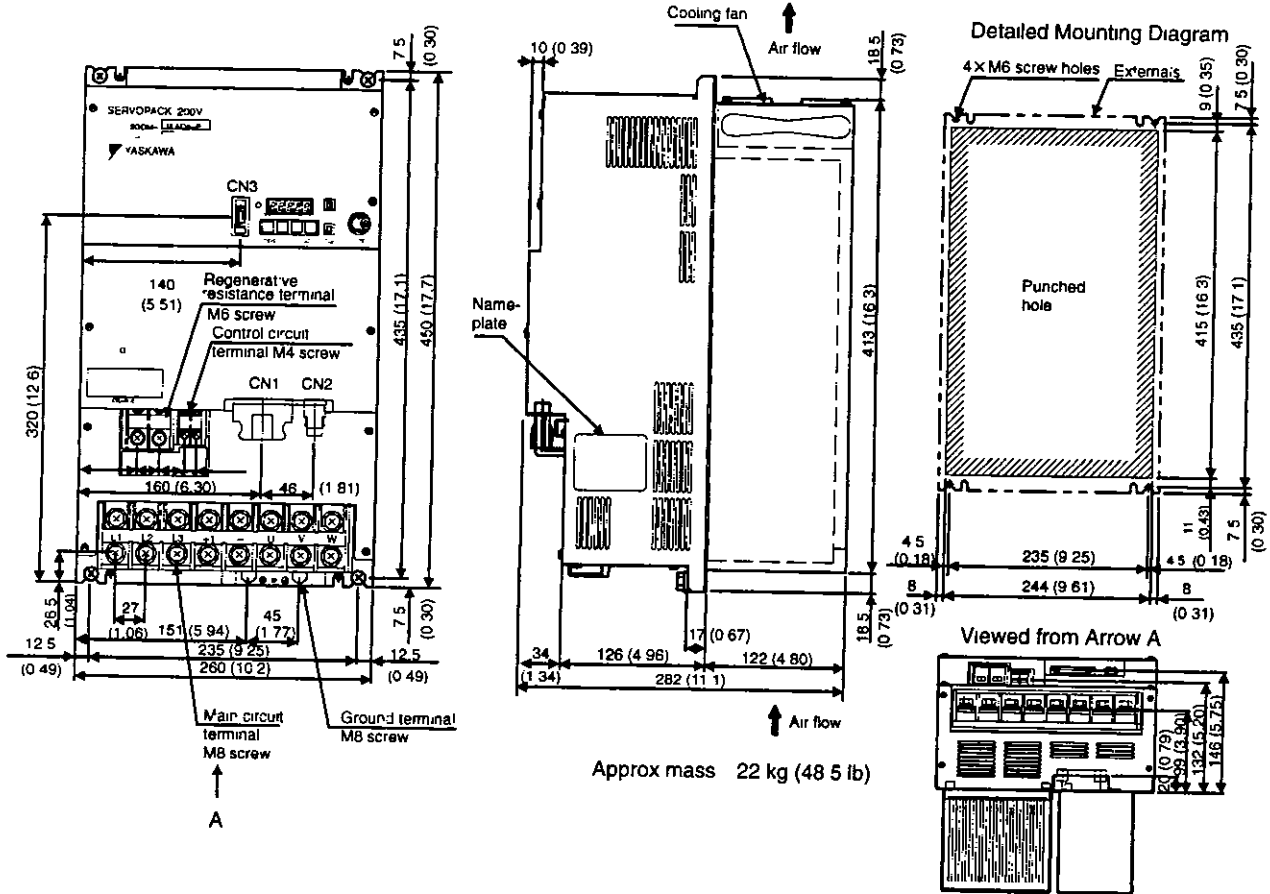



5

Specifications and Dimensional Drawings for Peripheral Devices

This chapter provides specifications and dimensional drawings for peripheral devices required in a Σ -II Series Servo System. The procedure for selecting peripheral devices is given in chapter 1.3 *Selecting Peripheral Devices*.

5.1 Cable Specifications and Peripheral	
Devices	5 -2
5.1.1 Cable Specifications	5 -2
5.1.2 Peripheral Device Types and Capacities	5 -6
5.2 Special Options	5 -9
5.2.1 Digital Operator	5 -9
5.2.2 Cables	5 -11
5.2.3 Connectors	5 -18
5.2.4 External Regenerative Resistors	5 -37
5.2.5 Regenerative Resistor Unit	5 -39
5.2.6 DC Reactors for Power Supplies Designed for Minimum Harmonics	5 -41
5.2.7 Brake Power Supplies	5 -42
5.2.8 Absolute Encoder Battery	5 -44
5.2.9 Connector Terminal Block Converter Unit	5 -45
5.2.10 Encoder Signal Converter Unit	5 -47
5.2.11 Cables for Connecting PCs to a Servopack	5 -48
5.2.12 Personal Computer Monitoring Software	5 -52
5.3 Peripheral Devices	5 -53
5.3.1 Molded-case Circuit Breaker (MCCB)	5 -53
5.3.2 Noise Filter	5 -53
5.3.3 Magnetic Contactor	5 -55
5.3.4 Surge Suppressor	5 -57
5.3.5 Variable Resistor for Speed Setting	5 -57



5.1 Cable Specifications and Peripheral Devices

Ratings and specifications for peripheral devices as well as cable specifications for Servopacks are summarized in *Table 5 1* to *Table 5 4*

 CAUTION
Wiring Precautions
<ul style="list-style-type: none"> • Do not bundle or run power and signal lines together in the same duct Keep power and signal lines at least 30 cm (11 81 in) apart • Use twisted-pair wires or shielded multi-core twisted-pair wires for signal and encoder (PG) feedback lines • The maximum lengths for signal lines are as follows <ul style="list-style-type: none"> • Maximum of 3 m (9 84 ft) for reference input lines • Maximum of 20 m (65 6 ft) for PG feedback lines • Use a cable with 50 m (164 0 ft) specifications for distances over 20 m (65 6 ft)

5.1.1 Cable Specifications

Table 5 1 provides wire size specifications

Table 5.1 Servopack Wire Sizes

External Terminal Name			SGDM- Terminal Symbol	Wire Size [mm ² (in ²)]					
				A3AD	A5AD	01AD	02AD	04AD	
				A3ADA	A5ADA	01ADA	02ADA	04ADA	
For 200 V	Online terminals	Main circuit power input terminals	L1, L2 (Single phase)	AWG16 [HIV 1 25 (0 002)]					AWG14 [HIV 2 0 (0 003)]
		Servomotor con- nection terminals	U, V, W	AWG16 [HIV 1 25 (0 002)]					
		Control power sup- ply input terminals	L1C, L2C	AWG16 [HIV 1 25 (0 002)]					
	Offline terminals	Control I/O signal connector	CN1	Twisted-pair or shielded twisted-pair wires Core wire at least 0 12 mm ² (0 0002 in ²), tinned, annealed copper twisted wires					
		PG signal connector	CN2	Finished cable dimensions max ϕ 16 mm (0 63 in) for CN1 and max ϕ 6 8 mm (0 27 in) for CN2					
		Ground terminal		AWG14 [HIV 2 0 (0 003)] min					

External Terminal Name			SGDM- Terminal Symbol		Wire Size Examples [mm ² (in ²)]					
					05AD	08AD	10AD	15AD	20AD	30AD
			05ADA	08ADA	10ADA	15ADA	20ADA	30ADA		
For 200 V	Online terminals	Main circuit power input terminals	L1, L2, L3 (Three phase)	AWG14 [HIV 2 0 (0 003)]			AWG12 [HIV 3 5 (0 005)]			
		Servomotor connection terminals	U, V, W	AWG14 [HIV 2 0 (0 003)]		AWG12 [HIV 3 5 (0 005)]		AWG10 [HIV 5 5 (0 009)]		
		Control power supply input terminal	L1C, L2C	AWG16 [HIV 1 25 (0 002)]						
	Offline terminals	Control I/O signal connector	CN1	Twisted-pair or shielded twisted-pair wires Core wire at least 0.12 mm ² (0.0002 in ²), tinned, annealed copper twisted wires Finished cable dimensions max ϕ 16 mm (0.63 in) for CN1 and max ϕ 6.8 mm (0.27 in) for CN2						
		PG signal connector	CN2							
		Ground terminal		AWG14 [HIV 2 0 (0 003)] min						

External Terminal Name			SGDM- Terminal Symbol		Wire Size Examples [mm ² (in ²)]				
					50ADA	60ADA	75ADA	1AADA	1EADA
			For 200 V	Online terminals	Main circuit power input terminals	L1, L2, L3 (Three phase)	AWG10 [HIV 5 5 (0 009)]	AWG8 [HIV 8 (0 012)]	AWG6 [HIV 14 (0 022)]
Servomotor connection terminals	U, V, W	AWG8 [HIV 8 (0 012)]			AWG6 [HIV 14 (0 022)]		AWG4 [HIV 22 (0 034)]		
Control power supply input terminal	L1C, L2C	AWG16 [HIV 1 25 (0 002)]							
Offline terminals	Control I/O signal connector	CN1		Twisted-pair or shielded twisted-pair wires Core wire at least 0.12 mm ² (0.0002 in ²), tinned, annealed copper twisted wires Finished cable dimensions max ϕ 16 mm (0.63 in) for CN1 and max ϕ 6.8 mm (0.27 in) for CN2					
	PG signal connector	CN2							
	Ground terminal			AWG14 [HIV 2 0 (0 003)] min					



External Terminal Name			SGDM- Terminal Symbol	Wire Size Examples [mm ² (in ²)]				
				A3BD	A5BD	01BD	02BD	
				A3BDA	A5BDA	01BDA	02BDA	
For 100 V	Online terminals	Main circuit power input terminals	L1, L2	AWG16 [HIV 1 25 (0 002)]				AWG14 [HIV 2 0 (0 003)]
		Servomotor connection terminals	U, V, W	AWG16 [HIV 1 25 (0 002)]				
		Control power supply input terminal	L1C, L2C	AWG16 [HIV 1 25 (0 002)]				
	Offline terminals	Control I/O signal connector	CN1	Twisted-pair or shielded twisted-pair wires Core wire at least 0.12 mm ² (0.0002 in ²), tinned, annealed copper twisted wires				
		PG signal connector	CN2	Finished cable dimensions max ϕ 16 mm (0.63 in) for CN1 and max ϕ 6.8 mm (0.27 in) for CN2				
		Ground terminal		AWG14 [HIV 2 0 (0 003)] min				

- Note 1.** Wire sizes were selected for three cables per bundle at 40°C ambient temperature with the rated current
2. Use cable with a minimum withstand voltage of 600 V for main circuits
 3. If cables are bundled in PVC or metal ducts, consider the reduction ratio of the allowable current
 4. Use heat-resistant cable under high ambient or panel temperatures where normal vinyl cable will rapidly deteriorate

Table 5 2 shows types of cables and must be used in conjunction with Table 5 1

Table 5 2 Cable Types

Cable Types		Allowable Conductor Temperature °C
Symbol	Name	
PVC	Normal vinyl cable	–
IV	600-V vinyl cable	60
HIV	Temperature-resistant vinyl cable	75

Table 5 3 shows appropriate cables for CN1 and CN2 Servopack connectors

Wire sizes were selected for three cables per bundle at 40°C ambient temperature with the rated current

Table 5.3 Cables for CN1 and CN2 Connectors

Connector Name and Signal		Item	Specification
Control I/O Signal Connector	CN1	Cable	Use twisted-pair or shielded twisted-pair wire
		Applicable wire	AWG24 [0.2 mm ² (0.0003 in ²)], AWG26 [0.12 mm ² (0.0002 in ²)], AWG28 [0.08 mm ² (0.0001 in ²)], AWG30 [0.05 mm ² (0.00008 in ²)]
		Finished cable dimension	φ16.0 mm (φ0.63 in) MAX
PG Signal Connector	CN2	Cable	Use Yaskawa cable, or shielded twisted-pair wire if Yaskawa cable is not used
		Applicable wire	AWG24 [0.2 mm ² (0.0003 in ²)], AWG26 [0.12 mm ² (0.0002 in ²)], AWG28 [0.08 mm ² (0.0001 in ²)], AWG30 [0.05 mm ² (0.00008 in ²)] Use AWG22 [0.33 mm ² (0.001 in ²)] for the encoder power supply and AWG26 [0.12 mm ² (0.0002 in ²)] for other signals. These conditions permit wiring distances up to 20 m (65.6 ft)
		Finished cable dimension	φ6.8 mm (φ0.27 in) MAX



5.1.2 Peripheral Device Types and Capacities

Table 5.4 shows Servopack peripheral device types and capacities

Table 5.4 Peripheral Device Types and Capacities

Main Circuit Power Supply	Model		Applicable Servomotor	Power Supply Capacity per Servopack (kVA)	MCCB or Fuse Capacity *1 (A _{rms})	Recommended Noise Filter *2		Magnetic Contactor
	Capacity (kW)	SGDM-				Model	Specifications	
Single-Phase 200 V	0.03	A3AD	SGMAH-A3A	0.20	4	SUP-P5H-EPR	Single-phase 250 VAC 5 A	HI-11J (20 A) or the equivalent
		A3ADA						
	0.05	A5AD	SGMAH-A5A	0.25				
		A5ADA						
	0.10	01AD	SGMAH-01A	0.40				
		01ADA	SGMPH-01A					
	0.20	02AD	SGMAH-02A	0.75				
		02ADA	SGMPH-02A					
0.40	04AD	SGMAH-04A	1.2					
	04ADA	SGMPH-04A						

Main Circuit Power Supply	Model		Applicable Servomotor	Power Supply Capacity per Servopack (kVA)	MCCB or Fuse Capacity *1 (Arms)	Recommended Noise Filter *2		Magnetic Contactor								
	Capacity (kW)	SGDM-				Model	Specifications									
Three-Phase 200 V	0.50	05AD 05ADA	SGMGH-05A□A	1.4	4	LF-3200	Three-phase 250 VAC 20 A	HI-11J (20 A) or the equivalent								
			SGMGH-03A□B													
	0.75	08AD 08ADA	SGMAH-08A	1.9	7			LF-3200	Three-phase 250 VAC 20 A	HI-15J (35 A) or the equivalent						
			SGMPH-08A													
			SGMGH-06A□B													
	1.0	10AD 10ADA	SGMGH-09A□A	2.3	10					LF-3200	Three-phase 250 VAC 20 A	HI-15J (35 A) or the equivalent				
			SGMGH-09A□B													
			SGMSH-10A													
	1.5	15AD 15ADA	SGMPH-15A	3.2	10							LF-3200	Three-phase 250 VAC 20 A	HI-15J (35 A) or the equivalent		
			SGMGH-13A□A													
			SGMGH-12A□B													
			SGMSH-15A													
	2.0	20AD 20ADA	SGMGH-20A□A	4.3	13									LF-3200	Three-phase 250 VAC 20 A	HI-20J (35 A) or the equivalent
			SGMGH-20A□B													
			SGMSH-20A													
3.0	30AD 30ADA	SGMDH-22A	5.9	17	LF-3300	Three-phase 250 VAC 30 A	HI-20J (35 A) or the equivalent									
		SGMGH-30A□A														
		SGMGH-30A□B														
		SGMSH-30A														
5.0	50ADA	SGMDH-32A	7.5	28			LF-3400	Three-phase 250 VAC 40 A	HI-25J (50 A) or the equivalent							
		SGMDH-40A														
		SGMSH-40A														
		SGMGH-44A□A														
		SGMGH-40A□B														
		SGMSH-50A														
6.0	60ADA	SGMGH-55A□A	12.5	32					LF-3500	Three-phase 250 VAC 50 A	HI-25J (50 A) or the equivalent					
		SGMGH-55A□B														
7.5	75ADA	SGMGH-75A□A	15.5	41							LF-3600	Three-phase 250 VAC 60 A	HI-35J (65 A) or the equivalent			
11.0	1AADA	SGMGH-1AA	22.7	60							FS5559-150-35	Three-phase 480 VAC 150 A	HI-50J (75 A) or the equivalent			
15.0	1EADA	SGMGH-1EA	30.9	81									HI-65J (100 A) or the equivalent			

Specifications and Dimensional Drawings for Peripheral Devices

5.1.2 Peripheral Device Types and Capacities

Main Circuit Power Supply	Model		Applicable Servomotor	Power Supply Capacity per Servopack (kVA)	MCCB or Fuse Capacity *1 (Arms)	Recommended Noise Filter *2		Magnetic Contactor
	Capacity (kW)	SGDM-				Model	Specifications	
Single-phase 100V	0.03	A3BD	SGMAH-A3B	0.15	4	SUP-P5H-EPR	Single-phase AC 250 V 5 A	HI-11J (20 A) or the equivalent
		A3BDA						
	0.05	A5BD	SGMAH-A5B	0.25	4	SUP-P5H-EPR	Single-phase AC 250 V 5 A	
		A5BDA						
0.10	01BD	SGMAH-01B	0.40	4	SUP-P5H-EPR	Single-phase AC 250 V 5 A		
	01BDA	SGMPH-01B						
0.20	02BD	SGMAH-02B	0.60	6	SUP-P8H-EPR	Single-phase AC 250 V 8 A		
	02BDA	SGMPH-02B						

* 1. Braking characteristics at 25°C: 200% for 2 s min, 700% for 0.01 s min

* 2. The SUP-P□H-EPR noise filter is manufactured by Okaya Electric Co. The LF3□00 noise filter is manufactured by Tokin Corp.

5.2 Special Options

Special options are not provided as standard specifications, some special options are manufactured by Yaskawa. Others must be purchased from the manufacturer of the option.

5.2.1 Digital Operator

The SGDM Servopack has Digital Operator functions built in, but a hand-held Digital Operator can be connected to the Servopack just as with conventional Σ -Series Servopacks.

The cable section specifications are different from those of conventional hand-held Digital Operators (JUSP-OP02A-1). A conventional unit can be used simply by replacing the cable section.

Figure 5.1 shows the Digital Operator (unit + cable) and cable configuration.

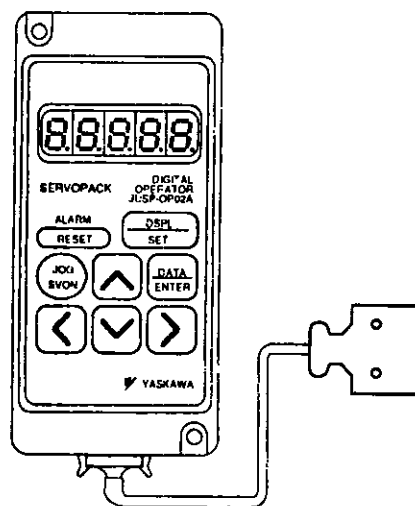

Digital Operator configuration
(unit + 1-m (3.28-ft) cable)
JUSP-OP02A-2

Figure 5.1 Digital Operator



Table 5 5 and Figure 5 2 provide cable specifications

Table 5.5 Cable Models and Lengths

Cable Models	Length (L)
JZSP-CMS00-1	1 m (3 28 ft)
JZSP-CMS00-2	1 5 m (4 92 ft)
JZSP-CMS00-3	2 m (6 56 ft)

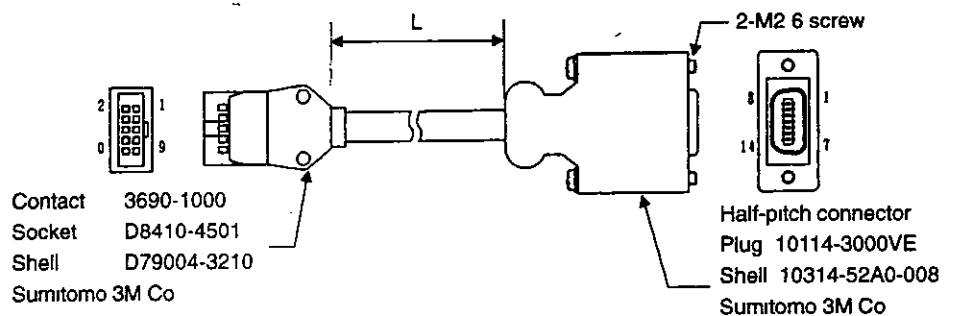

Figure 5 2 Cable Diagram

Figure 5 3 shows the connection circuits

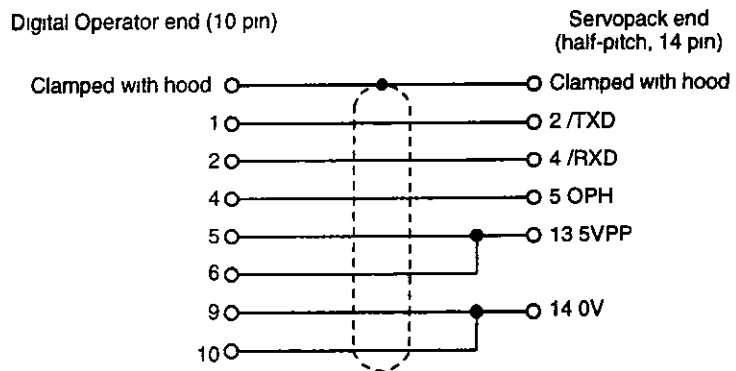

Figure 5.3 Digital Operator Connection Circuits

5.2.2 Cables

■ Servomotor Cables

See section 5.1 for more details on Servomotor Cables. Customers must select and purchase the cables separately according to their specifications.

Purchase one of the following cables for the SGMAH and SGMPH Servomotors. These cables have a connector and AMP terminal.

Cables for Servomotors Without Brakes

Table 5.6 shows cable models.

Table 5.6 Cables for Servomotors Without Brakes

Applicable Servomotors	Model	Length (L)
SGMAH and SGMPH Servomotors 200 V 30 to 750 W 100 V 30 to 200 W	JZSP-CMM00-03	3 m (9.84 ft)
	JZSP-CMM00-05	5 m (16.4 ft)
	JZSP-CMM00-10	10 m (32.8 ft)
	JZSP-CMM00-15	15 m (49.2 ft)
	JZSP-CMM00-20	20 m (65.6 ft)
SGMPH-15A Servomotors 1.5 kW	JZSP-CMM20-03	3 m (9.84 ft)
	JZSP-CMM20-05	5 m (16.4 ft)
	JZSP-CMM20-10	10 m (32.8 ft)
	JZSP-CMM20-15	15 m (49.2 ft)
	JZSP-CMM20-20	20 m (65.6 ft)

Figure 5.4 shows cable dimensions.

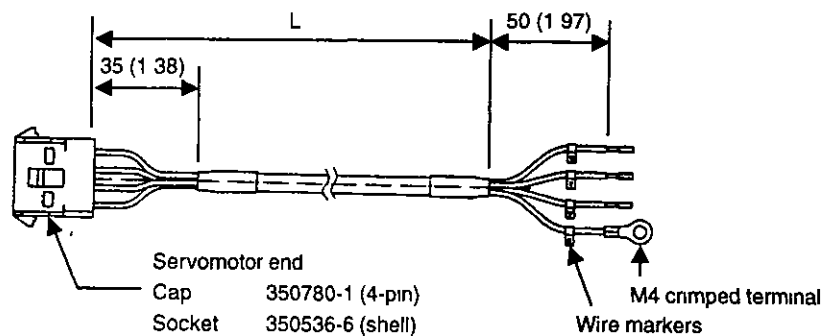

Figure 5.4 Cables for Servomotors Without Brakes

Cables for Servomotors With Brakes

Table 5.7 shows cable models

Table 5.7 Cables for Servomotors With Brakes

Applicable Servomotors	Models	Length (L)
SGMAH and SGMPH Servomotors- 200 V 30 to 750 W 100 V 30 to 200 W	JZSP-CMM10-03	3 m (9.84 ft)
	JZSP-CMM10-05	5 m (16.4 ft)
	JZSP-CMM10-10	10 m (32.8 ft)
	JZSP-CMM10-15	15 m (49.2 ft)
	JZSP-CMM10-20	20 m (65.6 ft)
SGMPH-15A Servomotors 1.5 kW	JZSP-CMM30-03	3 m (9.84 ft)
	JZSP-CMM30-05	5 m (16.4 ft)
	JZSP-CMM30-10	10 m (32.8 ft)
	JZSP-CMM30-15	15 m (49.2 ft)
	JZSP-CMM30-20	20 m (65.6 ft)

Figure 5.5 shows cable dimensions

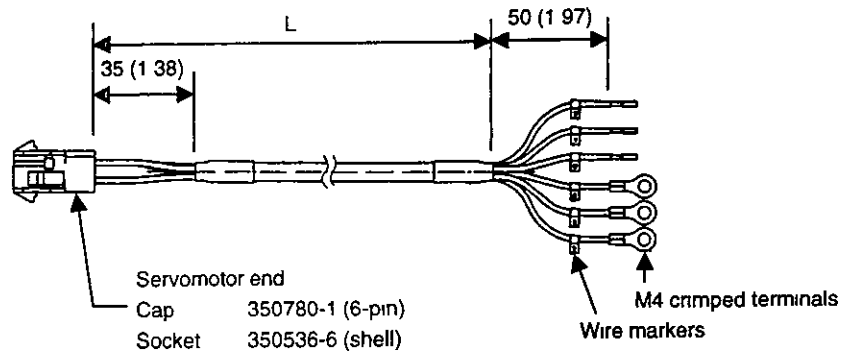

Figure 5.5 Cables for Servomotors With Brakes

Encoder Cables

Encoder cables are used to connect the Servopack to the encoder mounted to the Servomotor

The following section shows encoder cable models and appearance. Specify the cable model when ordering.

Cables With Servopack and Servomotor Connectors

Table 5.8 shows cable models.

Table 5.8 Cables With Servopack and Servomotor Connectors

Applicable Servomotors		Models	Length (L)
SGMAH, SGMPH Servomotor		JZSP-CMP00-03	3 m (9.84 ft)
		JZSP-CMP00-05	5 m (16.4 ft)
		JZSP-CMP00-10	10 m (32.8 ft)
		JZSP-CMP00-15	15 m (49.2 ft)
		JZSP-CMP00-20	20 m (65.6 ft)
SGMGH, SGMSH, SGMDH Servomotor	With straight plug	JZSP-CMP01-03	3 m (9.84 ft)
		JZSP-CMP01-05	5 m (16.4 ft)
		JZSP-CMP01-10	10 m (32.8 ft)
		JZSP-CMP01-15	15 m (49.2 ft)
		JZSP-CMP01-20	20 m (65.6 ft)
	With L-shaped plug	JZSP-CMP02-03	3 m (9.84 ft)
		JZSP-CMP02-05	5 m (16.4 ft)
		JZSP-CMP02-10	10 m (32.8 ft)
		JZSP-CMP02-15	15 m (49.2 ft)
		JZSP-CMP02-20	20 m (65.6 ft)

Cable dimensions are shown in the figure below.

• Cables for the SGMAH, SGMSH and SGMDH Servomotors

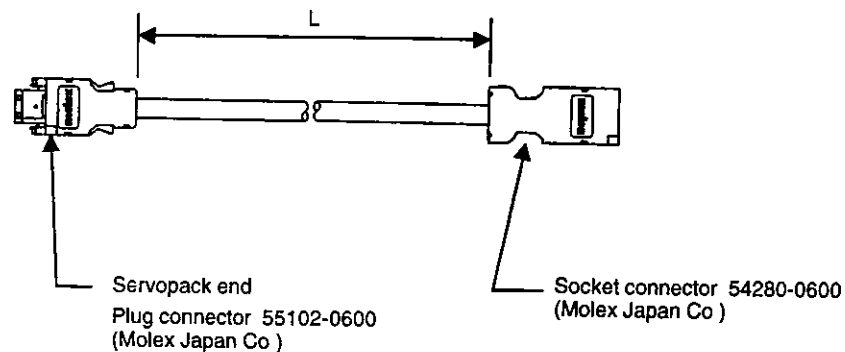

● **SGMGH, SGMSH and SGMDH Servomotor Cables With Straight Plugs**

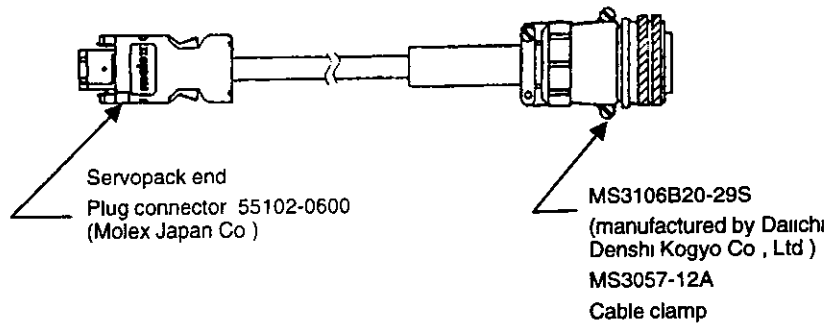

● **SGMGH, SGMSH and SGMDH Servomotor Cables With L-shaped Plugs**

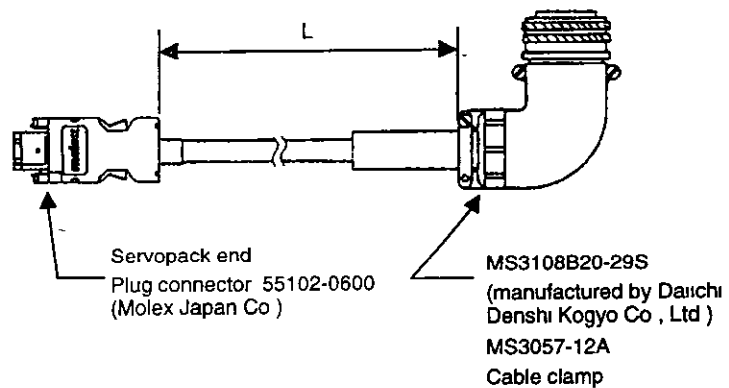

Cables With a Servopack Connector and Encoder Loose Leads

Table 5 9 shows cable models

Table 5 9 Cables With a Servopack Connector and Encoder Loose Leads

Models	Length (L)
JZSP-CMP03-03	3 m (9 84 ft)
JZSP-CMP03-05	5 m (16 4 ft)
JZSP-CMP03-10	10 m (32 8 ft)
JZSP-CMP03-15	15 m (49 2 ft)
JZSP-CMP03-20	20 m (65 6 ft)

Cable dimensions are shown in the figure below

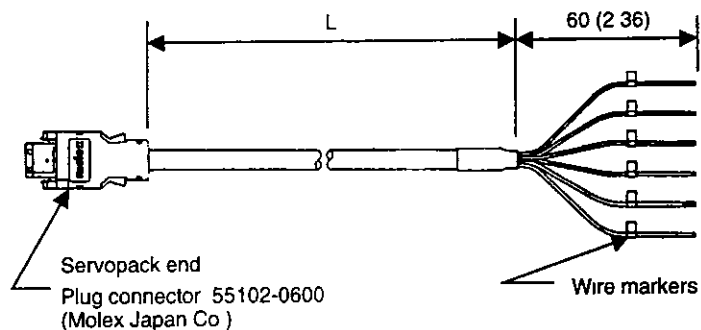

Cables Without Connectors

The following describes models and specifications for encoder cables without connectors. *Table 5.10* shows cable models and lengths.

Table 5.10 Cables Without Connectors

Cable Types	Models	Length (L)
A standard encoder cable can be used up to 20 m (65.6 ft)	JZSP-CMP09-05	5 m (16.4 ft)
	JZSP-CMP09-10	10 m (32.8 ft)
	JZSP-CMP09-15	15 m (49.2 ft)
	JZSP-CMP09-20	20 m (65.6 ft)
A 50-m specification encoder cable can be used up to 50 m (164 ft)	JZSP-CMP19-30	30 m (98.4 ft)
	JZSP-CMP19-40	40 m (131 ft)
	JZSP-CMP19-50	50 m (164 ft)

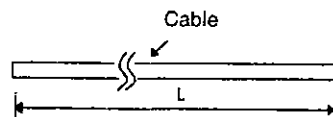
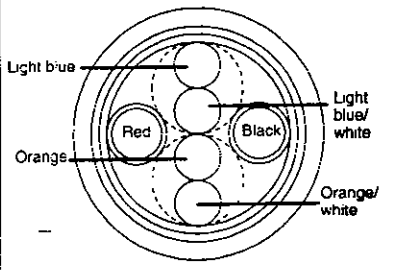
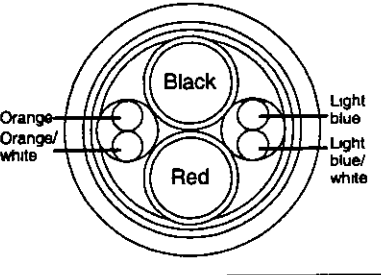

Table 5.11 shows specifications for encoder cables without connectors. These cables are not Servopack or Servomotor accessories and must be purchased separately.



Table 5 11 Applicable Cable

Cable Specifications	Length 20 m (65 6 ft) max.	Length: 50 m (164 ft) max.
Basic Specifications	T/20276-SB AWG22x2C+AWG24x2P	T/20276-SB AWG16x2C+AWG26x2P
Finished Dimensions	φ6 5 mm (ø0 26 in)	φ6 8 mm (ø0 27 in)
Internal Configuration and Lead Colors		
Yaskawa Standard Specifications	Standard lengths 5 m (16 4 ft), 10 m (32 8 ft), 15 m (49 2 ft), 20 m (65 6 ft)	Standard lengths 30 m (98 4 ft), 40 m (131 ft), 50 m (164 ft)

Connector Kits

A connector kit is comprised of an encoder connector for the Servomotor and Servopack end of the cable *Table 5 12* shows cable kit models and appearance

Table 5 12 Connector Kit Types

Type	Connector Kit Model	List of Connector Kit Parts
Plug for a Servopack CN2 encoder connector	JZSP-CMP9-1	
Socket for a Servomotor SGMAH and SGMPH Servomotor connector	JZSP-CMP9-2	

■ CN1 Cables for I/O Signals

These cables do not have a host controller connector The loose leads are labeled with terminal numbers

Table 5 13 shows cable models and lengths

Table 5.13 Cable Models and Length

Models	Length (L)
JZSP-CKI01-1	1 m (3 28 ft)
JZSP-CKI01-2	2 m (6 56 ft)
JZSP-CKI01-3	3 m (9 84 ft)

5.2.3 Connectors

The model of connector varies with the type of Servomotor

The connectors here are grouped into SGMAH and SGMPH Servomotor connectors at SGMGH and SGMSH Servomotor connectors

■ SGMAH and SGMPH Servomotor Connectors

Connectors are available in three types With an encoder connector at the Servomotor or Servopack ends of the cable and with a Servomotor connector at the Servomotor end of the cable

- Encoder Connector at the Servomotor End of the Cable

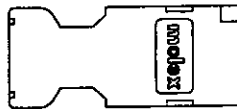

- Encoder Connector at the Servopack End of the Cable

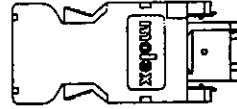

- Main Circuit (Power Line) Connector at the Servomotor End of the Cable

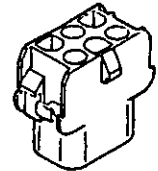

Connectors vary depending on whether the Servomotor has a brake or not

Purchase one of these connectors in the following cases

- When the Servomotor cable is a cable only for Servomotors with and without brakes
- When the encoder cable is a cable only or has a Servopack connector (loose leads on the Servomotor end)

Encoder Cable Connectors (Servomotor End)

The same connector is used for both incremental and absolute encoders

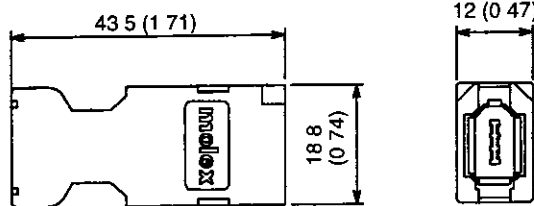

Model 54280-0600 manufactured by Molex Japan Co

Servomotor Main Circuit Cable Connectors

The shape of the connectors will vary depending on whether the Servomotor has a brake or not

Socket types will vary for SGMFH-15A Servomotors

• For Servomotors Without Brakes

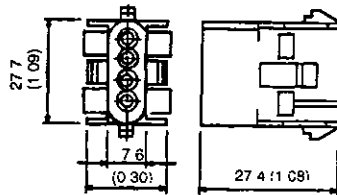

Cap 350780-1

Socket 350570-3 or 350689-3
350536-6 or 350550-6 (SGMFH-15A)

Manufactured by Japan AMP Co., Ltd

• For Servomotors With Brakes

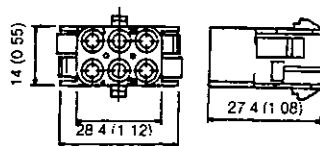

Cap 350781-1

Socket 350570-3 or 350689-3
350536-6 or 350550-6 (SGMFH-15A)

Manufactured by Japan AMP Co., Ltd

■ SGMFH, SGMFH and SGMFH Servomotor Connectors

Connectors are available in three types With an encoder connector at the Servomotor or Servopack ends of the cable and with a Servomotor connector at the Servomotor end of the cable

- Encoder Connector at the Servomotor End of the Cable

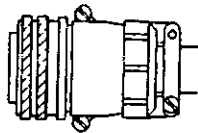

- Encoder Connector at the Servopack End of the Cable

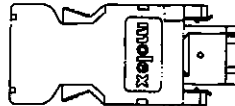

- Main Circuit (Power Line) Connector at the Servomotor End of the Cable

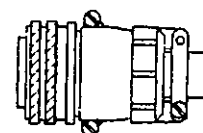

Note The customer must provide clamp terminals for connecting the Servomotor on the Servopack end (2 kW or higher Servomotor)

Connectors vary according to the following conditions

- Plug shape
- Servomotor with or without brake
- Servomotor model and capacity
- Applicable environment

Order the connectors in the following cases

- For all Servomotor cables regardless of whether the Servomotor has a brake or not
- For an encoder cable with a connector only on the Servopack end or an encoder cable only regardless of whether the encoder is incremental or absolute
- For all IP67-compatible encoder cables (Servomotor and Servopack ends)

Encoder Cable Connectors

Encoder cable connectors are grouped by environment specifications and plug shape

Table 5 14 shows encoder cable types

Table 5 14 -Encoder Cable Types

Applicable Environment		Part	Straight	L-shaped (Angled)	Manufacturer
Standard Environment	-	Plug	MS3106B20-29S	MS3108B20-29S	Daichi Denshi Kogyo Co., Ltd
		Cable clamp	MS3057-12A-*		
IP67-compatible Environment	With a flexible conduit	Plug	MS3106A20-29S (D190)	-	
	Without a flexible conduit	Plug	MS3106A20-29S (D190)		
		Back shell	CE02-20BS-S	CE-20BA-S	
		Cable clamp	CE3057-12A-* JL04-□□CK-(*)		

Note Select cable clamps marked with an asterisk (*) based on wire diameter

Connectors manufactured by Daichi Denshi Kogyo Co., Ltd are shown in the figure below

● Standard Environment Connector Configurations

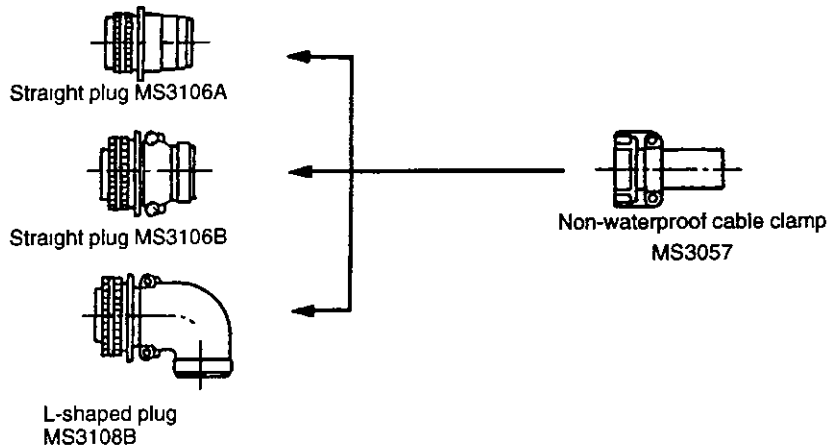

● IP67-environment Connector Configurations

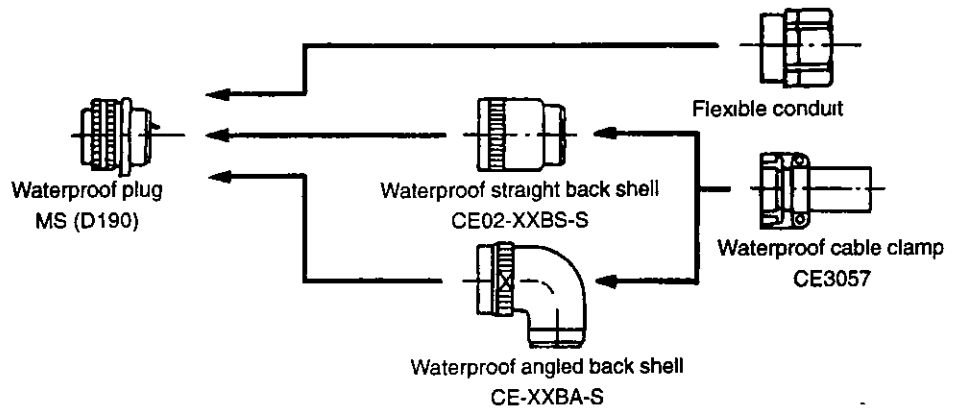

Servomotor Main Circuit Cable Connectors

Servomotor main circuit cable connectors are grouped by the applicable environment, whether or not there is a brake, and by Servomotor model and capacity

The customer must provide crimp terminals for the Servopack end

Standard Environment Connectors

- **Connectors for Standard Servomotors Without Brakes**

Table 6 15 shows connector configurations

Table 5.15 Connector Configurations for Servomotors Without Brakes

Servomotor Model	Servomotor Connector Models			
	Receptacle	L-shaped Plug	Straight Plug	Cable Clamp
SGMSH- 10A□A 15A□A 20A□A 30A□A 40A□A 50A□A	MS3102A18-10P	MS3108B18-10S	MS3106B18-10S	MS3057-10A
SGMGH- 05A□A 09A□A 13A□A 20A□A 30A□A 44A□A 55A□A 75A□A 1AA□A 1EA□A	MS3102A22-22P MS3102A32-17P	MS3108B22-22S MS3108B32-17S	MS3106B22-22S MS3106B32-17S	MS3057-12A MS3057-20A
SGMGH- 03A□B 06A□B 09A□B 12A□B 20A□B 30A□B 40A□B 55A□B	MS3102A18-10P MS3102A22-22P MS3102A32-17P	MS3108B18-10S MS3108B22-22S MS3108B32-17S	MS3106B18-10S MS3106B22-22S MS3106B32-17S	MS3057-10A MS3057-12A MS3057-20A
SGMDH- 22A 32A 40A	MS3102A24-10P	MS3108B24-10S	MS3106B24-10S	MS3057-16A

Note 1 Receptacles are Servomotor connectors

2. Customers must provide plugs (L shaped or straight) as well as cable clamps

MS3106B Straight Plug Shell

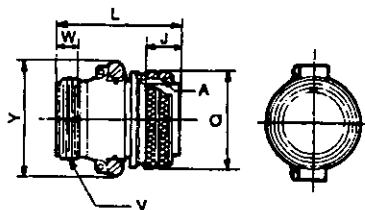

Specifications and Dimensional Drawings for Peripheral Devices

5 2 3 Connectors

Units mm (in)

Shell Size	Joint Screw A	Length of Joint Portion J±0.12 (0.0047)	Overall Length L max	Outside Diameter of Joint Nut $\phi Q \begin{smallmatrix} 0 \\ -0.38(0.015) \end{smallmatrix}$	Cable Clamp Set Screw V	Effective Screw Length W min.	Maximum Width Y max
18	1/8-18UNEF	18.26 (0.718)	52.37 (2.062)	34.13 (1.344)	1-20UNEF	9.53 (0.375)	42 (1.65)
20	1/4-18UNEF	18.26 (0.718)	55.57 (2.188)	37.28 (1.468)	1 3/16-18UNEF	9.53 (0.375)	47 (1.85)
22	3/8-18UNEF	18.26 (0.718)	55.57 (2.188)	40.48 (1.594)	1 3/16-18UNEF	9.53 (0.375)	50 (1.97)
24	1/2-18UNEF	18.26 (0.718)	58.72 (2.312)	43.63 (1.718)	1 7/16-18UNEF	9.53 (0.375)	53 (2.09)
32	2-18UNS	18.26 (0.718)	61.92 (2.438)	56.33 (2.222)	1 3/4-18UNS	11.13 (0.4382)	66 (2.60)

MS3108B L-shaped Plug Shell

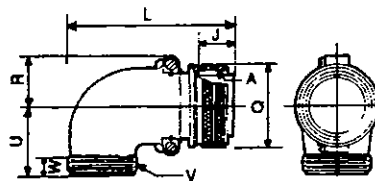

Units mm (in)

Shell Size	Joint Screw A	Length of Joint Portion J±0.12 (0.0047)	Overall Length L max	Outside Diameter of Joint Nut $\phi Q \begin{smallmatrix} 0 \\ -0.38(0.015) \end{smallmatrix}$	R±0.5 (0.020)	U±0.5 (0.020)	Cable Clamp Set Screw V	Effective Screw Length W max.
18	1/8-18UNEF	18.26 (0.7189)	68.27 (2.688)	34.13 (1.344)	20.5 (0.807)	30.2 (1.19)	1-20UNEF	9.53 (0.375)
20	1/4-18UNEF	18.26 (0.7189)	76.98 (3.031)	37.28 (1.468)	22.5 (0.886)	33.3 (1.31)	1 3/16-18UNEF	9.53 (0.375)
22	3/8-18UNEF	18.26 (0.7189)	76.98 (3.031)	40.48 (1.594)	24.1 (0.949)	33.3 (1.31)	1 3/16-18UNEF	9.53 (0.375)
24	1/2-18UNEF	18.26 (0.7189)	86.51 (3.406)	43.63 (1.718)	25.6 (1.01)	36.5 (1.44)	1 7/16-18UNEF	9.53 (0.375)
32	2-18UNS	18.26 (0.7189)	95.25 (3.750)	56.33 (2.222)	32.8 (1.29)	44.4 (1.75)	1 3/4-18UNS	11.13 (0.438)

MS3106A Straight Plug Solid Shell

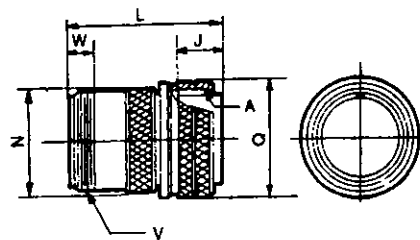

Units mm (in)

Shell Size	Joint Screw A	Length of Joint Portion $J \pm 0.12$ (0.0047)	Overall Length L max	Outside Diameter of Joint Nut $\phi Q \begin{smallmatrix} 0 \\ -0.38 \end{smallmatrix} (0.015)$	Outer Diameter $\phi N \pm 0.5$ (0.020)	Cable Clamp Set Screw V	Effective Screw Length W max.
10SL	5/8-24UNEF	13.49 (0.5311)	34.9 (1.37)	22.22 (0.8748)	19.12 (0.7528)	5/8-24UNEF	9.53 (0.375)



MS3057-XXA Cable Clamp with Rubber Bushing

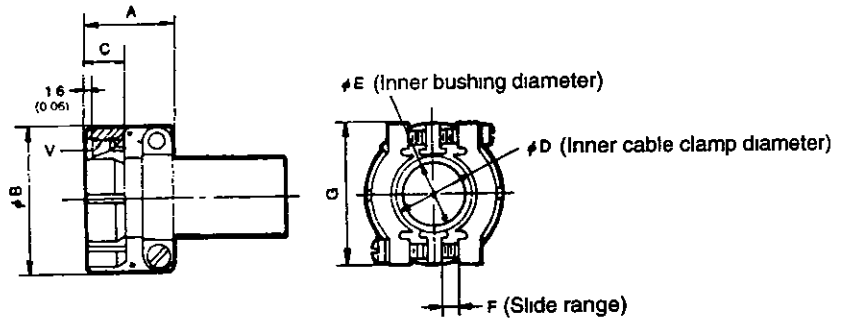

Units mm (in)

Part Number	Applicable Connector Shell Size	Overall Length A±0.7 (0.028)	Outer Diameter øB±0.7 (0.028)	Effective Screw Length C	φD	φE	F	G±0.7 (0.028)	Set Screw V	Attached Bushing
MS3057-4A	10SL, 12S	20.6 (0.811)	20.6 (0.811)	10.3 (0.406)	7.9 (0.311)	5.6 (0.220)	1.6 (0.063)	22.2 (0.874)	5/8-24UNEF	AN3420-4
MS3057-10A	18	23.8 (0.937)	30.1 (1.19)	10.3 (0.406)	15.9 (0.626)	14.3 (0.563)	3.2 (0.13)	31.7 (1.25)	1-20UNEF	AN3420-10
MS3057-12A	20, 22	23.8 (0.937)	35.0 (1.38)	10.3 (0.406)	19.0 (0.748)	15.9 (0.626)	4.0 (0.16)	37.3 (1.47)	1 3/16-18UNEF	AN3420-12
MS3057-16A	24, 28	26.2 (1.03)	42.1 (1.66)	10.3 (0.406)	23.8 (0.937)	15.9 (0.626) 19.1 (0.752)	4.8 (0.19)	42.9 (1.69)	1 7/16-18UNEF	AN3420-12 AN3420-16
MS3057-20A	32	27.8 (1.09)	51.6 (2.03)	11.9 (0.469)	31.7 (1.25)	19.1 (0.752) 23.8 (0.937)	6.3 (0.25)	51.6 (2.03)	1 3/4-18UNS	AN3420-16 AN3420-20

• Connectors for Servomotors With Brakes

Table 5.16 shows the connector configurations

Table 5.16 Connectors for Servomotors With Brakes

Servomotor Model	Servomotor Connector Models			
	Receptacle	L-shaped Plug	Straight Plug	Cable Clamp
SGMSH- 10A□A 15A□A 20A□A	MS3102A20-15P	MS3108B20-15S	MS3106B20-15S	MS3057-12A
30A□A 40A□A 50A□A	MS3102A24-10P	MS3108B24-10S	MS3106B24-10S	MS3057-16A

Servomotor Model	Servomotor Connector Models			
	Receptacle	L-shaped Plug	Straight Plug	Cable Clamp
SGMGH- 05A□A 09A□A 13A□A 20A□A 30A□A 44A□A 55A□A 75A□A	MS3102A20-15P	MS3108B20-15S	MS3106B20-15S	MS3057-12A
	MS3102A24-10P	MS3108B24-10S	MS3106B24-10S	MS3057-16A
	MS3102A32-17P	MS3108B32-17S	MS3106B32-17S	MS3057-20A
	MS3102A10SL-3P*	MS3108A10SL-3S*	MS3106A10SL-3S*	MS3057-4A*
SGMGH- 03A□B 06A□B 09A□B 12A□B 20A□B 30A□B 40A□B 55A□B	MS3102A20-15P	MS3108B20-15S	MS3106B20-15S	MS3057-12A
	MS3102A24-10P	MS3108B24-10S	MS3106B24-10S	MS3057-16A
	MS3102A32-17P	MS3108B32-17S	MS3106B32-17S	MS3057-20A
	MS3102A10SL-3P*	MS3108A10SL-3S*	MS3106A10SL-3S*	MS3057-4A*
SGMDH- 22A 32A 40A	MS3102A24-10P	MS3108B24-10S	MS3106B24-10S	MS3057-16A

* Connectors for Brake Power Supplies

Note 1 Receptacles are Servomotor connectors

2. Customers must provide plugs (L shaped or straight) as well as cable clamps

Connectors for IP67 Environments

• Connectors for Servomotors Without Brakes

Table 5 17 shows the connector configurations

Table 5.17 Connectors for Servomotors Without Brakes

Servomotor Model	Receptacle (Servomotor Connector)	Plug ⁷ (Select plug when using the flexible conduit.)	End Bell: Japan Aviation Electronics Industry, Ltd. Back Shell. Daichi Denshi Kogyo Co , Ltd ^{3*6*7}		Cable Clamp ^{6*7}	Manufacturer
			L-shaped (Angled)	Straight		
SGMSH- 10A□A 15A□A 20A□A 30A□A 40A□A 50A□A	CE05-2A18-10PD (MS3102A18-10P) ⁵	MS3106A18-10S (D190)	CE-18BA-S	CE02-18BS-S	CE3057-10A-Δ ⁴	Daichi Denshi Kogyo Co , Ltd
	JL04HV-2E22-22PE-B (MS3102A22-22P) ⁵	JL04V-6A22-22SE	JL04-22EBL	JL04-22EB	JL04-2022CK (14)	Japan Aviation Electronics Industry, Ltd



Specifications and Dimensional Drawings for Peripheral Devices

5 2 3 Connectors

Servomotor Model	Receptacle (Servomotor Connector)	Plug ^{*7} (Select plug when using the flexible conduit.)	End Bell: Japan Aviation Electronics Industry, Ltd. Back Shell: Daichi Denshi Kogyo Co., Ltd. ^{*3*6*7}		Cable Clamp ^{*6*7}	Manufacturer
			L-shaped (Angled)	Straight		
SGMGH- 05A□A 09A□A 13A□A	CE05-2A18-10PD (MS3102A18-10P) ^{*5}	MS3106A18-10S (D190)	CE-18BA-S	CE02-18BS-S	CE3057-10A-Δ ^{*4}	Daichi Denshi Kogyo Co., Ltd
	JL04HV-2E22-22PE-B (MS3102A22-22P) ^{*5}	JL04V-6A22-22SE	JL04-22EBL	JL04-22EB	JL04-2022CK (14)	Japan Aviation Electronics Industry, Ltd
	JL04V-2E32-17PE-B (MS3102A32-17P) ^{*5}	JL04V-6A32-17SE	*2	*2	*2	Japan Aviation Electronics Industry, Ltd
SGMGH- 03A□B 06A□B 09A□B	CE05-2A18-10PD (MS3102A18-10P) ^{*5}	MS3106A18-10S (D190)	CE-18BA-S	CE02-18BS-S	CE3057-10A-Δ ^{*4}	Daichi Denshi Kogyo Co., Ltd
	JL04HV-2E22-22PE-B (MS3102A22-22P) ^{*5}	JL04V-6A22-22SE	JL04-22EBL	JL04-22EB	JL04-2022CK (14)	Japan Aviation Electronics Industry, Ltd
	JL04V-2E32-17PE-B (MS3102A32-10P) ^{*5}	JL04V-6A32-17SE	*2	*2	*2	Japan Aviation Electronics Industry, Ltd
SGMDH- 22A□A 32A□A 40A□A	JL04V-2E24-10PE-B (MS3102A24-10P) ^{*5}	JL04-6A24-10SE	JL04-24EBL	JL04-24EB	JL04-2428CK (17)	Japan Aviation Electronics Industry, Ltd
For detector ^{*1}	97-F3102E20-29P (MS3102A20-29P) ^{*5}	MS3106A20-29S (D190)	CE-20BA-S	CE02-20BS-S	CE3057-12A-Δ ^{*4}	Daichi Denshi Kogyo Co., Ltd

* 1. The same detector connector is used for all the Servomotor models

* 2. The SGMGH-55A□A, -75A□A, -40A□B, and -55A□B Motor Units are not equipped with End Bell For these models, use the flexible conduits shown in the following table. Select connectors and conduits marked with □□ based on lead wire diameter. For details, see Table 5 19

Connector		Conduit	Manufacturer
L-shaped (Angled)	Straight		
RCC-3□□RL-MS32F	RCC-1□□RL-MS32F	VF-□□ (SR-□□)	Nippon Flex Co., Ltd

* 3. End Bell is a product of Japan Aviation Electronics Industry, Ltd. Back Shell is a product of Daichi Denshi Kogyo Co., Ltd

- * 4. Select Cable Clamps marked with Δ based on lead wire diameter For details, see *Table 5 20*
- * 5 The Receptacles in parentheses are for general use
- * 6. End Bell, Back Shell and Cable Clamps are not used when using flexible conduit
- * 7. Customers must provide Plug, End Bell, Back Shell and Cable Clamps

• **Connectors for Servomotors With Brakes**

Table 5 18 shows the connector configurations

Table 5.18 Connectors for Servomotors With Brakes

Servomotor Model	Receptacle (Servomotor Connector)	Plug ^{*8}	End Bell: Japan Aviation Electronics Industry, Ltd. Back Shell: Daichi Denshi Kogyo Co., Ltd.*3*7*8		Cable Clamp ^{*7*8}	Manufacturer
			L-shaped (Angled)	Straight		
SGMSH- 10A□A 15A□A 20A□A	JL04V-2E20 -15PE-B (MS3102A20-15 P)*6	JL04V-6A20 -15SE	JL04-20EBL	JL04-20EB	JL04-2022CK (14)	Japan Aviation Electronics Industry, Ltd
	30A□A 40A□A 50A□A	JL04V-2E24 -10PE-B (MS3102A24-10 P)*6	JL04V-6A24 -10SE	JL04-24EBL JL04-24EB		
SGMGH- 05A□A 09A□A 13A□A	JL04V-2E20 -15PE-B (MS3102A20-15 P)*6	JL04V-6A20 -15SE	JL04-20EBL	JL04-20EB	JL04-2022CK (14)	Japan Aviation Electronics Industry, Ltd
	20A□A 30A□A 44A□A	JL04V-2E24 -10PE-B (MS3102A24-10 P)*6	JL04V-6A24 -10SE	JL04-24EBL JL04-24EB		
55A□A 75A□A	JL04V-2E32-17P E-B (MS3102A32-17 P) *CE05-2A10SL-3PC *(MS3102A10SL-3P)*5 *6	JL04V-6A32-17SE *MS3106A10SL-3S (D190)*5	*CE-10SLBA-S*2 *5	*CE-10SLBS-S*2, *5	*CE3057-4A-1*2, *5	Japan Aviation Electronics Industry, Ltd Daichi Denshi Kogyo Co., Ltd
SGMGH- 03A□B 06A□B 09A□B	JL04V-2E20 -15PE-B (MS3102A20-15 P)*6	JL04V-6A20 -15SE	JL04-20EBL	JL04-20EB	JL04-2022CK (14)	Japan Aviation Electronics Industry, Ltd
	12A□B 20A□B 30A□B	JL04V-2E24 -10PE-B (MS3102A24-10 P)*6	JL04V-6A24 -10SE	JL04-24EBL JL04-24EB		

Specifications and Dimensional Drawings for Peripheral Devices

5 2 3 Connectors

Servomotor Model	Receptacle (Servomotor Connector)	Plug*8	End Bell: Japan Aviation Electronics Industry, Ltd. Back Shell: Daichi Denshi Kogyo Co., Ltd.*3*7*8		Cable Clamp*7*8	Manufacturer
			L-shaped (Angled)	Straight		
40A□B 55A□B	JL04V-2E32-17P E-B (MS3102A32-17P) *CE05-2A10SL-3PC *(MS3102A10S L-3P)*6	JL04V-6A32-17SE *MS3106A10S L-3S (D190)	*CE-10SLB A-S*2	*CE-05SLBS-S*2	*CE3057-4A-1*2	Japan Aviation Electronics Industry, Ltd Daichi Denshi Kogyo Co., Ltd
SGMDH- 22A□A 32A□A 40A□A	JL04V-2E24-10P E-B (MS3102A24-10P)*6	JL04V-6A24-10SE	JL04-24EBL	JL04-24EB	JL04-2428CK (17)	Japan Aviation Electronics Industry, Ltd
For detector*1	97F3102E20-29P (MS3102A20-29P)*6	MS3106A20-29S (D190)	CE-20BA-S	CE02-20BS-S	CE3057-12A-Δ*4	Daichi Denshi Kogyo Co., Ltd

* 1. The same detector connector is used for all the Servomotor models

* 2. The SGMGH-55A□A, -75A□A, -40A□B, and -55A□B Motor Units are not equipped with End Bell For these models, use the flexible conduits shown in the following table Select connectors and conduits marked with □□ based on lead wire diameter For details, see Table 5 19

Connector		Conduit	Manufacturer
L-shaped (Angled)	Straight		
RCC-3□□RL-MS32F	RCC-1□□RL-MS32F	VF-□□ (SR-□□)	Nippon Flex Co., Ltd

* 3. End Bell is a product of Japan Aviation Electronics Industry, Ltd Back Shell is a product of Daichi Denshi Kogyo Co., Ltd

* 4. Select Cable Clamps marked with Δ based on lead wire diameter For details, see Table 5 20

* 5. The model in the upper row is a main motor circuit, while the model in the lower row is a brake power supply connector

* 6. The Receptacles in parentheses are for general use

* 7. End Bell, Back Shell and Cable Clamps are not used when using flexible conduit

* 8. Customers must provide Plug, End Bell, Back Shell and Cable Clamps

Table 5.19 Flexible Conduits and Connectors

Connector		Conduit	Applicable Cable Range
L-shaped (Angled)	Straight		
RCC-306RL-MS32F	RCC-106RL-MS32F	VF-06 (SR-06)	φ19 max
RCC-308RL-MS32F	RCC-108RL-MS32F	VF-08 (SR-08)	φ24 max
RCC-310RL-MS32F	RCC-110RL-MS32F	VF-10 (SR-10)	φ33 max

Connector		Conduit	Applicable Cable Range
L-shaped (Angled)	Straight		
RCC-312RL-MS32F	RCC-112RL-MS32F	VF-12 (SR-12)	φ38 max
RCC-316RL-MS32F	RCC-116RL-MS32F	VF-16 (SR-16)	φ49 max

Table 5.20 Cable Clamps Classified Based on Wire Diameter

Cable Clamp	Applicable Cable Range	Manufacturer
CE3057-10A-1	φ10.5 to φ14.1	Daichi Denshi Kogyo Co., Ltd
CE3057-10A-2	φ8.5 to φ11.0	
CE3057-10A-3	φ5.5 to φ9.7	
CE3057-12A-1	φ12.5 to φ16.0	
CE3057-12A-2	φ9.5 to φ13.0	
CE3057-12A-3	φ6.8 to φ10.0	
JL04-2022CK (14)	φ12.9 to φ15.9	Japan Aviation Electronics Industry, Ltd
JL04-2428CK (17)	φ15 to φ18	

MS (D190) Series MS3106A20-29S (D190) Plug for Conduits

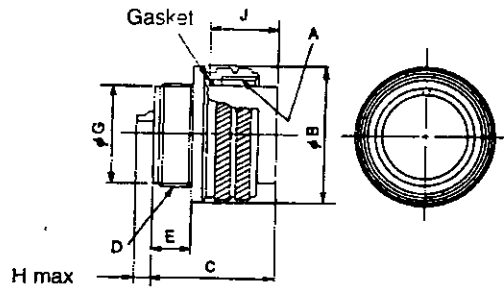

Units: mm (in)

Shell Size	A	φB ⁺⁰ / _{-0.38 (0.015)}	C ±0.5 (0.020)	D	E ±0.3 (0.012)	φG ^{+0.05 (0.0020)} / _{-0.25 (0.0098)}	J ±0.12 (0.0047)
10SL	5/8-24UNEF-2B	22.22 (0.875)	23.3 (0.917)	9/16-24UNEF-2A	7.5 (0.30)	12.5 (0.492)	13.49 (0.531)
20	1 1/4-18UNEF-2B	37.28 (1.468)	34.11 (1.343)	1 1/18-18UNEF-2A	12.16 (0.479)	26.8 (1.055)	18.26 (0.718)

CE02-XXBS-S Straight Back Shell for the MS (D190)

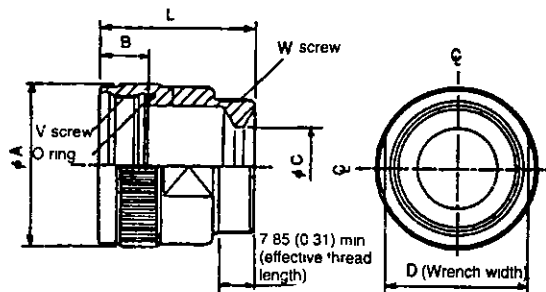

Units mm (in)

Shell Size	Name	L	φA	B	φC	D	V	W
18	CE02-18BS-S	31 (1 22)	30 5 (1 20)	10 5 (0 413)	16 3 (0 642)	26 7 (1 05)	1-20UNEF-2B	1-20UNEF-2A
20	CE02-20BS-S	35 (1 38)	35 (1 38)	10 9 (0 429)	17 8 (0 700)	31 6 (1 24)	1 1/8-18UNEF-2B	1 3/16-18UNEF-2A

CE-XXBA-S (XXX) Angled Back Shell for the MS(D190)

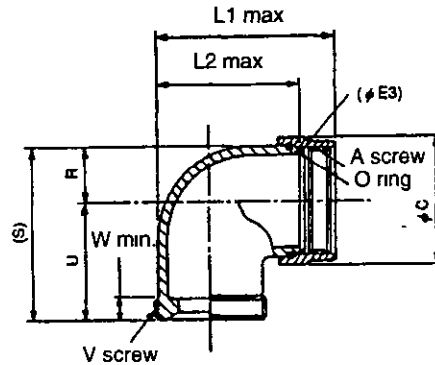

Units mm (in)

Part Number	Shell Size	Joint Screw A	Overall Length L1	Overall Length of Angle Body L2	Outside Diameter of Coupling C	R	U	(S)	Cable Clamp Set Screw V	Effective Screw Length W
CE-10SLBA-S	10SL	9/16-24UNEF-2B	30 6 (1 20)	22 5 (0 885)	21 7 (0 854)	7 9 (0 31)	21 (0 83)	28 9 (1 14)	5/8-24UNEF-2A	7 5 (0 30)
CE-18BA-S	18	1-20-UNEF-2B	44 6 (1 76)	34 (1 34)	32 4 (1 28)	13 2 (0 520)	30 2 (1 19)	43 4 (1 71)	1-20UNEF-2A	7 5 (0 30)
CE-20BA-S	20	1 1/8-18UNEF-2B	50 5 (1 99)	39 6 (1 56)	36 (1 42)	15 (0 591)	33 3 (1 31)	48 3 (1 90)	1 3/16-18UNEF-2A	7 5 (0 30)

CE3057-XXA Waterproof Cable Clamp with Rubber Bushing for the MS(D190)

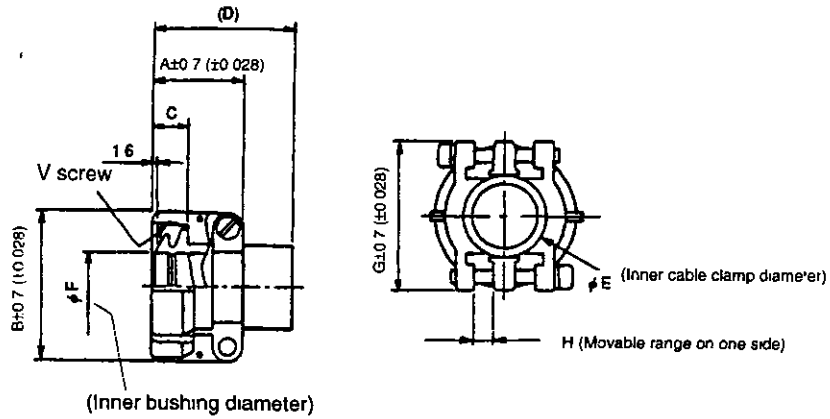

Units mm (in)

Part Number	Shell Size	Overall Length A	Outer Diameter B	Effective Screw Length C	(D)	E	F	G	H	Set Screw V	Attached Bushing	Applicable Cable Range (For reference)	
CE3057-4A-1	10SL	20.6 (0.811)	20.6 (0.811)	10.3 (0.406)	(41.3) (1.63)	7.9 (0.311)	5.6 (0.220)	22.2 (0.874)	1.6 (0.063)	5/8-24UNEF-2B	CE3420-4-1	φ3.6 (φ0.14) to φ5.6 (φ0.22)	
CE3057-10A-1	18	23.8 (0.937)	30.1 (1.19)	10.3 (0.406)	(41.3) (1.63)	15.9 (0.626)	14.1 (0.555)	31.7 (1.25)	3.2 (0.13)	1-20UNEF-2B	CE3420-10-1	φ10.5 (φ0.41) to φ14.1 (φ0.56)	
CE3057-10A-2												CE3420-10-2	φ8.5 (φ0.33) to φ11 (φ0.43)
CE3057-10A-3												CE3420-10-3	φ5.5 (φ0.22) to φ9.7 (φ0.38)
CE3057-12A-1	20 22	23.8 (0.937)	35 (1.38)	10.3 (0.406)	(41.3) (1.63)	19 (0.748)	16 (0.63)	37.3 (1.47)	4 (0.16)	1/316-18UNEF-2B	CE3420-12-1	φ12.5 (φ0.49) to φ16 (φ0.63)	
CE3057-12A-2												CE3420-12-2	φ9.5 (φ0.37) to φ13 (φ0.51)
CE3057-12A-3												CE3420-12-3	φ6.8 (φ0.27) to φ10 (φ0.39)
CE3057-16A-1	24 28	26.2 (1.03)	42.1 (1.66)	10.3 (0.406)	(41.3) (1.63)	23.8 (0.937)	19.1 (0.752)	42.9 (1.69)	4.8 (0.19)	1/716-18UNEF-2B	CE3420-16-1	φ15 (φ0.59) to φ19.1 (φ0.75)	
CE3057-16A-2												CE3420-16-2	φ13 (φ0.51) to φ15.5 (φ0.61)



Plug JL04-6A

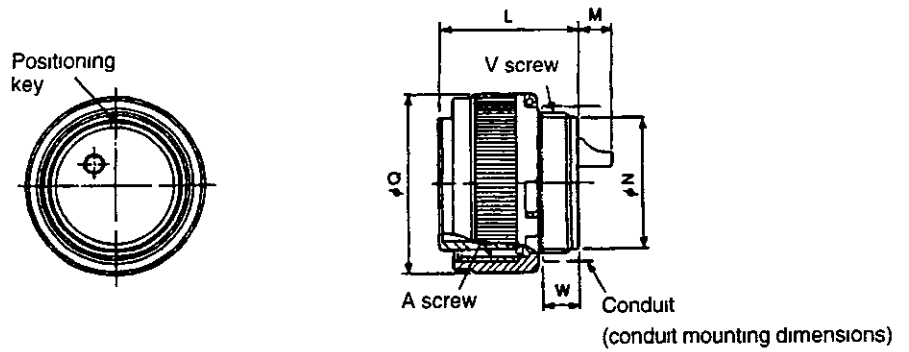

Units mm ()

Shell size	No of Cores	Part Name	Joint Screw A Screw	$L \pm 0.4$ (0.0157)	$M \pm 0.8$ (0.0315)	$N \pm 0.2$ (0.0079)	$Q \pm 0.8$ (0.0315)	V Screw	W max
22	4	JL04-6A22-22S	1/8-18UNEF-2B	31.5 (1.24)	7.6 (0.30)	29.6 (1.17)	40.5 (1.59)	1/4-18UNEF-2A	8 (0.31)
24	7	JL04-6A24-10S	1/2-18UNS-2B	35 (1.38)	5.9 (0.23)	32.8 (1.29)	43.7 (1.72)	1/8-18UNEF-2A	10 (0.39)

Plug JL04V-6A

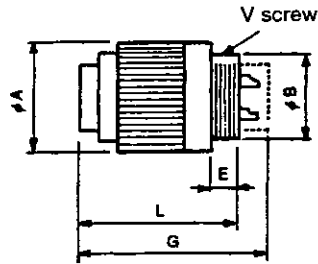

Units mm ()

Shell Size	V Screw	ϕA	ϕB	L	E	G
20	1/8-18UNEF-2A	37.3 ± 0.8 (1.47 ± 0.0315)	27 ± 0.2 (1.06 ± 0.0079)	31.5 ± 0.4 (1.24 ± 0.0157)	8 (0.31) max	-
32	1/8-16UN-2A	56.3 ± 0.8 (2.22 ± 0.0315)	45.4 ± 0.2 (1.79 ± 0.0079)	35.8 ± 0.4 (1.41 ± 0.0157)	10 (0.39) max	-

Straight End Bell JL04-□□EB

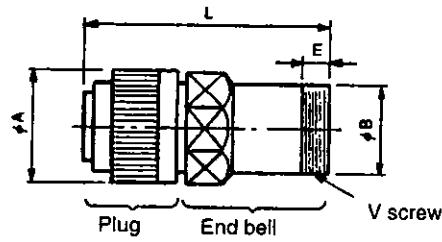

Units mm (in)

Shell Size	V Screw	φA	φB	L	E
20	1 ³ / ₁₆ -18UNEF-2A	37.3±0.8 (1.47± 0.0315)	30.05±0.2 (1.18±0.0079)	67.9±0.8 (2.67± 0.0315)	8 (0.31) min
22	1 ³ / ₁₆ -18UNEF-2A	40.5±0.8 (1.59± 0.0315)	30.05±0.2 (1.18±0.0079)	67.63±0.8 (2.66± 0.0315)	8 (0.31) min
24	1 ⁷ / ₁₆ -18UNEF-2A	43.7±0.8 (1.72± 0.0315)	36.4±0.2 (1.43±0.0079)	71±0.8 (2.80± 0.0315)	8 (0.31) min

L-shaped End Bell JL04-□□EBL

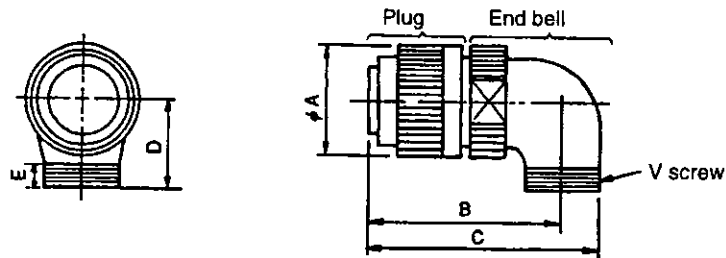

Units mm (in)

Shell Size	V Screw	φA	B	C	D	E
20	1 ³ / ₁₆ -18UNEF-2A	37.3±0.8 (1.47± 0.0315)	60.5±0.8 (2.38± 0.0315)	74.2±0.8 (2.92± 0.0315)	32±0.8 (1.26± 0.0315)	10±0.5 (0.39± 0.0179)
22	1 ³ / ₁₆ -18UNEF-2A	40.5±0.8 (1.59± 0.0315)	60.23±0.8 (2.37± 0.0315)	73.93±0.8 (2.91± 0.0315)	32±0.8 (1.26± 0.0315)	10±0.5 (0.39± 0.0179)
24	1 ⁷ / ₁₆ -18UNEF-2A	43.7±0.8 (1.72± 0.0315)	65±0.8 (2.56± 0.0315)	82±0.8 (3.23± 0.0315)	38±0.8 (1.50± 0.0315)	10±0.5 (0.39± 0.0179)

Cable Clamp JL04-□□CK (**)

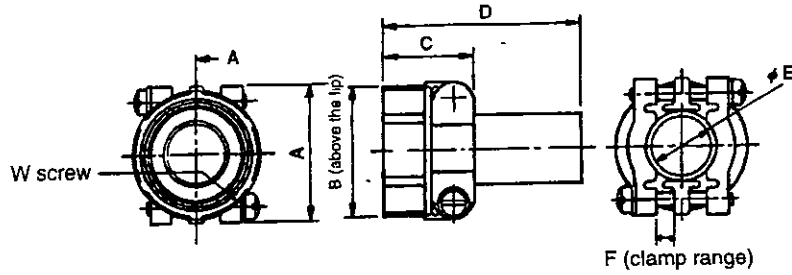

Units mm (in)

Part Name/size	A ± 0.8 (± 0.0315)	B ± 0.8 (± 0.0315)	C ± 0.8 (± 0.0315)	D ± 0.8 (± 0.0315)	$\phi E \pm 0.8$ (± 0.0315)	F	W Screw	Applicable Cable Diameter
JL04-2022CKE (09)	37.3 (1.47)	34.9 (1.37)	24.3 (0.96)	53.8 (2.12)	9.5 (0.37)	4 (0.16)	1 $\frac{3}{16}$ -18UNEF-2B	$\phi 6.5$ (0.26) to $\phi 9.5$ (0.37)
JL04-2022CK (14)	37.3 (1.47)	34.9 (1.37)	24.3 (0.96)	53.8 (2.12)	15.9 (0.63)	4 (0.16)	1 $\frac{3}{16}$ -18UNEF-2B	$\phi 12.9$ (0.51) to $\phi 15.9$ (0.63)
JL04-2428CK (17)	42.9 (1.69)	42.1 (1.66)	26.2 (1.03)	56.2 (2.21)	18 (0.71)	4.8 (0.19)	1 $\frac{7}{16}$ -18UNEF-2B	$\phi 15$ (0.59) to $\phi 18$ (0.71)

Note Select Cable Clamps marked with an asterisk (*) based on wire diameter

■ CN1 I/O Signal Connectors (CN1)

CN1 connectors are required to connect the host controller to CN1 of the Servopack. CN1 connectors are comprised of a connector and a case.

Configuration

Table 5.21 shows the CN1 connector configuration.

Table 5.21 CN1 Connector

Connector Model	Connector Parts			
	Connector		Case	
	Model	No.	Model	No.
JZSP-CKI9	10150-3000VE *	1	10350-52A0-008 *	1 lot

* Manufactured by Sumitomo 3M Co

External Dimensions

The following figure shows connector and case dimensions

• Connector

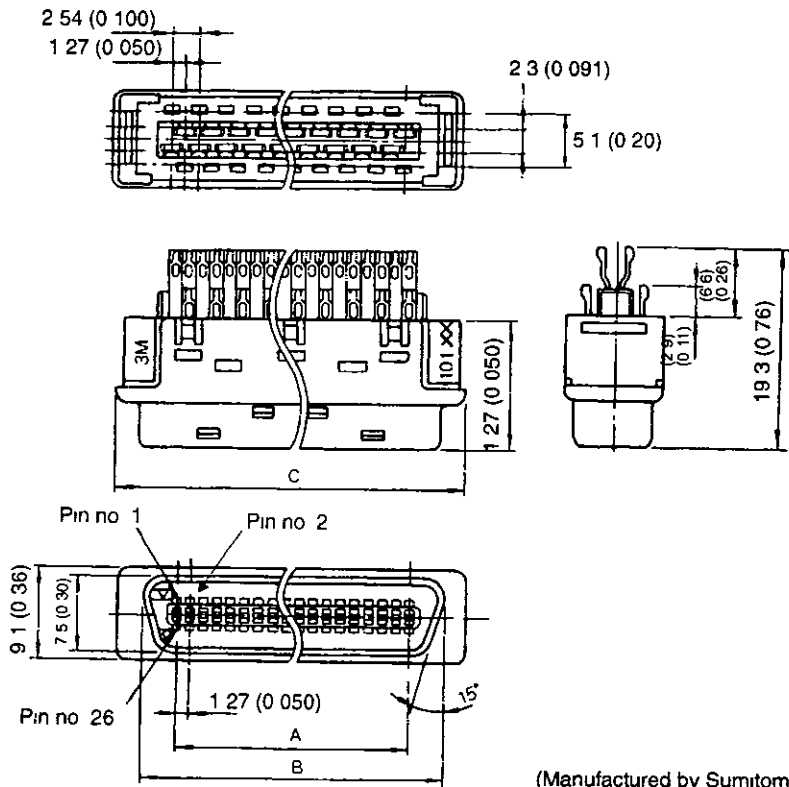

(Manufactured by Sumitomo 3M Co)

Units mm (in)

Connector Model	A	B	C
10150-3000VE	30.48 (1.20)	36.7 (1.44)	41.1 (1.62)



• Case

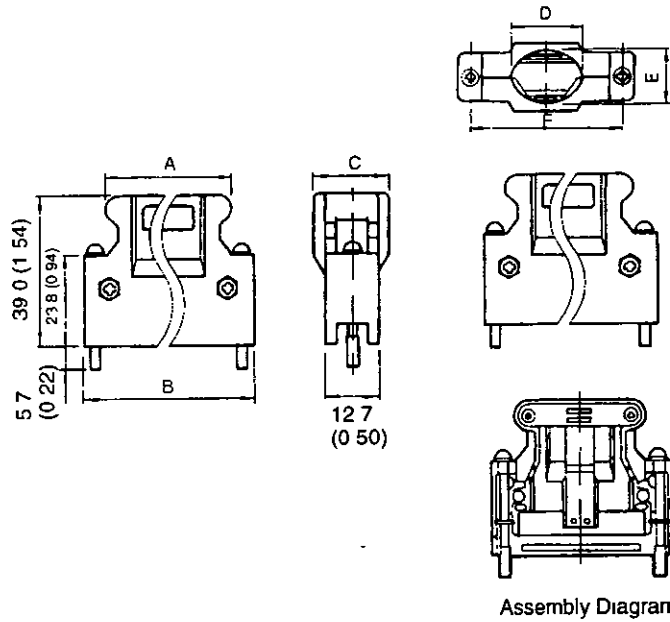

(Manufactured by Sumitomo 3M Co.)

Units: mm (in)

Connector Model	Case Model	A	B	C	D	E	F
10150-3000VE	10350-52A0-008	41.1 (1.62)	52.4 (2.06)	18.0 (0.71)	17.0 (0.67)	14.0 (0.55)	46.5 (1.83)

5.2.4 External Regenerative Resistors

Regenerative resistors for Servopacks are internally or externally mounted as shown in *Table 5 22*. Regenerative resistors can be externally mounted onto all Servopacks. Externally mount a regenerative resistor if regenerative energy exceeds the capacity of the Servopack.

If a regenerative resistor is to be mounted externally, the jumper between B2 and B3 for the internal regenerative resistor must be removed. *Table 5 23* shows examples of regenerative resistors.

Refer to the Design and Maintenance Section of the Σ -II Series SGM□H/SGDM User's Manual (Manual No. SIE-S800-31 2) for more details on the procedure for selecting a regenerative resistor.

Table 5 22 Specifications for Servopack Regenerative Resistors

Applicable Servopack		Specifications for a Regenerative Resistor Mounted in a Servopack		Min Allowable Resistance (Ω)
		Resistance (Ω)	Capacity (W)	
For 200 V	SGDM-A3AD, -A3ADA	—	—	40
	SGDM-A5AD, -A5ADA			
	SGDM-01AD, -01ADA			
	SGDM-02AD, -02ADA			
	SGDM-04AD, -04ADA			
	SGDM-05AD, -05ADA	50	60	
	SGDM-08AD, -08ADA			
	SGDM-10AD, -10ADA			
	SGDM-15AD, 15ADA	30	70	20
	SGDM-20AD, -20ADA	25	140	12
	SGDM-30AD, 30ADA	12.5	140	
	SGDM-50ADA	8	280	8
	SGDM-60ADA	(6 25) *1	(880) *1	5.8
	SGDM-75ADA to -1EADA	(3 13) *2	(1760) *2	2.9

Applicable Servopack		Specifications for a Regenerative Resistor Mounted in a Servopack		Min. Allowable Resistance (Ω)
		Resistance (Ω)	Capacity (W)	
For 100 V	SGDM-A3BD, -A3BDA	-	-	40
	SGDM-A5BD, -A5BDA			
	SGDM-01BD, -01BDA			
	SGDM-02BD, -02BDA			

* 1. The values in parentheses are applicable to the JUSP-RA04 Regenerative Resistor Unit (special option)

* 2. The values in parentheses are applicable to the JUSP-RA05 Regenerative Resistor Unit (special option)

Table 5.23 Examples of External Regenerative Resistors

Manufacturer's Model	Specifications	Manufacturer
RH120	70 W, 1 to 100 Ω	Iwaki Wireless Research Institute
RH150	90 W, 1 to 100 Ω	
RH220	120 W, 1 to 100 Ω	
RH300C	200 W, 1 to 10 k Ω	
RH500	300 W, 10 to 30 Ω	

Note Set the resistance of the regenerative resistor to higher than the minimum allowable resistance for the Servopack

Product Name Configurations

RH120 (N) 10 Ω J

① ② ③

① Model	N indicates non-inductive windings
② Resistance	-
③ Resistor Tolerance	K $\pm 10\%$ J $\pm 5\%$ H $\pm 3\%$

Specifications

Resistor Tolerance	K $\pm 10\%$, J $\pm 5\%$, H $\pm 3\%$
Resistor Temperature Characteristics	± 400 PPM/ $^{\circ}$ C (Up to 20 Ω), ± 260 PPM/ $^{\circ}$ C (20 Ω or higher)
Withstand Voltage	ΔR at 2000 VAC/1 min $\pm(0.1\% + 0.05 \Omega)$
Insulation Resistance	500 VDC 20 M Ω or higher
Short-term Overload	ΔR with 10 times the rated power applied for 5 s $\pm(2\% + 0.05 \Omega)$
Service Life	ΔR in 1000 hours at rated 90 minutes ON and 30 minutes OFF $\pm(5\% + 0.05 \Omega)$

Inflammability	Fire does not occur with 10 times the rated power applied for 1 min
Ambient Temperature Range	-25 to 150 °C

■ Dimensional Drawings

RH120, 150, 220

Lead wire L = 300 (11 81)

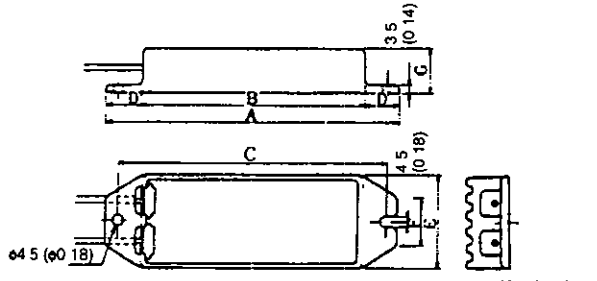

Unit (mm) (in)

	Rated Power	Resistance Range	A	B	C	D	E	F	G
RH120	70 W	1 Ω to 100 Ω	182 (7 17)	150 (5 91)	172 (6 77)	16 (0 63)	42 (1 65)	22 (0 87)	20 (0 79)
RH150	90 W	1 Ω to 100 Ω	212 (8 35)	180 (7 09)	202 (7 95)	16 (0 63)	44 (1 73)	24 (0 94)	30 (1 18)
RH220	120 W	1 Ω to 100 Ω	230 (9 06)	200 (7 87)	220 (8 66)	15 (0 59)	60 (2 36)	24 (0 94)	20 (0 79)

RH220B

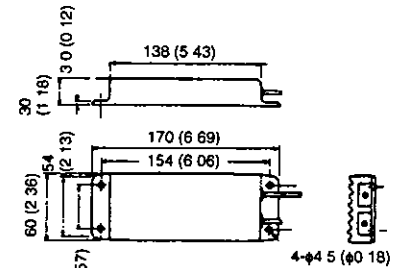

Lead wire L = 500 (19 69)
 Rated power 120 W
 Resistance range 1 Ω to 100 kΩ

RH300C

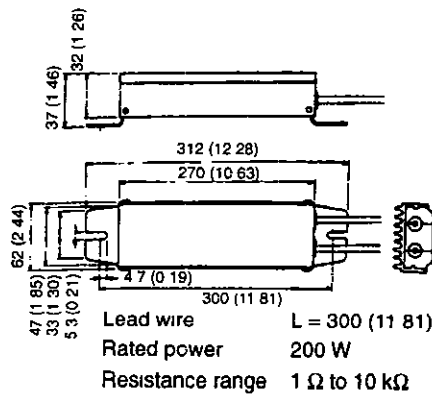

Lead wire L = 300 (11 81)
 Rated power 200 W
 Resistance range 1 Ω to 10 kΩ

RH500

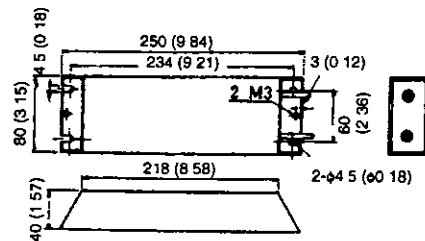

Lead wire L = 450 (17 72)
 Rated power 300 W
 Resistance range 1 Ω to 30 kΩ

5.2.5 Regenerative Resistor Unit

Regenerative resistors for processing regenerative energy are externally mounted on Servopacks (SGDM-60 or higher) used for 5.5 kW or more Servomotors

The following Regenerative Resistor Units are required according to the Servopack model

Servopack Model SGDM-	Regenerative Resistor Unit
60ADA	JUSP-RA04
75ADA to 1EADA	JUSP-RA05

■ Dimensional Drawings

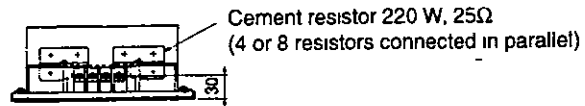
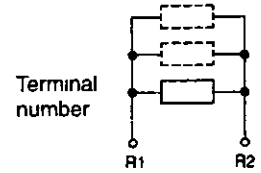
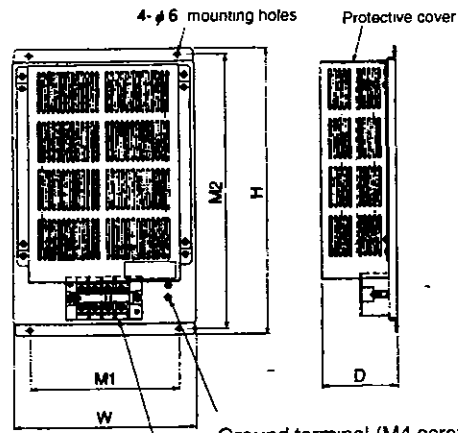

Units mm (

Model	W	H	D	M1	M2	Approx Mass kg (lb)
JUSP-RA04	220 (8 66)	350 (13 8)	92 (3 62)	180 (7 09)	335 (13 2)	4 (8 82)
JUSP-RA05	300 (11 8)	350 (13 8)	95 (3 74)	250 (9 84)	335 (13 2)	7 (15 4)

5.2.6 DC Reactors for Power Supplies Designed for Minimum Harmonics

If necessary for power supplies designed for minimum harmonics, connect a DC reactor between the (+) 1 and (+) 2 terminal of Servopack main circuits. Select a DC reactor that matches the ratings of the Servopack from among those listed in *Table 5.24*

Table 5.24 DC Reactor Specifications

Applicable Servopack		Reactor Specifications		Reactor Model
		Impedance (mH)	Rated Current (A)	
For 200 V	SGDM-A3AD, -A3ADA	—	—	—
	SGDM-A5AD, -A5ADA	—	—	—
	SGDM-01AD, -01ADA	22.0	1.0	X5064
	SGDM-02AD, -02ADA	10.0	1.8	X5063
	SGDM-04AD, -04ADA	4.7	3.5	X5062
	SGDM-05AD, -05ADA	2.0	4.8	X5061
	SGDM-08AD, -08ADA			
	SGDM-10AD, -10ADA			
	SGDM-15AD, -15ADA	1.5	8.8	X5060
	SGDM-20AD, -20ADA			
	SGDM-30AD, -30ADA	1.0	14.0	X5059
	SGDM-50ADA	0.47	26.8	X5068
	For 100 V	SGDM-A3BD, -A3BDA	—	—
SGDM-A5BD, -A5BDA		—	—	—
SGDM-01BD, -01BDA		10.0	1.8	X5063
SGDM-02BD, -02BDA		4.7	3.5	X5062



■ Dimensional Drawings

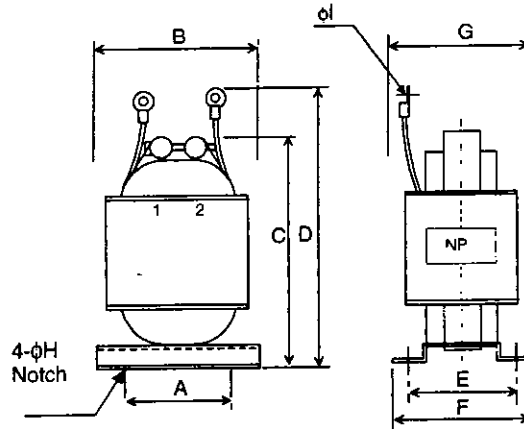

Reactor Model	Dimensions mm (in)									Approximate Mass kg (lb)
	A	B	C	D	E	F	G	φH	φI	
X5064	35 (1.38)	52 (2.05)	80 (3.15)	95 (3.74)	30 (1.18)	40 (1.57)	45 (1.77)	4 (0.16)	4.3 (0.17)	0.5 (1.102)
X5063	35 (1.38)	52 (2.05)	90 (3.54)	105 (4.13)	35 (1.38)	45 (1.77)	50 (1.97)	4 (0.16)	4.3 (0.17)	0.6 (1.323)
X5062	40 (1.57)	59 (2.32)	100 (3.94)	120 (4.72)	40 (1.57)	50 (1.97)	55 (2.17)	4 (0.16)	4.3 (0.17)	0.9 (1.984)
X5061	35 (1.38)	52 (2.05)	80 (3.15)	95 (3.74)	35 (1.38)	45 (1.77)	50 (1.97)	4 (0.16)	4.3 (0.17)	0.5 (1.102)
X5060	40 (1.57)	59 (2.32)	105 (4.13)	125 (4.92)	45 (1.77)	60 (2.36)	65 (2.56)	4 (0.16)	4.3 (0.17)	1.0 (2.21)
X5059	50 (1.97)	74 (2.91)	125 (4.92)	140 (5.51)	35 (1.38)	45 (1.77)	60 (2.36)	5 (0.16)	5.3 (0.21)	1.1 (2.43)
X5068	50 (1.97)	74 (2.91)	125 (4.92)	155 (6.1)	53 (2.09)	66 (2.6)	75 (2.95)	5 (0.16)	6.4 (0.25)	1.9 (4.19)

5.2.7 Brake Power Supplies

Brake power supplies are available for 200-V and 100-V inputs for Servomotors with brakes

- 200-V input: LPSE-2H01
- 100-V input: LPDE-1H01

■ Dimensional Drawings

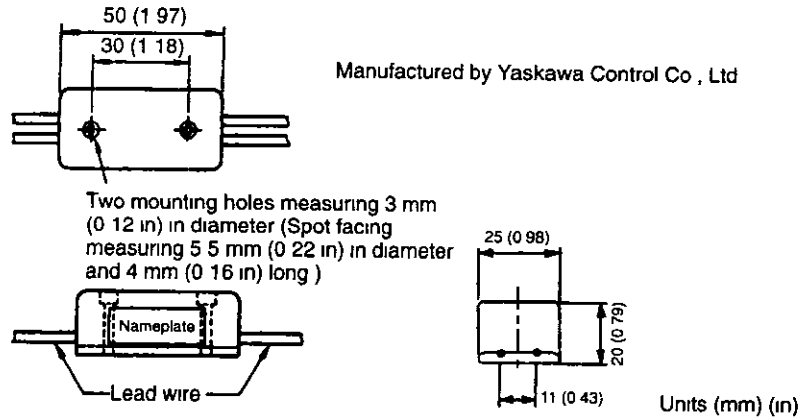

■ Specifications

- Lead wire length: About 500 mm (19.69 in) each
- Max. ambient temperature: 60 °C
- Lead wires: Color coded

AC Input		Brake End
100 V	200 V	
Blue/White	Yellow/White	Red/Black

■ Internal Circuits

The following shows internal circuits for brake power supplies. While it is possible to switch either the AC or the DC side of the power supplies, it is normally safer to switch the AC side.

IMPORTANT

When switching on the DC side, install a surge suppressor near the brake coil to prevent damage to the coil from voltage surges due to DC-side switching.

Internal Circuit for 200-VAC Input (LPSE-2H01)

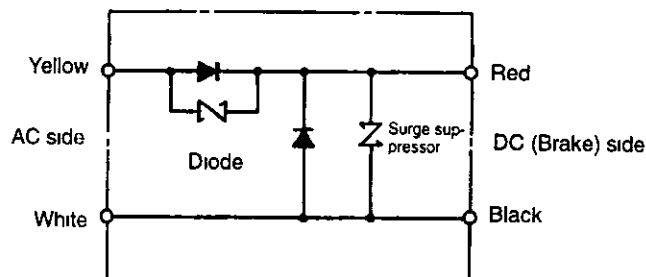

Internal Circuit for 100-VAC Input (LPDE-1H01)

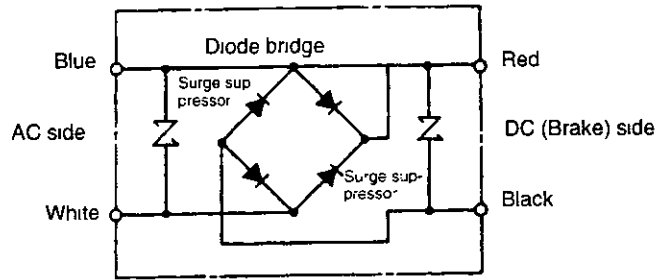

5.2.8 Absolute Encoder Battery

When the power supply of an absolute encoder is OFF, a data backup battery is required. Customers must purchase one of the absolute encoder batteries below.

■ Battery Installed on at the Host Controller End

Model ER6VC3 (lithium battery)

3.6 V 2000 mAh

Manufactured by Toshiba Battery Co., Ltd.

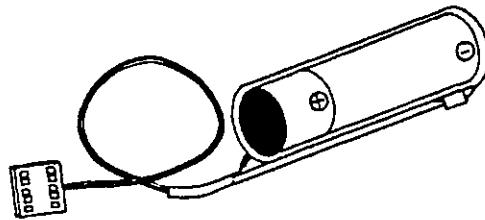

■ Battery Installed at the Servopack

Model JZSP-BA01 (-1) (lithium battery)

(Battery ER 3 V battery made by Toshiba Battery Co., Ltd.)

3.6 V 1000 mAh

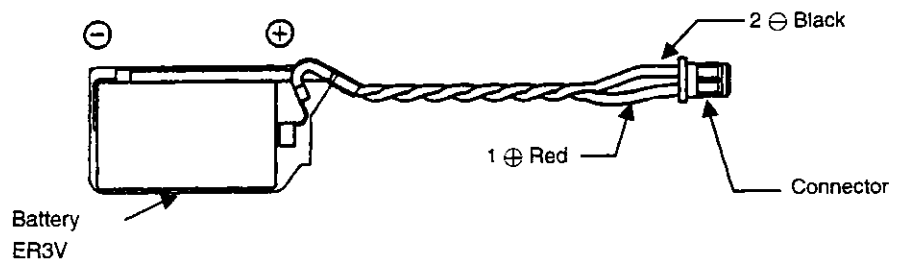

Models	Applicable Servopack Capacity	Length (L)
JZSP-BA01	Max. 5.0 kW	20 mm (0.79 in)
JZSP-BA01-1	6.0 kW to 7.5 kW	50 mm (2 in)

5.2.9 Connector Terminal Block Converter Unit

The Connector Terminal Block Converter Unit is comprised of a CN1 connector and cable. The terminal block numbers match CN1 connector numbers on the Servopack-end connector.

Figure 5.6 shows the Connector Terminal Block Converter Unit.

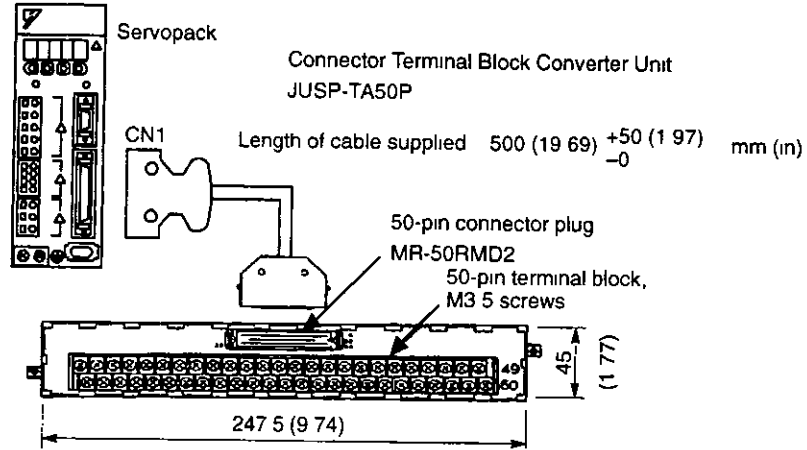

Figure 5.6 Connector Terminal Block Converter Unit Connected to a Servopack



Terminal Block Pin Numbers and Signal Names

Figure 5 7 shows terminal block pin numbers and signal names

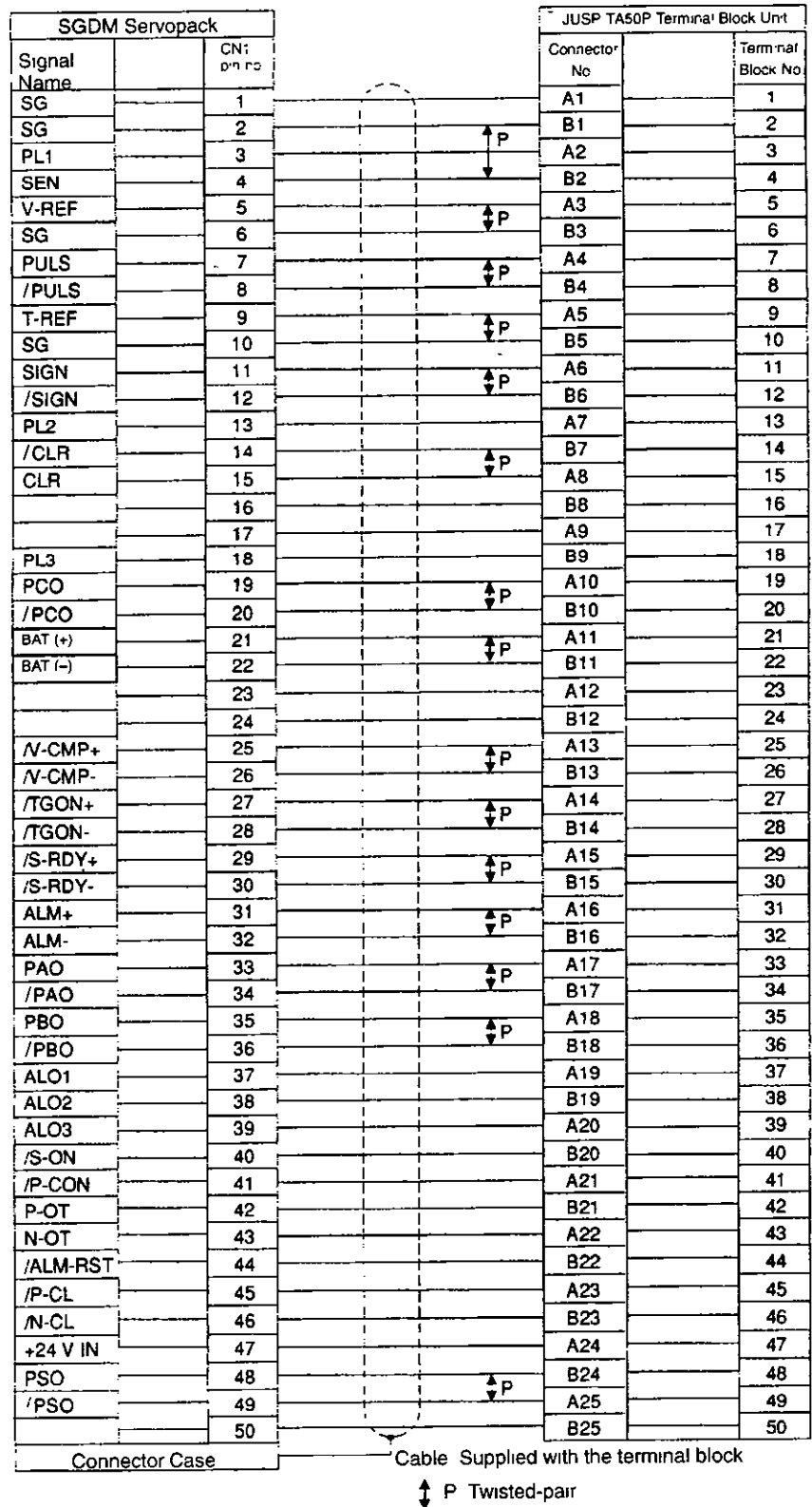

Figure 5 7 Terminal Block Pin Numbers and Signal Names

5.2.10 Encoder Signal Converter Unit

The Encoder Signal Converter Unit converts encoder signal output from the line driver to open collector or voltage pulse output

Table 5 25 shows specifications for the unit

Table 5 25 Encoder Signal Converter Unit Specifications

Model	Receiver Unit			
	LRX-01/A1	LRX-01/A2	LRX-01/A3	LRX-01/A4
Power Supply	12 VDC \pm 10 %, 100 mA		5 VDC \pm 5 %, 100 mA	
Input Signals	Balanced line driver input (RS422)			
Output Signals	Voltage pulse output	Open collector output	Voltage pulse output	Open collector output
Input Signal Level	Voltage differential \geq 0.3 V, built-in terminating resistance 100 Ω			
Output Signal Level	H 10 V min (1 mA) L 0.5 V min (30 mA)	L 0.5 V max (30 mA) withstand voltage 50 V	H 3 V min (1 mA) L 0.5 V min (30 mA)	L 0.5 V max (30 mA) withstand voltage 50 V
Ambient Temperature Range	0 to +60 $^{\circ}$ C			
IC Used	Receiver IC AM26LS32C or the equivalent			

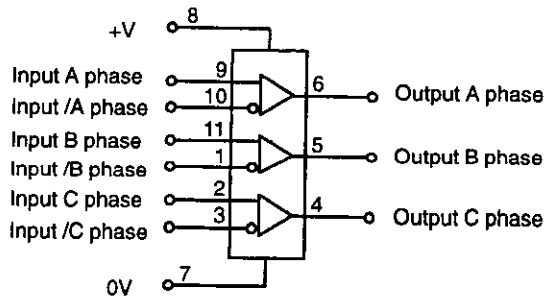
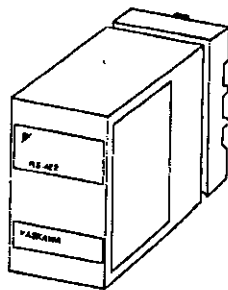

Dimensional Drawings

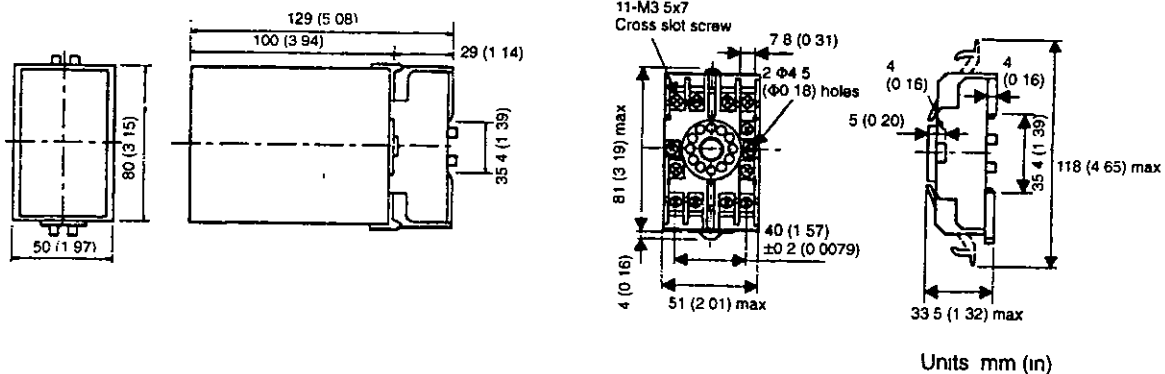

5.2.11 Cables for Connecting PCs to a Servopack

Special cables are used to connect a PC to a Servopack. With these cables, user constants can be monitored and set with a PC.

Communications software that controls the Servodrive from a PC is available from Yaskawa. Contact your Yaskawa representative for more details, and operate the software as described in the manual supplied.

■ D-sub, 25-pin Connector Cable

Connecting a Personal Computer to a Servopack

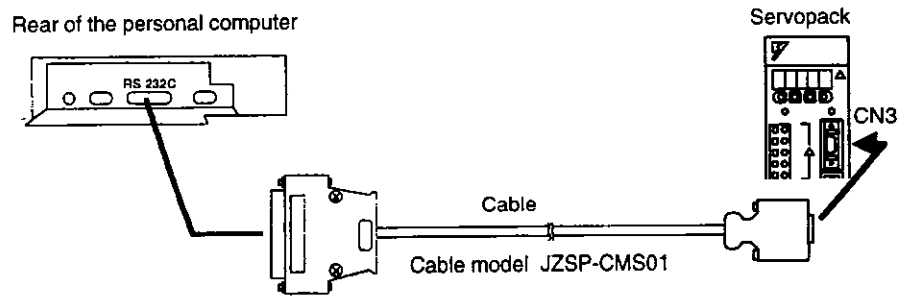

Cable Configuration

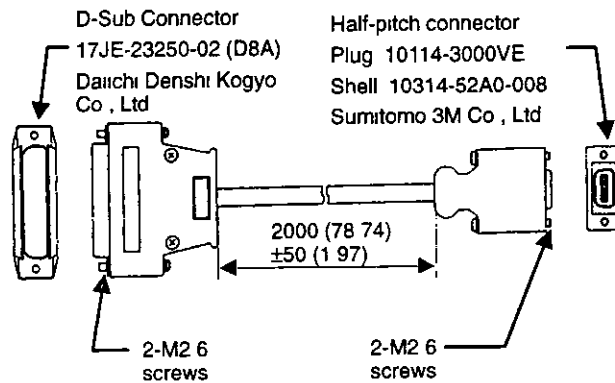

Communications Specifications

The communications specifications are as follows

- Baud Rate 9600 bps
- Number of Bits
 - Start 1 bit
 - Data 7 bits
 - Stop 1 bit
 - Parity 1 bit (even)
- Synchronization Method Start-Stop
- XON/XOFF Control None
- Shift Control None
- Communications Method Semi-duplex

Connection Circuits

• With an RS-232C Port

Maximum cable length is 2 m (6 56 ft) In this case, the connection circuit is as follows

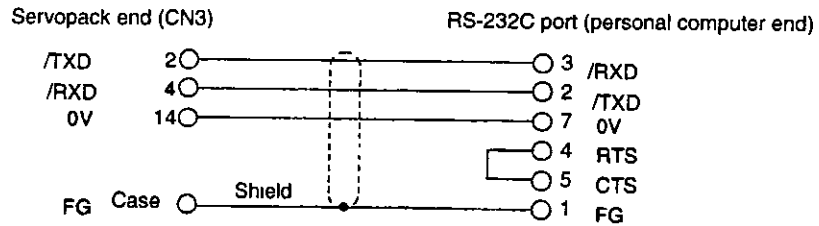

• With an RS-422A Port

The Servopack can also be connected to an RS-422A port In this case, the connection circuit is as follows

- Transmission Distance 30 m (98 4 ft) max
- Transmission System RS-422A

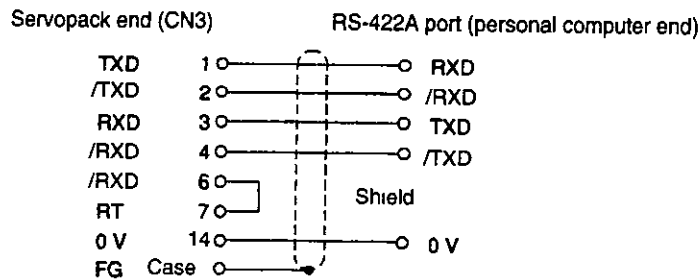

● Terminal Arrangement at the Servopack End

Table 5.26 Connector Pin Numbers and Signal Names

Pin No	Signal Name	Signal Circuit Name	Signal Direction
1	TXD	Transmit data (not inverted)	P ^{*1} ← S ^{*2}
2	/TXD	Transmit data (inverted)	P ← S
3	RXD	Receive data (not inverted)	P → S
4	/RXD	Receive data (inverted)	P → S
5	OPH	Reserved pin	-
6	/RXD	Short pins 6 and 7 to insert a 220 Ω terminating resistance between RXD and *RXD	
7	RT		
8	TXD	Transmit data (not inverted)	P ← S
9	/TXD	Transmit data (inverted)	P ← S
10	RXD	Receive data (not inverted)	P → S
11		Reserved pin	# ^{*3}
12		Reserved pin	# ^{*3}
13	5VPP	Reserved pin	-
14	GND	Signal ground 0 V	-

* 1. P Personal computer

* 2. S Servopack

* 3. # Reserved terminal (Leave open)

Note Fold back and clamp the cable shield at both ends

■ Other Cables for Connecting Personal Computers

Yaskawa also provides cables for connecting NEC PC98 Series and IBM PC compatible to a Servopack

D-sub, 9-pin Connector Cable for IBM PC Compatible

● Cable Configuration

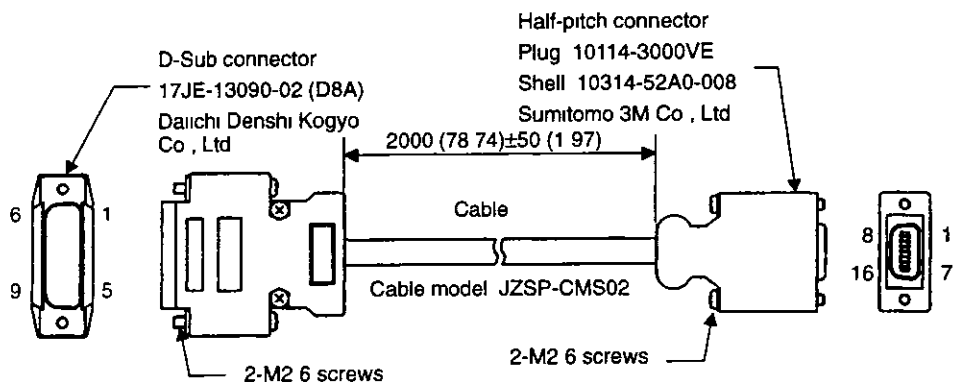

● **Connecting Circuit**

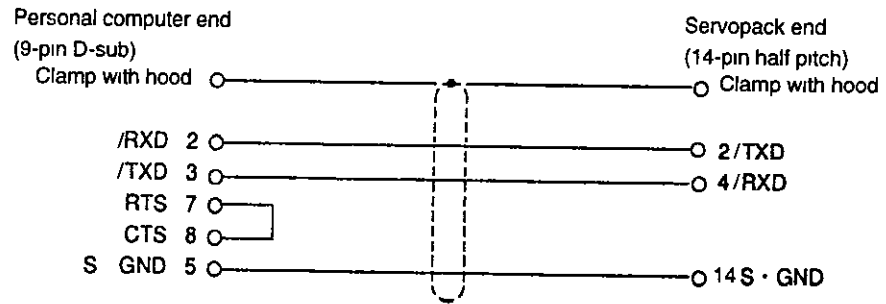

14-pin Half-pitch Connector Cable for NEC PC-98 Series PC

● **Cable Configuration**

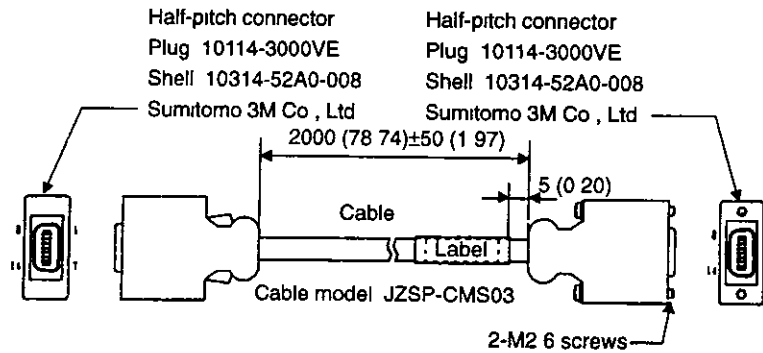

● **Connecting Circuit**

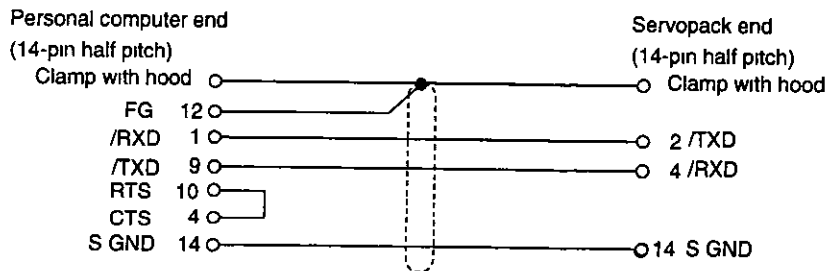

5.2.12 Personal Computer Monitoring Software

By connecting a PC and a Servopack, user constants can be set up, operation can be execute and status and alarms can be displayed The following is a function tree for personal comput monitoring

Function Tree for Personal Computer Monitoring

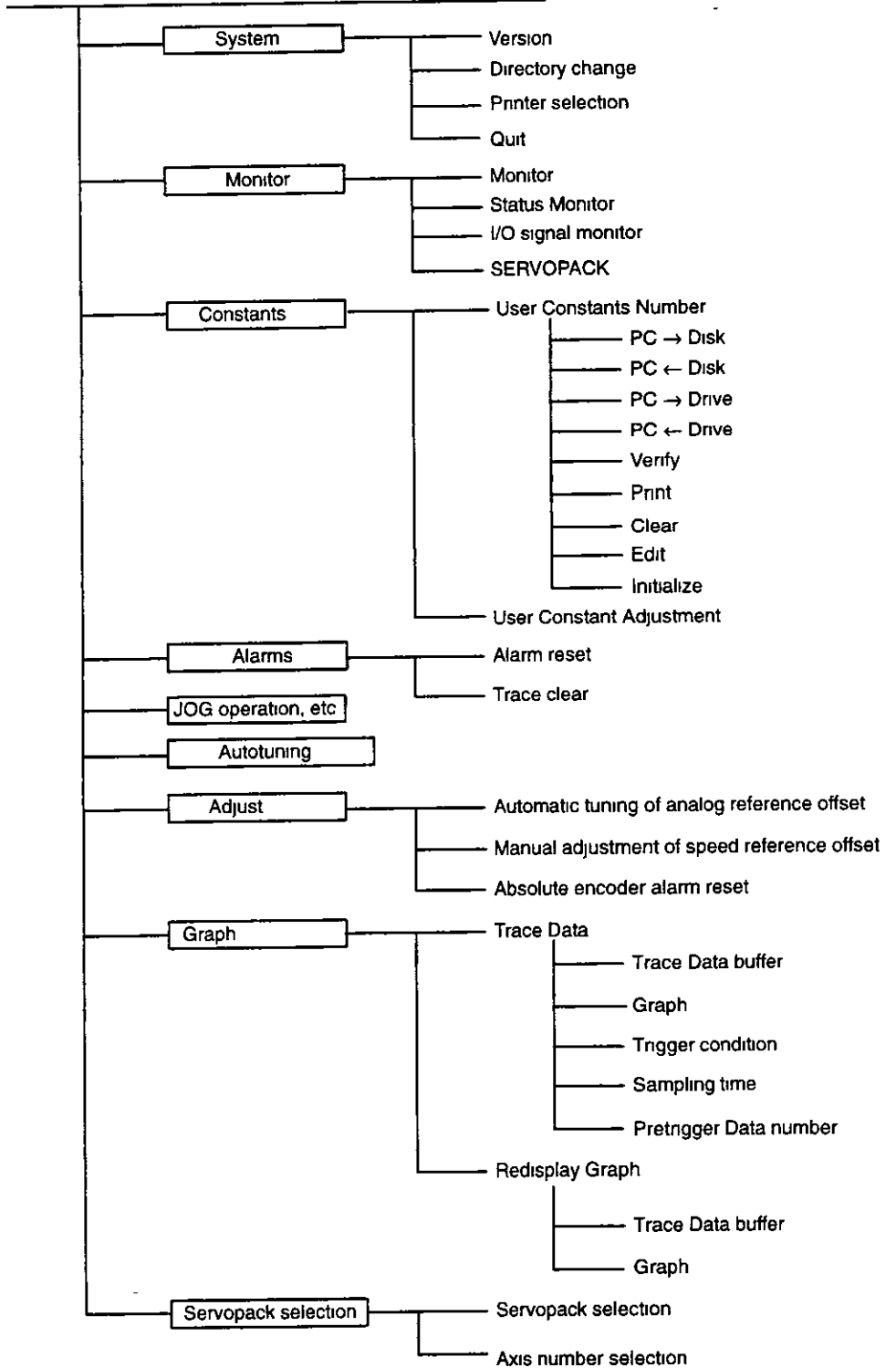

5.3 Peripheral Devices

5.3.1 Molded-case Circuit Breaker (MCCB)

A molded-case circuit breaker is used to protect the power supply line. The customer must provide a molded-case circuit breaker with an appropriate capacity.

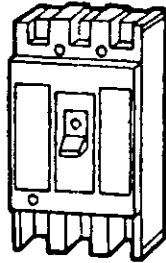

- Recommended Product
Ground fault detector for Servomotor protection
manufactured by Mitsubishi Electric Co., Ltd.
Model MN50-CF

5.3.2 Noise Filter

A noise filter is installed to eliminate external noise from the power supply line. Select one of the following single or three-phase noise filters based on Servopack capacity. See *5.1 Cable Specifications and Peripheral Devices* for more details on selecting current capacity for a noise filter.

■ Dimensional Drawing of Recommended Noise Filters

Two types of noise filters are recommended.

SUP-P H-EPR- Series Noise Filter: Manufactured by Okaya Electric Industries Co., Ltd.

Model	Rated Current	Voltage
SUP-P5H-EPR-4	5 A	Single-phase 250 VAC
SUP-P8H-EPR-4	8 A	
SUP-P10H-EPR-4	10 A	
SUP-P15H-EPR-4	15 A	

• Dimensional Drawing (Screw Terminal Type)

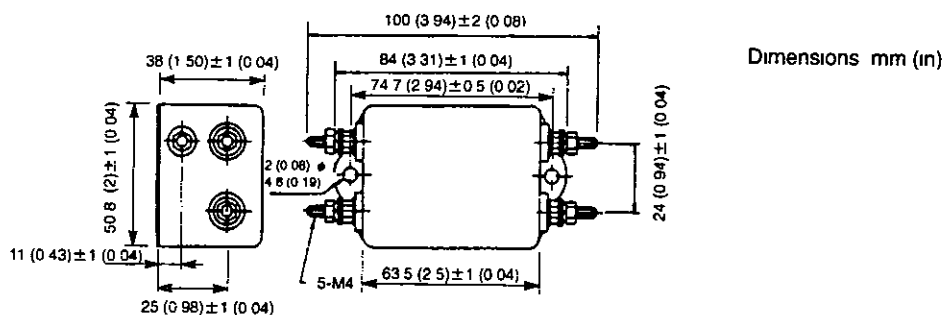

LF-3□00 Series Noise Filter: Manufactured by Tokin Corp.

Model	Dimensions mm (in)					Rated Current	Voltage
	W (max)	H	D (max)	M1	M2		
LF-3200	252 (9.92)	110 (4.33)	62 (2.44)	150 (5.91)	100 (3.94)	20 A	Three-phase 250 VAC
LF-3300	252 (9.92)	110 (4.33)	62 (2.44)	150 (5.91)	100 (3.94)	30 A	
LF-3400	269 (10.59)	149 (5.87)	75 (2.95)	150 (5.91)	139 (5.47)	40 A	
LF-3500	269 (10.59)	149 (5.87)	62 (2.44)	150 (5.91)	139 (5.47)	50 A	
LF-3600	419 (16.50)	220 (8.66)	117 (4.61)	300 (11.81)	200 (7.87)	60 A	

• **Dimensional Drawing**

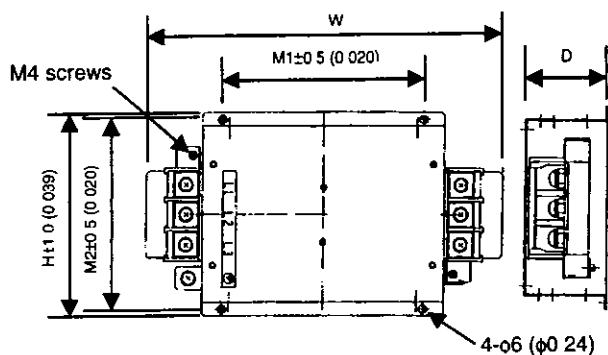

5.3.3 Magnetic Contactor

A magnetic contactor turns ON and OFF the servo. Be sure to attach a surge suppressor to the excitation coil of the magnetic contactor.

Select a magnetic contactor based on the current capacity of the Servopack. For multiple servo systems, select a contactor based on total current capacity.

Table 5.27 shows external dimensions and terminal symbols for the magnetic contactor.

Table 5.27 External Dimensions and Terminal Symbols for the Magnetic Contactor

100/200 V Servopacks

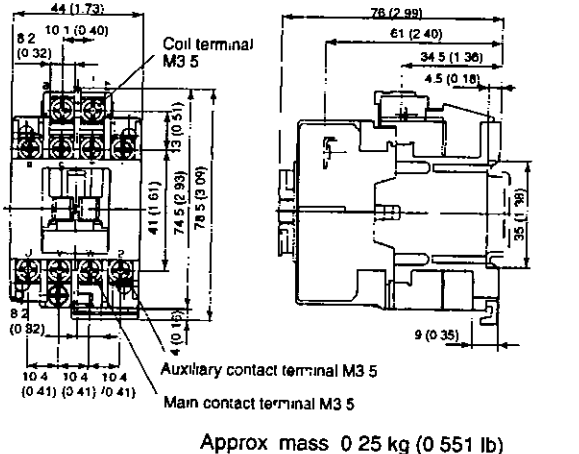
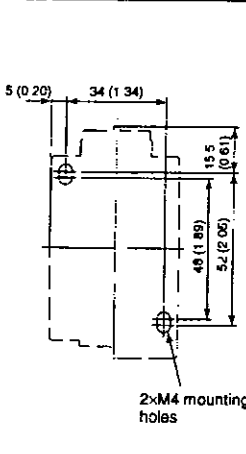
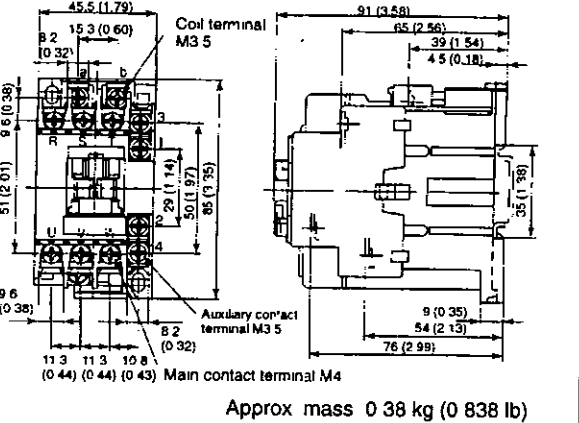
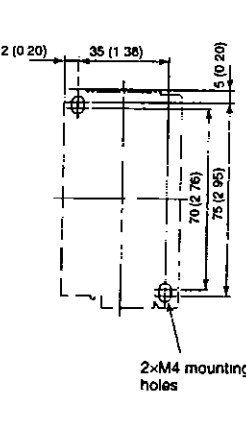
Model	External Dimensions [mm (in)]	Mounting Hole Dimensions [mm (in)]	Terminal Symbols
HI-11J HI-14J	 <p>Coil terminal M3 5</p> <p>Auxiliary contact terminal M3 5</p> <p>Main contact terminal M3 5</p> <p>Approx. mass 0.25 kg (0.551 lb)</p>	 <p>2xM4 mounting holes</p>	<p>Auxiliary NO contact</p> <p>a[A1] — o — A2b</p> <p>R 1 S 3 T 5 1 13</p> <p>U 2 V 4 W 6 2 14</p> <p>Auxiliary NC contact</p> <p>a[A1] — o — A2b</p> <p>R 1 S 3 T 5 1 11</p> <p>U 2 V 4 W 6 2 12</p>
HI-15J HI-18J	 <p>Coil terminal M3 5</p> <p>Auxiliary contact terminal M3 5</p> <p>Main contact terminal M4</p> <p>Approx. mass 0.38 kg (0.838 lb)</p>	 <p>2xM4 mounting holes</p>	<p>Auxiliary NO contact/ Auxiliary NC contact</p> <p>a[A1] — o — A2b</p> <p>R 1 S 3 T 5 1 21 3 11</p> <p>U 2 V 4 W 6 2 23 4 12</p>



Specifications and Dimensional Drawings for Peripheral Devices

5 3 3 Magnetic Contactor

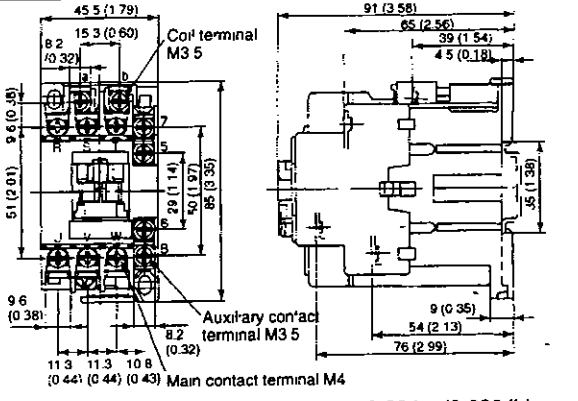
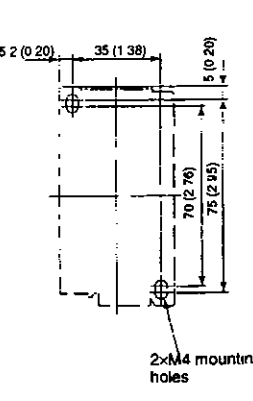
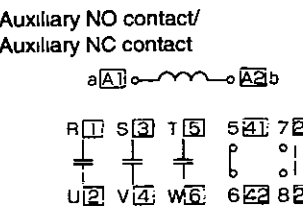
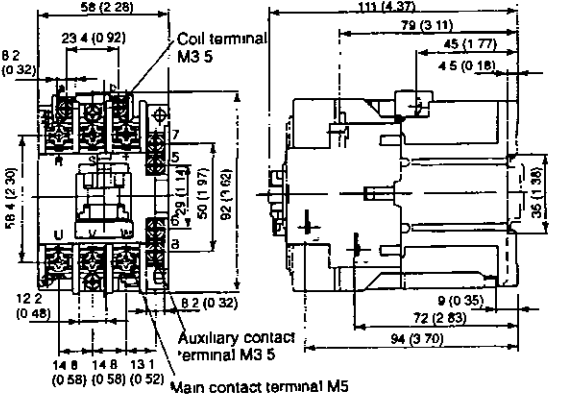
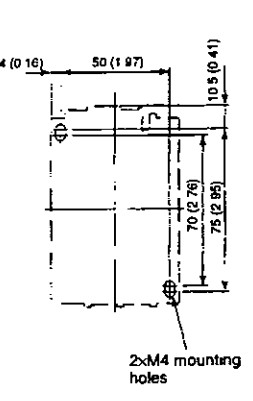
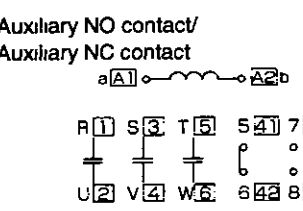
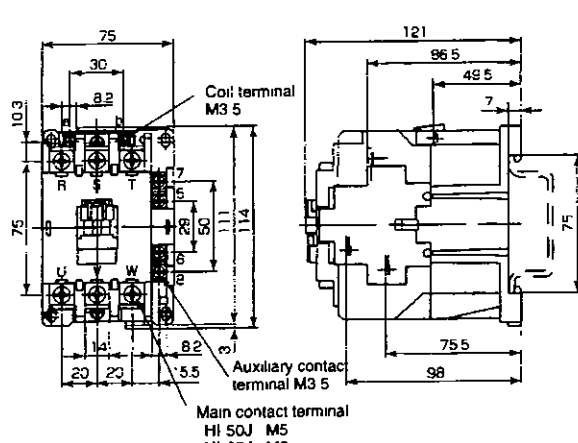
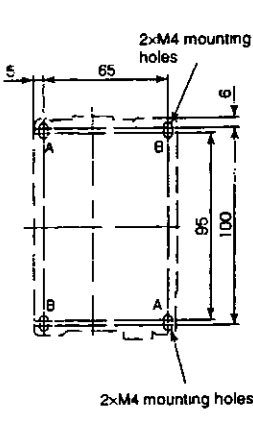
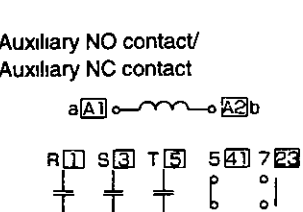
Model	External Dimensions [mm (in)]	Mounting Hole Dimensions [mm (in)]	Terminal Symbols
<p>HI-20J</p>	 <p>Approx mass 0.38 kg (0.838 lb)</p>	 <p>2xM4 mounting holes</p>	<p>Auxiliary NO contact/ Auxiliary NC contact</p> 
<p>HI-25J HI-35J</p>	 <p>Approx mass 0.68 kg (1.499 lb)</p>	 <p>2xM4 mounting holes</p>	<p>Auxiliary NO contact/ Auxiliary NC contact</p> 
<p>HI-50J HI-65J</p>	 <p>Approx mass 1.1 kg (2.425 lb)</p>	 <p>2xM4 mounting holes</p>	<p>Auxiliary NO contact/ Auxiliary NC contact</p> 

* The magnetic contactor is manufactured by Yaskawa Controls

5.3.4 Surge Suppressor

Attach a surge suppressor to the excitation coil of the magnetic contactor to prevent power supply noise

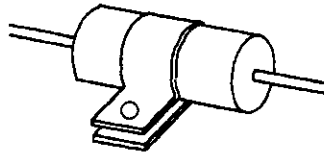

- Recommended Product Spark Killer manufactured by Okaya Electric Industries Co., Ltd

Model CR50500BL (For 250 VAC)
 Static electricity capacity 0.5 μ F \pm 20%
 Resistance 50 Ω (1/2 W) \pm 30%

5.3.5 Variable Resistor for Speed Setting

This variable resistor provides speed references by applying speed reference voltage from the external power supply across CN1 pins 1 and 5 as well as 1 and 6

■ Dimensional Drawings

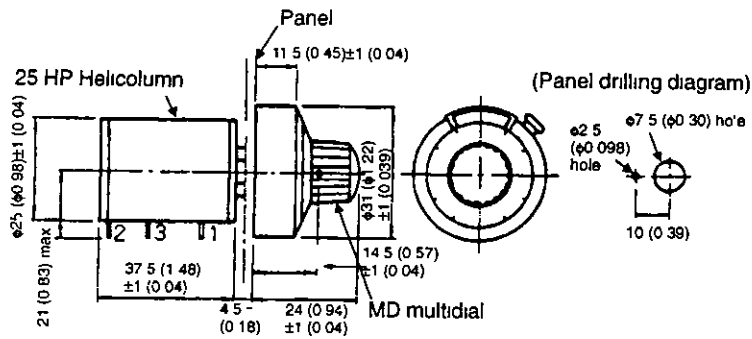

■ Connection to an External Power Supply

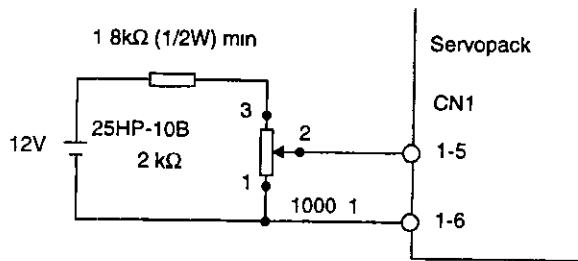

- 25 HP-10B Multi-wrap variable resistor with MD10-30B4 dial manufactured by Sakae Tsushin Kogyo Co., Ltd

INDEX

A

absolute encoder batteries, 5 -44
axis end specifications, 1 -3

B

ball screw, 1 -9
brake power supplies, 5 -42
 internal circuits, 5 -43
braking characteristics, 5 -8

C

cables
 14-pin half-pitch connector, 5 -51
 CN1 for I/O signals, 5 -16
 D-sub, 24-pin connector, 5 -48
 D-sub, 9-pin connector, 5 -50
 for connecting PC to Servopack, 5 -48
 for connecting personal computers, 5 -50
 for encoders, 5 -13
 for Servomotors with brakes, 5 -12
 for Servomotors without brakes, 5 -11
 models and lengths, 5 -10, 5 -16
 Servomotors, 5 -11
 specifications, 4 -44, 4 -46, 4 -64, 4 -66, 4 -67, 4 -84, 4 -86,
 4 -93, 5 -2, 5 -9, 5 -16
 types, 5 -4
 with encoder loose leads, 5 -14
 with L-shaped plugs, 5 -14
 with Servopack and Servomotor connectors, 5 -13
 with Servopack connectors, 5 -14
 with straight plugs, 5 -14
 without connectors, 5 -15

caution, definition of, iii

CN1 I/O signal connectors, 5 -34

communications specifications, 5 -49

Connector Terminal Block Converter Unit, 5 -45

connectors

 cables for CN1 and CN2, 5 -5
 for IP67 environments, 5 -25
 kits, 5 -16
 Servomotors, 5 -13, 5 -18, 5 -24
 Servopacks, 4 -98, 4 -107, 5 -5, 5 -13

control I/O signal connector, 5 -5

counterweight, 1 -9

D

DC reactors

 dimensional drawings, 5 -42
 specifications, 5 -41

detector connectors, 4 -44, 4 -64, 4 -84, 4 -93

Digital Operator, 5 -9

 connection circuits, 5 -10

dimensional drawings, 4 -2

 brake power supplies, 5 -43

 DC reactors, 5 -42

 Encoder Signal Converter Unit, 5 -47

 noise filters, 5 -53

 peripheral devices, 5 -1

 regenerative resistor, 5 -39

 Regenerative Resistor Unit, 5 -40

 Servopacks, 4 -97

 SGMAH Servomotors, 4 -3

 SGMDH Servomotors, 4 -91

 SGMGH Servomotors, 4 -42, 4 -62

 SGMPH Servomotors, 4 -25

 SGMSH Servomotors, 4 -82

 variable resistors, 5 -57

dimensions

 connectors and case, 5 -35

 Servopacks, 4 -97

 SGMAH Servomotors, 4 -8, 4 -10, 4 -12, 4 -14, 4 -17, 4 -19,
 4 -21, 4 -23

 SGMPH Servomotors, 4 -30, 4 -33, 4 -36, 4 -39, 4 -40

direction of rotation, Servomotors, 2 -60

duty cycle, 1 -10

E

Encoder Signal Converter Unit, 5 -47

encoders

 batteries, 5 -44

 cable connectors, 5 -18, 5 -20

 cables, 5 -13

G

gears, 1 -2

 lubrication, 2 -35, 2 -45

 ratios, 1 -5

 types, 1 -5

H

holding brakes
 electrical specifications. 2 -3, 2 -17
 explanation, 2 -3
hot start 3 -14

I

impact resistance. Servomotors. 2 -60
IP67 environments. 5 -25

L

load moment of inertia
 allowable at motor shaft, 3 -16
 Servopacks, 3 -15

M

magnetic contactors, 5 -55
manuals. related. vii
MCCB. 5 -53
mechanical tolerance. Servomotors, 2 -60
model numbers
 Servomotors. 1 -2
 Servopacks, 1 -11
monitoring software, 5 -52
mounting direction. Servomotors. 2 -61

N

noise data 2 -14, 2 -27
noise filters. 5 -6, 5 -53

O

offline terminals, 5 -2, 5 -3
online terminals. 5 -2, 5 -3
overhanging loads. 3 -19
overload characteristics, Servopacks. 3 -14
overvoltage alarm. 3 -15

P

peripheral devices, 5 -53
 dimensional drawings, 5 -1
 ratings and specifications, 5 -2
 selecting, 1 -14
 specifications. 5 -1
 types and capacities. 5 -6
PG signal connector. 5 -5
positioning time, 1 -10

R

rack and pinion, 1 -9
radial load, allowable, 2 -58
ratings. Servomotors, 2 -2
regeneration overload alarm, 3 -15
regenerative resistor. 3 -15, 3 -16
 dimensional drawings, 5 -39
 external, 5 -37
 specifications, 5 -38
Regenerative Resistor Unit, 5 -39
 dimensional drawings, 5 -40
related manuals, vii
reverse signals. indication of, viii
roll feeder. 1 -10
rotor, 1 -10
RS-232C port. 5 -49
RS-422 A port, 5 -49

S

safety information. iii
serial encoders. 1 -3, 1 -4, 4 -29
Servomotors
 cables, 5 -11
 capacity, 1 -2, 1 -4, 1 -9, 1 -11
 dimensional drawings, 4 -2
 direction of rotation. 2 -60
 impact resistance, 2 -60
 lead specifications, 4 -17, 4 -24, 4 -28, 4 -35, 4 -41
 main circuit cable connectors, 5 -19, 5 -21
 mechanical characteristics. 2 -58
 mechanical tolerance, 2 -60
 model numbers. 1 -2
 mounting direction, 2 -61
 overhanging loads, 3 -19
 ratings, 2 -2
 regenerative brake, 3 -19
 selecting, 1 -2
 selection flowchart. 1 -6

- specifications, 2 -2
 - vibration resistance, 2 -61
 - with gears, 1 -4
- Servopacks**
- absolute encoder battery, 5 -44
 - applicable Servomotors, 1 -12
 - base-mounted, 4 -98
 - cables, 5 -4
 - connectors, 4 -98, 4 -107, 5 -5
 - dimensional drawings, 4 -97
 - duct-ventilated, 4 -112
 - load inertia, 3 -15
 - model numbers, 1 -11
 - overload characteristics, 3 -14
 - rack-mounted, 4 -106
 - ratings and specifications, 3 -2, 3 -7
 - regenerative resistor, 3 -15, 3 -16
 - selecting, 1 -11
 - starting and stopping times, 3 -15
 - wire sizes, 5 -2
- SGMAH Servomotors**
- cable specifications, 5 -11, 5 -13
 - dimensional drawings, 4 -3
 - noise data, 2 -14
 - ratings and specifications, 2 -2, 2 -7, 2 -11, 2 -20
 - Servopack combination specifications, 3 -2, 3 -6
 - specifications
 - encoder plug, 4 -7
 - lead, 4 -7
 - motor plug, 4 -7
 - torque-motor speed characteristics, 2 -5
 - with backlash gears, 2 -7
 - dimensions, 4 -10, 4 -14, 4 -19, 4 -23
 - with brakes, 5 -12
 - with non-backlash gears, 2 -11
 - dimensions, 4 -8, 4 -12, 4 -17, 4 -21
 - without brakes, 4 -8, 5 -11
 - without gears, 2 -2
- SGMDH Servomotors**
- dimensions, 4 -91
 - ratings and specifications, 2 -55
- SGMGH Servomotors**
- cable specifications, 4 -44, 4 -46, 4 -64, 4 -66, 4 -67, 5 -11, 5 -14
 - connectors, 5 -19
 - dimensions, 4 -42, 4 -62, 4 -65, 4 -68, 4 -77, 4 -87
 - gear lubrication, 2 -35, 2 -45
 - ratings and specifications, 2 -29, 2 -33, 2 -36, 2 -39, 2 -43, 2 -46
 - Servopack combination specifications, 3 -4
 - torque-motor speed characteristics, 2 -31, 2 -41, 2 -57
 - with backlash gears, 2 -33, 2 -43
 - with brakes, 4 -45, 4 -65, 5 -12
 - with gears, 4 -48, 4 -68
 - with non-backlash gears, 2 -36, 2 -46
 - with non-backlash gears, 4 -58, 4 -77, 4 -87
 - without brakes, 4 -48, 4 -58, 4 -68, 4 -77, 4 -87, 5 -11
 - without gears, 2 -29, 2 -39
- SGMPH Servomotors**
- cable specifications, 5 -13
 - dimensional drawings, 4 -25
 - noise data, 2 -27
 - ratings and specifications, 2 -16, 2 -24
 - Servopack combination specifications, 3 -3, 3 -6
 - specifications
 - encoder plug, 4 -28
 - motor plug, 4 -28
 - torque-motor speed characteristics, 2 -18
 - with backlash gears, 2 -20
 - dimensions, 4 -33, 4 -39, 4 -40
 - with brakes, 4 -36
 - with non-backlash gears, 2 -24
 - dimensions, 4 -30, 4 -36
 - without brakes, 4 -30
 - without gears, 2 -16
- SGMSH Servomotors**
- cable specifications, 4 -84, 4 -86, 4 -93, 5 -14
 - connectors, 5 -19
 - dimensions, 4 -82, 4 -85
 - ratings and specifications, 2 -50, 2 -53
 - Servopack combination specifications, 3 -5
 - torque-motor speed characteristics, 2 -52
 - with brakes, 4 -85
 - with holding brake, 2 -55
 - with non-backlash gears, 2 -53
 - without gears, 2 -50
- shaft end specifications, 1 -5
- special options, 5 -9
- specifications
- axis end, 1 -3
 - brake power supplies, 5 -43
 - cables, 4 -44, 4 -46, 4 -64, 4 -66, 4 -67, 4 -84, 4 -86, 4 -93, 5 -2, 5 -10
 - communications, 5 -49
 - DC reactors, 5 -41
 - encoder plug, 4 -7, 4 -28
 - holding brakes, 2 -3, 2 -17
 - machine, 1 -9
 - motor plug, 4 -7, 4 -28
 - peripheral devices, 5 -1, 5 -2
 - regenerative resistors, 5 -38
 - Servomotors, 2 -2
 - Servopack/Servomotor combinations, 3 -2
 - shaft end, 1 -5
- surge suppressors, 5 -57

T

- terminal block, pin numbers and signal names, 5 -46
- terminals, 5 -2, 5 -3
 - arrangement at Servopack, 5 -50
- thrust load, allowable, 2 -58
- tuning belt, 1 -9
- torque limit, 3 -15

torque-motor speed characteristics
SGMAH Servomotors. 2 -5
SGMGH Servomotors. 2 -31, 2 -41, 2 -57
SGMPH Servomotors, 2 -18
SGMSH Servomotors. 2 -52

V

variable resistors. 5 -57

vibration resistance, Servomotors. 2 -61

W

wiring
precautions, 5 -2
wire sizes. 5 -2

Σ-II Series SGM□H/SGDM

USER'S MANUAL

Servo Selection and Data Sheets

TOKYO OFFICE

New Pier Takeshiba South Tower 1-16 1 Kaigan, Minatoku Tokyo 105-6891 Japan
Phone 81 3 5402 4511 Fax 81-3-5402-4580

YASKAWA ELECTRIC AMERICA, INC

2121 Norman Drive South Waukegan, IL 60085, U S A.
Phone 1 847-887 7000 Fax 1-847-887-7370

MOTOMAN INC HEADQUARTERS

805 Liberty Lane West Carrollton OH 45449, U S A
Phone 1 937-847-6200 Fax 1-937-847-6277

YASKAWA ELÉTRICO DO BRASIL COMÉRCIO LTDA.

Avenida Fagundes Filho, 620 Barro Saude-Sao Paulo SP Brazil CEP 04304-000
Phone 55 11-5071 2552 Fax 55-11-5581-8795

YASKAWA ELECTRIC EUROPE GmbH

Am Kronberger Hang 2 65824 Schwalbach, Germany
Phone 49-6196-569-300 Fax 49-6196-888 301

Motoman Robotics Europe AB

Box 504 S38525 Torsas, Sweden
Phone 46-486-48800 Fax 46-486-41410

Motoman Robotec GmbH

Kammerfeldstraße 1 85391 Allershausen, Germany
Phone 49-8166-900 Fax 49-8166-9039

YASKAWA ELECTRIC UK LTD

1 Hunt Hill Orchardton Woods Cumbemauld G68 9LF United Kingdom
Phone 44 1236-735000 Fax 44 1236-458182

YASKAWA ELECTRIC KOREA CORPORATION

Kipa Bldg #1201 35-4 Youdo-dong Yeongdongpo-Ku Seoul 150-010 Korea
Phone 82 2 784 7844 Fax 82-2 784-8495

YASKAWA ELECTRIC (SINGAPORE) PTE LTD

151 Lorong Chuan #04-01 New Tech Park Singapore 556741, Singapore
Phone 65-282-3003 Fax 65 289-3003

YASKAWA ELECTRIC (SHANGHAI) CO., LTD

4F No 18 Aona Road, Waigaoqiao Free Trade Zone Pudong New Area Shanghai 200131 China
Phone 86 21 5866-3470 Fax 86 21 5866-3869

YATEC ENGINEERING CORPORATION

Shen Hsiang Tang Sung Chiang Building 10F 146 Sung Chiang Road Taipei, Taiwan
Phone 886-2-2563-0010 Fax 886-2-2567-4677

YASKAWA ELECTRIC (HK) COMPANY LIMITED

Rm 2909 10 Hong Kong Plaza 186-191 Connaught Road West, Hong Kong
Phone 852-2803-2385 Fax 852-2547 5773

BEIJING OFFICE

Room No 301 Office Building of Beijing International Club 21
Jianguomenwai Avenue Beijing 100020, China
Phone 86-10-6532-1850 Fax 86-10-6532-1851

TAIPEI OFFICE

Shen Hsiang Tang Sung Chiang Building 10F 146 Sung Chiang Road Taipei Taiwan
Phone 886 2 2563-0010 Fax 886 2 2567-4677

SHANGHAI YASKAWA-TONGJI M & E CO., LTD

27 Hui He Road Shanghai China 200437
Phone 86 21 6531 4242 Fax 86 21-6553-6060

BEIJING YASKAWA BEIKE AUTOMATION ENGINEERING CO., LTD

30 Xue Yuan Road Haidian, Beijing P R China Post Code 100083
Phone 86-10-6233 2782 Fax 86-10-6232 1536

SHOUGANG MOTOMAN ROBOT CO., LTD

7 Yongchang-North Street Beijing Economic Technological Investment & Development Area,
Beijing 100076, P R China
Phone 86 10-6788-0551 Fax 86 10-6788-2878



YASKAWA

YASKAWA ELECTRIC CORPORATION

Specifications are subject to change without notice
for ongoing product modifications and improvements

MANUAL NO SIE-S800-31 1D
© Printed in Japan October 2000 98-2
99-7③
97 23059 97 23060 97 71094