

Σ SERIES SGM/DR1

AC SERVO DRIVES FOR SPEED·POSITION CONTROL

SERVOMOTOR : TYPES SGM- A31 , SGM- B31
SERVOPACK : TYPES DR1- AC, DR1- BC

efesotomasyon.com

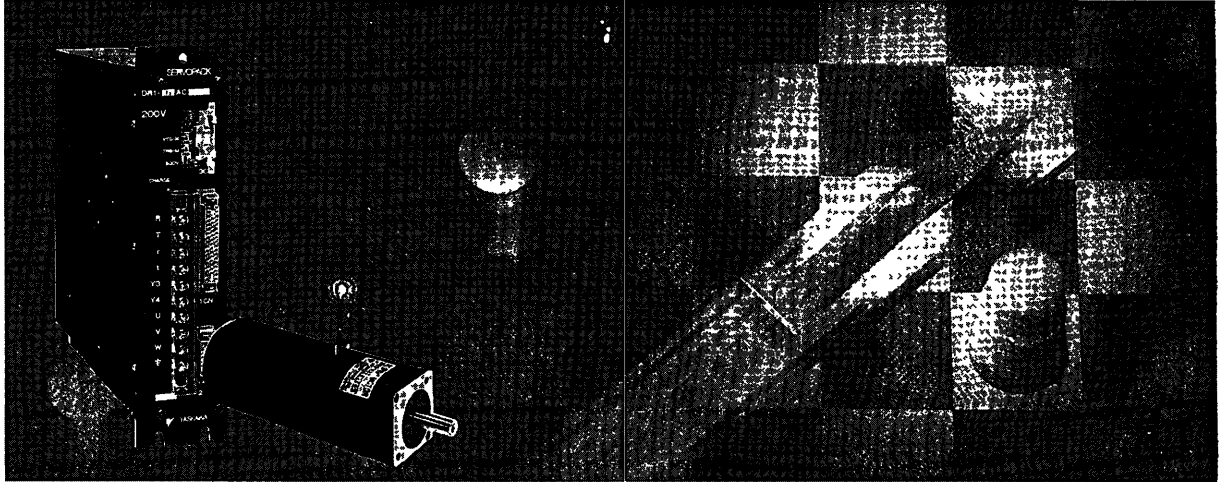

YASKAWA

Yaskawa AC Servo Drives with absolute encoder have been developed as basic mechatronics drives for the most advanced FA and FMS, including robots and machine tools. In addition, Σ series has been newly developed.

This manual covers AC servo drive Σ series for speed (torque) control. AC Servo Drives consist primarily of AC SERVOMOTORS and their controllers, SERVOPACKS. The AC SERVOMOTOR features a high power rating for achieving quick response. Custom LSI and hybrid ICs built in SERVOPACK reduce the unit size and simplify wiring. The additional feature of a highly accurate pulse resolution offers non-stop pulse flow.

For your mechatronics systems, the flexible combination of our AC SERVOMOTOR and SERVOPACK achieves stable control operation with high accuracy, quick response control under any environmental condition, and easy maintenance by display/protective functions.

FEATURES

- (1) Highest power rating and fastest response in the class
- (2) For SGM SERVOMOTORS :
1/3 the size and weight of conventional models
For DR1 SERVOPACKS :
1/4 the size of conventional models.
- (3) Both incremental and absolute encoders available in a base-mounted SERVOPACK
- (4) Easily operated with an auto tuning function
- (5) High performance with a speed control range of 1: 5000 realized
- (6) Number of wires between the motor and the encoder is reduced from 15 to 9 (with incremental encoder).
- (7) Can be installed under any environmental condition due to varnish coating.

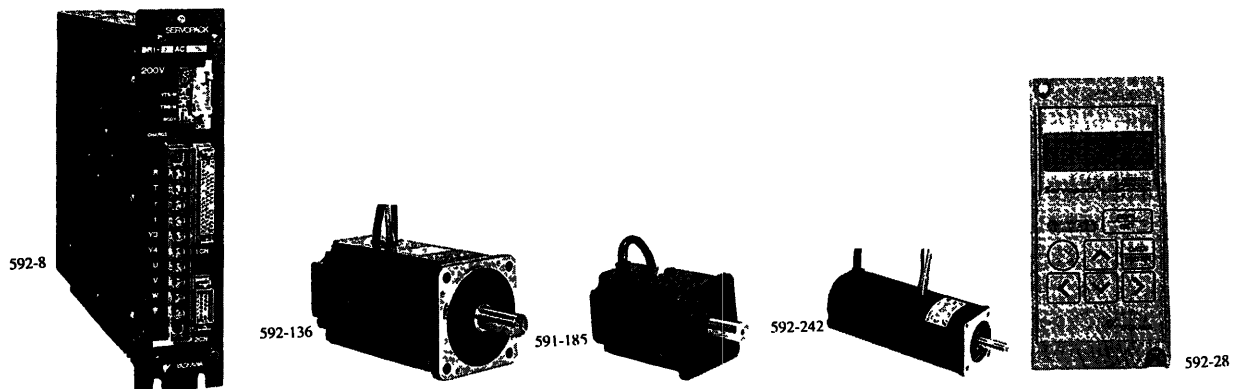

CONTENTS

	Page
1. RATINGS AND SPECIFICATIONS	1
1.1 RATINGS AND SPECIFICATIONS OF SGM SERVOMOTORS (200VAC)	1
1.1.1 Ratings and Specifications	1
1.1.2 Torque-Speed Characteristics	3
1.2 RATINGS AND SPECIFICATIONS OF SGM SERVOMOTORS (100VAC)	4
1.2.1 Ratings and Specifications	4
1.2.2 Torque-Speed Characteristics	5
1.3 RATINGS AND SPECIFICATIONS OF DR1 SERVOPACKS	6
2. TYPE DESIGNATION	8
2.1 OUTLINE OF SYSTEM	8
2.2 TYPE DESIGNATION	8
3. LIST OF STANDARD COMBINATION	10
4. CHARACTERISTICS	11
4.1 OVERLOAD CHARACTERISTICS	11
4.2 STARTING AND STOPPING TIME	12
4.3 ALLOWABLE FREQUENCY OF OPERATION	13
4.4 SERVOMOTOR FREQUENCY	15
4.5 MOTOR SPEED-REFERENCE INPUT CHARACTERISTICS	15
(Only at speed control mode)	
4.6 MOTOR MECHANICAL CHARACTERISTICS	16
4.6.1 Mechanical Strength	16
4.6.2 Allowable Radial Load and Thrust Load	16
4.6.3 Mechanical Specifications	16
4.6.4 Direction of Rotation	17
4.6.5 Impact Resistance	18
4.6.6 Vibration Resistance	18
4.6.7 Vibration Class	18
5. CONFIGURATION	19
5.1 CONNECTION DIAGRAM	19
5.2 EXTERNAL TERMINALS	20
5.3 APPLICABLE RECEPTACLES	20
5.3.1 1CN (Connector for I/O Signals)	20
5.3.2 2CN (Connector for Encoder)	20
5.4 CONNECTION (IN SPEED CONTROL OR TORQUE CONTROL MODE)	21
5.4.1 Connection Diagram	21
5.4.2 Connector 1CN for I/O Signals	23
5.5 CONNECTION (IN POSITION CONTROL MODE)	29
5.5.1 Connection Diagram	29
5.5.2 Connector 1CN for I/O Signals	30
5.6 OUTPUT CIRCUIT	34
5.6.1 Optical Encoder (PG) Output Circuit	34
5.6.2 Holding Brake Interlock Signal	36
5.7 CONNECTOR 2CN FOR OPTICAL ENCODER	37
5.7.1 Connector 2CN Layout	37
5.7.2 Cable Specifications	38
5.7.3 Connection	39

	Page
6. OPERATION	40
6.1 POWER ON AND OFF	40
6.2 SPEED REFERENCE	41
6.2.1 Speed Reference Circuit	41
6.2.2 Stop Reference Circuit	43
6.2.3 Handling of Speed Reference Input Terminal	43
6.2.4 Auxiliary Reference Circuit (± 2 to $\pm 10V$)	43
6.2.5 Speed Control with Zero Clamp	44
6.2.6 Soft Start Function	44
6.2.7 Jog Operation	44
6.2.8 Internal Setting Speed Control	44
6.3 TORQUE CONTROL MODE	45
6.3.1 Torque Control I	45
6.3.2 Torque Control II (Torque Control with Speed Limit + Speed Control)	46
6.4 POSITION CONTROL MODE	48
6.4.1 Input Reference Pulse Logical Level	48
6.4.2 Reference Pulse Form	48
6.4.3 Reference Pulse Timing	49
6.4.4 Reference Pulse (Including CLR Input) Interface	50
6.4.5 Clear Input Signal (CLR)	51
6.4.6 Position Completion Signal (\overline{COIN})	51
6.4.7 I/O Signal Timing	51
6.4.8 Number of Input Reference Pulses and Motor Rotation Amount	52
6.5 PROTECTIVE FUNCTIONS	52
6.5.1 Dynamic Brake Function	52
6.5.2 Error Detection Functions	53
6.5.3 Servo Alarm Output (ALM+, ALM-)	54
6.5.4 Protective Circuit Operation	54
6.5.5 Resetting Servo Alarm	54
6.6 DISPLAY	54
6.7 PRECAUTIONS FOR APPLICATION	55
6.7.1 Overheating Loads	55
6.7.2 Load Inertia J_L	55
6.7.3 High Voltage Line	55
6.8 PRECAUTIONS OF OPERATION	56
6.8.1 Noise Control	56
6.8.2 Power Line Protection	59
6.9 APPLICATION	60
6.9.1 Connection for Reverse Motor Running	60
6.9.2 Motor Speed Measurement and Torque Reference	60
7. USER CONSTANTS	61
8. DIGITAL OPERATOR (TYPE : JUSP-OP02A)	70
8.1 SWITCH OPERATION	70
8.2 DIGITAL OPERATOR FUNCTIONS	71
8.3 STATUS INDICATION MODE	72

	Page
8.4 SETTING MODE	73
8.4.1 User Constant (Data) Setup and Monitor (Cn-03 to Cn-21)	73
8.4.2 User Constant (Memory Switch) Setup and Monitor (Cn-01 and Cn-02)	74
8.4.3 Digital Operator Controlled Operation Mode Selection and Operating Procedure	75
8.4.4 Speed Reference Offset Adjustment	77
8.4.5 Clearing Fault Traceback Data	78
8.4.6 Check of Motor Parameters	79
8.5 MONITOR MODE	81
8.6 FAULT TRACEBACK MODE	83
9 INSTALLATION AND WIRING	85
9.1 RECEIVING	85
9.2 INSTALLATION	85
9.2.1 SGM SERVOMOTOR	85
9.2.2 DR1 SERVOPACK	86
9.3 WIRING	87
9.3.1 Rated Current and Cable Size	87
9.3.2 Wiring Precautions	88
10. OUTSIDE DIMENSIONS in mm (inches)	89
10.1 SGM SERVOMOTOR	89
10.2 DR1 SERVOPACK	96
10.3 DIGITAL OPERATOR	97
10.4 CONNECTOR KIT	97
10.5 CABLES	98
10.6 NOISE FILTER	99
10.7 PERIPHERAL DEVICES	100
11. TEST RUN	101
11.1 CHECK ITEMS BEFORE TEST RUN	101
11.1.1 SGM SERVOMOTOR	101
11.1.2 DR1 SERVOPACK	101
11.2 TEST RUN PROCEDURES	101
11.2.1 Preparation for Operation	101
11.2.2 Operation	102
11.2.3 Inspection during Test Run	102
12. ADJUSTMENT	103
12.1 CHARACTERISTICS PRESET AT THE FACTORY PRIOR TO SHIPMENT	103
12.2 RESET	104
13. INSPECTION AND MAINTENANCE	105
13.1 SGM SERVOMOTOR	105
13.2 DR1 SERVOPACK	105
14 TROUBLESHOOTING	106
14.1 SGM SERVOMOTOR	106
14.2 DR1 SERVOPACK	107
14.2.1 LED Indication (7-segment) for Troubleshooting	107
14.2.2 Examples of Troubleshooting for Defective Wiring or Parts (Table 14.3)	110
14.2.3 Examples of Errors Resulting Setting Errors (Table 14.4)	110

1. RATINGS AND SPECIFICATIONS

1.1 RATINGS AND SPECIFICATIONS OF SGM SERVOMOTORS (200VAC)

1.1.1 Ratings and Specifications

Time Rating : Continuous

Insulation : Class B

Withstand Voltage : 1500VAC

Insulation Resistance : 500VDC, 10M Ω
or more

Enclosure : Totally-enclosed, self-cooled

Ambient Temperature : 0 to +40°C

Ambient Humidity : 20 to 80%

(non-condensing)

Vibration : 15 μ m or below

Excitation : Permanent magnet

Mounting : Flange-mounted

Drive Method : Direct drive

Table 1 1 Ratings and Specifications of SGM SERVOMOTORS (200VAC)

Item	Motor Type SGM-	A3A31	A5A31	01A31	02A31	04A31	08A31
		Rated Output*	W (HP)	30 (0 04)	50 (0 07)	100 (0 13)	200 (0 27)
Rated Torque*	N m (lb in)	0 095 (0 845)	0 159 (1 41)	0 318 (2 82)	0 637 (5 63)	1 27 (11 3)	2 39 (21 1)
Instantaneous Peak Torque*	N m (lb in)	0 29 (2 53)	0 48 (4 23)	0 96 (8 46)	1 91 (16 9)	3 82 (33 9)	7 1 (63 3)
Rated Current*	A (rms)	0 42	0 6	0 87	2 0	2 6	4 4
Instantaneous Max Current*	A (rms)	1 3	1 9	2 8	6 0	8 0	13 9
Rated Speed*	r/min	3000					
Instantaneous Max Speed*	r/min	4500					
Torque Constant*	N m/A (rms) (lb in/A) (rms)	0 255 (2 24)	0 286 (2 52)	0 408 (3 59)	0 355 (3 12)	0 533 (4 69)	0 590 (5 19)
Moment of Inertia $J_M (= GD^2 M/4)$	kg m ² $\times 10^{-4}$ (lb in s ² $\times 10^{-3}$)	0 021 (0 018)	0 026 (0 023)	0 040 (0 036)	0 123 (0 109)	0 191 (0 169)	0 671 (0 595)
Power Rating*	kW/s	4 36	9 63	25 4	32 8	84 6	85 1
Rated Angular Acceleration*	rad/s ²	45200	61200	79500	51800	66600	35600
Inertia Time Constant	ms	1 5	0 9	0 5	0 4	0 3	0 3
Inductive Time Constant	ms	1 5	1 8	1 9	5 4	6 4	13

Notes

- Items marked with * and the torque-speed characteristic are measured when the armature winding combined with the DR1 SERVOPACK is 100°C. Other figures are measured when the temperature is 20°C. All the figures are typical values.
- Rated torque is the continuous allowable torque when the motor is mounted to a heat sink of 250 \times 250 \times 6 (mm) and the ambient temperature is 40°C

1.1.1 Ratings and Specifications (Cont'd)

[OPTION]

When options are applied, inertia is increased as shown in the following table.
 Characteristics may vary accordingly.

Item	Type	SGM-					
		A3A	A5A	01A	02A	04A	08A
With Holding Brake	$\text{kg} \cdot \text{m}^2 \times 10^{-1}$ $(\text{lb} \cdot \text{in} \cdot \text{s}^2 \times 10^3)$		0 0085 (C 0074)		0 058 (0 050)		0 14 (0 12)
With 12-bit ABSO	$\text{kg} \cdot \text{m}^2 \times 10^{-4}$ $(\text{lb} \cdot \text{in} \cdot \text{s}^2 \times 10^3)$				0 025 (0 021)		

1.1.2 Torque-Speed Characteristics

• TYPE SGM-A3A

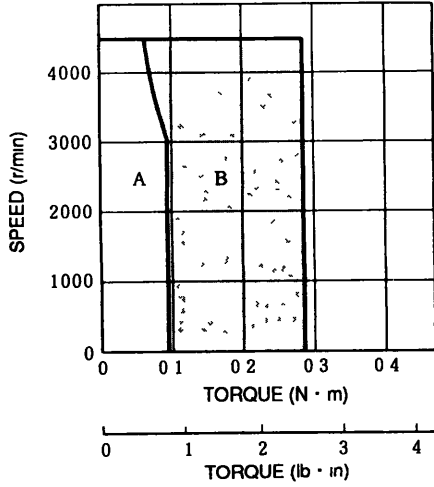

• TYPE SGM-A5A

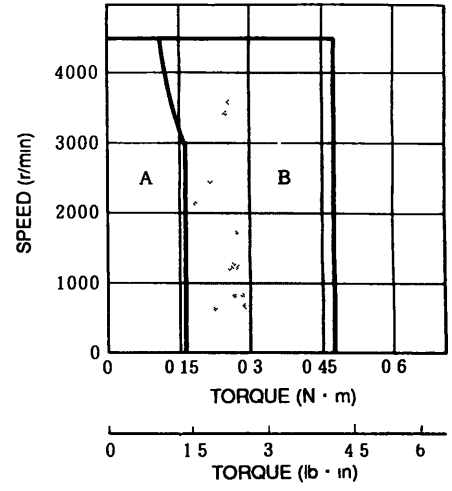

• TYPE SGM-01A

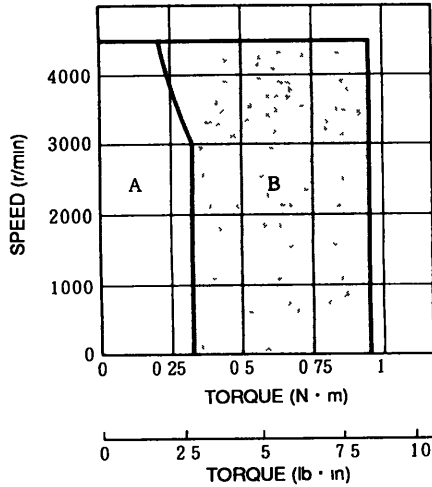

• TYPE SGM-02A

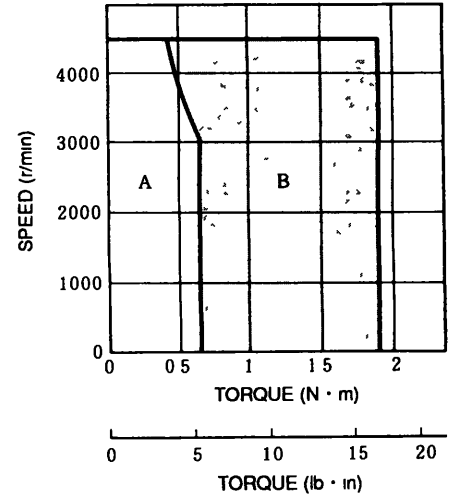

• TYPE SGM-04A

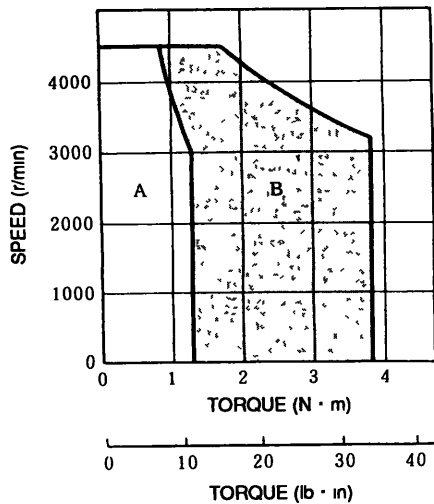

• TYPE SGM-08A

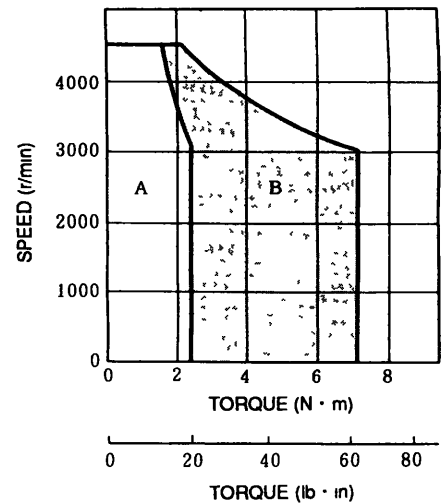

A : CONTINUOUS DUTY ZONE
B : INTERMITTENT DUTY ZONE

1.2 RATINGS AND SPECIFICATIONS OF SGM SERVOMOTORS (100VAC)

1.2.1 Ratings and Specifications

Time Rating : Continuous

Insulation : Class B

With stand Voltage : 1500VAC

Insulation Resistance : 500VDC, 10MΩ
or more

Enclosure : Totally-enclosed, self-cooled

Ambient Temperature : 0 to +40°C

Ambient Humidity : 20 to 80%
(non-condensing)

Vibration : 15µm or below

Excitation : Permanent magnet

Mounting : Flange-mounted

Drive Method : Direct drive

Table 1 2 Ratings and Specifications of SGM SERVOMOTORS (100VAC)

Item	Motor Type SGM-	A3B31	A5B31	01B31	02B31
Rated Output*	W (HP)	30 (0 04)	50 (0 07)	100 (0 13)	200 (0 27)
Rated Torque*	N m (lb in)	0 095 (0 845)	0 159 (1 41)	0 318 (2 82)	0 637 (5 63)
Instantaneous Peak Torque*	N m (lb in)	0 29 (2 53)	0 48 (4 23)	0 96 (8 46)	1 91 (16 9)
Rated Current*	A (rms)	0 63	0 9	2 2	2 7
Instantaneous Max Current*	A (rms)	2 0	2 9	7 1	8 4
Rated Speed*	r/min	3000			
Instantaneous Max Speed*	r/min	4500			
Torque Constant*	N m/A (rms) (lb in/A) (rms)	0 168 (1 47)	0 194 (1 71)	0 156 (1 37)	0 255 (2 24)
Moment of Inertia $J_M (= GD^2 M/4)$	kg m ² × 10 ⁻⁴ (lb in s ² × 10 ⁻³)	0 021 (0 018)	0 026 (0 023)	0 040 (0 036)	0 123 (0 109)
Power Rating*	kW/s	4 36	9 63	25 4	32 8
Rated Angular Acceleration*	rad/s ²	45200	61200	79500	51800
Inertia Time Constant	ms	1 6	0 9	0 6	0 4
Inductive Time Constant	ms	1 3	1 6	1 6	5 7

Notes

- 1 Items marked with * and the torque-speed characteristic are measured when the armature winding combined with the DR1 SERVOPACK is 100°C Other figures are measured when the temperature is 20°C All the figures are typical values
- 2 Rated torque is the continuous allowable torque when the motor is mounted to a heat sink of 250 × 250 × 6 (mm) and the ambient temperature is 40°C

[OPTION]

When options are applied, inertia is increased as shown in the following table.
 Characteristics may vary accordingly.

Item	Type	SGM-			
		A3B	A5B	01B	02B
With Holding Brake	$\text{kg m}^2 \times 10^4$ ($\text{lb in s}^2 \times 10^3$)		0 0085 (0 0074)		0 058 (0 050)
With 12-bit ABSO	$\text{kg m}^2 \times 10^4$ ($\text{lb in s}^2 \times 10^3$)			0 025 (0 021)	

1.2.2 Torque-Speed Characteristics

• TYPE SGM-A3B

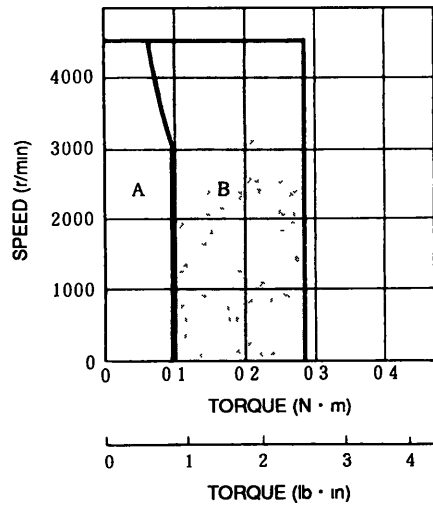

• TYPE SGM-A5B

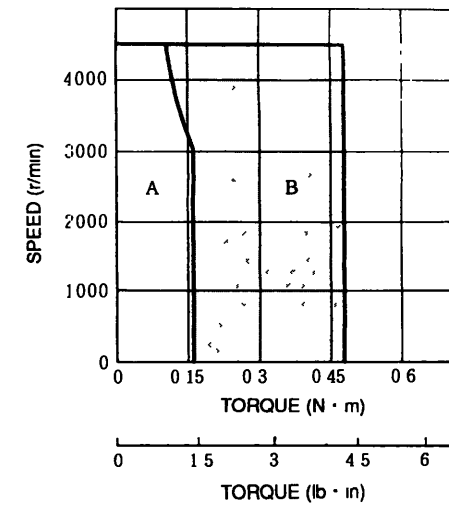

• TYPE SGM-01B

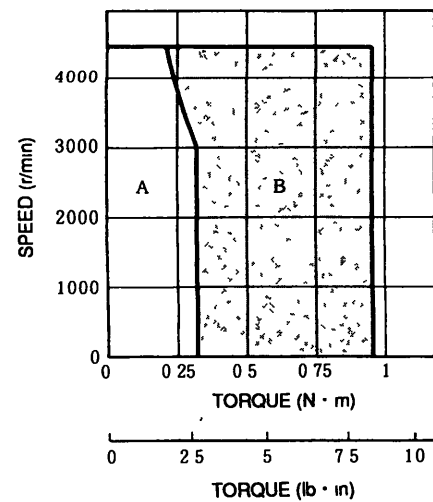

• TYPE SGM-02B

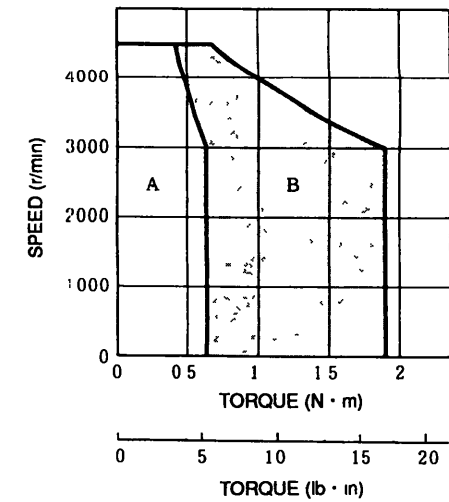

A : CONTINUOUS DUTY ZONE

B : INTERMITTENT DUTY ZONE

1.3 RATINGS AND SPECIFICATIONS OF DR1 SERVOPACKS

Table 1 3 Ratings and Specifications of DR1 SERVOPACKS

Applied Voltage		200VAC						100VAC				
SERVOPACK Type	DR1-	A3AC	A5AC	01AC	02AC	04AC	08AC	A3BC	A5BC	01BC	02BC	
Max Motor Capacity	W (HP)	30 (0 04)	50 (0 07)	100 (0 13)	200 (0 27)	400 (0 53)	750 (1 01)	30 (0 04)	50 (0 07)	100 (0 13)	200 (0 27)	
Applicable SERVOMOTORS	Type	SGM-	A3A3	A5A3	01A3	02A3	04A3	08A3	A3B3	A5B3	01B3	02B3
	Motor Capacity	W	30	50	100	200	400	750	30	50	100	200
	Rated/Max Rotation Speed		3000/4500r/min						3000/4500r/min			
	Applicable Encoder		Incremental encoder 2048P/R ^{*1}									
	Allowable Load Inertia ^{*2}	$\text{kg} \cdot \text{m}^2 \times 10^{-4}$ J_L (lb in $\text{s}^2 \times 10^{-3}$)	0 63 (0 55)	0 78 (0 69)	1 20 (1 06)	3 69 (3 26)	5 73 (4 99)	20 1 (17 5)	0 63 (0 55)	0 78 (0 69)	1 20 (1 06)	3 69 (3 26)
	Continuous Output Current	A (rms)	0 42	0 60	0 87	2 0	2 6	4 4	0 63	0 90	2 2	2 7
Max Output Current A	A (rms)	1 3	1 9	2 8	6 0	8 0	13 9	2 0	2 9	7 1	8 4	
Basic Specifications	Power Supply	Main Circuit	Single-phase 200 to 230VAC, +10 to -15%, ^{*3}					Single-phase 100 to 115VAC, ^{*3}				
		Control Circuit	50/60 Hz					+10 to -15%, 50/60 Hz				
	Control Method		Single-Phase full-wave rectifier IGBT-PWM (Sine-wave drive)									
	Feedback Pulse		Incremental encoder 2048P/R									
	Location	Ambient Temp	0 to 55°C ^{*4}									
		Storage Temp	-20 to 85°C									
Ambient and Storage Humidity		90% or less (non-condensing)										
Vibration/Shock Resistance		0 5/2G										
Structure		Rack-mounted										
Approx Mass	kg (lb)	2 7(6 0)				3 4(7 5)		2 7(6 0)		3 4(7 5)		
Speed Control ^{*5}	Speed Control Range ^{*6}	1 5000										
	Speed Regulation ^{*7}	Load	0 to 100% 0 01% or less (at rated r/min)									
		Voltage	0%									
		Temperature	25±25°C ±0 1% or less (at rated r/min)									
	Frequency Characteristics		100Hz (at $J_L=J_M$)									
	Torque Control Repeatability		±2 0%									
Accel/Decel Time Setting		0 to 10s										
Input Signal	Speed Reference	Rated Reference Voltage	Speed control mode		±6VDC (forward run at plus reference) at rated r/min							
			Torque control mode		±3VDC (forward run at plus reference) at rated torque							
		Input Impedance	Approx 30kΩ									
	Torque Reference	Rated Reference Voltage	±2 to ±10VDC (forward run at plus reference) at rated r/min									
		Input Impedance	Approx 30kΩ									
		Circuit Time Constant	Approx 47μs									
Position control Mode	Performance	Bias Setting	0 to 450r/min (setting resolution 1r/min)									
		Feed Forward Compensation	0 to 100% (setting resolution 1%)									
		Positioning Completion Width Setting	1 to 100 pulses (setting resolution 1 pulse)									
	Input Signal Reference Pulse	Input Type	Sign + pulse train (SIGN + PULS signal), 90° phase difference 2-phase pulse(phase A + B), CW Pulses + CCW pulses									
Input Pulse Form		Line driver (+5V level), open collector ^{*9}										
Input Pulse Frequency		0 to 450kpps										
	Control Signal	Clear signal (Input pulse form is the same as that of reference pulse)										
I/O Signals	Position Output	Output Form	A-, B-, C- phase line driver or C-phase open collector									
		Freq Dividing Ratio	(16 to N)/N, N = 2048 ^{*6}									
	Sequence Input		Servo ON, P drive (or torque control, zero-clamp drive), forward overtravel (P-OT), reverse overtravel (N-OT), alarm reset, forward current limit (or 1st to 3rd), reverse current limit (or 1st to 3rd)									
Sequence Output		Current limit detection ^{*10} (or positioning completion), $\overline{\text{TGON}}$, servo ready, servo alarm, alarm code (3 bits)										

Table 1 3 Ratings and Specifications of DR1 SERVOPACKS (Cont'd)

Applied Voltage	200VAC							100VAC				
SERVOPACK Type	DR1-	A3AC	A5AC	01AC	02AC	04AC	08AC	A3BC	A5BC	01BC	02BC	
Max Motor Capacity	W (HP)	30 (0 04)	50 (0 07)	100 (0 13)	200 (0 27)	400 (0 53)	750 (1 01)	30 (0 04)	50 (0 07)	100 (0 13)	200 (0 27)	
Dynamic Brake	Operated at main power OFF, servo alarm, servo OFF overtravel											
Regenerative Unit	Not provided			Built-in				Not provided		Built-in		
Overtravel	DB Stop, deceleration stop or coasting to a stop											
Protective Function	Overcurrent, fuse blown, regenerative error, PG disconnection, overload, overvoltage, overspeed, underspeed, A/D error, overrun prevention, origin error, CPU error, parameter error, overflow detection											
Indication	7-segment LEDs (alarm and status display), power (CHARGE) LED											
Monitor Output	Speed Control Mode				Speed 0 5V/1000r/min				Torque 0 5V/100%			
	Position Control Mode (Monitor Selection)				Speed 0 5V/1000r/min (Lag pulse 1 5V/50 pulses)				Torque 0 5V/100% (Reference speed 0 5V/1000r/min)			
Others	Torque control, zero-clamp drive, soft start/stop, brake interlock signal output, reverse run connection, JOG run											

*1 For further information on products with absolute encoder, refer to separate bulletin, TS-S800-1 4

*2 When load J_L exceeds applicable range, refer to Par 6 7.2 "Load Inertia"

*3 Supply voltage should not exceed 230V+10% (253V) or 115V+10% (127V). If the voltage should exceed these values, a step-down transformer is required

*4 When housed in a panel, the internal temperature must not exceed ambient temperature range

*5 Control functions can be changed by setting user constant

*6 In the speed control range, the lowest speed is defined as the condition in which there is 100% load variation, but not stopped

*7 Speed regulation is generally defined as follows

$$\text{Speed regulation} = \frac{\text{No load speed} - \text{Full load speed}}{\text{Rated speed}} \times 100 (\%)$$

Motor speed may be changed by voltage variation or operational amplifier drift due to temperature. The ratio of this speed change to the rated speed represents the speed regulation due to voltage or temperature change

*8 Used for application at rated reference voltage other than ±6V

*9 Current limit detection . in speed control mode

Positioning completion . in position control mode

2. TYPE DESIGNATION

2.1 OUTLINE OF SYSTEM

- DR1 SERVOPACK

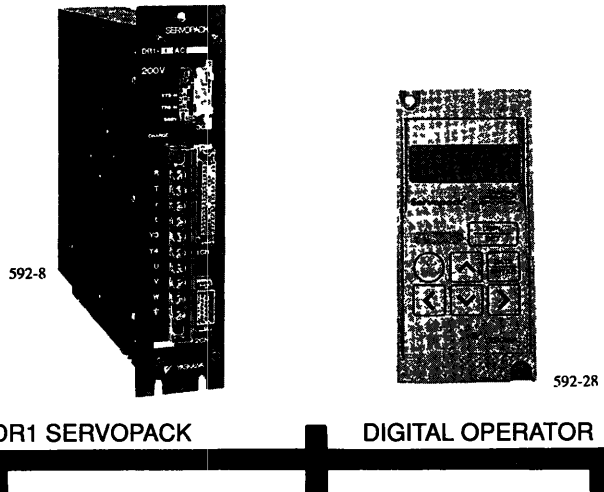

- SGM SERVOMOTOR

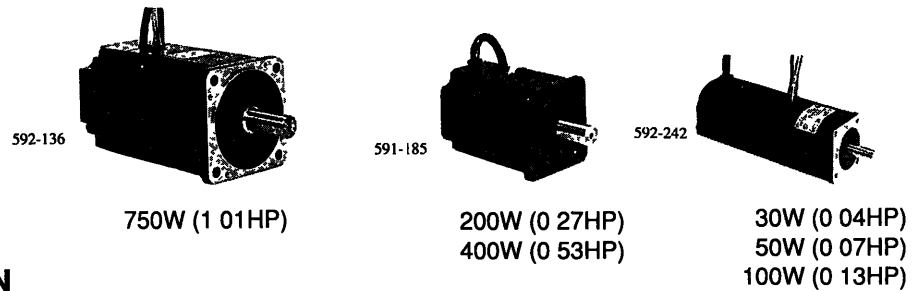

2.2 TYPE DESIGNATION

(1) SGM SERVOMOTOR

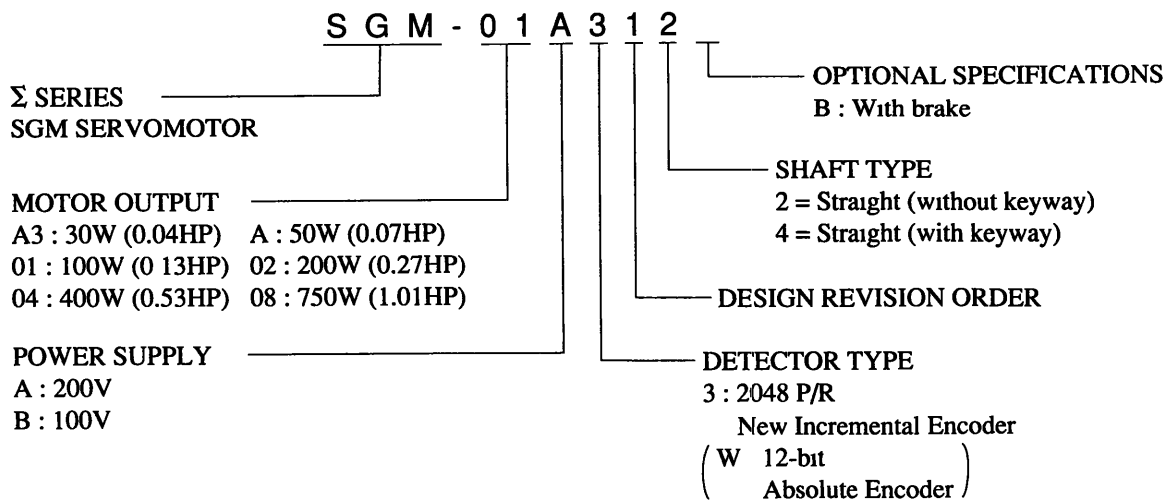

(2) DR1 SERVOPACK

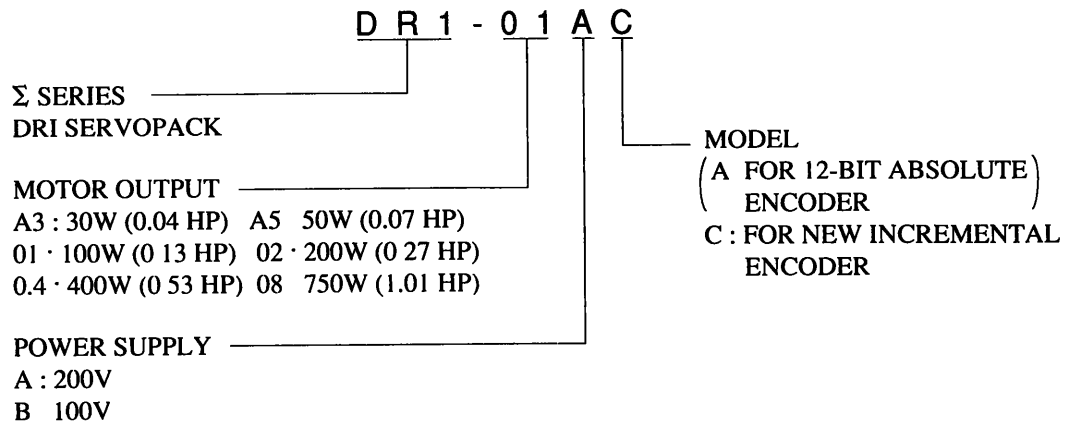

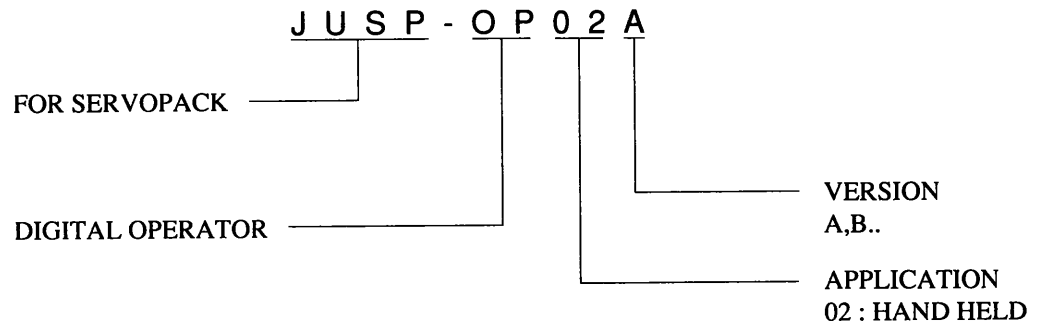

(3) DIGITAL OPERATOR



3. LIST OF STANDARD COMBINATION

Table 3 1 Combination of SGM SERVOMOTOR, DR1 SERVOPACK and Accessories

CLASS	SERVOPACK Type DR1-		SERVOMOTOR Type SGM-	Power Capacity per SERVOPACK*1 kVA	Current Capacity per MCCB or Fuse*2 A	Applicable Noise Filter	Recommended*3 Noise Filter		Power ON/OFF Switch
	Type	Specifica- tion							
200 VAC	30 W (0.04 HP)	A3AC	A3A3	0.25	5	(Good) 	LF-205A	Single- phase 200 VAC Class 5 A	YASKAWA Type HI-15E5 (35 A) or equiv- alent
	50 W (0.07 HP)	A5AC	A5A3	0.3					
	100 W (0.13 HP)	01AC	01A3	0.5					
	200 W (0.27 HP)	02AC	02A3	0.75					
	400 W (0.53 HP)	04AC	04A3	1.2	9		LF-210	Single- phase 200 VAC Class 10 A	
	750 W (1.01 HP)	08AC	08A3	2.2	16		(Poor)*4 	LF-220	
100 VAC	30 W (0.04 HP)	A3BC	A3B3	0.25	5		LF-205A	Single- phase 200 VAC Class 5 A	
	50 W (0.07 HP)	A5BC	A5B3	0.3					
	100 W (0.13 HP)	01BC	01B3	0.5					
	200 W (0.27 HP)	02BC	02B3	0.75	8		LF-210	Single- phase 200 VAC Class 10 A	

*1 Values at rated load

*2 . Operating characteristics (25°C) 200% 2s or more, 700% 0.01s or more

*3 · Made by Tokin Corp

*4 · When this type of noise filter is used, pay attention to leak current

Leak current of the recommended noise filter is 1mA or less

Leak current of the DR1 type is 8 to 15mA (rms) at starting and stopping

Specify the high-speed type for installation of a leakage breaker

(Time-delay type is not acceptable)

4. CHARACTERISTICS

4.1 OVERLOAD CHARACTERISTICS

The overload protective circuit built in DR1 SERVOPACK prevents the SGM SERVOMOTOR and DR1 SERVOPACK from overloading and restricts the allowable conduction time of DR1 SERVOPACK (See Fig.4.1). The overload detection level is set precisely by the hot start conditions at an ambient temperature of 55°C and cannot be changed.

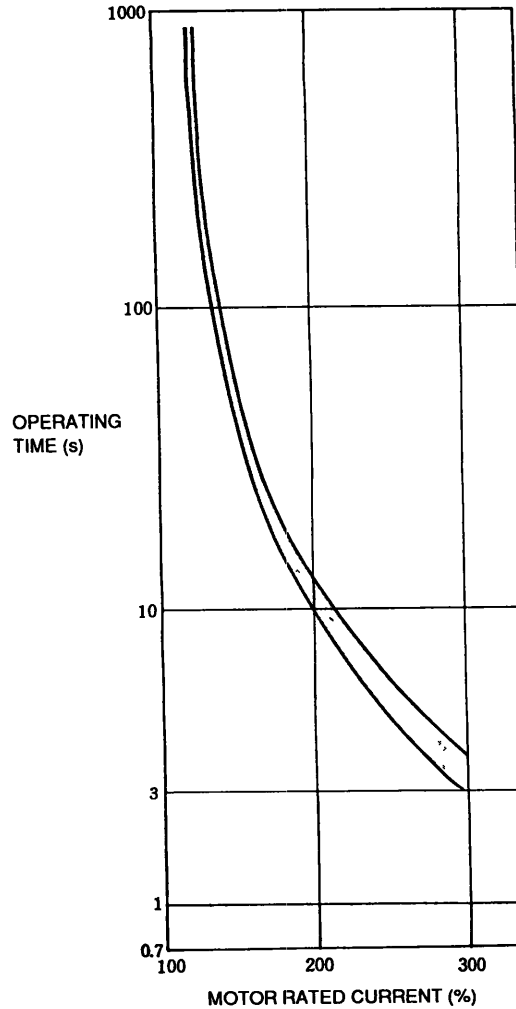

Fig 4 1 Allowable Conduction Current of SERVOPACK

4.2 STARTING AND STOPPING TIME

The starting time and stopping time of SERVOMOTOR under a constant load is shown by the formula below. Viscous or friction torque of the motor is disregarded.

Starting Time:

$$tr = 104.7 \times \frac{N_R (J_M + J_L)}{K_t \cdot I_R (\alpha - \beta)} \text{ (ms)}$$

Stopping Time:

$$tf = 104.7 \times \frac{N_R (J_M + J_L)}{K_t \cdot I_R (\alpha + \beta)} \text{ (ms)}$$

Where,

N_R : Rated motor speed (r/min)

J_M (= $GD_M^2/4$) : Moment of rotor inertia ($\text{kg} \cdot \text{m}^2 = \text{lb} \cdot \text{in} \cdot \text{s}^2$)

J_L (= $GD_L^2/4$) : Moment of load inertia ($\text{kg} \cdot \text{m}^2 = \text{lb} \cdot \text{in} \cdot \text{s}^2$)

K_t : Torque constant of motor ($\text{N} \cdot \text{m}/\text{A} = \text{lb} \cdot \text{in}/\text{A}$)

I_R : Motor rated current (A)

$\alpha = I_P/I_R$: Accel/decel current constant

I_P : Accel/decel current

(Accel/decel current α times the motor rated current) (A)

$\beta = I_L/I_R$: Load current constant

I_L : Current equivalent to load torque

(Load current β times the motor rated current) (A)

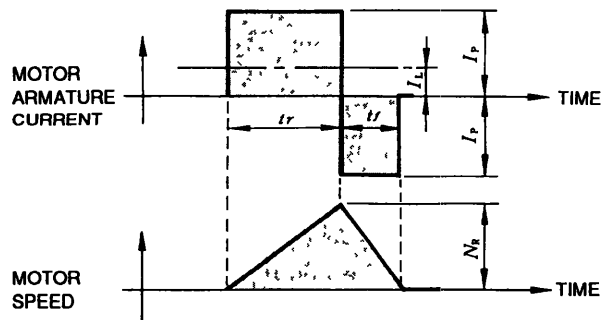

Fig 4 2 Timing Chart of Motor Armature Current and Speed (Constant Load)

4.3 ALLOWABLE FREQUENCY OF OPERATION

The allowable frequency of operation is restricted by the SERVOPACK and SERVOMOTOR, and both the conditions must be considered for satisfactory operation.

(1) Allowable Frequency of Operation Restricted by the SERVOPACK

The allowable frequency of operation is restricted by the heat generated in the regenerative resistor in the Servopack, and varies depending on the motor types, capacity, load J_L , acceleration/deceleration current values, and motor speed. If the frequency of operation exceeds 60 times/min when load $J_L = 0$

before the rated speed is reached, or if it exceeds $\frac{60}{m+1}$ cycles/min when $J_L = J_M \times m$, contact your Yaskawa representative.

(2) Allowable Frequency of Operation Restricted by the SERVOMOTOR

The allowable frequency of operation varies depending on the load conditions, motor running time and the operating conditions. Typical examples are shown below. See Par. 4.2, "STARTING AND STOPPING TIME" for symbols.

- When the motor repeats rated speed operation and being at standstill (Fig. 4.3).

Cycle time (T) should be determined so that RMS value of motor armature current is lower than the motor rated current:

$$T \geq \frac{I_p^2 (tr + tf) + I_L^2 ts}{I_R^2} \text{ (s)}$$

Where cycle time (T) is determined, values I_p , tr , tf satisfying the formula above, should be specified.

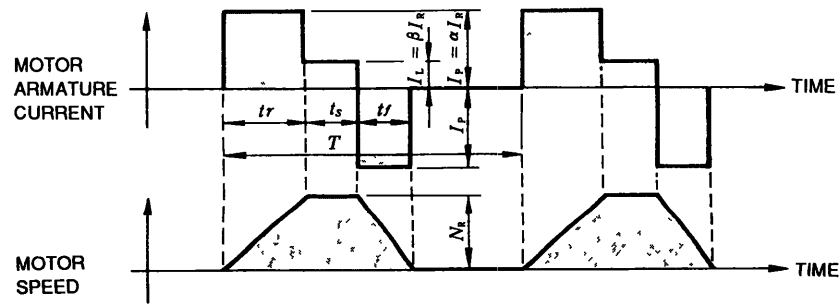

Fig 4 3 Timing Chart of Motor Armature Current and Speed
(Restricted by SERVOMOTOR)

4.3 ALLOWABLE FREQUENCY OF OPERATION (Cont'd)

- When the motor remains at standstill between cycles of acceleration and deceleration without continuous rated speed running (Fig.4.4).

The timing chart of the motor armature current and speed is as shown in Fig.4.4.

The allowable frequency of operation “n” can be calculated as follows:

$$n = 286.5 \times \frac{Kt \cdot I_R}{N_R(J_M + J_L)} \times \left(\frac{1}{\alpha} - \frac{\beta^2}{\alpha^3} \right) \text{ (times/min)}$$

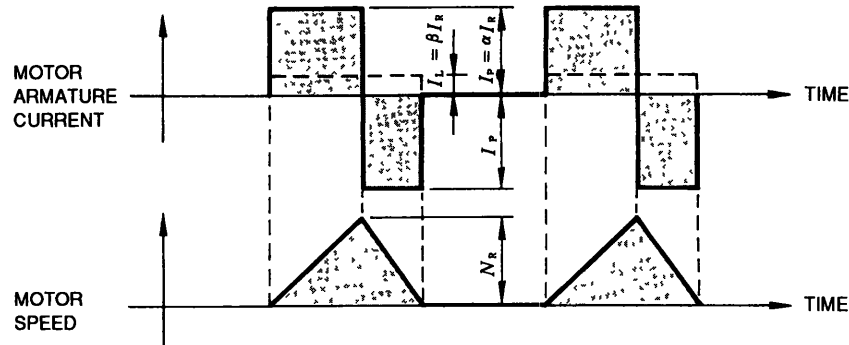

Fig 4 4 Timing Chart of Motor Armature Current and Speed
(The motor remains at standstill between cycles of accel/decel without continuous rated speed running)

- When the motor accelerates, runs at constant speed, and decelerates in a continuing cycle without being at standstill (Fig.4.5).

The timing chart of the motor armature current and speed is as shown in Fig.4.5.

The allowable frequency of operation “n” can be calculated as follows:

$$n = 286.5 \times \frac{Kt \cdot I_R}{N_R(J_M + J_L)} \times \left(\frac{1}{\alpha} - \frac{\beta^2}{\alpha} \right) \text{ (times/min)}$$

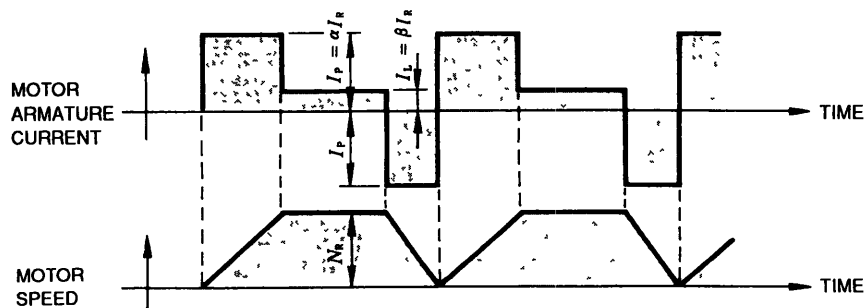

Fig. 4 5 Timing Chart of Motor Armature Current and Speed
(The motor accelerates, runs at constant speed, and decelerates in a continuing cycle without being at standstill)

4.4 SERVOMOTOR FREQUENCY

In the servo drive consisting of SERVOPACK and SERVOMOTOR, motor speed amplitude is restricted by the maximum armature current controlled by SERVOPACK.

The relation between motor speed amplitude (N) and frequency (f) is shown by the formula below :

$$N = 1.52 \times \frac{\alpha \cdot Kt \cdot I_R}{(J_M + J_L) f} \quad (\text{r/min})$$

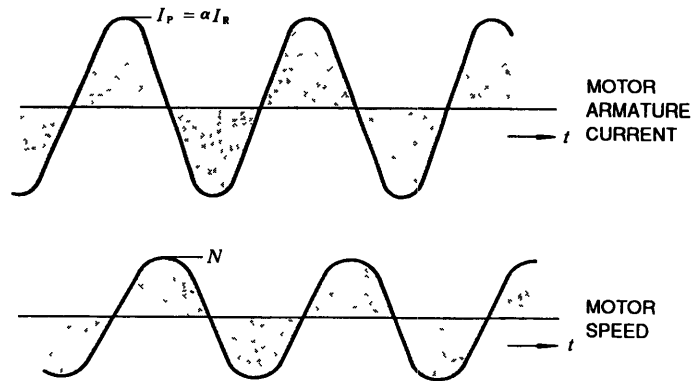

Fig 4 6 Timing Chart of Motor Armature Current and Speed
(Restricted by the maximum armature current)

4.5 MOTOR SPEED-REFERENCE INPUT CHARACTERISTICS (Only at speed control mode)

Fig. 4.7 shows motor speed and input voltage curve when speed reference input terminals 1CN-⑤ and -⑥ are used. Reference input voltage for rated rotation speed (3000 r/min) can be set by adjusting SERVOPACK user constant Cn-03. For user constant, see Par. 7, “USER CONSTANTS,”

The forward motor rotation (+) means counterclockwise (CCW) rotation when viewed from the drive end.

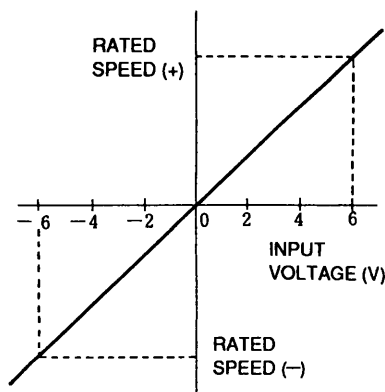

Fig 4 7 Speed-input Voltage Characteristics

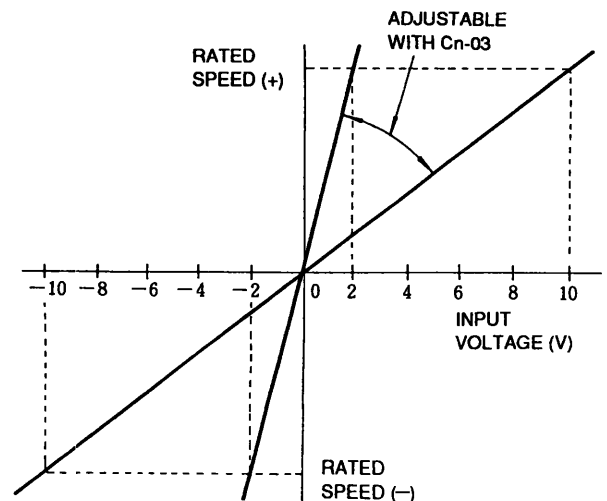

Fig 4 8 Speed-input Voltage Characteristics when User Constant Cn-03 is Adjusted

4.6 MOTOR MECHANICAL CHARACTERISTICS

4.6.1 Mechanical Strength

SGM SERVOMOTORS can carry up to 300% of the rated momentary maximum torque at output shaft.

4.6.2 Allowable Radial Load and Thrust Load

Table 4.1 shows allowable loads according to SGM SERVOMOTOR types.

Table 4 1 Allowable Radial Load and Thrust Load

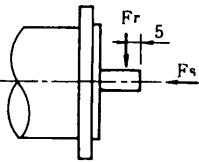
SERVOMOTOR Type	Allowable Radial Load Fr [N (lb)]	Allowable Thrust Load Fs [N (lb)]	Reference Diagram
SGM-A3	49 (11)	19 (4)	
SGM-A5	68 (15)	19 (4)	
SGM-01	68 (15)	19 (4)	
SGM-02	196 (44)	49 (11)	
SGM-04	196 (44)	68 (15)	
SGM-08	343 (77)	98 (22)	

Note Load generated from motor torque plus load applied to the shaft extension never exceed the values mentioned above

4.6.3 Mechanical Specifications

Table 4 2 Mechanical Specifications in mm (inches)

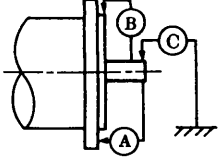
Accuracy (T I R)		Reference Diagram
Flange Surface Perpendicular to Shaft Ⓐ	0.04 (0.0016)	
Flange Diameter Concentric to Shaft Ⓑ	0.04 (0.0016)	
Shaft Run Out Ⓒ	0.02 (0.00079)	

Note . T.I.R (Total Indicator Reading)

4.6.4 Direction of Rotation

SGM SERVOMOTORS rotate counterclockwise (CCW) when viewed from the drive end. For reversing the forward rotating direction, see Par. 6.9.1 or Table 7.3.

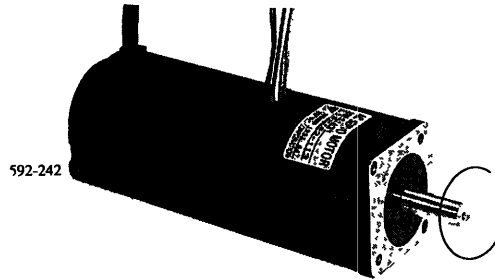
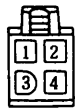

Fig. 4 9 AC SERVOMOTOR

(1) Connector Specifications

- Motor connection
(for standard SERVOMOTOR)



1	Phase-U	Red
2	Phase-V	White
3	Phase-W	Blue
4	FG (Frame ground)	Green

- Motor connection
(for SERVOMOTOR with brake)

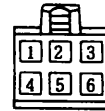

1	Phase-U	Red
2	Phase-V	White
3	Phase-W	Blue
4	FG (Frame ground)	Green
5	Brake terminal	Black
6	Brake terminal	Black

- Detector connection
(incremental encoder)

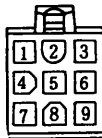

1	Channel A output	Blue
2	Channel \bar{A} output	Blue/Black
3	Channel B output	Yellow
4	Channel \bar{B} output	Yellow/Black
5	Channel C output	Green
6	Channel \bar{C} output	Green/Black
7	0 V (Power supply)	Gray
8	+5 V (Power supply)	Red
9	FG (Frame ground)	Orange

4.6.5 Impact Resistance

When mounted horizontally and exposed to vertical shock impulses, the motor can withstand up to two impacts with impact acceleration of 10G (Fig. 4.10).

NOTE

A precision detector is mounted on the opposite-drive end of the SGM SERVOMOTOR. Care should be taken to protect the shaft from impacts that could damage the detector.

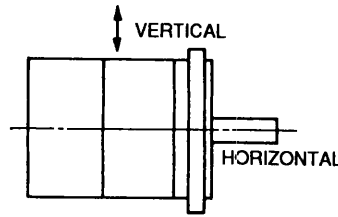

Fig 4 10 Impact Resistance

4.6.6 Vibration Resistance

When mounted horizontally, the motor can withstand vibration (vertical, lateral, axial) of 2.5G (Fig. 4.11).

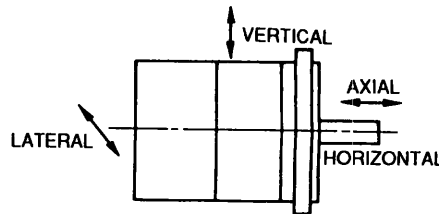

Fig 4 11 Vibration Resistance

4.6.7 Vibration Class

Vibration of the motor running at rated speed is 15 μ m or below (Fig. 4.12).

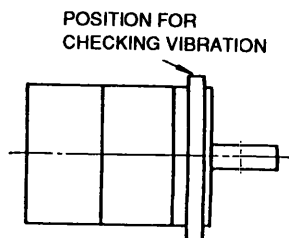

Fig 4 12 Vibration Checking

5. CONFIGURATION

5.1 CONNECTION DIAGRAM

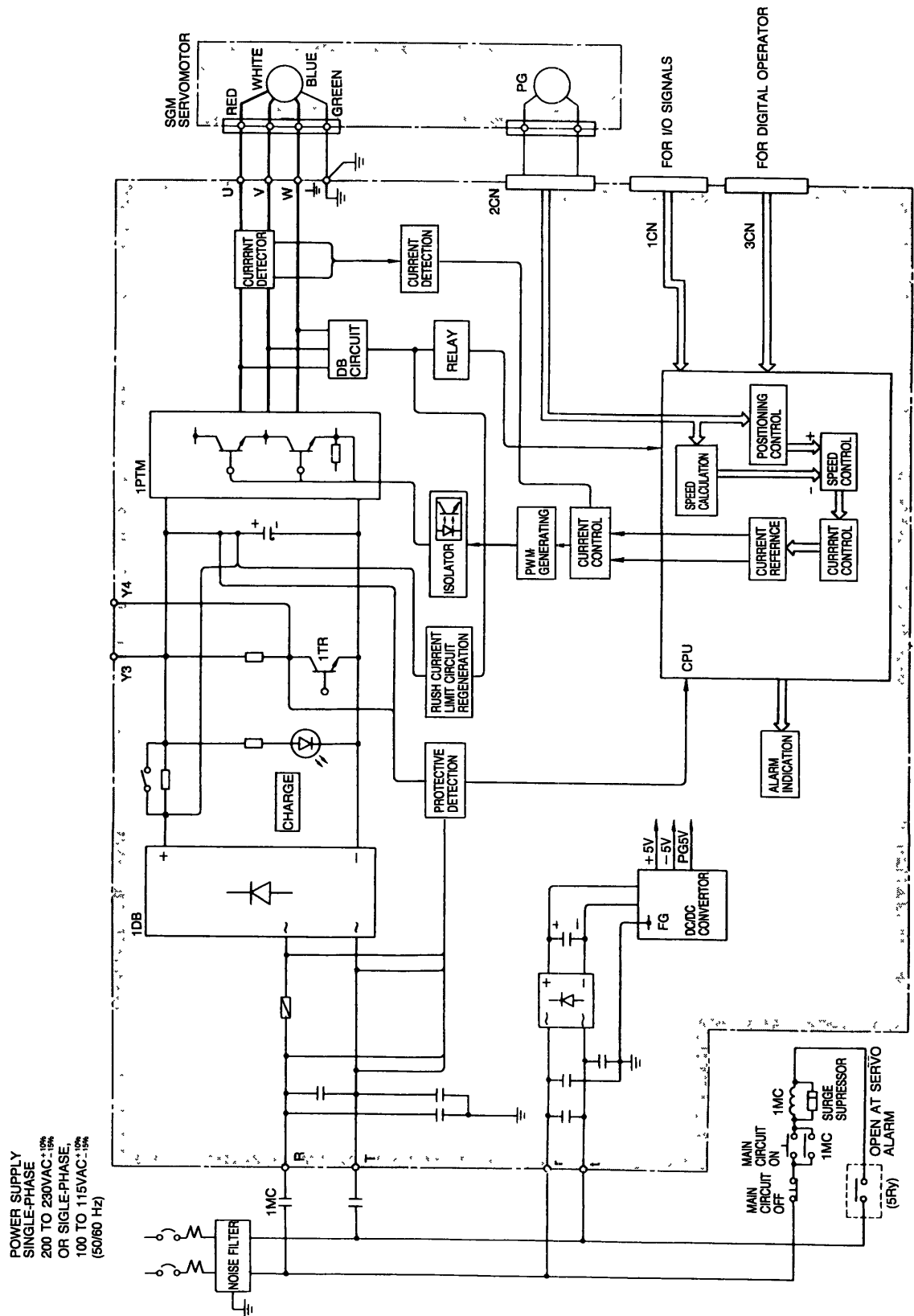

Fig 5 1 Connection Diagram of DR1 SERVOPACK (DR1 Series)

5.2 EXTERNAL TERMINALS

Table 5 1 External Terminals for SERVOPACK

Terminal Symbol	Name	Description
Ⓡ Ⓣ	Main circuit AC input	Single-phase 200 to 230 VAC $\begin{matrix} +10 \\ -15 \end{matrix}$ %, 50/60Hz *
Ⓤ Ⓥ Ⓦ	Motor connection	Connects terminal Ⓤ to motor terminal (Red) Ⓥ to (White) and Ⓦ to (Blue)
Ⓡ Ⓣ	Control power input	Single-phase 200 to 230 VAC $\begin{matrix} +10 \\ -15 \end{matrix}$ %, 50/60Hz *
Ⓧ	Ground	Connects to motor terminal (Green) Must be securely grounded
Ⓨ ₃ Ⓨ ₄	Regenerative resistor	Regenerative resistor connection terminal (External connection not normally required)

* For 100 VAC class, single-phase 100 to 115 VAC $\begin{matrix} +10 \\ -15 \end{matrix}$ %, 50/60 Hz is applied

5.3 APPLICABLE RECEPTACLES

5.3.1 1CN (Connector for I/O Signals)

Table 5 2 Specifications of Applicable Receptacles for DR1 SERVOPACK I/O Signals

Connector Type used in DR1 SERVOPACK	Applicable Receptacle Type		
	Soldering Type	Caulking Type	Case
MR-50 RFA Right Angle 50P	MR-50M*	MRP-50M01	MR-50L*

* Attached to SERVOPACK when shipping

5.3.2 2CN (Connector for Encoder)

Table 5 3 Specifications of Applicable Receptacles and Cables

Connector Type used in DR1 SERVOPACK	Applicable Receptacle Type			Cable Specifications
	Soldering Type	Caulking Type	Case	
MR-20 RMA Right Angle 20P	10120-3000VE MR-20F*	MRP-20F01	MR-20L*	B9400064

* Attached to SERVOPACK when shipping.
The cables mentioned above are provided by Yaskawa
For details, see Par 10 5, "CABLES "

5.4 CONNECTION (IN SPEED CONTROL OR TORQUE CONTROL MODE)

5.4.1 Connection Diagram

(1) Typical connection for speed control (Incremental encoder type DR1- C)

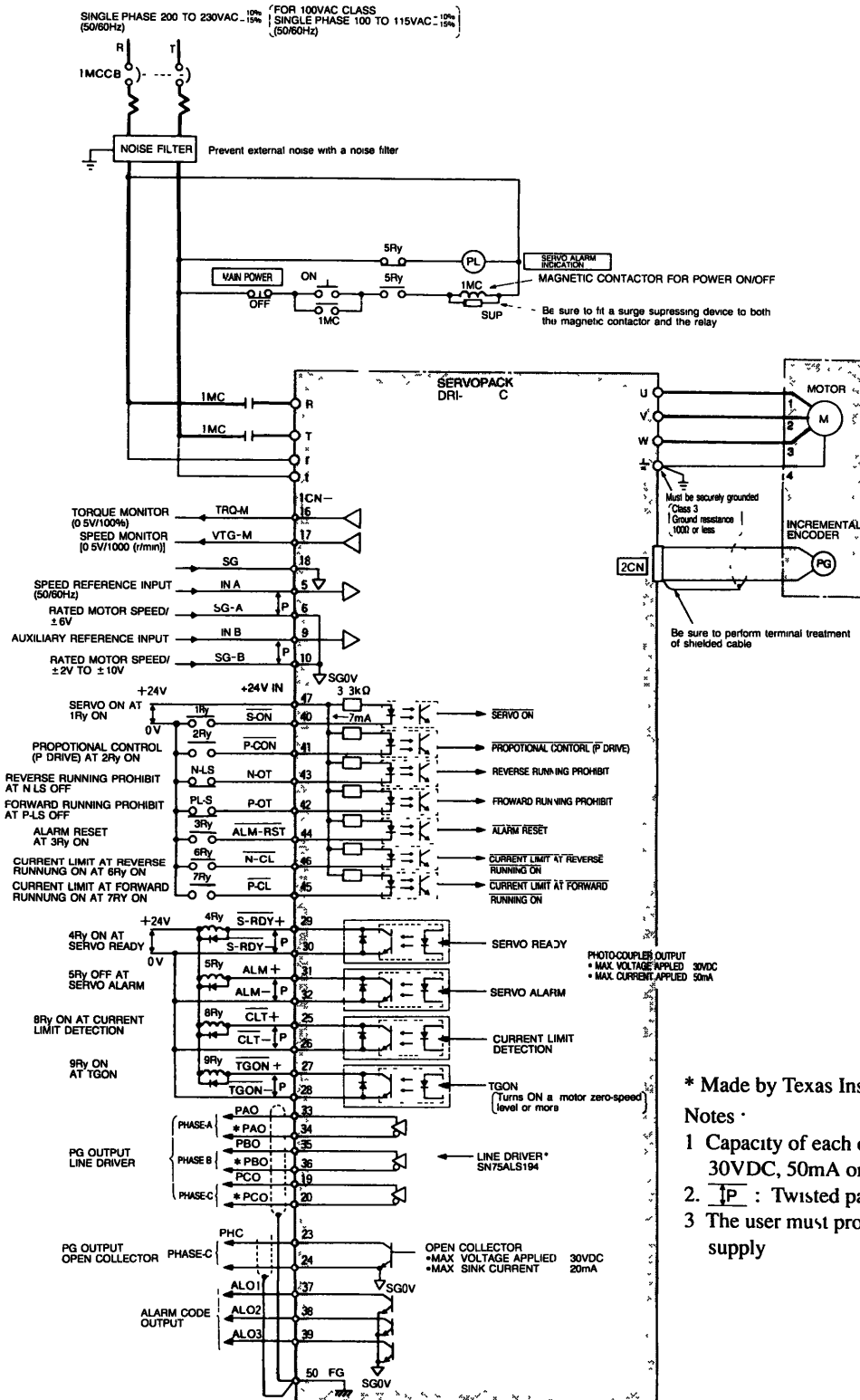

Fig 5 2 Example of Connection Diagram of DR1 SERVOPACK with a SERVOMOTOR and Peripherals (1)

(2) Typical connection for torque control (Incremental encoder type DR1- C)

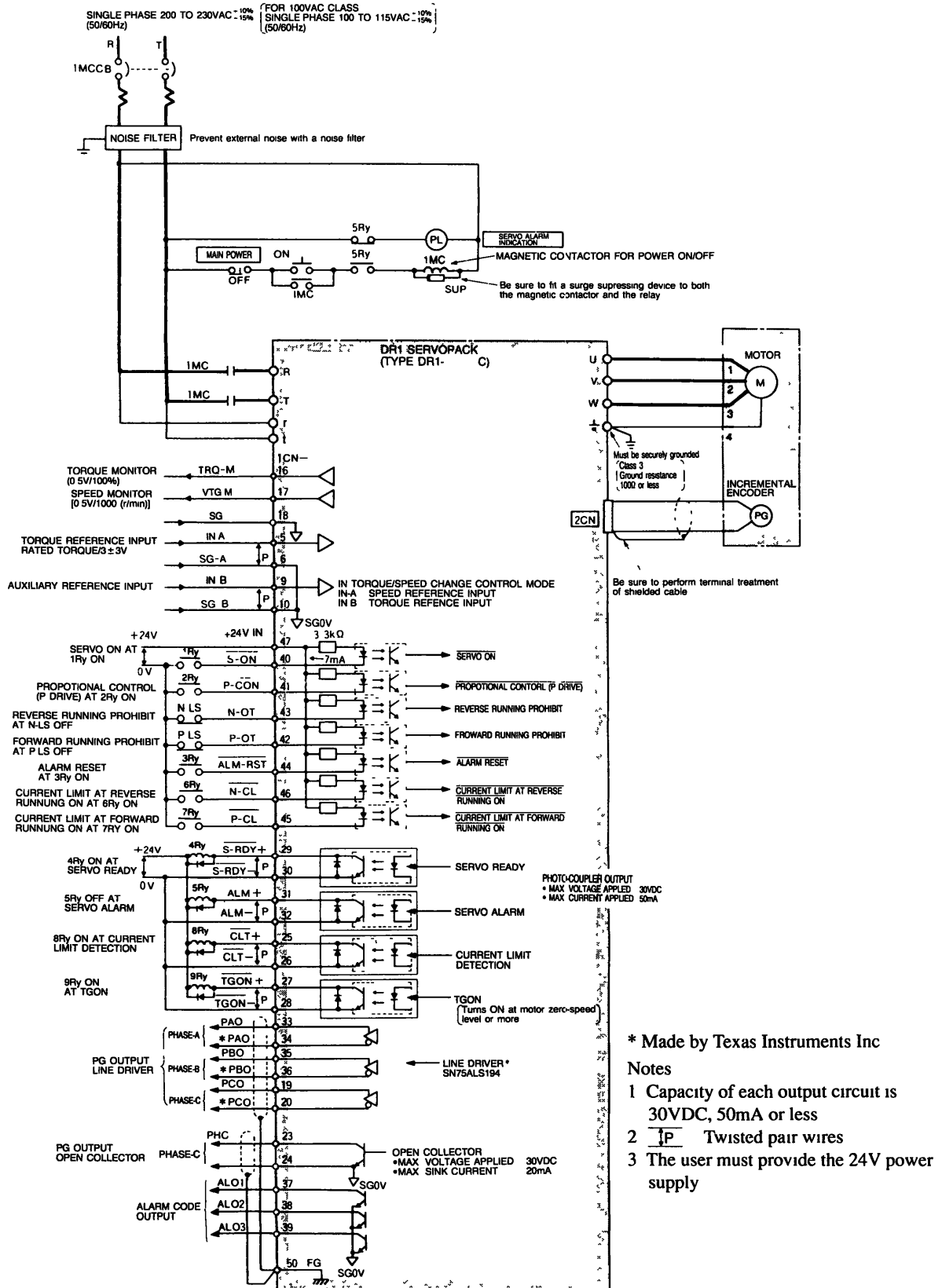

Fig 5.3 Example of Connection Diagram of DR1 SERVOPACK with a SERVOMOTOR and Peripherals (2)

5.4.2 Connector 1CN for I/O Signals

(1) Connector 1CN Layout

Table 5 4 Connector 1CN Layout of DR1 SERVOPACK

1	2	3	4	5	6	7	8	9	10	11	12	13	14	15	16	17	18
SG	SG	SG	/	IN-A	SG-A	/	/	IN-B	SG-B	/	/	SG	/	/	TRQ-M	VTG-M	SG
GND			OPEN	Speed Reference (or Torque reference) Input		OPEN		Auxiliary Input		OPEN		GND	OPEN		Speed Monitor Torque Monitor		
			19	20	21	22	23	24	25	26	27	28	29	30	31	32	
			PCO	*PCO	/	/	PHC	SG	CTL +	CLT -	TGON +	TGON -	S-RDY +	S-RDY -	ALM +	ALM -	
			Line Driver Output C ϕ		OPEN		Open Collector Output C ϕ	GND	Current Limit Detection Output		TGON Output Signal		Servo Ready Output		Servo Alarm Output		
33	34	35	36	37	38	39	40	41	42	43	44	45	46	47	48	49	50
PAO	*PAO	PBO	*PBO	ALO1	ALO2	ALO3	S-ON	P-CON	P-OT	N-OT	ALM-RST	P-CL	N-CL	+24V IN	/	/	FG
Line Driver Output A ϕ		Line Driver Output B ϕ		Alarm Code Output Open collector Output			Servo ON Input	P-Drive Input	Forward Prohibit Input	Reverse Prohibit Input	Alarm Reset Input	Forward Current Limit ON Input	Reverse Current Limit ON Input	External Power Input	OPEN		Frame Ground

5.4.2 Connector 1CN for I/O Signals (Cont'd)

(2) I/O Signals and Connector 1CN

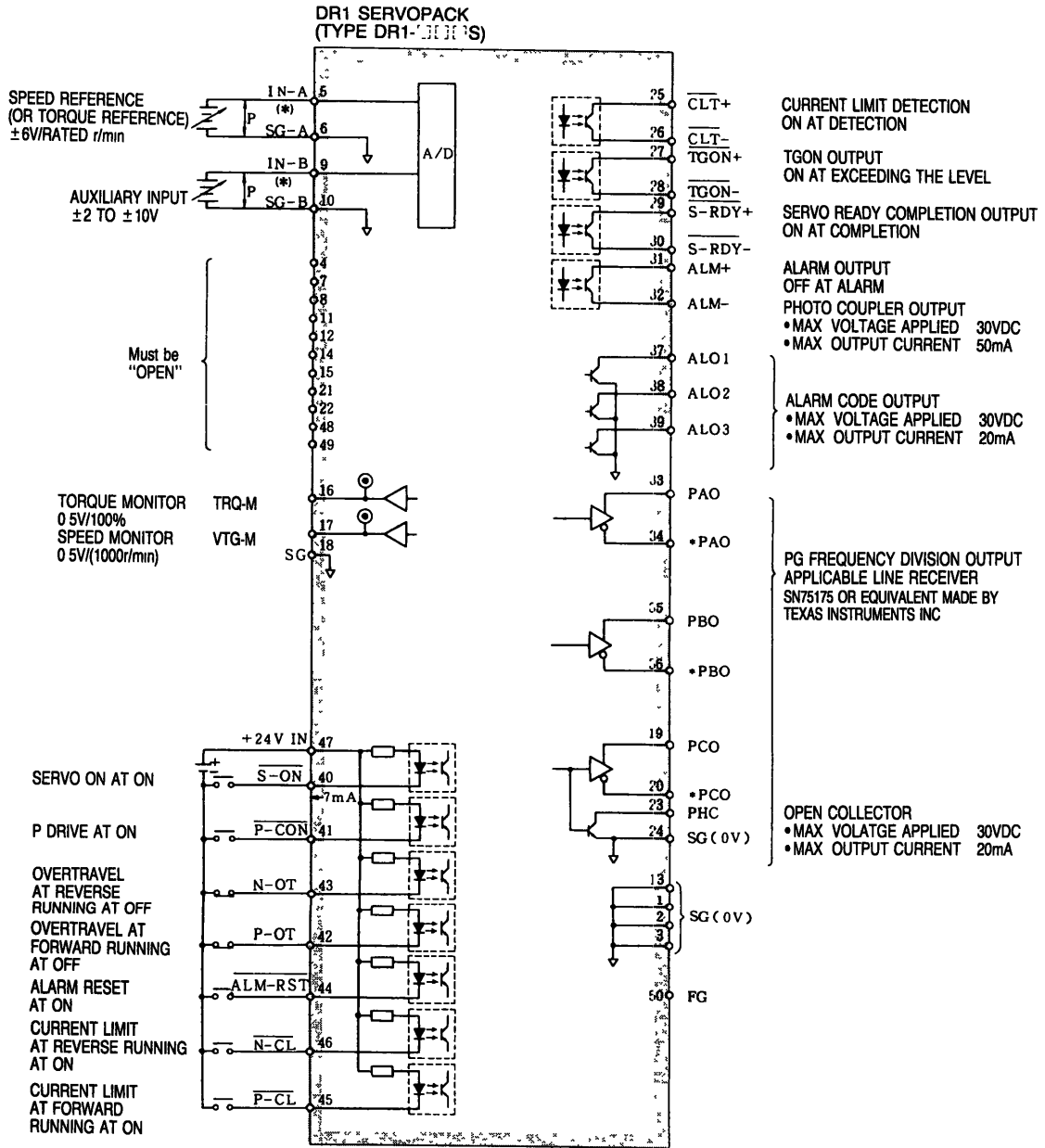

Fig 5.4 I/O Signals Connection and Connector 1CN

(3) Input Signals of Connector 1CN

Table 5.5 Input Signals

Signal Name	Connector 1CN No	Function	Description
$\overline{\text{S-ON}}$	40	Servo ON	<ul style="list-style-type: none"> Inputting this signal makes the SERVOPACK ready to receive speed reference inputs Base block and dynamic brake are cleared When Servo CN signal is not required, this signal can be disabled by setting user constant
$\overline{\text{P-CON}}$	41	Proportional drive reference (P drive)	Proportional control command to prevent drifting when the motor is left motionless without command input, while the main circuit is kept energized
		Zero-clamp drive reference	Inputting this signal maintains the motor in zero-speed (stop) status Prevents the motor from drifting
		Torque/speed changeover reference	In torque control II mode, this signal changes torque control to speed control
		External setting speed rotating direction reference	Inputs rotating direction reference at 1st to 3rd speed Used with 1st to 3rd speed selection signal input ($\overline{\text{N-CL}}$, $\overline{\text{P-CL}}$)
$\overline{\text{N-OT}}$	43	Reverse running prohibit	<ul style="list-style-type: none"> In the case of linear drive, etc., connect limit switch signal according to the run direction This is a normally closed contact
$\overline{\text{P-OT}}$	42	Forward running prohibit	<ul style="list-style-type: none"> This signal can be disabled by setting user constant Maintains the "N-OT at normal run" and "P-OT at normal run" status
+24VIN	47	24 V	External power supply to 1CN-40, -41, -42, -43, -44, -45 and 46 Use an external 24VDC (50mA min) power supply
IN-A	5 (6)	Speed reference input	$\pm 6\text{V}$, \pm rated speed is obtained
IN-B	9 (10)	Auxiliary reference input	± 2.0 to $\pm 10.0\text{V}$, \pm rated speed is obtained
		When either of IN-A or IN-B is used, be sure to set the unused input "Zero specification"	
$\overline{\text{N-CL}}$	46	Current limit at reverse running reference (1st to 3rd speed selection reference)	Current limit reference input or external setting speed (1st to 3rd speed) selection reference input is obtained by setting user constant Current limit value or set speed value is set by user constant
$\overline{\text{P-CL}}$	45	Current limit at forward running reference (1st to 3rd speed selection reference)	
$\overline{\text{ALM-RST}}$	44	Alarm reset	Resets the servo alarm status

5.4.2 Connector 1CN for I/O Signals (Cont'd)

(4) Input Circuit

There are seven input signals : Forward running prohibit, reverse running prohibit. Servo ON inputs, proportional drive circuits, overtravel prevention circuits, current limit circuits and alarm reset inputs. Construct the input circuit using 24V power supply (Figs. 5.2 and 5.3). Typical circuits are shown in Fig. 5.2.

NOTE

The user must provide the 24V power supply :
 $24 \pm 1\text{VDC}$, 50mA or more (approx. 7mA/circuit)

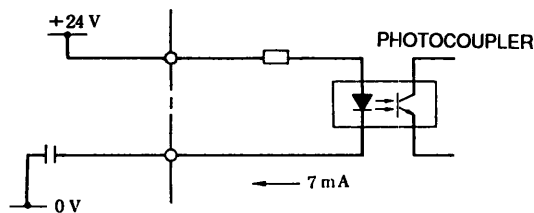

Fig 5 4 Configuration of I/O Circuit

① P-CON

This input signal functions as any of the following four signals depending on user constant.

(a) Proportional drive (P drive)

The drive may drift in open position loop. To avoid this, switch the speed amplifier from PI drive to P drive after the positioning and the loop gain in the control system drops and the drift decreases. With several percent of friction load, the motor stops completely.

(b) Zero clamp operation

After the motor stops, it may be locked electrically. This function is applicable vertical loads. Continuous operation torque in servo-lock may not exceed 70% of the motor's rated torque.

(c) Torque control/speed control changeover

In torque control mode II, this signal switches between torque and speed control.

(d) Rotation direction for user constant speed reference

Allows reversal of running direction, if user constant-speed reference mode is used.

② P-OT, N-OT (forward overtravel, reverse overtravel)

These circuits are used to stop the forward running of the motor (counterclockwise when viewed from the drive end of the motor) and reverse running. When the overtravel prevention circuit is not used, connect 1CN-② and -③ to the 0V external 24V power supply, or invalidate this function by setting user constant.

Operation to be performed when an overtravel occurs can be selected from the following four by setting user constant.

(a) Coasting to a stop

When overtravel occurs, the motor starts coasting to a stop.

(b) DB stop

When overtravel occurs, the motor is stopped by the dynamic brake. An user constant is used to determine whether the stopped motor is to be continuously locked by the dynamic brake or freed.

(c) Stop at the torque specified by user constant

When overtravel occurs, regardless of speed reference, the internal circuit forcibly changes speed reference to zero and immediately stops the motor. After the motor stops, it is released free.

(d) Zero-clamp after stopping at the torque specified by user constant

After the motor stops similar to (c) above, it is held in zero-clamp mode.

③ Servo ON [$\overline{S-ON}$]

Inputting this signal turns ON the power drive circuit of the SERVOPACK main circuit.

The motor cannot be started unless this signal is input (that is, in the serve-OFF status). When this signal is turned OFF while the motor is rotating, the motor is stopped by the dynamic brake. This signal is automatically input depending on setting of bit 0 of user constant.

④ $\overline{P-CL}$, $\overline{N-CL}$

These input signals function as any of the following two signals depending on user constant.

(a) External current limit at forward/reverse running reference

A circuit for suppressing motor armature current max. value during forward or reverse running (counterclockwise (CCW) when viewed from the drive end of the motor). The limit value can be specified independently for forward or reverse running by setting user constants. Regarding the continuous output current value as 100%, up to the maximum output current can be specified for the user constant.

When the motor is locked by applying current limit (at collision to stop, etc.), make setting so that the current limit value will be less than 70% of the continuous output current value.

(b) Internally set speeds (1st to 3rd) selection reference

The 1st to 3rd speeds are selected according to the inputs as shown in the following tables:

Table 5 6

	$\overline{N-CL}$	$\overline{P-CL}$
1st Speed	ON	OFF
2nd Speed	ON	ON
3rd Speed	OFF	ON
Stop (IN-A IN-B Input)	OFF	OFF

Table 5 7

	$\overline{P-CON}$
Forward Running	OFF
Reverse Running	ON

⑤ Alarm reset ($\overline{ALM-RST}$)

This is an external reset signal for servo alarm. Remove the cause of the alarm before restarting operation. For safety, set a 0V speed reference when inputting the reset signal.

5.4.2 Connector 1CN for I/O Signals (Cont'd)

(5) Output Signals

Table 5 8 Output Signals

Signal Name	Connector 1CN No	Function		Description
ALM	31 (32)	Servo alarm		<ul style="list-style-type: none"> • Goes OFF when fault is detected • For details, see Table 6 3, "Fault Detection Function "
$\overline{\text{TGON}}$	27 (28)	Rotation detection		Turns ON when the motor rotation speed exceeds the value specified by user constant
		Brake interlock output		<ul style="list-style-type: none"> • Outputs timing signal of external brake signal
$\overline{\text{CLT}}$	25 (26)	Current limit detection		<p>① When $\overline{\text{N-CL}}$ or $\overline{\text{P-CL}}$ is ON, this signal turns ON when the torque reaches the lower level value either limited by $\overline{\text{N-CL}}$ and $\overline{\text{P-CL}}$ or set by Cn-08 and Cn-09</p> <p>② When both $\overline{\text{N-CL}}$ and $\overline{\text{P-CL}}$ are OFF, this signal turns ON when the torque set by Cn-08 or Cn-09 is reached</p>
$\overline{\text{S-RDY}}$	29 (30)	Servo ready		Turns ON when main power supply ON and Servo alarm OFF
TRQ-M	16	Torque monitor		($\pm 0.5\text{V}/\text{rated torque}$) $\pm 10\%$ Load 1mA or less
VTG-M	17	Speed monitor		[$\pm 0.5\text{V}/1000\text{ r/min}$] $\pm 10\%$ Load 1mA or less
PAO * PAO PBO * PBO PCO * PCO	33 34 35 36 19 20	PG signal output	Phase-A, $\overline{\text{A}}$ Phase-B, $\overline{\text{B}}$ Phase-C, $\overline{\text{C}}$	<ul style="list-style-type: none"> • PG pulse after frequency division is output by line driver (SN75ALS194 made by TI) • To be received by a line receiver (SN75175 made by TI or equivalent)
PHC	23	PG signal output-2 Phase-C		Open collector output Max voltage applied 30VDC Max output current 20 mA
ALO1 ALO2 ALO3	37 38 39	Alarm output code (BCD code)		Open collector output Max voltage applied 30VDC Max output current 20 mA

5.5 CONNECTION (IN POSITION CONTROL MODE)

5.5.1 Connection Diagram

(1) Typical Connection for Position Control (Incremental Encoder Type DR1- C)

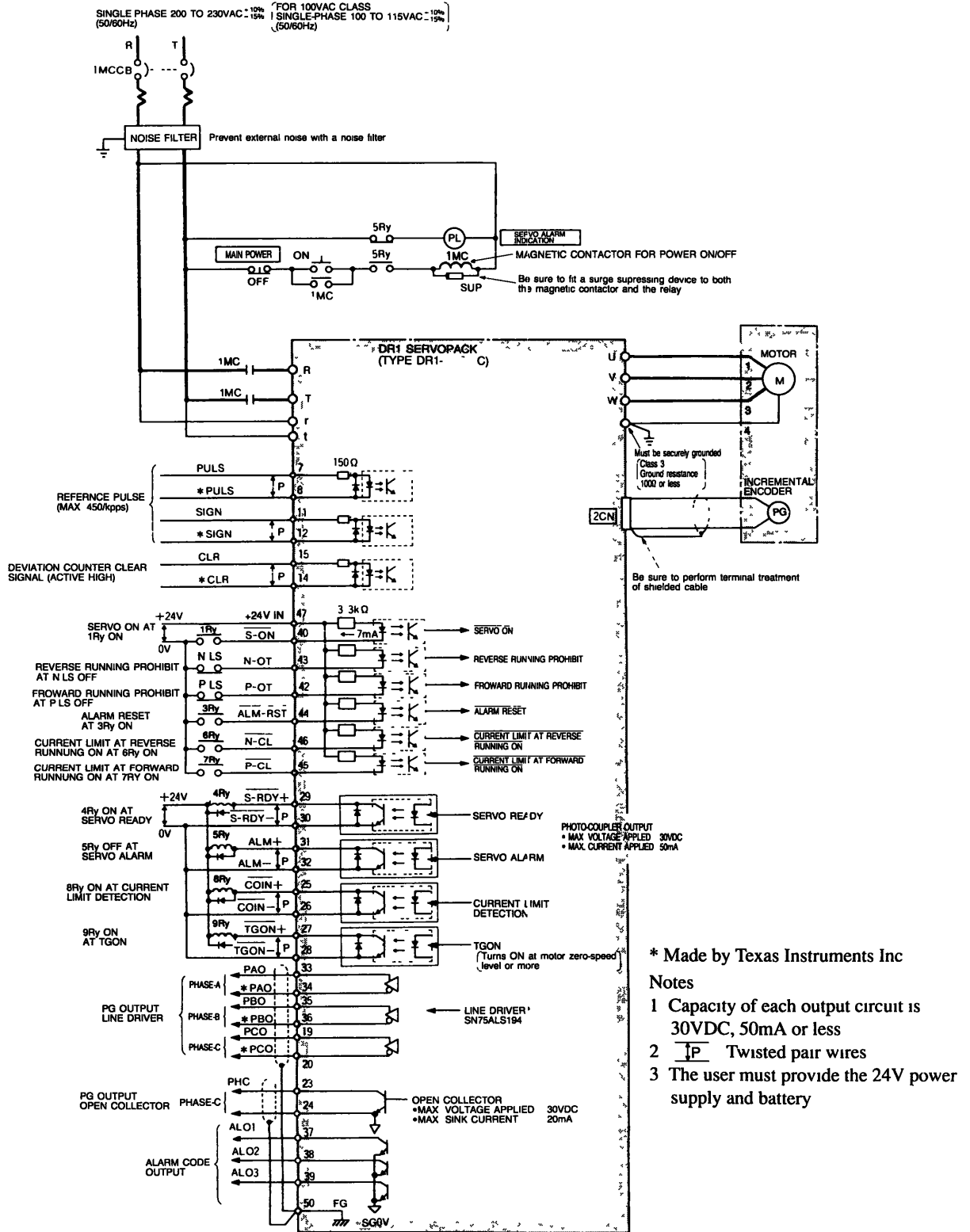

Fig 5.5 Example of Connection Diagram of DR1 SERVOPACK with a SERVOMOTOR and Peripherals

5.5.2 Connector 1CN for I/O Signals

(1) Connector 1CN Layout

Table 5.9 Connector 1CN Layout of DR1 SERVOPACK

1	2	3	4	5	6	7	8	9	10	11	12	13	14	15	16	17	18
SG	SG	SG	/	/	SG	PLUS	*PLUS	/	SG	SIGN	*SIGN	SG	*CLR	CLR	TRQ-M	VTG-M	SG
GND		OPEN		GND	Reference Pulse Input		OPEN	GND	Reference Sign Input		GND	Clear Input		Speed Monitor		Torque Monitor	
		19	20	21	22	23	24	25	26	27	28	29	30	31	32		
		PCO	*PCO	/	/	PHC	SG	COIN +	COIN -	TGON +	TGON -	S-RDY +	S-RDY -	ALM +	ALM -		
		Line Driver Output C ϕ		OPEN		Open Collector Output C ϕ	GND	Positioning Completion Signal		TGON Output Signal		Servo Ready Output		Servo Alarm Output			
33	34	35	36	37	38	39	40	41	42	43	44	45	46	47	48	49	50
PAO	*PAO	PBO	*PBO	ALO1	ALO2	ALO3	S-ON	P-CON	P-OT	N-OT	ALM-RST	P-CL	N-CL	+24V IN	/	/	FG
Line Driver Output A ϕ		Line Driver Output B ϕ		Alarm Code Output Open Collector Output			Servo ON Input	P Drive Input	Forward Prohibit Input	Reverse Prohibit Input	Alarm Reset Input	Forward Current Limit ON Input	Reverse Current Limit ON Input	External Power Input	OPEN		Frame Ground

(2) I/O Signals and Connector 1CN

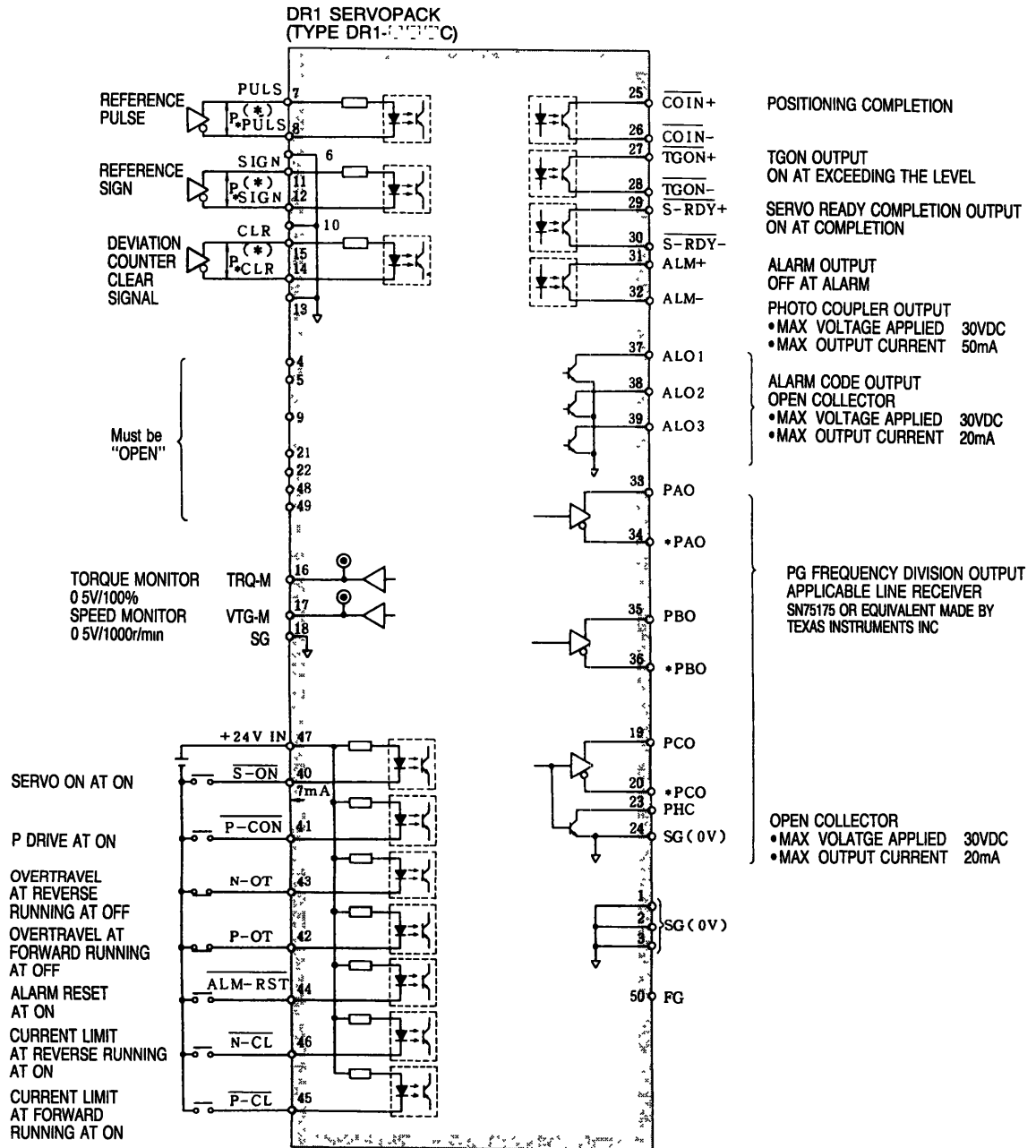

* \overline{IP} Twisted pair wires

Notes

1. Cable for 1CN is not provided
2. The user must provide the 24V power supply

Fig 5.6 I/O Signals Connection and Connector 1CN

5.5.2 Connector 1CN for I/O Signals (Cont'd)

(3) Input Signals of Connector 1CN

Table 5 10 Input Signals

Signal Name	Connector 1CN No	Function	Description
$\overline{\text{S-ON}}$	40	Servo ON	<ul style="list-style-type: none"> Inputting this signal makes the SERVOPACK ready to receive speed reference inputs Base block and dynamic brake are cleared When Servo ON signal is not required, this signal can be ineffective by setting user constant
$\overline{\text{P-CON}}$	41 (2 functions can be selected by setting the user constant)	Proportional drive reference (P-drive)	<ul style="list-style-type: none"> This signal switches the speed amplifier from PI drive to P drive
		INTERNAL setting speed rotating direction reference	Inputs rotating direction reference at 1st to 3rd speed Used with 1st to 3rd speed selection signal input ($\overline{\text{N-CL}}$, $\overline{\text{P-CL}}$)
N-OT	43	Reverse running prohibit	<ul style="list-style-type: none"> In the case of linear motion, etc., connect limit switch signal according to the run direction. Since it is a bar signal (reverse signal), it is "Closed" during normal run. When limit switch is tripped, it becomes "OPEN"
P-OT	42	Forward running prohibit	<ul style="list-style-type: none"> This signal can be ineffective by setting user constant. Maintains the "N-OT at normal run" and "P-OT at normal run" status
+24VIN	47	24V	External power supply to 1CN-40, -41, -42, -43, -44, -45 and -46 Prepare a 24VDC (50mA min) power supply
PULS (*PULS)	7 (8)	Reference pulse input	Pulse train frequency (Max) $\leq 450\text{kpps}$ When phase-A and -B pulses are used by input multiplier Pulse train frequency \times input multiplier $\leq 800\text{kpps}$
SIGN (*SIGN)	11 (12)	Reference sign input	Sign reference forward run reference H level, reverse run reference H level, For details, refer to Par 6.4 "POSITION CONTROL MODE"
CLR (*CLR)	15 (14)	Deviation counter clear signal	Interrupts reference F and B pulse to clear the deviation counter at H level
$\overline{\text{N-CL}}$	46	Current limit at reverse running reference (1st to 3rd speed selection reference)	Current limit reference input or external setting speed (1st to 3rd speed) selection reference input is obtained by setting user constant Current limit value or set speed value is set by user constant
$\overline{\text{P-CL}}$	45	Current limit at forward running reference (1st to 3rd speed selection reference)	
$\overline{\text{ALM-RST}}$ *	44	Alarm reset	Resets the servo alarm status

* · Positional deviation counter operates at alarm occurrence

When the alarm is released, set "H" to the clear input signal or turn OFF the control power supply to clear the lag pulse in the positional deviation counter

If there are lag pulses in the positional deviation counter at servo OFF, it operates for the length of lag pulse at servo ON
To avoid this movement, set "H" to the clear input signal before servo ON.

(4) Input Circuit

Input signals are the same as those of the SERVOPACK with speed control mode except for P-drive reference input. As for PULS, SIGN and CLR signals, see Par. 6.4 "Position Control Mode".

(5) Output Signals

Table 5 11 Output Signals

Signal Name	Connector 1CN No	Function		Description
ALM	31 (32)	Servo alarm		<ul style="list-style-type: none"> Goes OFF when fault is detected For details, see Table 6 3, "Fault Detection Function "
$\overline{\text{TGON}}$	27 (28)	Rotation detection		Turns ON when the motor rotation speed exceeds the value specified by user constant
		Brake interlock output		Outputs timing signal for external brake signal
$\overline{\text{COIN}}$	25 (26)	Positioning completion signal		Outputs when the deviation counter lag pulse is within the set value of user constant
$\overline{\text{S-RDY}}$	29 (30)	Servo ready		Goes ON when main circuit power supply ON and no servo alarm occurs
TRQ-M	16	(Torque/reference) monitor		Torque monitor ($\pm 0.5\text{V}/\text{rated torque}$) $\pm 10\%$ } Load Lag pulse monitor ($\pm 0.5\text{V}/1000\text{r}/\text{min}$) $\pm 10\%$ } 1mA or less Both can be set by user constant
VTG-M	17	(Speed/lag pulse) monitor		Speed monitor ($\pm 0.5\text{V}/1000\text{r}/\text{min}$) $\pm 10\%$ } Load Reference speed monitor ($\pm 1.5\text{V}/50\text{ pulse}$) $\pm 10\%$ } 1mA or less Both can be set by user constant
PAO * PAO PBO * PBO PCO * PCO	33 34 35 36 19 20	PG signal output	Phase-A, $\overline{\text{A}}$ Phase-B, $\overline{\text{B}}$ Phase-C, $\overline{\text{C}}$	<ul style="list-style-type: none"> PG pulse after frequency division is output by line driver (SN75ALS194 made by TI) To be received by a line receiver (SN75175 made by TI or equivalent)
PHC	23	PG signal output 2 Phase-C		Open collector output Max voltage output 30VDC Max output current 20 mA
ALO1 ALO2 ALO3	37 38 39	Alarm output code (BCD code)		Open collector output Max voltage applied 30VDC Max output current 20 mA

5.6 OUTPUT CIRCUIT

There are eight output signals :

Current limit detection (positioning completion in position control mode), $\overline{\text{TGON}}$, servo alarm, servo ready, PG phase C signal alarm codes for open collector output.

These output circuits are non-contact, employing transistors. Voltage and current specifications are :

Applied Voltage (V Max) $\leq 30\text{V}$

Conduction Current (I_p) $\leq 50\text{mA}$

For alarm codes 1 to 3, I_p is 20mA max.

NOTE

The output circuit requires a separate power supply (20mA max. for open collector output). It is recommended to use the same 24V power supply used for the input circuit (Fig.5.7).

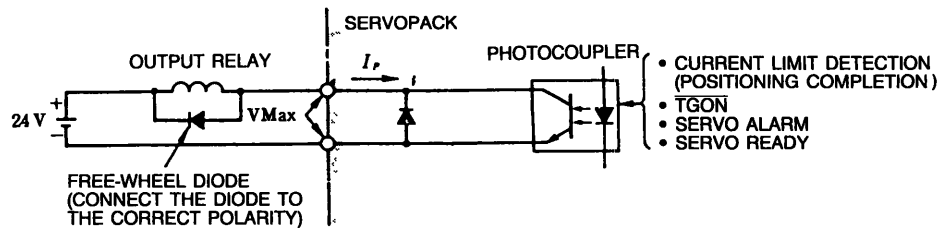

Fig 5 7 Output Circuit

5.6.1 Optical Encoder (PG) Output Circuit

[PAO, *PAO, PBO, *PBO, PCO, *PCO]

Outputs PG phase-A, -B, and -C (reference) signals. Use as position signals. Specifications of output signals are as follows.

(1) Signal Form

Two-phase pulse with 90-degree phase difference for phase-A, -B and reference pulse for phase-C.

(2) Output Circuit and Receiver Circuit

Two types of output circuits are provided :
 line driver output and open collector output (phase-C only).
 Fig. 5.8 shows an example of line driver output.

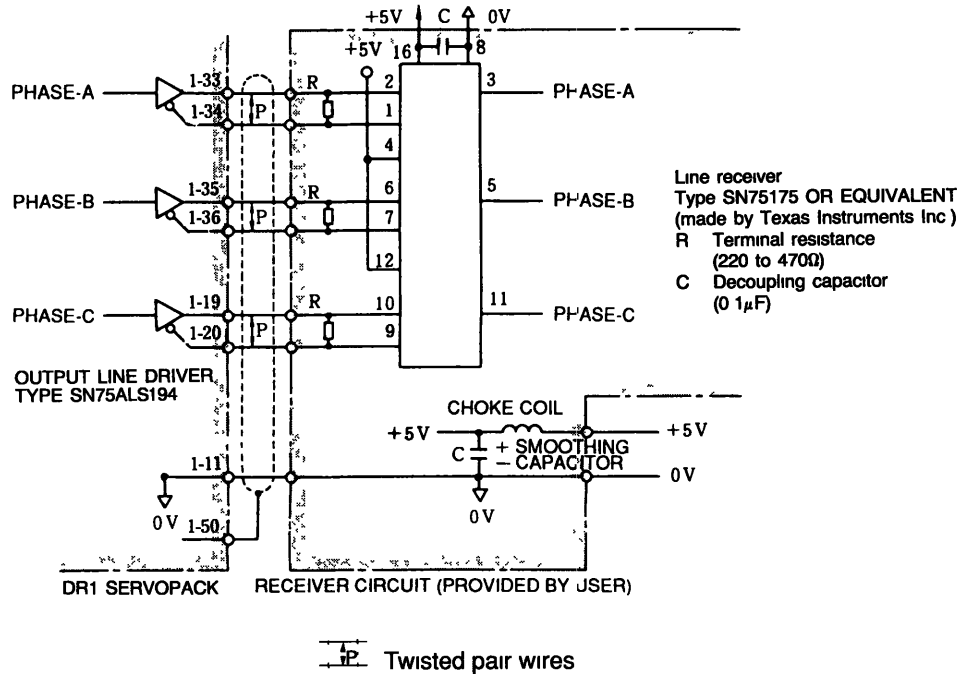
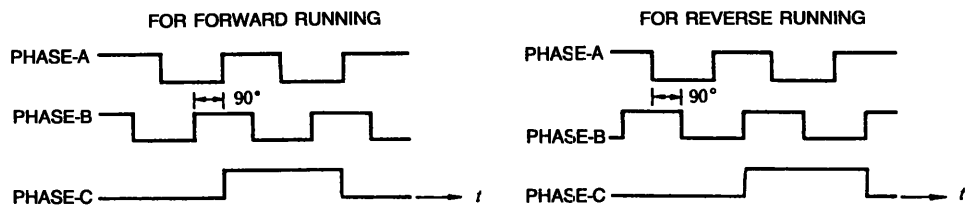

Fig 5 8 Example of Output Circuit and Receiver Circuit

(3) Output Phase (Frequency dividing ratio : 1/1)



Note For details of frequency dividing, refer to Par 7 (8), "PG Division Ratio Setting"

Fig 5 9 Forward/Reverse Output Phase

5.6.2 Holding Brake Interlock Signal

The brake signal output, which is dependent on the motor circuit conduction state and motor rotating speed, can be generated.

<Setup Procedure>

When the user constant (memory switch) is set to provide the braking function, the brake interlock signal (\overline{BK} signal) output is generated from the 1CN-27, 28 (\overline{TGON}). The time interval t_B [$\times 10\text{ms}$] between braking and motor conduction termination is determined by user constant Cn-12.

Table 5.12 Timing with Servo ON signal and Main Circuit Power Supply

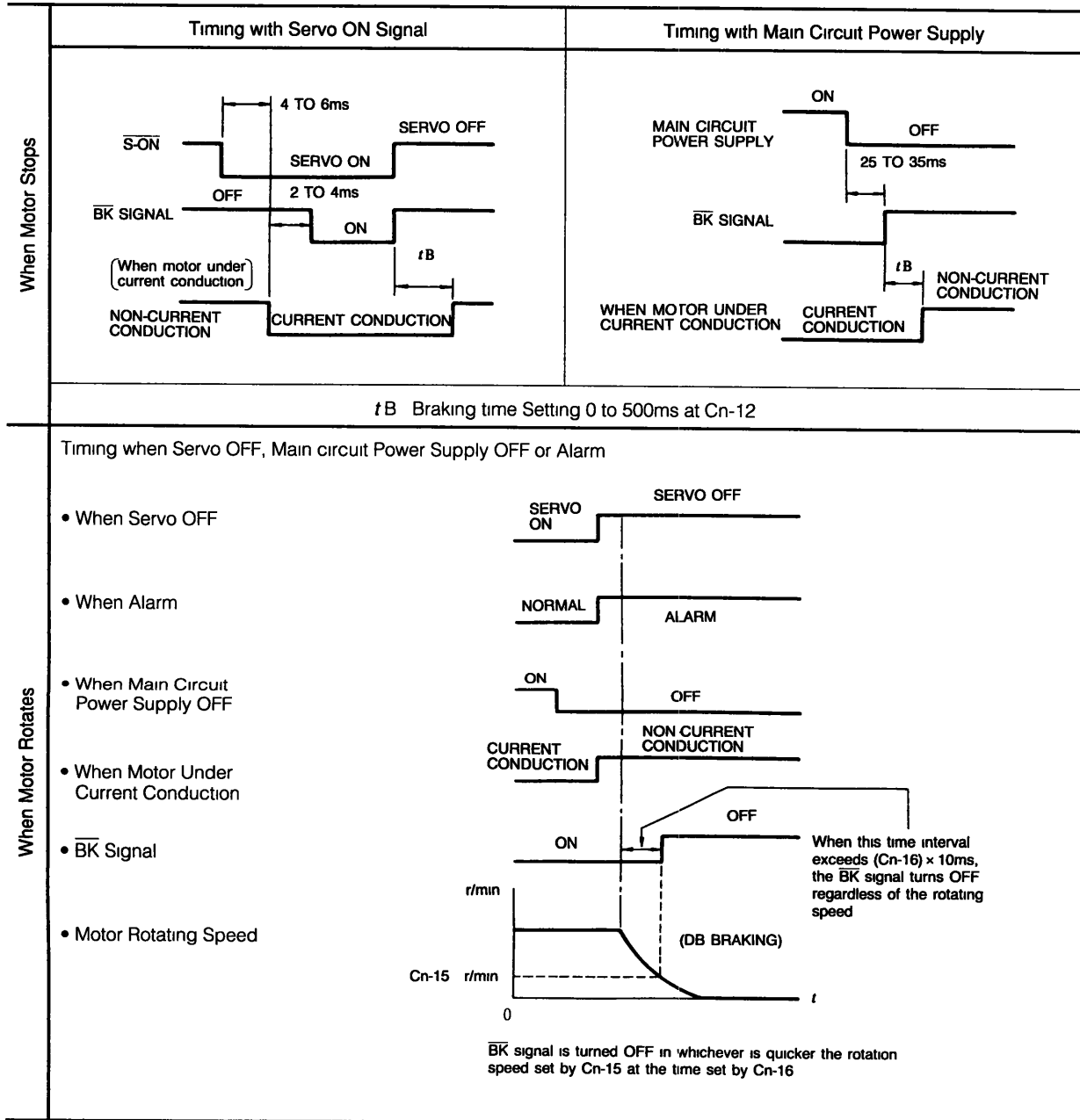

5.7 CONNECTOR 2CN FOR OPTICAL ENCODER

5.7.1 Connector 2CN Layout

Table 5 12 Connector 2CN Layout of DR1 SERVOPACK

1	2	3	4	5	6	7
PG0V	PG0V	PG0V	PG5V	PG5V	PG5V	DIR *
	8	9	10	11	12	13
14	15	16	17	18	19	20
PC	*PC	PA	*PA	PB	*PB	FG

* As for DIR, refer to Par 6 9 1 “Connection for Reverse Motor Running”

5.7.2 Cable Specifications

If required, order in units of standard lengths as shown in Table 5.13.

Table 5.13 Cable Specifications

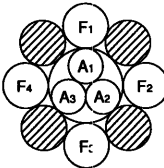
YASKAWA Drawing No	Incremental Encoder B9400064		
General Specifications	Double KQVV-SW AWG22 × 3C AWG26 × 4P		
Finishing Dimensions	φ 7.5 mm (φ 0.30 in.)		
Recommended Receptacle Type			
Internal Composition and Lead Color	A1	Red	
	A2	Black	
	A3	Green yellow	
	F1	Blue/White blue	Twisted pair wires
	F2	Yellow/White yellow	Twisted pair wires
	F3	Pale green/White pale green	Twisted pair wires
	F4	Orange/White orange	Twisted pair wires
YASKAWA Standard Specifications	Standard lengths 3m, 5m, 10m, 15m, 20m *		

* Terminal ends are provided without connectors. For cables with connectors, see Par 10.5, "CABLES."

Note: Allowable wiring distance between DR1 SERVOPACK and SGM SERVOMOTOR (PG) is 20m max.

5.7.3 Connection

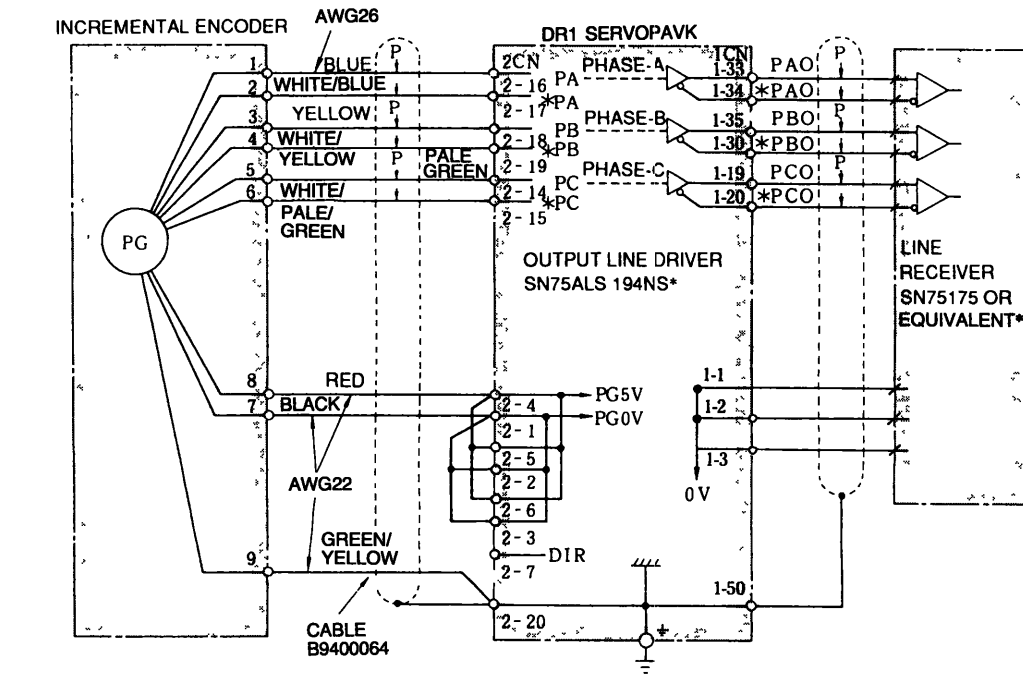

P
Twisted pair wires

* Made by Texas Instruments Inc

Fig 5 10 Connector 2CN for Incremental Encoder Connection and ICN Output Processing (When using Connection Cable B9400064)

6. OPERATION

6.1 POWER ON AND OFF

Arrange the sequence so that the power is simultaneously supplied to the main circuit (R,T) and the control circuit (r,t), or supplied to the control circuit first, then to the main circuit (Figs. 6.1 and 6.2).

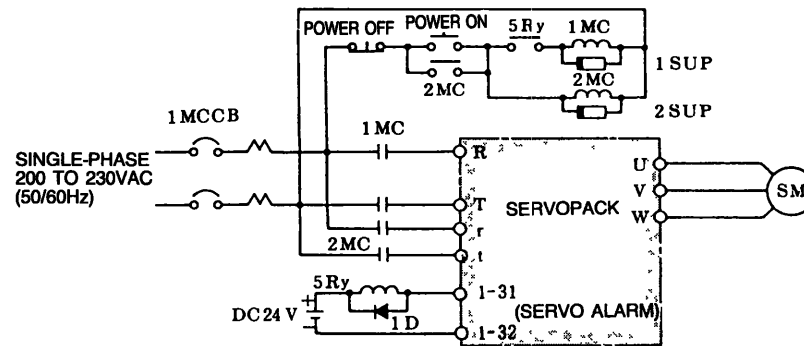

Fig 6.1 Connection Example for Power ON/OFF (200VAC)

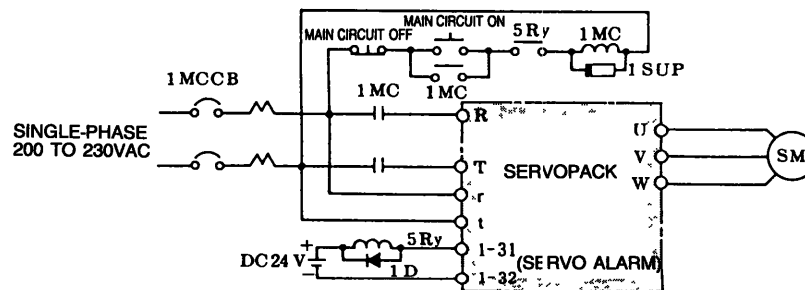

Fig 6.2 Connection Example for Main Circuit Power ON/OFF (200VAC)

Arrange the sequence so that the power is simultaneously cut (including momentary power failure) (Fig. 6.1), or the power to the main circuit is cut first, then the control circuit (Fig. 6.2). The order is the reverse of the power ON sequence.

Precautions for Connections in Fig. 6.1 are as follows.

- Make sequence to assure that the main circuit power will be cut OFF by a servo alarm signal. (The alarm information is written on E² PROM, so when the power is simultaneously cut, the alarm subject can be checked with the power resupplied.)
- When power is supplied to the power ON/OFF sequence shown in Fig. 6.1, the normal signal is set (5Ry is turned ON) in the control circuit after a maximum delay of 2 seconds.

NOTE

When the power is turned ON, a servo alarm signal continues for approximately 2 seconds to initialize the DR1 SERVOPACK.

- Since DR1 SERVOPACK is of a capacitor input type, large in-rush current flows when the main circuit power is turned ON (recharging time : 0.2s.). If the power is turned ON and OFF frequently, the in-rush current limit resistor may be degraded and a malfunction may occur. When the motor starts, turn ON the speed reference and turn it OFF when the motor stops. Do not turn the power ON or OFF.

6.2 SPEED REFERENCE

6.2.1 Speed Reference Circuit

From the external power, the speed reference voltage is given to input 1CN- ⑤ and ⑥ or 1CN- ⑨ and ⑩. The method for giving speed reference voltage is shown below.

(1) For accurate (inching) speed setting

- 25 HP-10B type : Multiple-rotation type, wire wound variable resistor (with dial MD 10-30B4).

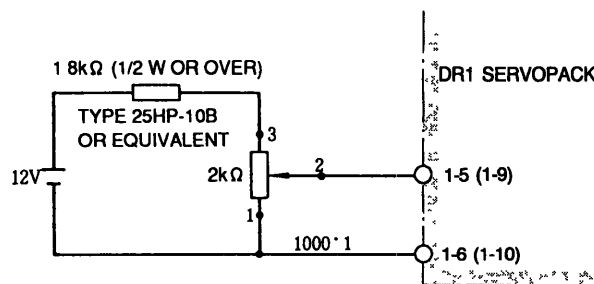

(a) When Multiple-Rotation Type, Wire-Wound Variable Resistor is used

6.2.1 Speed Reference Circuit (Cont'd)

- RV30YN type : Carbon-film variable resistor.
- Low-and-high-speed relays : Reed relays

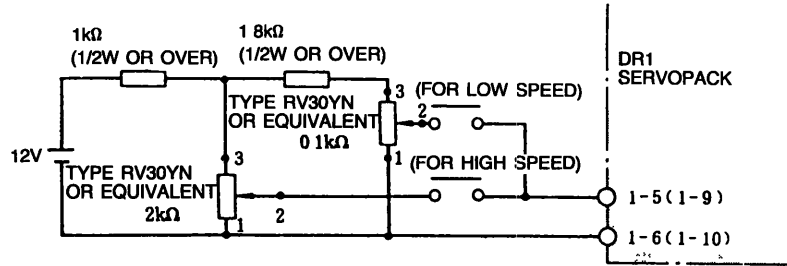

Note When a carbon resistor is used, great residual resistance remains, so the speed control range becomes approximately 500 : 1

(b) When Carbon Variable Resistor is used

Fig 6.3 Method for Giving Speed Reference Voltage
(for Accurate Speed Setting)

(2) For relatively rough speed setting

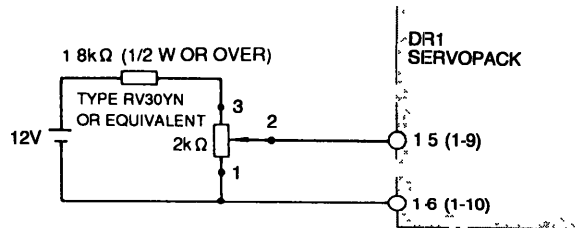

Note When a carbon resistor is used, great residual resistance remains, so the speed control range becomes about 500 : 1

Fig 6.4 Method for Giving Speed Reference Voltage
(for relatively rough speed setting as compared with Fig 6.2)

6.2.2 Stop Reference Circuit

When giving a stop reference, do not open the speed reference circuit (1CN-⑤ or ⑨), but set to 0V.

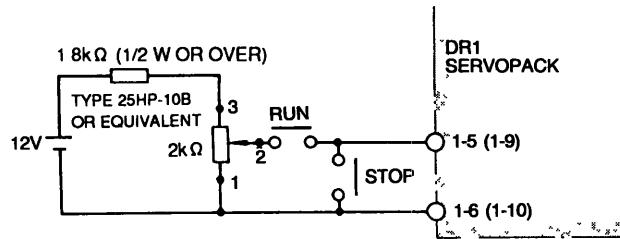

(a) When Multiple-Rotation Type, Wire-Wound Variable Resistor is used

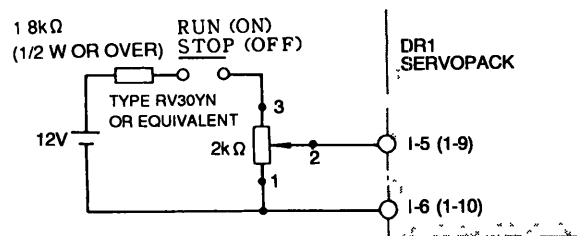

(b) When Carbon Variable Resistor is used

Fig 6 5 Method for Giving Stop Reference

6.2.3 Handling of Speed Reference Input Terminal

The unused terminals, out of the speed reference terminals ICN-⑤, ⑥ and the auxiliary input terminal ICN-⑨, ⑩ must be short-circuited or select “Zero-speed Reference” with user constant setting.

6.2.4 Auxiliary Reference Circuit (± 2 to ± 10 V)

Auxiliary reference input circuit is used for application at rated reference voltage other than ± 6 V.

• Adjustment procedures

For user constant setting of auxiliary input reference, input motor rotation per 1V (r/min)/V to user constant Cn-03 by digital operator (type JUSP-OP02A).

When combined with Yaskawa POSITIONPACK in positioning system drive, auxiliary reference input terminals are normally used as speed reference input. In this case, positioning loop gain is adjusted with the user constant Cn-03.

6.2.5 Speed Control with Zero Clamp

Speed control with zero clamp mode can be selected by setting bits A and B of user constant Cn-01.

In this mode, after motor rotation speed falls below the set value of user constant Cn-0F, speed reference is regarded as "0" and the motor speed is reduced to zero. While the motor is stopped, position loop keeps it in servo-lock status.

- Turning ON $\overline{P-CON}$ signal starts zero-clamp operation.
- In zero-clamp speed control mode, P/PI control cannot be switched like usual speed control mode since the $\overline{P-CON}$ signal is used for turning the zero clamp function ON/OFF signal.

6.2.6 Soft Start Function

Motor accel/decel time can be set up.

<Setup procedure>



Set the time in milliseconds accelerating to the maximum motor rotation speed(ms) to user constant Cn-07.

6.2.7 Jog Operation

The motor can be operated from the digital operator without entering speed reference during operation. Jog speed (r/min) can be varied depending on the value set to user constant Cn-10.

6.2.8 Internal Setting Speed Control

Internal setting speed control mode can be selected by setting bit 2 of user constant Cn-02.

In this mode, input value (1st to 3rd speeds) specified for user constants Cn-1F to Cn-21 can be used.

To select the speeds, use contact inputs $\overline{P-CL}$ and $\overline{N-CL}$. Specify the direction of rotation by $\overline{P-CON}$ input.

In this mode, the current limit function and the P/PI switch function are unavailable.

6.3 TORQUE CONTROL MODE

In the torque control mode, speed loop is disconnected and the motor is driven by torque reference.

In this mode, torque control I or torque control II can be selected by setting bit A or B of user constant Cn-01.

6.3.1 Torque Control I

In torque control I, torque reference voltage is applied from external power supply across terminals 5 and 6 of 1CN.

3 V/rated torque are preset at the factory prior to shipment. They can be changed by user constant Cn-13. Additionally, speed limit value can be set by user constant Cn-14. Cn-14 is effective only at torque control I.

Examples of giving torque reference voltage are shown in the following.

(1) For accurate (inching) torque setting

In Figs. 6.5 and 6.6, 1-1 and 1-2 are the input terminal number of SERVOPACK.

- 25HP-10B type : Multiple-rotation type, wire-wound variable resistor (with dial MD10-30B4).

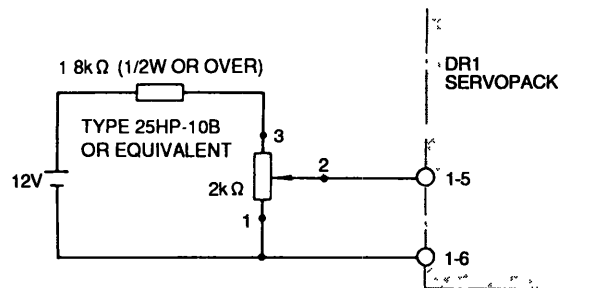

(a) When Multiple-rotation Type, Wire-Wound Variable Resistor is used

- RV30YN type : Carbon-film variable resistor.
- Low-and high-speed relays : Reed relays

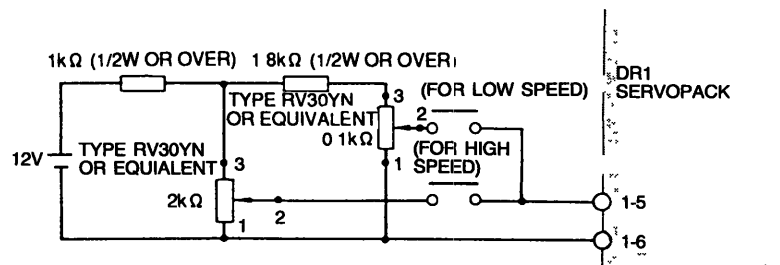

Note · When a carbon resistor is used, great residual resistance remains, so the torque control range becomes approximately 500 : 1

(b) When Carbon Variable Resistor is used

Fig 6.6 Method of Giving Torque Reference Voltage (for accurate torque setting)

6.3.1 Torque Control I (Cont'd)

(2) For relatively rough torque setting

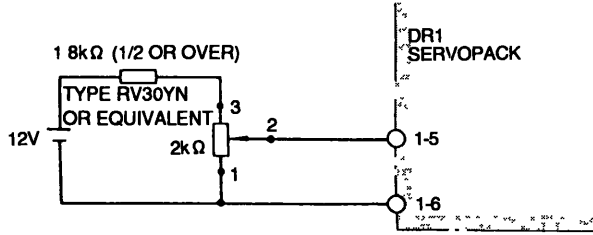

Note . When a carbon resistor is used, great residual resistance remains, so the torque control range becomes approximately 500 1

Fig 6 7 Method for Giving Torque Reference Voltage (for relatively rough torque setting)

6.3.2 Torque Control II (Torque Control with Speed Limit + Speed Control)

- In torque control II, torque control is performed along with speed control using the motor speed limit function. Switching from torque control to speed control can be accomplished by turning $\overline{P-CON}$ signal ON.
- In torque control II, $\overline{P-CON}$ signal is used for switching torque control and speed control so that P/PI control cannot be switched like during usual speed control. An external power supply applies torque reference voltage across terminals 9 and 10 of input 1CN, and speed limit voltage (both forward and reverse sides speed limit at positive voltage) across terminals 5 and 6 of input 1CN. 3 V/rated torque are preset at the factory prior to shipment. Examples of giving torque reference voltage and speed limit voltage are shown in the following.

(1) For accurate (inching) torque or speed limit setting

The input terminal numbers of the DR1 SERVOPACK shown in Figs. 6.8 and 6.9 are for entering torque reference voltage. Terminal numbers in parentheses are for entering speed limit voltage.

- 25HP-10B type : Multiple-rotation type, wire-wound variable resistor (with dial MD10-30B4).

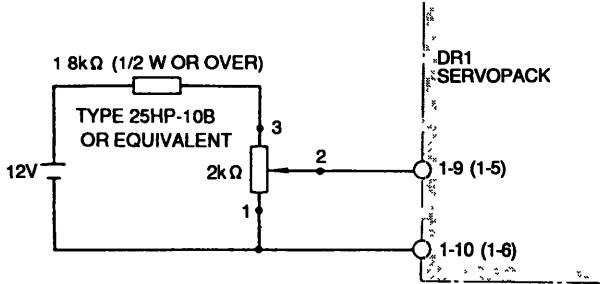

(a) When Multiple-rotation Type, Wire-Wound Variable Resistor is used

6.3.2 Torque Control II (Torque Control with Speed Limit + Speed Control) (Cont'd)

- RV30YN type : Carbon-film variable resistor.
- Low-and high-speed relays : Reed relays

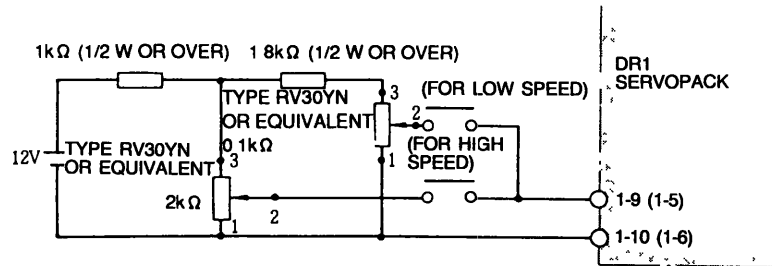

Note When a carbon resistor is used, great residual resistance remains, so the torque control range becomes approximately 500 : 1

(b) When carbon variable resistor is used

Fig 6 7 Method for Giving Torque Reference/Speed Limit Voltage (for accurate torque or speed limit setting)

(2) For relatively rough torque or speed limit setting

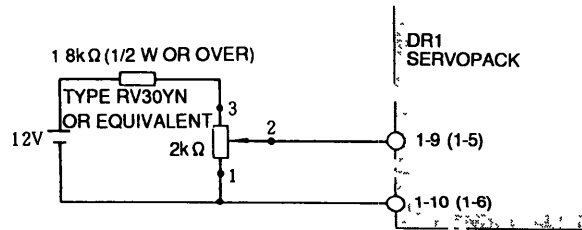

Note When a carbon resistor is used, great residual resistance remains, so the torque control range becomes approximately 500 : 1.

Fig 6 8 Method for Giving Torque Reference/Speed Limit Voltage (for relatively rough torque or speed limit setting)

6.4 POSITION CONTROL MODE

The position control mode can be set by user constant Cn-02 bit No. B (refer to Par. 7 “USER CONSTANTS”). The position control is performed by inputting two reference pulse trains between ICN-⑦ and ⑧, and ICN-⑩ and ⑪.

This mode is effective when the input reference pulse CLR (CLEAR) input signal is in the “L” level status.

6.4.1 Input Reference Pulse Logical Level

For input reference pulse, positive logic (active H) and negative logic (active L) can be selected.

It can be set by logical level selection (user constant Cn-02 bit D).



Positive logic is set prior to shipping.

6.4.2 Reference Pulse Form

Signals in three types of forms can be input as reference pulses.

According to the reference pulse form and input multiplier (only for two-phase signals), set user constant (bit 3, 4 or 5) as shown in Table 6.1 to use.

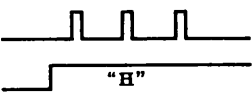
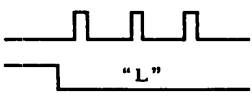
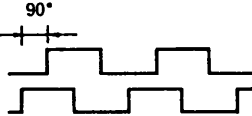
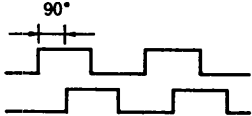
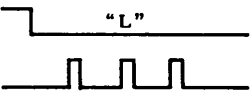
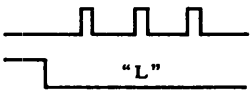
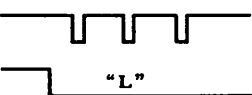
Table 6.1 Reference Pulse Form

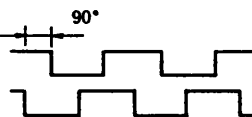
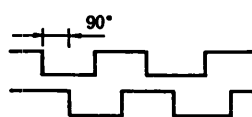
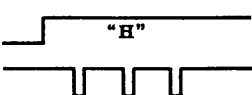
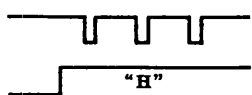
	Reference Pulse Form	Input Pin No	Motor Forward	Motor Reverse Run	Input* Multiplier	Cn-02		
						3	4	5
Positive Logic Setting (Cn-02 Bit D=0)	Sign + Pulse Train	1CN-⑦ 1CN-⑩			—	0	0	0
	90° Phase Difference* 2-phase Pulse Train (×1, ×2, ×4 possible)	1CN-⑦ 1CN-⑩			×1	0	1	0
					×2	1	1	0
					×4	0	0	1
CW Pulse Train + CCW Pulse Train	1CN-⑦ 1CN-⑩			—	1	0	0	
Negative Logic Setting (Cn-02 Bit D=1)	Reference Pulse Form	Input Pin No	Motor Forward Run	Motor Reverse Run	Input* Multiplier	Cn-02		
	Sign + Pulse Train	1CN-⑦ 1CN-⑩			—	0	0	0
	90 Phase Difference* 2-phase Pulse Train (×1, ×2, ×4 possible)	1CN-⑦ 1CN-⑩			×1	0	1	0
					×2	1	1	0
×4					0	0	1	
CW Pulse Train + CCW Pulse Train	1CN-⑦ 1CN-⑩			—	1	0	0	

* Input multiplier is possible with 90° phase difference 2-phase pulse train input

Positional deviation counter operates during baseblock. If there are lag pulses, the positional deviation counter operates for the length of lag pulse at servo ON. To avoid this movement, set the clear input signal to “H” before servo ON.

6.4.3 Reference Pulse Timing

Table 6.2 shows the timing pulse waveform in positive logic. In negative logic, the conditions are the same.

Table 6 2 Allowable Voltage Level and Timing

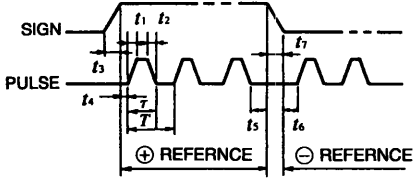
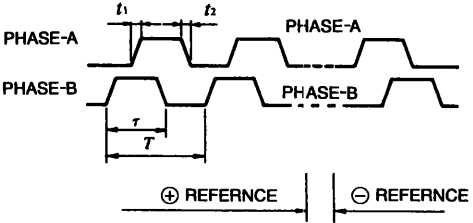
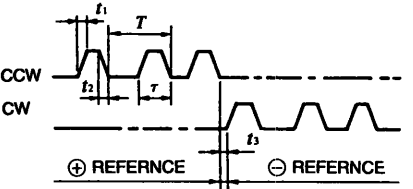
Item	Electrical Specifications	Remarks
<p>Sign + Pulse Train Input (SIGN + PULSE Signals)</p> <p>Max Reference Frequency 450 kpps</p>	 <p>$t_1, t_2 \leq 0.1 \mu\text{s}$ $\tau \geq 1 \mu\text{s}$ $t_3, t_4 \leq 0.1 \mu\text{s}$ $t_5, t_6 > 3 \mu\text{s}$</p>	<p>Sign (SIGN) H becomes positive reference and L becomes negative reference</p>
<p>90° Phase Difference 2-phase Pulse (Phases A+B)</p> <p>Max Reference Frequency ×1 450 kpps ×2 400 kpps ×4 200 kpps</p>	 <p>$t_1, t_2 \leq 0.1 \mu\text{s}$ $\tau \geq 1 \mu\text{s}$ $\frac{\tau}{T} \times 100 \leq 50\%$</p>	<p>Multiplier mode changeover is set by user constant Cn-02 (bits 3, 4 and 5)</p>
<p>CCW Pulse + CW Pulse</p> <p>Max Reference Frequency 450 kpps</p>	 <p>$t_1, t_2 \leq 0.1 \mu\text{s}$ $\tau \geq 1 \mu\text{s}$ $t_3 > 3 \mu\text{s}$ $\frac{\tau}{T} \times 100 \leq 50\%$</p>	

6.4.4 Reference Pulse (Including CLR Input) Interface

Line driver output, +12V or +5V open collector can be applied. Each input circuit is shown below.

(a) Line driver output

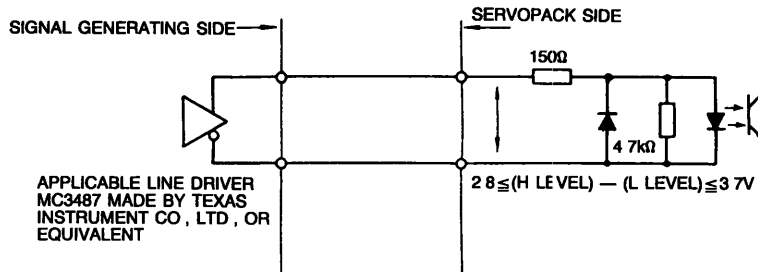

Fig 6 10

(b) Open Collector

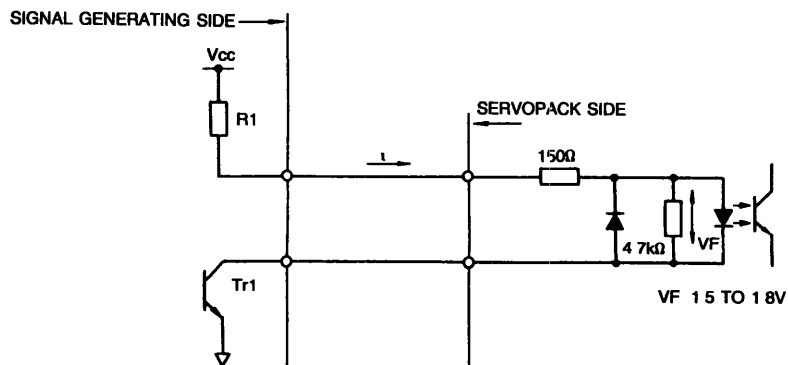

Fig 6 11

Set pull-up resistance R1 value so that input current i will be within the range of 6.6 to 15.3mA.

Typical Application

- Vcc is 12V ± 5%
- R1 = 1000Ω
- Vcc is 5V ± 5%
- R1 = 180Ω

When reference pulse is open collector, in Table 6.2, it is equivalent to : "H" level input when Tr1 is turned ON.

"L" Level input when Tr1 is turned OFF.

6.4.5 Clear Input Signal (CLR)

By setting “H” to the CLR signal, the position deviation counter value becomes zero and the position loop does not work. Use the signal at “L” under normal operation.

6.4.6 Position Completion Signal ($\overline{\text{COIN}}$)

This signal is output when the deviation counter lag pulse is within the set value of user constant (Cn-1B).

When this positioning completion width is converted to the motor rotation angle, the following value can be obtained : $\frac{D}{N \times M}$ (rev)

D : Positioning completion width (Cn-1B)

N : PG division number (Cn-0A)

M : FB pulse multiplier (Cn-02 bits 8, 9)

6.4.7 I/O Signal Timing

Fig. 6.12 shows typical I/O signal timing. (PG division ratio = 1, output multiplier = 1, positioning completion width = ± 1 pulse)

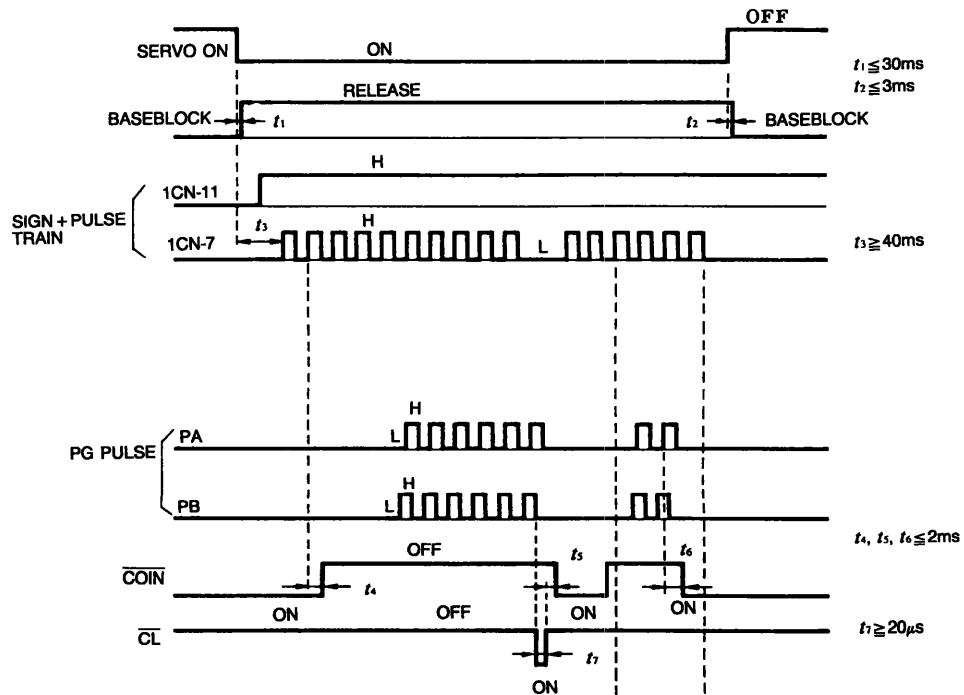

- 1 40ms or more is needed from when the servo ON signal is turned ON to when the reference pulse is input. If the reference pulse is input within 40ms from when the servo ON signal is turned ON, the reference pulse may not be input.
- 2 20 μs or more is needed before the clear signal is turned ON. If the signal is turned ON within 20 μs , it may not be input.

Fig 6 12 Typical I/O Signal Timing

6.4.8 Number of Input Reference Pulses and Motor Rotation Amount

The Servopack has input reference pulse multiplying function and PG output division and multiplying function.

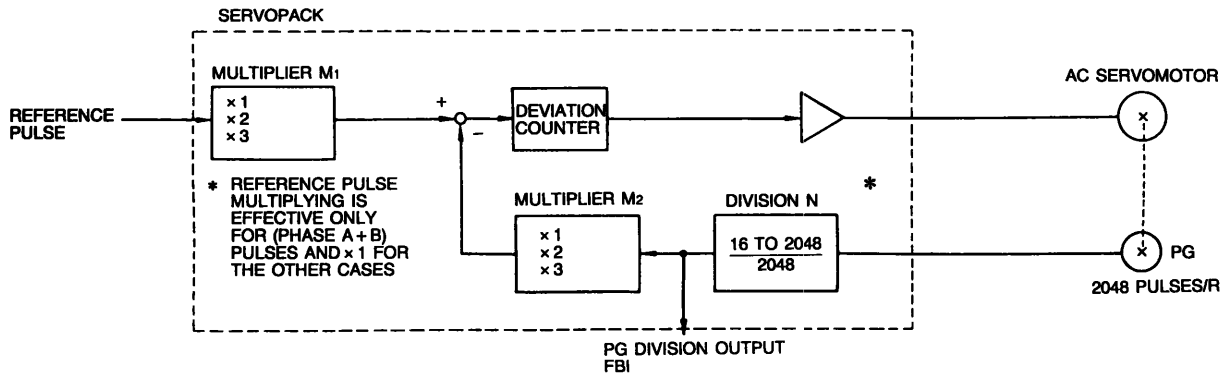

Fig 6 13 Servopack Pulse Processing Block Diagram

$$\text{Motor revolution (rev)} = \frac{\text{Reference pulse} \times M_1}{N \times M_2}$$

M1 : Value set by user constant Cn-02 bits 3, 4, 5

Three types : × 1, × 2, × 4

M2 : Value set by user constant Cn-02 bits 8, 9

Three types : × 1, × 2, × 4

N : Value set by user constant Cn-0A

Set value : 16 to 2048

Note : When 2048 cannot be divided by division set value N without the remainder, two types [differing by $1/2048 \times 4$ (rev)] of the 1 pulse width of feedback pulse after division output occur. Therefore, two types of the positioning width are also generated.

6.5 PROTECTIVE FUNCTIONS

DR1 SERVOPACK provides functions to protect the body and motor from malfunctions.

6.5.1 Dynamic Brake Function

DR1 SERVOPACK incorporates a dynamic brake for emergency stop. This brake operates when :

- Alarm (fault detection) occurs.
- Servo OFF command is opened.
- Power supply is turned OFF.
- Overtravel (P/N-OT) occurs.

Normally, this dynamic brake is not applied while the motor stops, but can be made operational by setting user constant.

6.5.2 Error Detection Functions

Table 6.6 lists trouble detection functions of the DR1 SERVOPACK. Type of alarm is identified by a combination of three forms of outputs.

Table 6 3 Error Detection Functions

○ Output transistor ON
× . Output transistor OFF

Digital Operator Type JUSP-OP02A	Output Form				ALM Output	Fault Detecting Function	Detection Contents
	AC Servo LED Display	Fault Output Code					
		ALO1	ALO2	ALO3			
A.0 [*]	0.	×	×	×	×	Parameter Fault	Parameter fault
A.10	1.	○	×	×	×	Overcurrent	<ul style="list-style-type: none"> • Overcurrent flow in main circuit • Overheat heat sink of SERVOPACK
A.20	2.	×	○	×	×	Fuse Blown	Fuse blown
A.30	3.	○	○	×	×	Regenerative Fault	Regenerative circuit not activated in SERVOPACK (200W or more for 200V, 100W or more for 200V)
A.31	3.	○	○	×	×	Overflow	Deviation counter lag pulse number exceeds the set value
A.40	4.	×	×	○	×	Overvoltage	Excessively high DC voltage in the main circuit [approx 420V (210V for 100V)]
A5 [*]	5.	○	×	○	×	Overspeed	<ul style="list-style-type: none"> • Motor speed exceeds the maximum r/min • Speed reference voltage exceeding the maximum r/min is input
A60	6.	×	○	○	×	Undervoltage	Excessively low DC voltage in the main circuit after power supply is turned on [approx 150V (75V for 100V)]
A.7 [*]	7.	○	○	○	×	Overload	Overload conditions of motor and SERVOPACK
A.b2	b.	×	×	×	×	Reference Input Read-in Error	Element error on the printed circuit board of SERVOPACK
A.C [*]	c.	○	×	○	×	Overrun	Wrong wiring of motor circuit or PG signal line
CPFD 1	1.	×	×	×	×	CPU Error	Any error of CPU
A.99		×	×	×	○	This is not an alarm	

6.5.3 Servo Alarm Output (ALM+, ALM–)



If any of the trouble detection functions listed in Par. 6.5.2 is activated, the power drive circuit in the DR1 SERVOPACK is turned OFF, 7-segment LEDs indicate the operation condition and a servo alarm signal is output. An alarm code is also output to external equipment through open collector output circuits ALO1 to ALO3. For the alarm codes, see Table 6.3.

6.5.4 Protective Circuit Operation

An alarm signal indicates some trouble. Check the cause and correct the trouble, and restart the operation. Before checking the case, turn OFF the power to the main circuit to avoid danger. Apply the sequence so that the alarm signal turns OFF only the main circuit (ⓑ, ⓓ), as shown in Fig. 6.1 and 6.2 allows rapid reaction in the event of a malfunction. If the control power supply (ⓐ, ⓔ) is turned OFF at that time, the light emitting diode (LED) in the SERVOPACK displaying the cause of alarm signal output is also extinguished.

However, the information on the faults which occurred can be checked by the fault traceback mode function of the digital operator (JUSP-OP02A).





6.5.5 Resetting Servo Alarm

To reset a servo alarm, input the alarm reset signal or turn OFF power. However, an alarm at  or  lighting (SERVOPACK overload) cannot be released soon. Two minutes or more is needed before resetting. When used in the position control mode, the positional deviation counter operates even at alarm occurrence. Therefore, when the alarm is released, set “H” to the clear input signal or turn OFF the control power supply to clear the lag pulses in the positional deviation counter without fail.

6.6 DISPLAY

By using the  LED and 7-segment LEDs, the Servopack status and alarms are displayed.

Table 6 4 Status Indication

SERVOPACK Status	Indication
Control power supply being applied	Some displayed in 7-segment LEDs (lighting)
Main power supply being applied	LED  lights
Baseblocking	7-segment LED 
Current under conduction	7-segment LED 
P-side overtraveling	7-segment LED 
N-side overtraveling	7-segment LED 

Note For the alarm indication, refer to Par. 6 5.2 “Error Detection Functions.”

6.7 PRECAUTIONS FOR APPLICATION

6.7.1 Overheating Loads

The motor is rotated by the load ; it is impossible to apply brake (regenerative brake) against this rotation and achieve continuous running.

Example : Driving a motor to lower objects (with no counterweight)

Since DR1 SERVOPACK has short time regenerative brake capability (corresponding to the motor stopping time), for application to a overhanging loads, contact your Yaskawa representative.

6.7.2 Load Inertia J_L

The allowable load inertia J_L converted to the motor shaft must be within 30 times the inertia of the applicable AC SERVOMOTOR. If the allowable inertia is exceeded, an overvoltage alarm may be occurred during deceleration. If this occurs, take one or more of the following actions :

- Reduce the current limit.
- Slow down the deceleration curve.
- Decrease the maximum rotating speed.

For details, contact your Yaskawa representative.

6.7.3 High Voltage Line

If the supply voltage is 400/440V, the voltage must be dropped to 200V or 100V using a power transformer. Table 6.9 shows the transformer selection.

6.8 PRECAUTIONS OF OPERATION

6.8.1 Noise Control

DR1 SERVOPACK uses high-speed switching, elements in the main circuit. When these high-speed switching elements are switched, the effect of $\frac{di}{dt}$ or $\frac{dv}{dt}$ (switching noise) may sometimes occur depending on the wiring or grounding method.

DR1 SERVOPACK incorporates a CPU. This requires wiring and provision to prevent noise interference. To reduce switching noise as much as possible, the recommended method of wiring and grounding is shown in Fig. 6.20.

(1) Grounding Method

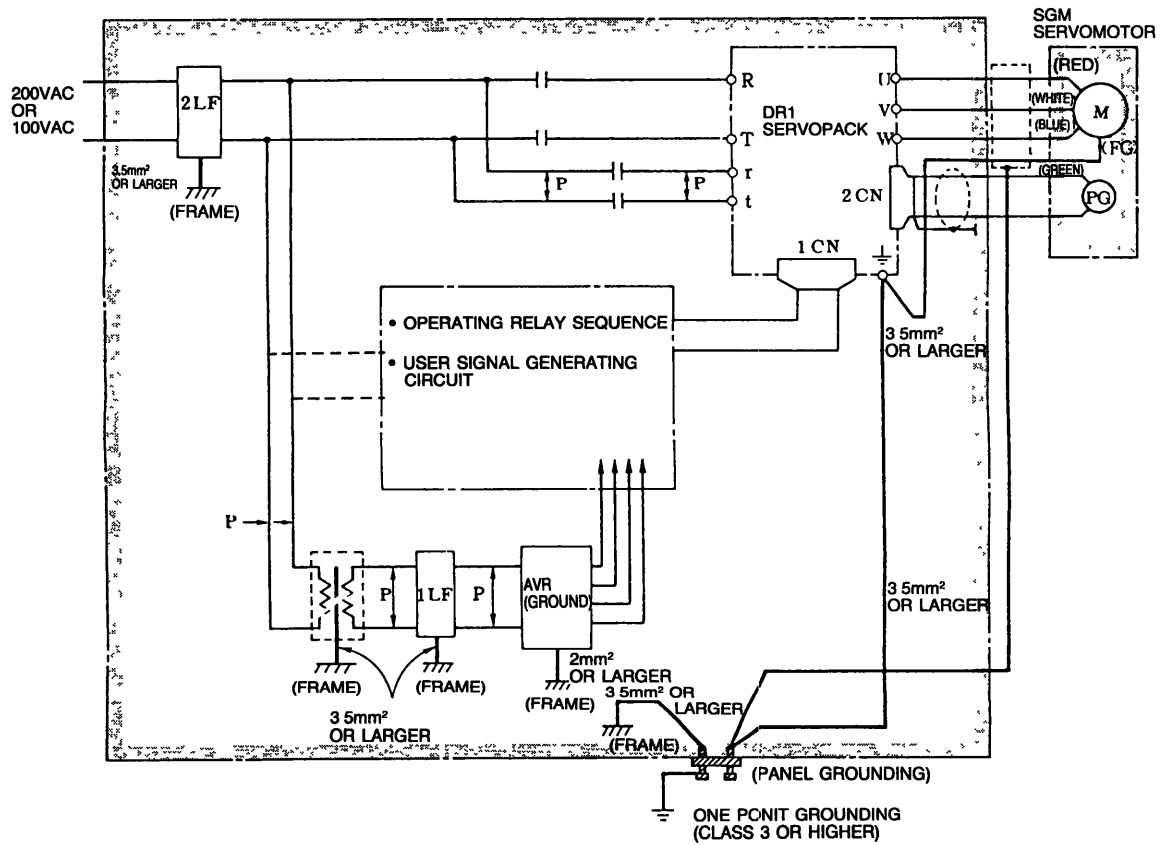

\overline{P} · Twisted pair wires

Notes ·

- 1 Use wires of 3.5 mm² or larger for grounding to the case (preferably flat-woven copper wire).
- 2 Connect line filters observing the precautions as shown in (2), "Noise filter installation"

Fig 6.20 Grounding Method

- Motor frame grounding

When the motor is at the machine side and grounded through the frame, $C_f \frac{dv}{dt}$ current flows from the PWM power through the stress capacitance of the motor. To prevent this effect of current, motor ground terminal FG (motor frame) should be connected to terminal \oplus of DR1 SERVOPACK. (Terminal \ominus of DR1 SERVOPACK should be directly grounded.)

- DR1 SERVOPACK SG 0V

Noise may remain in the input signal line, so make sure to ground SG 0V. When motor wiring is contained in metal conduits, the conduits and boxes must be grounded. The above grounding uses one-point grounding.



(2) Noise Filter Installation

When noise filters are installed to prevent noise from the power line, the block type must be used. The recommended noise filters are shown in Table 6.5. The power supply to peripherals also needs noise filters.

NOTE

If the noise filter connection is wrong, the effect decreases greatly. Observing the precautions, carefully connect them as shown in Figs. 6.15 to 6.18.

Table 6.8 Recommended Noise Filter

Class	DR1 SERVOPACK Type		Applicable Noise Filter	Recommended Noise Filter*	
				Type	Specifications
200 VAC	30 W (0.04 HP)	DR1-A3AC	 Good	LF-205A	Single-phase 200 VAC class, 5 A
	50 W (0.07 HP)	DR1-A5AC			
	100 W (0.13 HP)	DR1-01AC			
	200 W (0.27 HP)	DR1-02AC		LF-210	Single-phase 200 VAC class, 10 A
	400 W (0.53 HP)	DR1-04AC		LF-220	Single-phase 200 VAC class, 20 A
	750 W (1.01 HP)	DR1-08AC			
100 VAC	30 W (0.04 HP)	DR1-A3BC	 Poor	LF-205A	Single-phase 200 VAC class, 5 A
	50 W (0.07 HP)	DR1-A5BC			
	100 W (0.13 HP)	DR1-01BC		LF-210	Single-phase 200 VAC class, 10 A
	200 W (0.27 HP)	DR1-02BC			

* Made by Tokin Corp.

6.8.1 Noise Control (Cont'd)

- (a) Separate the input and output leads.
Do not bundle or run them in the same duct.

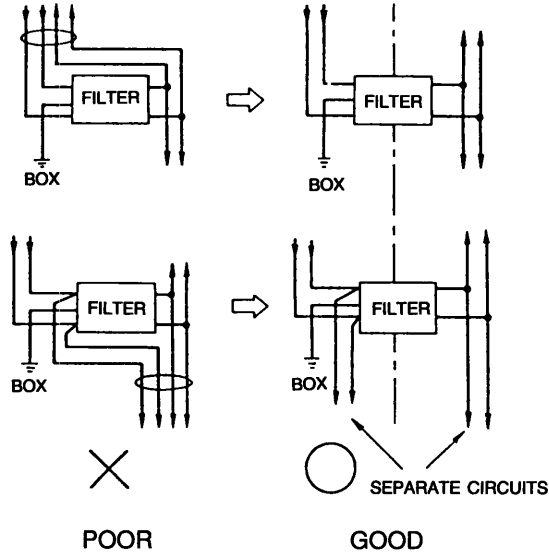

Fig 6 21

- (b) Do not bundle the ground lead with the filter output line or other signal lines or run them in the same duct.

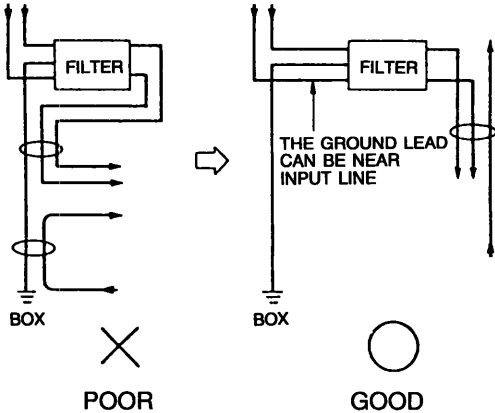

Fig 6 22

- (c) Connect the ground lead singly to the box or the ground panel.

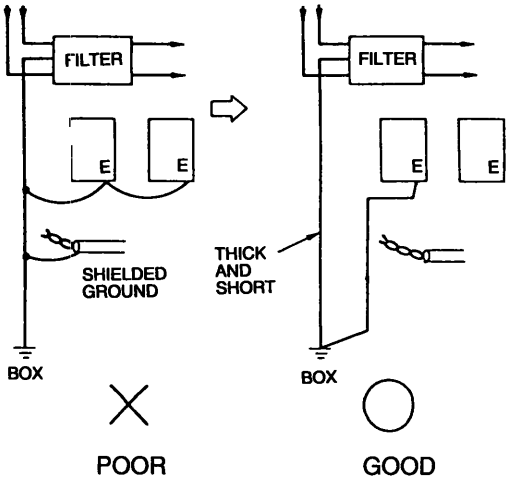

Fig 6 23

(d) If the control panel contains the filter, connect the filter ground and the equipment ground to the base of the control unit.

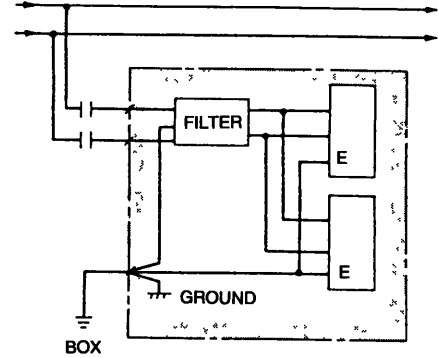

Fig 6 24

6.8.2 Power Line Protection

DR1 SERVOPACK is operated through the commercial power line (200 V or 100 V). To prevent power line accidents due to grounding error, contact error, or to protect the system from a fire, circuit breakers (MCCB) or fuses must be installed according to the number of DR1 SERVOPACKS used (Table 6.6).

A fast blow fuse cannot be used, because of the in-rush current.

Table 6 9 Power Supply Capacity and MCCB or Fuse Capacity

Class	DR1 SERVOPACK Type	Power Capacity Per DR1 SERVOPACK* kVA	Current Capacity per MCCB or Fuse† A
200 VAC	DR1-A3AC	0.25	5
	DR1-A5AC	0.3	
	DR1-01AC	0.5	
	DR1-02AC	0.75	
	DR1-04AC	1.2	9
	DR1-08AC	2.2	16
100 VAC	DR1-A3BC	0.2	5
	DR1-A5BC	0.3	
	DR1-01BC	0.5	
	DR1-02BC	0.75	8

* Values at rated load

† Operating characteristics (25°C) 200%/2s or more, 700%/0.01s or more

Note · Specify the high-speed type for installation of a leakage breaker (Time-delay type is not acceptable)

6.9 APPLICATION

6.9.1 Connection for Reverse Motor Running

If the machine construction requires that the normal forward rotation reference is used for reverse motor running and the normal reverse rotation reference for forward running, short circuit across terminals (2CN-1) and (2CN-7) on the PG connector (2CN).

In this case, other change of motor and PG connection is not required.

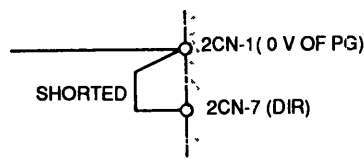

Fig 6 25

As for the divider outputs from the DR1 SERVOPACK, phase-B precedes phase-A by 90 degrees when forward rotation reference is input. Reverse rotation is also enabled by user constant Cn-02 bit-0 setting. After setting reverse rotation connection, it is necessary to turn OFF the control power supply once.

6.9.2 Motor Speed Measurement and Torque Reference

When an instrument is connected to measure speed and torque, make the connection as shown in Fig. 6.20, using a DC ammeter of $\pm 1\text{mA}$ (both swing).

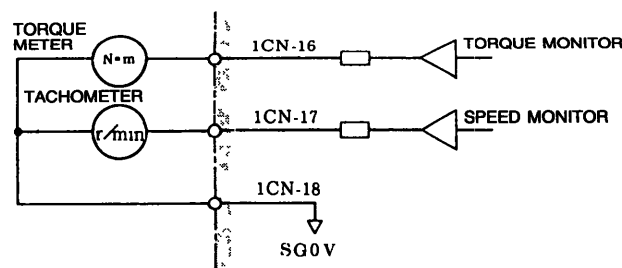

Fig 6 26

- Torque monitor output (1CN-16) : $\pm 0.5\text{V} \pm 10\%/100\%$ torque
- Speed monitor output (1CN-17) : $\pm 0.5\text{V} \pm 10\%/1000\text{r/min}$
- Instrument : $\pm 1\text{mA}$ (both swing) ammeter
Use ammeter of DCF-6 or DCF-12N or equivalent.

7. USER CONSTANTS

DR1 SERVOPACK supports the following user constants that can be set up and modified to fit the system.

Learn the meanings of these constants and use them. Use the digital operator to set up and modify them. (See Par.8, "DIGITAL OPERATOR.")

(1) Speed Reference Adjustment Gain : Cn-03 (INBGN)

- This constant is for adjusting motor speed reference. Possible adjustment range is from 0 to 2162 (r/min./V).
- Factory setting is rated speed/10V.

(2) Speed Loop Gain : Cn-04 (LOOPHZ)

- This is the proportional gain for the speed controller. Adjustment range is from 1 to 2000 (Hz).
- Factory setting is 80 (Hz).
- When motor is rotated as a single unit, set to 40 (Hz) or lower.

(3) Speed Loop Integration Time Constant : Cn-05 (PITIME)

- This is integration time for the speed controller. Adjustment range is from 2 to 10,000 (ms).
- Factory setting is 20 (ms).

(4) Emergency Stop Torque : Cn-06 (EMGTRQ)

- Set up braking torque for overtravel stop (a percentage of the motor is rated torque). Setting range is from 0% to the maximum torque. (100% = rated torque)
- It is possible to decelerate the motor at the set torque value, if the overtravel inputs P/N-OT are triggered (1CN-42, -43 set bit 8 of Cn-01).
- Factory setting is the maximum torque. (100% = rated torque)

(5) Soft Start Time : Cn-07 (SFSACC)

- This constant sets time required to accelerate from 0 r/min. to the maximum rotation speed and to decelerate from the maximum rotation speed to 0 r/min. Setting range is from 0 to 10,000 (ms).
- Factory setting is 0 (ms).
- If positioning control is to be performed, normally set the constant to 0 (ms).

(6) Forward Running Torque Limit : Cn-08 (TLMTF)

- This is torque limit of the motor in the forward running direction. Setting range is from 0 to the maximum torque (%).
- Factory setting is the maximum torque. (100% = rated torque)

(7) Reverse Running Torque Limit : Cn-09 (TLMTR)

- This is torque limit of the motor in the reverse running direction. Setting range is from 0 to the maximum torque. (100% = rated torque)
- Factory setting is the maximum torque. (100% = rated torque).

7. USER CONSTANTS (Cont'd)

(8) PG Dividing Ratio Setting : Cn-0A (PGRAT)

- Number of detected (phase-A and -B) pulses per rotation sent from the PG (optical encoder) is converted to the pulse number according to the setting of this constant and is output to 1CN-33 to -36.
- Set the number of output pulses per rotation. Setting range depends on the PG.
2048P/R: 16 to 2048 (integer)

(9) Zero-Speed Level : Cn-0B (TGONLV)

- This is motor zero-speed determination level. Setting range is from 1 to the maximum speed (r/min).
- When the motor rotation speed exceeds the set value, sequence output $\overline{\text{TGON}}$ is turned ON (between 1CN-27 and -28 are “closed”).
- Factory setting is 20 (r/min.).

(10) Mode Switches

- The following constants are used for setting mode switch operating points. Detection points where PI control is switched to P control are set for improving transient characteristic of acceleration, deceleration and output saturation of the speed controller. Different levels can be set for three types of detection points for the mode switch.

Torque reference (output from the speed controller) : Cn-0C (TRQMSW)

Speed reference : Cn-0D (REFMSW)

Detection of motor acceleration: Cn-0E (ACCMSW)

- The detection points can be selected by setting bits of user constant Cn-01.

(11) Zero-clamp Level : Cn-0F (ZCLVL)

- This is the motor rotation speed level at which zero-clamp is performed. Setting range is from 0 to the maximum speed (r/min).
- In the zero clamp speed control mode (set up by Cn-01 bits A=1, B=0), the $\overline{\text{P-CON}}$ speed reference is disconnected to clamp the motor rotating speed to zero when the motor rotating speed falls below this setting.

(12) Jog Speed : Cn-10 (JOGSPD)

- Set up jogging speed. Setting range is from 0 to the maximum speed (r/min).
- To start jogging, enter the operation reference from the digital operation.
- Factory setting is 100 (r/min.).

(13) Number of Encoder Pulse : Cn-11 (PULSNO)

- This is the number of pulses per rotation of the motor encoder.
- Do not change the preset value.

(14) Delay Time from Brake Interlock Reference Output to SVOFF Operation : Cn-12 (BRKTIM)

- Outputs the brake interlock signal from $\overline{\text{TGON}}$ output by Cn-01 bit No. E = 1.
- This is delay time from the output of brake reference to the actuation of SVOFF for a motor with a brake. Setting range is from 0 ms to 500 ms, in increments of 10ms.
- For details of Cn-12 (BRKTIM), Cn-15 (BRKSPD) and Cn-16 (BRKWAI), see Par. 5.6.2 “Holding Brake Interlock Signal”.

(15) Selection of Sequence Inputs, Reference Signal Error Stop Methods, Control Modes, and Mode Switches

Use user constant Cn-01 memory switches for the above selections. (For the assignment and explanation of the memory switches, see Table 7.2, “User Constant Cn-01 List.”)

See sequences (1), (2) and select an error stop method fit for the system.

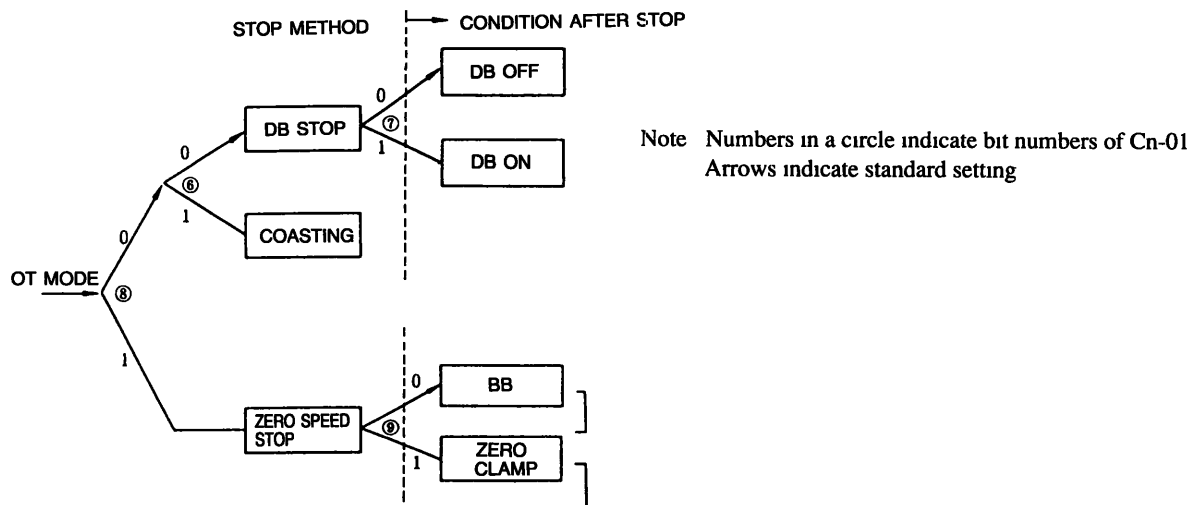

(a) Sequence on OT mode

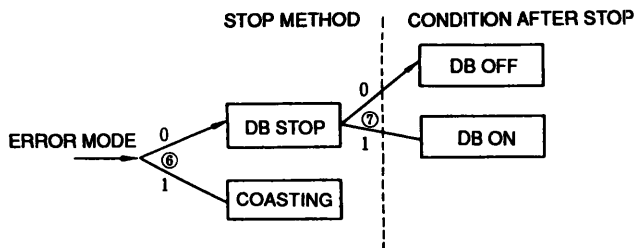

(b) Sequence on fault mode (except OT mode)

Fig 7.1 Error Stop Sequences

7. USER CONSTANTS (Cont'd)

(16) Forward Rotation External Current Limit : Cn-18 (CLMIF)

This is motor current limit in the forward rotation direction. This limit is effective when contact input $\overline{P-CL}$ (1CN-45) is ON. Setting range is from 0 to the maximum torque. (100% = rated torque) Factory setting is 100 (%).

(17) Reverse Rotation External Current Limit : Cn-19 (CLMIR)

This is motor current limit in the reverse rotation direction. This limit is effective when contact input $\overline{N-CL}$ (1CN-46) is ON. Setting range is from 0 to the maximum torque. (100% = rated torque) Factory setting is 100 (%).

(18) Position Loop Gain : Cn-1A (POSGN)

This is position controller proportional gain. The adjustable range is from 1 to 500 (1/s). Factory setting is 40 (1/s).

(19) Bias : Cn-1C (BIASLV)

This is position controller bias setting. Used according to the load condition in order to reduce the positioning time. The adjustable range is from 0 to 450 (r/min). Factory setting is 0 (r/min).

(20) Forward Feed : Cn-1D (FFGN)

This is position controller forward feed compensation. The adjustable range is from 0 to 100 (%). Factory setting is 0 (%).

(21) Positioning Completion Width : Cn-1B (COINLV)

Sets the positioning completion signal output (COIN) width. Setting range is 0 to 100 (pulses). Factory setting is 7 (pulses).

(22) Overflow : Cn-1E (OVERLV)

Sets the overflow detection level of position deviation. Setting range is 1 to 10,000 ($\times 100$ pulses). Factory setting is 10,000 ($\times 100$ pulses).

(23) Internal Set

The following constants are used to enter a mode where speed control is performed according to contact inputs $\overline{P-CL}$ and $\overline{N-CL}$ (1CN-45, -46).

Three speeds are programmed.

Corresponding user constants are shown below.

1st speed : Cn-1F (SPEED1)

2nd speed : Cn-20 (SPEED2)

3rd speed : Cn-21 (SPEED3)

Setting range of each constant is from 0 to the maximum speed (r/min). Factory setting is 100 for the first speed, 200 for the second, and 300 for the third.

Table 7 3 User Constants Cn-03 through Cn-21 (Constant Setting) List

	User Constant	Symbol	Name	Unit	Lower Limit	Upper Limit	Setting Prior to Shipment	Remarks
Gain Constants	Cn-03	INBGN	Speed Reference Adjustment Gain	(r/min) / V	10	2162	300	Rated Speed/10V
	Cn-04	LOOPHZ	Speed Loop Gain	Hz	1	2000	80	*
	Cn-05	PITIME	Speed Loop Integration Time	ms	2	10000	20	
Torque Constants	Cn-06	EMGTRQ	Emergency Stop Torque	%	0	Max Torque	Max Torque	OT Mode
	Cn-08	TLMTF	Forward Running Torque Limit	%	0	Max Torque	Max Torque	
	Cn-09	TLMTR	Reverse Running Torque Limit	%	0	Max Torque	Max Torque	
	Cn-13	TCRFGN	Torque Reference Gain	$\frac{1}{10} V /$ Rated Torque	10	100	30	
	Cn-14	TCRLMT	Speed Limit with Torque Control I	r/min	0	Max Speed	Max Speed	
	Cn-17	TRQFIL	Torque Reference Filter Time	100 μ s	0	250	4	
	Cn-18	CLMIF	Forward External Current Limit	%	0	Max Torque	100	
	Cn-19	CLMIR	Reverse External Current Limit	%	0	Max Torque	100	
Sequence Constants	Cn-07	SFSACC	Soft Start Time (Acceleration)	ms	0	10000	0	
	Cn-0B	TGONLV	Zero-speed Level	r/min	1	Max Speed	20	
	Cn-0F	ZCLVL	Zero-clamp Level	r/min	0	Max Speed	10	
	Cn-12	BRKTIM	Delay Time from Braking Reference to SVOFF	10 ms	0	50	20	

Note · 100% = rated torque

* Factory setting of Cn-04 (speed loop gain) is determined by the following conditions : Load inertia \leq motor inertia $\times 3$
Be sure to set the value of Cn-04 to -40 or less when motor is rotated without load. If the value has been kept at the factory setting, the motor may oscillate.

7. USER CONSTANTS (Cont'd)

Table 7 3 User Constants Cn-03 through Cn-21 (Constant Setting) List (Cont'd)

	User Constant	Symbol	Name	Unit	Lower Limit	Upper Limit	Setting Prior to Shipment	Remarks
Sequence Constants	Cn-15	BRKSPD	Brake Timing at Motor Rotation (Speed level at which brake reference is output)	r/min	0	Max Speed	100	
	Cn-16	BRKWAI	Brake Timing at Motor Rotation (Waiting time from SVOFF to brake reference output)	10ms	10	100	50	
Encoder Pulse Constants	Cn-0A	PGRAT	PG Dividing Ratio	P/R	16	Encoder Number of pulses 2048	Encoder Number of pulses 2048	†
	Cn-11	PULSNO	Number of Encoder Pulses	P/R	—	—	Encoder Number of pulses 2048	
Other Constants	Cn-0C	TRQMSW	Mode Switch (Torque Reference)	%	0	Max Torque	200	
	Cn-0D	REFMSW	Mode Switch (Speed Reference) ‡	r/min	0	Max Speed	0	
	Cn-0E	ACCMSW	Mode Switch (Motor Acceleration Detection)	10 (r/min) /s	0	3000	0	
	Cn-10	JOGSPD	JOG Speed	r/min	0	Max Speed	100	
Gain constants	Cn-1A	POSGN	Position Loop Gain	1/s	1	500	40	
	Cn-1C	BIASLV	Bias	r/min	0	450	0	
	Cn-1D	FFGN	Forward Feed	%	0	100	0	
Other Constants.	Cn-1B	COINLV	Positioning Completion Width	pulse	0	100	7	
	Cn-1E	OVERLV	Overflow	×100 pulse	1	10000	10000	
	Cn-1F	SPEED1	1st Speed	r/min	0	Max Speed	100	
	Cn-20	SPEED2	2nd Speed	r/min	0	Max Speed	200	
	Cn-21	SPEED3	3rd Speed	r/min	0	Max Speed	300	

Note 100% = rated torque

† After modifying Cn-0A (PG division ratio setting), turn OFF power and start up again The modified value takes effect only after restarting

‡ In the position control mode, the constant is set by the lag pulses
Setting range 0 to 4950 (pulse)

Table 7 4 User Constant Cn-01 (Memory Switch) List

Selection	Bit No	Setting	Conditions	Standard
Sequence Input Selection	0	0	Servo ON/OFF by external input ($\overline{SV-ON}$)	0
		1	The servo is ON at all times	
	1 (No-used)	0		0
		1		
	2	0	The P-OT signal prohibits forward running	0
		1	Forward running is permitted at all times	
	3	0	The N-OT signal prohibits reverse running	0
		1	Reverse running is permitted at all times	
Input Signal Selection	4	0	The IN-A input is used	0
		1	Regardless of the IN-A input presence, the SERVOPACK concludes that the IN-A input is 0	
	5	0	The IN-B input is used	0
		1	Regardless of the IN-B input presence, the SERVOPACK concludes that the IN-B input is 0	
Fault Stop Selection	6	0	<DB stop> The dynamic brake stops the motor	0
		1	<Coasting to a stop> The motor is freed and brought to a stop	
	7	0	<DB OFF after DB stop> The dynamic brake is turned OFF after the motor is stopped	1
		1	<DB continuously ON after DB stop> The dynamic brake remains activated after the motor is stopped	
	8*	0	The overtravel status stop method coincides with bit 6	0
		1	<Overtravel zero speed stop> In the overtravel status, the motor is stopped at the torque setting defined by user constant Cn-06	
	9†	0	In the overtravel status, base blocking (B3) is implemented after the motor stops	0
		1	In the overtravel status, zero clamping is effected after zero speed stop	
Mode Switch Selection	DC‡	00	<Torque reference> Based on the torque reference level defined by user constant Cn-0C	00
		01	<Speed reference> Based on the speed reference level defined by user constant Cn-0D	
		10	<Acceleration> Based on the acceleration level defined by user constant Cn-0E #	
		11	<None> The mode switch function is not provided	
Presence of External Brake	E	0	The braking command function is not provided	0
		1	The braking command function is provided	
—	F			0

* The fault stop method in the torque control mode complies with bit 6

† Selects the status based on the stop method selected for the overtravel status (bit 8)

‡ Selects the mode switch operating condition When the mode switch operates, the speed control mode changes from PI control to P control (Effective only for speed control)

In the position control mode, the reference is based on the lag pulses set by user constant Cn-0D.

7. USER CONSTANTS (Cont'd)

Table 7.4 User Constant Cn-01 (Memory Switch) List (Cont'd)

Selection	Bit No	Setting	Description	Reference Input	Sequence Signal Input	Standard
Control Mode Selection	B A	0 0	<p><Speed control></p> <ul style="list-style-type: none"> Regular speed control The P-CON signal (1CN-41) is used to effect P/PI control changeover 	Speed reference (IN-A) Auxiliary reference input (IN-B)	P-CON OFF PI control ON P control	0 0
		0 1	<p><Zero clamp speed control></p> <ul style="list-style-type: none"> After the motor is stopped (ZCLVL), the speed reference is disconnected to execute the zero speed stop function The P-CON signal (1CN-41) is used to turn the zero clamp function ON and OFF 		P-CON OFF Zero clamp function OFF ON Zero clamp function ON	
		1 0	<p><Torque control I></p> <ul style="list-style-type: none"> The motor output torque is controlled by the torque reference (IN-A) The IN-B cannot be used 	Torque reference (IN-A)	None	
		1 1	<p><Torque control II ></p> <ul style="list-style-type: none"> The P-CON signal (1CN-41) is used for torque/speed control mode changeover <p>At torque control</p> <ul style="list-style-type: none"> The motor output torque is controlled by the torque reference (IN-B) The speed limit can be entered from outside (IN-A) <p>The IN-A voltage (+) limits both the forward and reverse running speeds</p> <p>[MOTOR SPEED]</p>  <p>At speed control</p> <ul style="list-style-type: none"> The speed reference is entered from the IN-A The IN-B cannot be used 	<p>At torque control</p> <p>Torque reference (IN-B) Speed reference (IN-A)</p> <p>At speed control</p> <p>Speed reference (IN-A)</p> <p>Notes</p> <ul style="list-style-type: none"> If speed goes beyond the limit negative feedback of torque in proportion to speed difference from limit speed occurs to restore moderate speed Therefore, width of actual motor rotation speed limit depends on load conditions In case of continuous regeneration (tension control), Contact your Yaskawa representative 	P-CON OFF Torque control ON Speed control	

Table 7 5 User Constant Cn-02 (Memory Switch) List

Selection	Bit No	Setting	Description	Standard
Reverse Rotation Mode	0	0	CCW Forward running	0
		1	CW Forward running	
Not-used	1			0
Contact Reference Mode	2	0	Contact inputs $\overline{P-CL}$ and $\overline{N-CL}$ are used as power supply limit	0
		1	Contact inputs $\overline{P-CL}$ and $\overline{N-CL}$ are used as speed input reference selection (1st to 3rd speed) signals	
Reference Pulse Mode	3, 4, 5	000	Sign + Pulse	000
		100	CW + CCW	
		010	Phase-A + Phase-B (×1)	
		110	Phase-A + Phase-B (×2)	
		001	Phase-A + Phase-B (×4)	
Monitor Change (TRQ-M)	6	0	Torque monitor 0 5V/100%	0
		1	Speed reference monitor 0 5V/1000 r/min	
Monitor Change (VTG-M)	7	0	Speed monitor 0 5V/1000 r/min	0
		1	Lag pulse monitor 3V/100 pulse	
FB Pulse Multiplier	8, 9	00	×1	00
		01	×2	
		10	×2	
		11	×4	
Deviation Counter Clear	A	0	Solid	0
		1	Differential	
Speed/Position Control Change	B	0	Speed (or torque) control mode is set	0
		1	Position control mode is set	
Overflow Alarm	C	0	Cn-1E setting value overflow alarm	0
		1	2 ¹⁸ overflow alarm	
Reference Pulse Reverse Operation	D	0	Normal operation	0
		1	Reverse operation	
Monitor Output Level Change	E	0	Lag pulse monitor output level 3V/100 pulses	0
		1	Lag pulse monitor output level 3V/10000 pulses	
Reference Pulse Filter	F	0	Filter is not provided	0
		1	Filter is provided	

Note Turn OFF the power supply after setting

8. DIGITAL OPERATOR (TYPE : JUSP-OP02A)

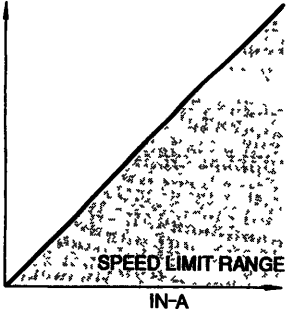
8.1 SWITCH OPERATION

Fig. 8.1 shows the digital operator. The digital operator has various functions as listed by modes in Par. 8.2, "DIGITAL OPERATOR FUNCTION."

Notes :

1. The digital operator's constant setup data is retained even after the power is turned OFF.
2. Even if the power is turned OFF after fault occurrence, the fault data is retained in memory. Therefore, it is possible to check the fault data after the power is turned back ON.
3. The monitor mode can be changed even during operations.



592 28

Fig 8.1 Digital Operator (Hand-held Type)

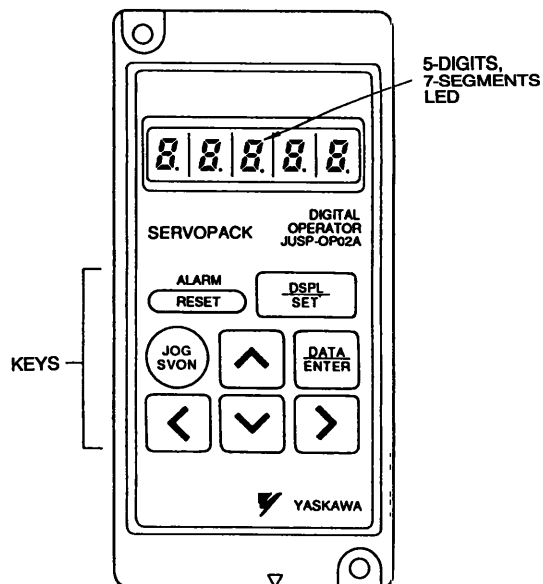

8.2 DIGITAL OPERATOR FUNCTIONS

Table 8.1 shows the digital operators functions. The status display is the default when control power is turned ON. To change the mode, use  key as shown in Fig. 8.2.

Table 8 1 Digital Operator Functions

Mode	Function
Status Indication Mode	Various Status Indications <ul style="list-style-type: none"> • Base Block • On Operation • Fault (See Par 8 3)
Setting Mode	Refer to "User Constant Setting " (See Par 8 4 1) <ul style="list-style-type: none"> • Operation (JOG) from digital operator (See Par 8 4 3) • Operation check enabled by single-unit of DR1 SERVOPACK or motor without external sequence (See Par 8 4 4) • Speed Reference Offset Adjustment (See Par 8 4 5)
Monitor Mode	Various Monitoring <ul style="list-style-type: none"> • Speed • Speed Reference • Torque Reference • Number of Pulses from Origin (Phase-U) • Electrical Angle • Interior Status Bit (See Par 8 5)
Fault Traceback Indication Mode	Fault History (See Par 8 6)

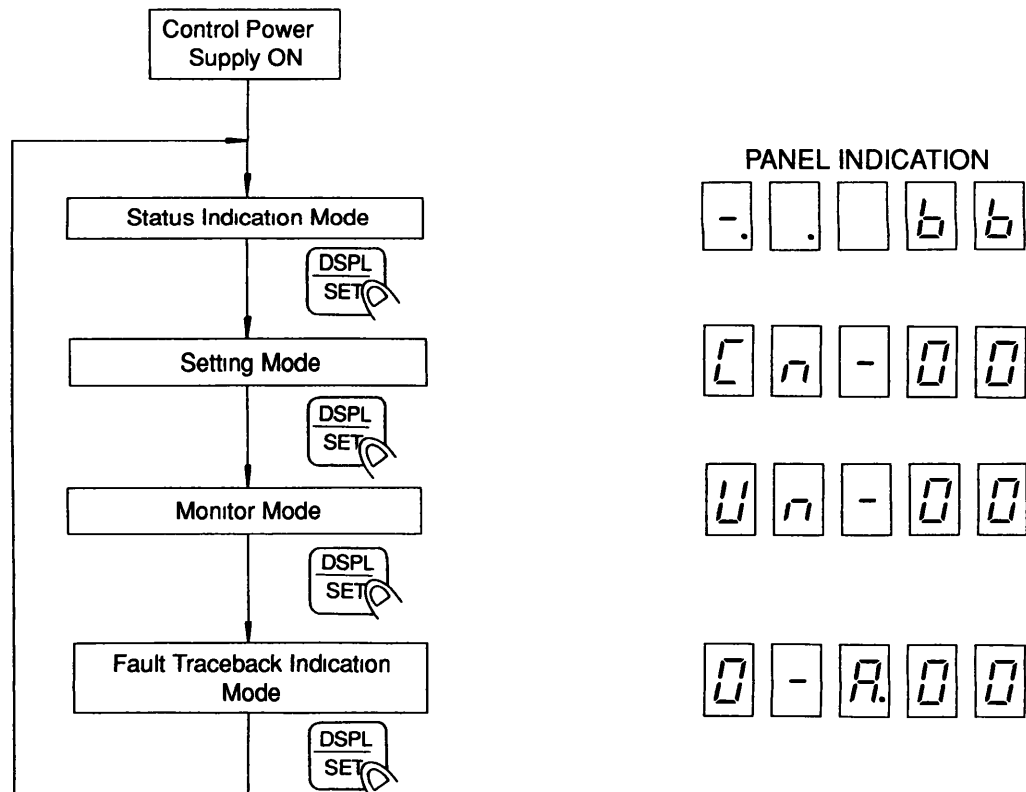

Fig 8.2 Mode Changeover

8.3 STATUS INDICATION MODE

When this mode is selected, the condition of SERVOPACK is indicated with bits and codes as shown in Fig. 8.3. Table 8.2 shows the bit data contents. Table 8.3 shows the codes and conditions.

- ALARM
RESET : Alarm reset switch

- DSPL
SET : Changes status indication mode into setting mode.

Panel Display

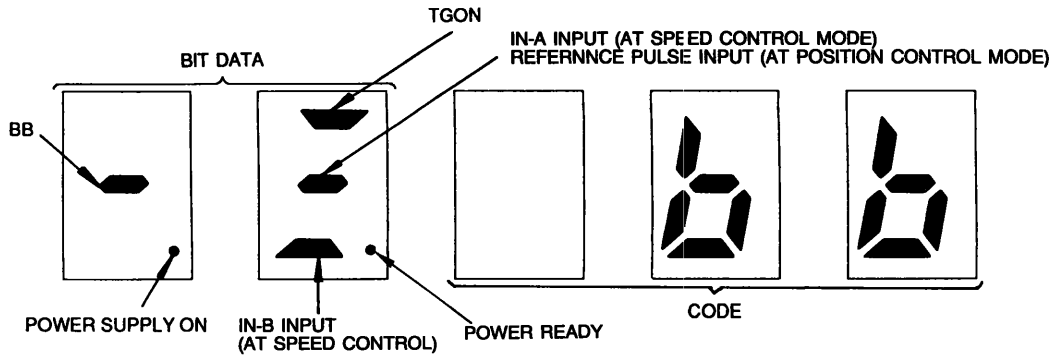

Fig 8.3 Status Indication Mode

Table 8.2 Bit Data Contents

Bit Data	Contents
Power Supply ON	Light goes ON at power supply ON
BB	Light goes ON at base block, and goes OFF at servo ON
TGON	Light goes ON at motor rotating speed higher than TGON level (Standard setting is 20 r/min)
IN-A Input	Light goes ON at IN-A input equal to or higher than TGON level (in speed control mode)
Reference Pulse Input	Light goes ON at reference pulse input (in position control mode)
IN-B Input	Light goes ON at IN-B input equal to or higher than TGON level (only in speed control)
Power Ready	Light goes ON at main power supply ON

Table 8.3 Codes and Status

Code	Status
<i>bb</i>	Base Block
<i>run</i>	On Operation
<i>pot</i>	Forward Running prohibited
<i>not</i>	Reverse Running prohibited
<i>A00</i>	Alarm Status Refer to Table 8.6
<i>A02</i>	
}	

8.4 SETTING MODE

In this mode, the following operations can be performed.

- User constant setup and monitor
- Jog operations from the digital operator
- Offset adjustment
- Fault traceback data clearing
- Check of motor parameters

8.4.1 User Constant (Data) Setup and Monitor (Cn-03 to Cn-21)

Panel Display

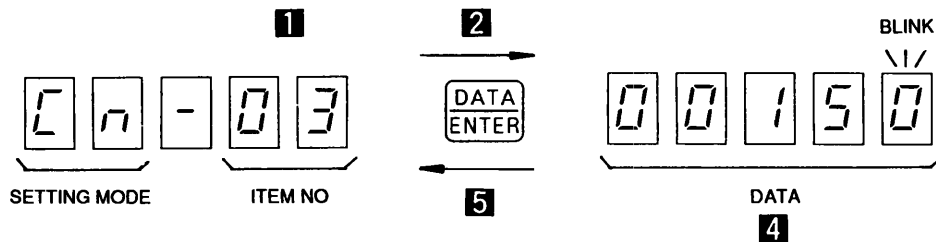

















Fig 8 4 User Constant Setting

- Set up the item number with the , , , or  key.
 - With the  or  key, choose a setup digit. The chosen digit starts blinking to indicate that its numerical value can be changed.
 - With the  or  key, increase or decrease the numerical value until the desired value is obtained.
- With the  key, display the data related to the selected item number.
- With the , , , or  key, set up the data. (The same operation as stated in 1.)
- Retain the data with the  key.
- With the  key, return to the item No. display status.
- Repeat steps 1 through 5 as needed.
- Using the  key, switch from the setting mode to the monitor mode.

8.4.2 User Constant (Memory Switch) Setup and Monitor (Cn-01 and Cn-02)

User constants Cn-01 and Cn-02 can be set up or monitored as memory switch bits. The procedures for item number setup and data display are the same as indicated in Par. 8.4.1 **1** and **2**.

Panel Display

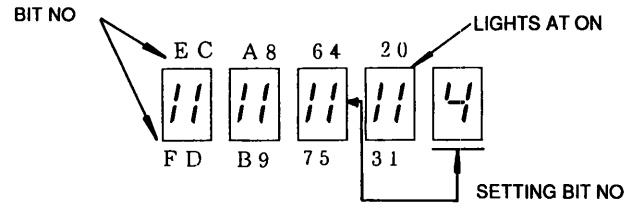

Fig 8 5 Bit Date Display









- 1** With the  or  key, enter the setup memory switch bit No. at the far right end of the panel.
- 2** With the  key, set the memory switch to ON or OFF (either  or  can be used). The panel indication comes on when the switch is ON, and goes off when the switch is OFF.
- 3** Repeat steps **1** and **2** as needed.
- 4** Retain the data with the  key.
- 5** With the  key, return to the item No. display status.
- 6** Using the  key, switch from the setting mode to the monitor mode.

Table 7.2 shows memory switches of user constant Cn-01, and Table 7.3 those of user constant Cn-02.

8.4.3 Digital Operator Controlled Operation Mode Selection and Operating Procedure

(1) Digital Operator Controlled Operation Mode Selection

When user constant Cn-00 is set to 00, the operations are to be controlled from the digital operator.

Panel Display

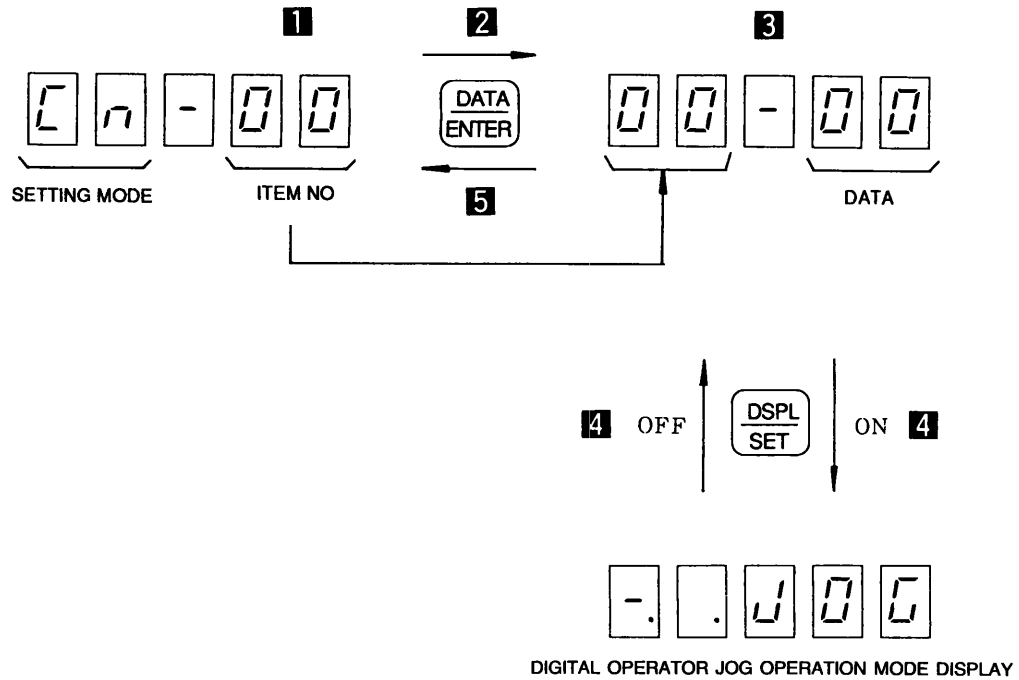

















Fig. 8 6 Digital Operator Jog Operation Mode

- 1 Select the item number 00 with the  ,  ,  or  key.
- 2 With the  key, display the data related to the selected item number.
- 3 With the  ,  ,  or  key, select the number 00.
- 4 With the  key, turn ON or OFF the monitor panel jog operation mode.
- 5 With the  key, return to the item No. display status.
- 6 Using the  key, switch from the setting mode to the monitor mode.

(2) Digital Operator Jog Operation Procedure

For speed reference adjustment, use user constant Cn-10 (see Table 7.3).

- 1 With the  switch, effect SVON/SVOFF changeover.
- 2 The motor runs in the forward direction while the  key is held down.
- 3 The motor runs in the reverse direction while the  key is held down.

8.4.4 Speed Reference Offset Adjustment

When user constant Cn-00 is set to 01, the system enters the speed reference offset adjustment mode.

Panel Display

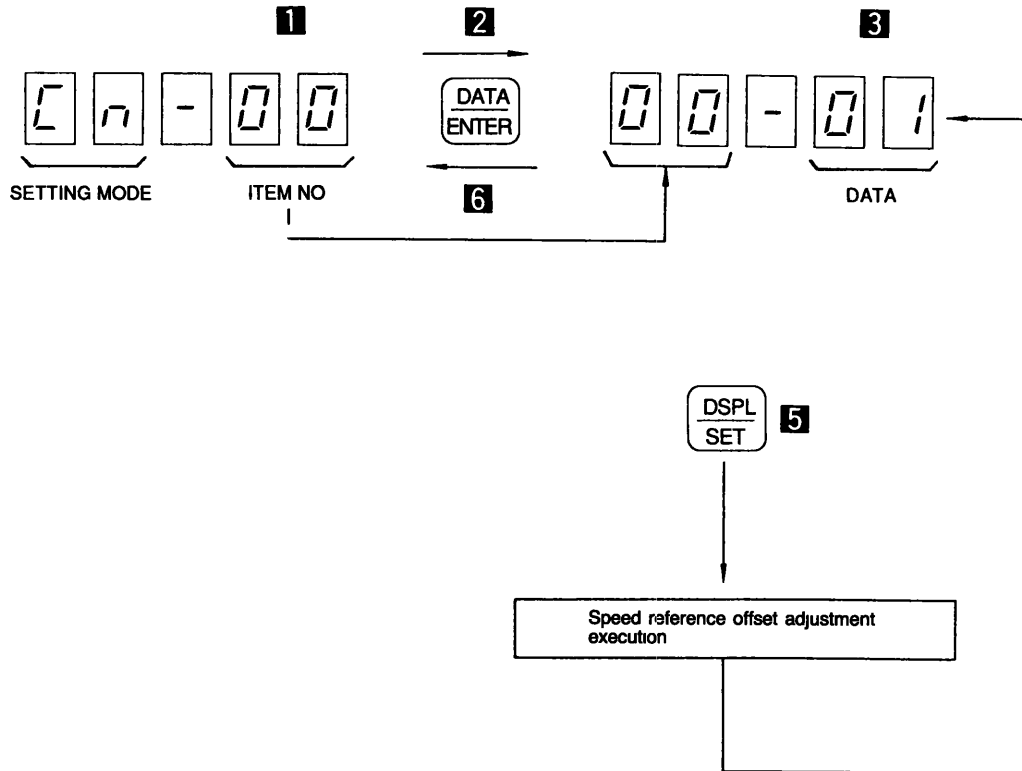













Fig 8 7 Speed Reference Offset Adjustment

- 1 Select the item number 00 with the  ,  ,  or  key.
- 2 With the  key, display the data related to the selected item number.
- 3 With the  ,  ,  or  key, select the number 01.
- 4 Apply the desired zero speed reference voltage with speed reference input IN-A and IN-B.
- 5 With the  key, make speed reference offset adjustment and return to the user constant Cn-00 data display status.
- 6 With the  key, return to the item No. display status.
- 7 Using the  key, switch from the setting mode to the monitor mode.

8.4.5 Clearing Fault Traceback Data

When user constant Cn-00 is set to 02, fault traceback data are cleared.

Panel Display

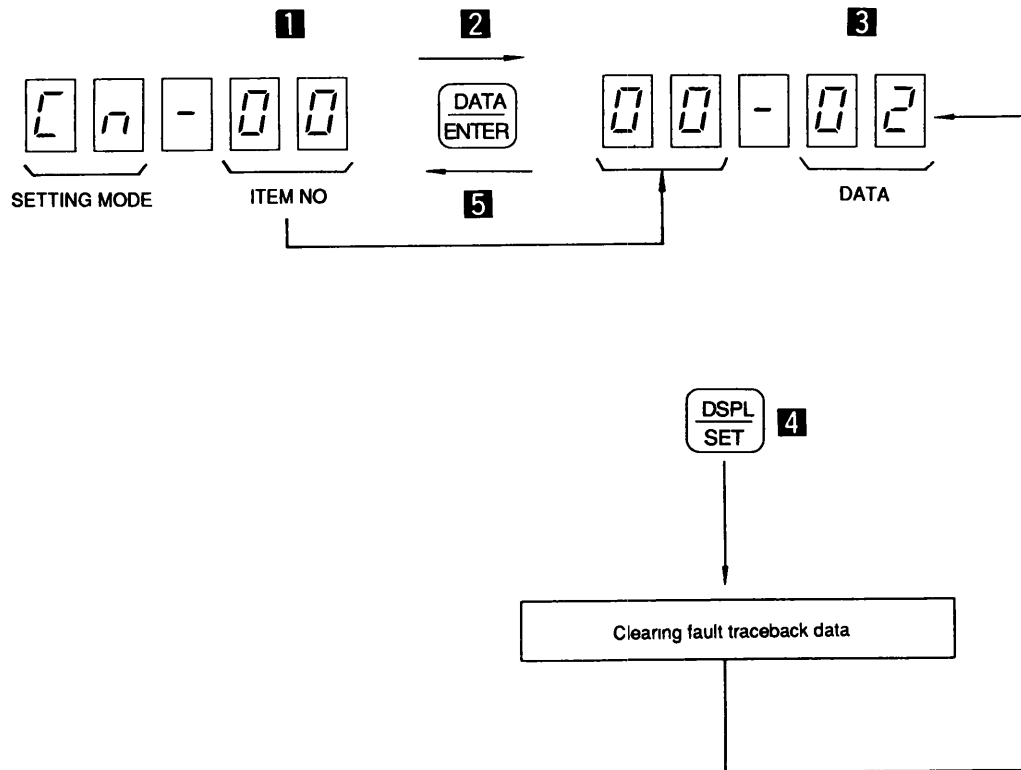













Fig 8 8 Clearing Fault Traceback Data

- 1 Select the item number 00 with the , ,  or  key.
- 2 With the  key, display the data related to the selected item number.
- 3 With the , ,  or  key, select the number 02.
- 4 With the  key, clear fault traceback data and return to the user constant Cn-00 data display status.
- 5 With the  key, return to the item No. display status.
- 6 Using the  key, switch from the setting mode to the monitor mode.

8.4.6 Check of Motor Parameters

(1) Check Method of Motor Parameters

When user constant Cn-00 is set to 05, the system enters the motor parameter check mode.

Panel Display

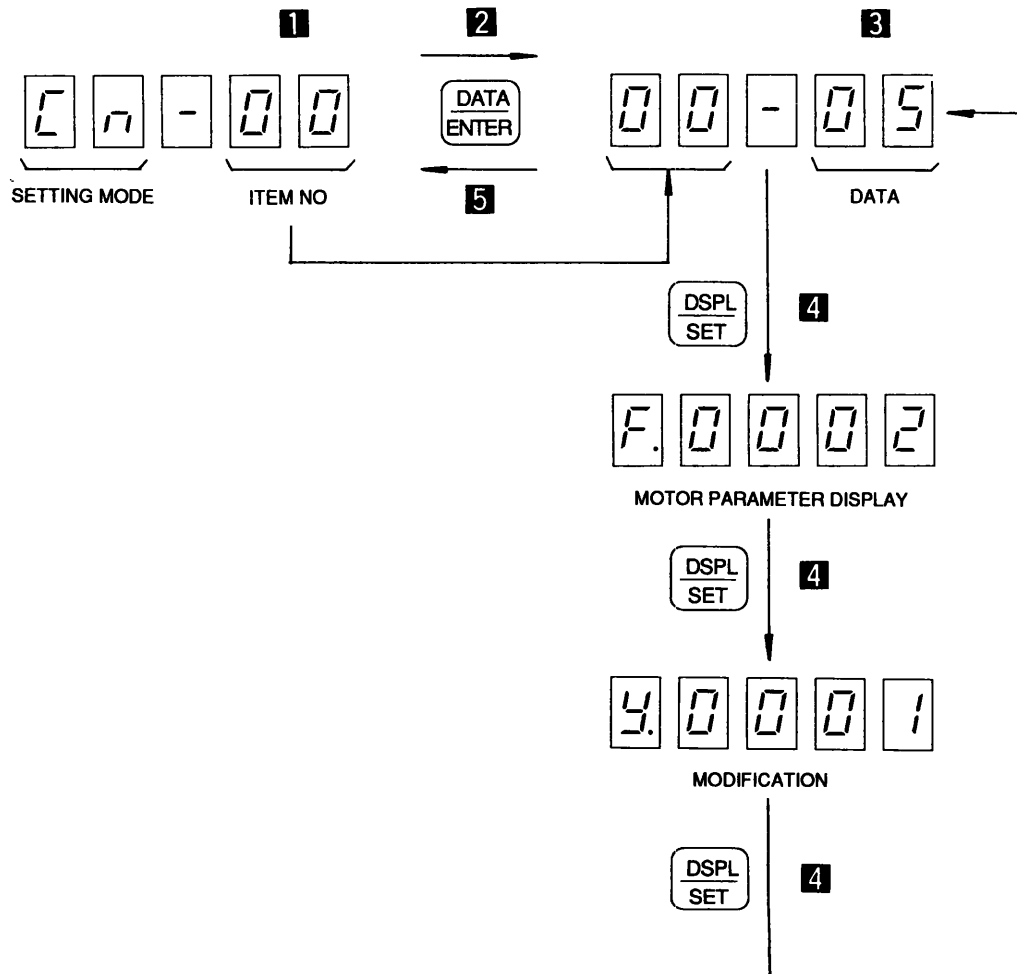













Fig. 8.9 Switch Functions in Motor Parameter Check

- 1** Set up item number 00 with the , ,  or  key.
- 2** With the  key, display the data related to the selected item number.
- 3** With the , ,  or  key, select the number 05.
- 4** With the  key, check the motor parameter.
- 5** With the  key, return to the item No. display status.
- 6** Using the  key, switch from the setting mode to the monitor mode.

8.4.6 Check of Motor Parameters (Cont'd)

(2) Parameter Display

- Motor Parameter

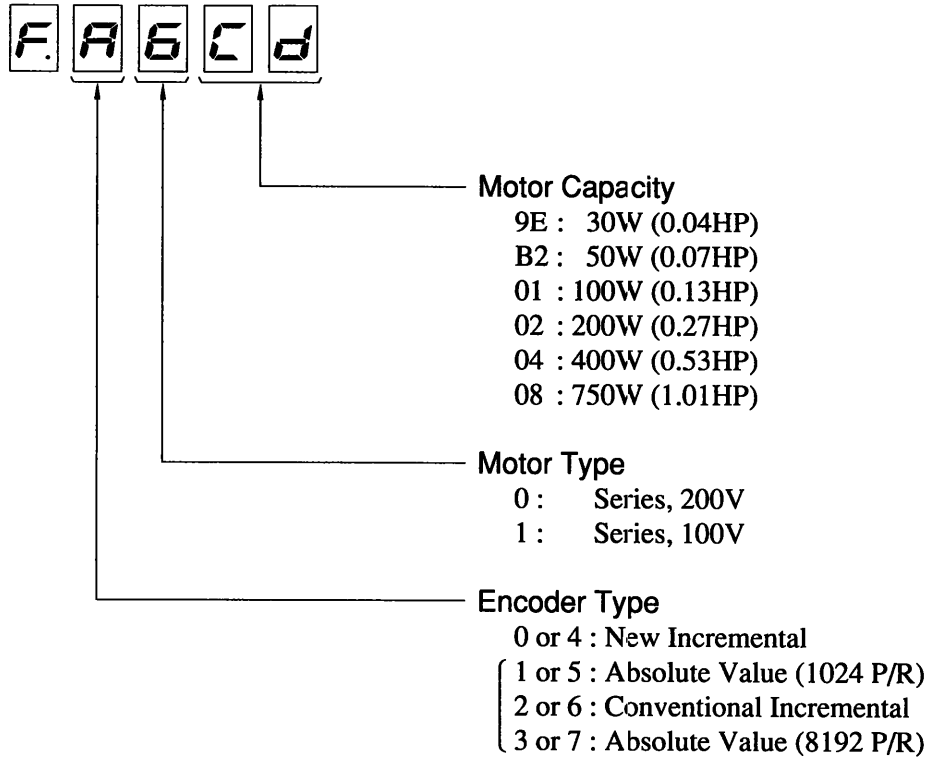

8.5 MONITOR MODE

In this mode, the speed reference, torque reference, and other data can be monitored on the digital operator. Table 8.4 lists the data that can be monitored.

Table 8 4 Data Monitored

Monitor No	Data Monitored
00	Feedback Speed (r/min)
01	Speed Reference (r/min)
02	Torque Reference (%)
03	No of Pulses from Phase-U edge (Pulse)
04	Electrical Angle (deg)
05	Internal Status Bit Display 1 (Refer to Table 8 5)
06	Internal Status Bit Display 2 (Refer to Table 8 5)
07	Reference Pulse Speed Display (r/min)
08	Position Deviation (Pulse)

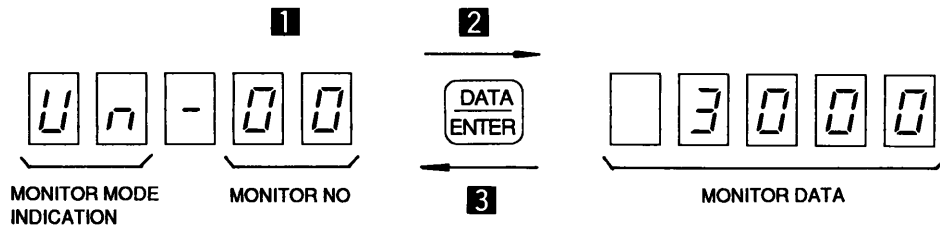







Fig 8 13 Switch Functions in Monitor Mode

- 1** With the  or  key, select a desired monitor No.
- 2** With the  key, initiate monitor display.
- 3** Using the  key, return to the monitor No. selection status.
- 4** With the  key, switch from the monitor mode to the fault traceback mode.

8.5 MONITOR MODE (Cont'd)

Table 8 5 Bit Indication of Monitor Mode Un-05 and -06 Internal Status

	Bit No	Symbol	Contents		
Un-05	①	SVALM	Turns ON at servo alarm		
	②	P-CL	Turns ON during forward current limit ($\overline{N-CL}$ input)		
	③	DIR	Turns ON in reverse run mode		
	④	CLT	Turns ON during current limit		
	⑤	N-CL	Turns ON during reverse current limit ($\overline{N-CL}$ input)		
	⑥	MSON	Turns ON at mode switch ON		
	⑦	ACON	Turns ON at AC power supply ON		
	⑧	SVRDY	Turns ON at servo ready		
	⑨	B-ON	Turns ON under motor current conduction		
	⑩	PA	Turns ON at phase-A output "H"		
	⑪	PB	Turns ON at phase-B output "H"		
	⑫	PC	Turns ON at phase-C output "H"		
	⑬	PU	Phase-U		
	⑭	PV	Phase-V		
	⑮	PW	Phase-W		
	⑯	SVON	Turns ON at servo ON		
	⑰	P-CON	Turns ON during P-drive input		
	⑱	P-OT	Turns ON at forward running prohibit input		
	⑲	N-OT	Turns ON at reverse running prohibit input		
	Un-06	①	PUL	Turns ON at reference pulse input.	
②		SIGN	Turns ON at sign input		
③		CLR	Turns ON at deviation counter clear		
④ ⋮ ⑳					

* Turns ON only at position control motor.

8.6 FAULT TRACEBACK MODE

In this mode, information on past fault occurrences can be displayed.

- Information on up to 10 past fault occurrences can be stored.
- When a fault is reset or the control power is turned ON, traceback data A.99 is saved (These data are also counted as one of a total of 10 stored items of fault information.)
- For the relationship between traceback data and fault descriptions, refer to Table 8.6.

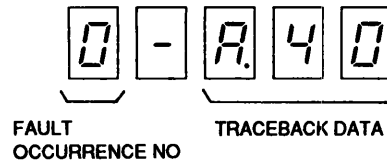





Fig 8 14 Fault Traceback Mode

- 1 With the  or  key, increase or decrease the fault occurrence number.

The fault information related to the selected number is then displayed. (The higher the fault occurrence number, the older the fault occurrence.)

- 2 With the  key, switch from the fault traceback mode to the status display mode.

8.6 FAULT TRACEBACK MODE (Cont'd)

Table 8 6 Error Displays with Digital Operator and Traceback Data

Digital Operator (Traceback Data)	Alarm Contents
A02	Parameter Breakdown
A04	Parameter Setting Error
A 10	Overcurrent or Heatsink Overheat
A20	Fuse Blown
A30	Regenerative Fault
A31	Overflow
A40	Overvoltage
A51	Feedback Overspeed
A52	Overspeed Reference Input
A60	Undervoltage
A71	Overload (Momentary Overload)
A72	Overload (Continuous Overload)
A62	Reference Input Read Error
AC1	Overrun
AC3	PA-, PB-Phase Disconnection of PG Signal Line
AC4	PC Disconnection of PG Signal Line
A99	Not Applicable to Alarm
CPFD1 *	CPU Error  is displayed (SERVOPACK 7-seg LED)

* Not detected as trace back data

9. INSTALLATION AND WIRING

9.1 RECEIVING

This motor has been put through stringent tests at the factory before shipment.

After unpacking, however, check for the following.

- Its nameplate ratings meet your requirements.
- It has sustained no damage while in transit.
- The output shaft can be hand-rotated freely. However, motors with holding brake do not rotate.
- Fastening bolts and screws are not loose.

If any part of the motor is damaged or lost, immediately contact your Yaskawa representative giving full details and nameplate data.

9.2 INSTALLATION

9.2.1 SGM SERVOMOTOR

AC SERVOMOTOR can be installed either horizontally or vertically.

(1) Before Mounting

Wash off anticorrosive paint on shaft extension and flange surface with thinner before connecting the motor to the driven machine. Do not subject other parts of the motor to thinner.

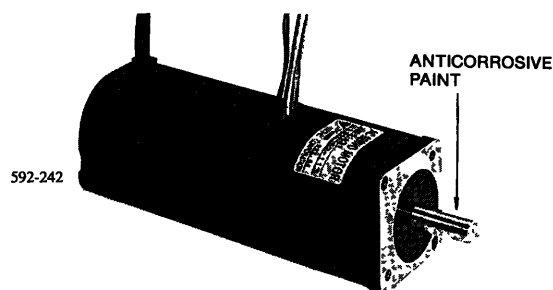

Fig 9 1 Anticorrosive Paint to be Removed

(2) Location

Use the motor under the following conditions.

- Indoors
- Free from corrosive and/or explosive gases or liquids
- Ambient temperature : 0 to + 40°C
- Accessible for inspection maintenance and cleaning

If the AC SERVOMOTOR is subject to excessive water or oil droplets, protect the motor with a cover.

(3) Environmental Conditions

- Ambient Temperature : 0 to + 40°C
- Storage Temperature : -20 to + 60°C
- Humidity : 20 to 80%RH (non-condensing)

9.2.1 SGM SERVOMOTOR (Cont'd)

(4) Load Coupling

True alignment of motor and driven machine is essential to prevent vibration, reduced bearing and coupling life, or shaft and bearing failures.

Use flexible couplings for direct drives. Alignment should be made in accordance with Fig. 9.2.

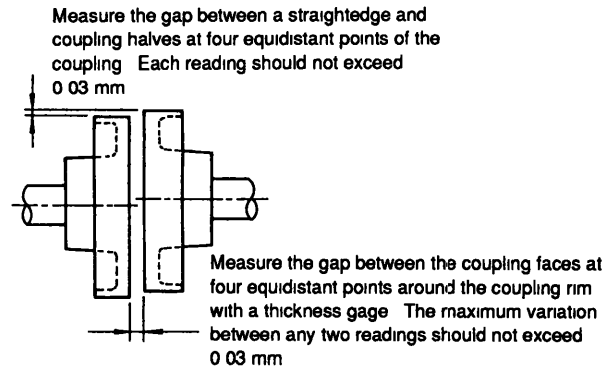

Fig 9.2 Alignment of Coupling

(5) Allowable Bearing Load

Avoid shock to the motor shaft when mounting gear box, coupling or pulley (50 G or less). Don't exceed thrust and radial loads specified in Table 4.1.

9.2.2 DR1 SERVOPACK

(1) Installation

DR1 SERVOPACK (type DR1-) is a rack-mounted type.

(2) Location

- When installed in a panel :
Keep the ambient temperature around DR1 SERVOPACK at 55°C or below.
- When installed near a heat source :
Keep the ambient temperature around DR1 SERVOPACK below 55°C.
- If subjected to vibration :
Mount the unit on shock absorbing material.
- If corrosive gases are present :
Avoid locations where corrosive gases exist since it may cause extensive damage over long use. Contactors and relays are especially vulnerable.

(3) Mounting Direction

Mount the unit vertically on the wall using the mounting holes on the base plate, with main terminals at the bottom. (Fig. 9.3)

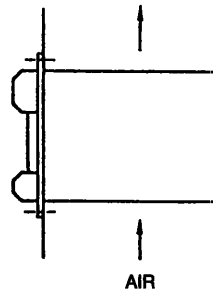

Fig. 9.3 Mounting of DR1 SERVOPACK

9.3 WIRING

9.3.1 Rated Current and Cable Size

Table 9.1 show external terminals, rated current, and cable sizes of the power unit and SERVOPACK. Select the type and size of cables to meet ambient conditions and current capacity.

Table 9.1 Rated Current

External Terminal		Symbol	Rated Current A (rms) (Effective Current)									
			200VAC						100VAC			
			DRI-A3AC	DRI-A5AC	DRI-01AC	DRI-02AC	DRI-04AC	DRI-8AC	DRI-A3BC	DRI-A5BC	DRI-01BC	DRI-02BC
On Line	Main Circuit Power Input	ⓑ ⓓ	1.3	1.5	2.5	4.0	6.0	11.0	2.0	2.6	4.5	8.0
	Motor Connection	Ⓤ Ⓥ Ⓦ	0.42	0.6	0.87	2.0	2.6	4.4	0.63	0.90	2.2	2.7
	Control Power Input	Ⓣ Ⓢ	0.5									
Off Line	Control I/O Signal Connector	1CN	100 mA DC max									
	PG Signal Connector	2CN	100 mA DC max (500 mA for power line only)									
	Ground	≡	—									

Notes

- 1 For main circuits and control power, use cables of 600 V or more, and for motor, line, use cables of 300 V or more
- 2 Where cables are bundled or run in a duct (unplasticized polyvinyl chloride conduit or metallic conduit), select a cable size larger than listed considering the current drop rate of the cables
- 3 Where the ambient (panel interior) temperature is high (40°C to 60°C), use heat-resistant cables

9.3.2 Wiring Precautions

SERVOPACK is a device for speed control of 5000 : 1, and signal level of several milli-volts or less. The following precautions should be taken when wiring.

- (1) For signal lines and PG feedback lines, use twisted cables or multi-core shielded twisted-pair cables (Yaskawa Drawing No. B9400064 etc.). Cable length is a maximum of 3 m for reference input lines and a maximum of 20 m for PG feedback lines. Use the shortest possible length.
- (2) For ground line, cable should be as heavy as possible to provide Class 3 ground (ground resistance 100 Ω or less). Use central grounding point. If the motor and machine are insulated, ground the motor.
- (3) To prevent malfunction due to noise, take the following precautions :
 - Place noise filters, DR1 SERVOPACK and I/O reference as near as possible to each other.
 - Make sure to insert a surge suppressing circuit into the relay, electromagnetic contact, and solenoid coils.
 - Run the power line and signal line, keeping the distance to 30 cm or more ; do not run them in the same duct or in a bundle.
 - When the same power is used for SERVOPACK as for an electric welder or electrical discharge machine or when a high-frequency noise source is present in the vicinity, use filters in the power and input circuits.
 - The SERVOPACK uses a switching amplifier, and electrical noise may be present in the signal line.
- (4) Remedy for Radio Frequency Interference (R.F.I)
DR1 SERVOPACK may interfere with radio reception. If the controller interferes with radio reception, connect a noise filter to the power supply.
- (5) The signal line uses cables whose cores are extremely fine (0.2 to 0.3 mm²). Avoid using excessive force which may damage these cables.

10. OUTSIDE DIMENSIONS in mm (inches)

10.1 SGM SERVOMOTOR

(1) With Incremental Encoder, without Brake

- 30 W (0.04 HP), 50 W (0.07 HP), 100 W (0.13 HP)

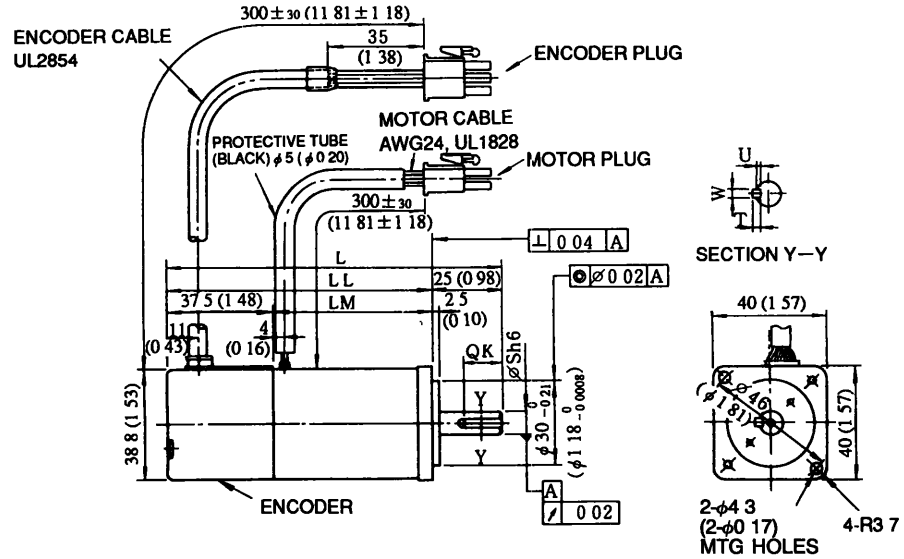

Type SGM-	L	LL	LM	S	QK	U	W	T	Output W (HP)	Rated Torque N m (lb in)	Speed r/min	Mass g (lb)	Allowable Radial Load N (lb)	Allowable Thrust Load N (lb)
A3A312	94.5 (3.72)	69.5 (2.74)	32.0 (1.26)	6 (0.24)	Without key				30 (0.04)	0.095 (0.845)	3000	300 (0.66)	49 (11)	19 (4)
A3B312					14 (0.55)	12 (0.05)	2 (0.08)	2 (0.08)						
A3A314	102.0 (4.02)	77.0 (3.03)	39.5 (1.56)	6 (0.24)	Without key				50 (0.07)	0.159 (1.49)	3000	400 (0.88)	68 (15)	19 (4)
A3B314					14 (0.55)	12 (0.05)	2 (0.08)	2 (0.08)						
A5A312	119.5 (4.70)	94.5 (3.72)	57.0 (2.24)	8 (0.31)	Without key				100 (0.13)	0.318 (2.82)	3000	500 (1.10)	68 (15)	19 (4)
A5B312					14 (0.55)	18 (0.07)	3 (0.12)	3 (0.12)						
A5B314														

Notes

- 1 Detector uses incremental encoder 2048 P/R
- 2 As for type designation, "A" shows that SERVOMOTOR applies 200 VAC power and "B" shows that SERVOMOTOR applies 100 VAC power

• 200 W (0.27 HP), 400 W (0.53 HP)

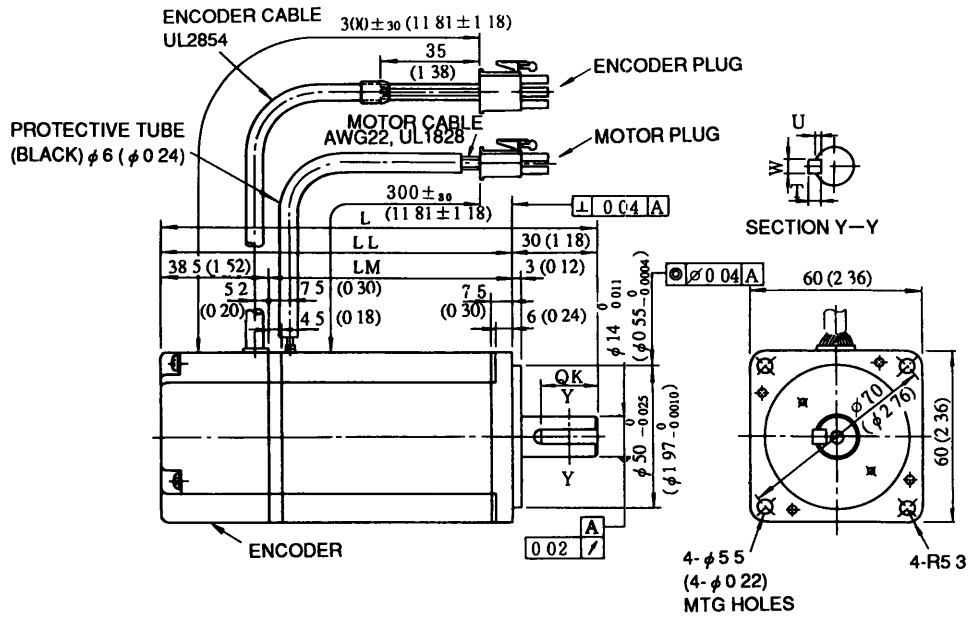

Type SGM-	L	LL	LM	QK	U	W	T	Output W (HP)	Rated Torque N m (lb in)	Speed r/min	Mass g (lb)	Allowable Radial Load N (lb)	Allowable Thrust Load N (lb)
02A312	126 5 (4 98)	96 5 (3 80)	58 0 (2 28)	Without key				200 (0 27)	0 637 (5 63)	3000	1100 (2 43)	196 (44)	49 (11)
02B312				20 (0 79)	3 (0 12)	5 (0 20)	5 (0 20)						
02A314				20 (0 79)	3 (0 12)	5 (0 20)	5 (0 20)						
02B314				20 (0 79)	3 (0 12)	5 (0 20)	5 (0 20)						
04A312	154 5 (6 08)	124 5 (4 90)	86 0 (3 39)	Without key				400 (0 53)	1 27 (11 3)	3000	1700 (3 75)	196 (44)	68 (15)
04A314				20 (0 79)	3 (0 12)	5 (0 20)	5 (0 20)						

Notes

- 1 Detector uses incremental encoder 2048 P/R
- 2 As for type designation, "A" shows that SERVOMOTOR applies 200 VAC power and "B" shows that SERVOMOTOR applies 100 VAC power

• 750 W (1.01 HP)

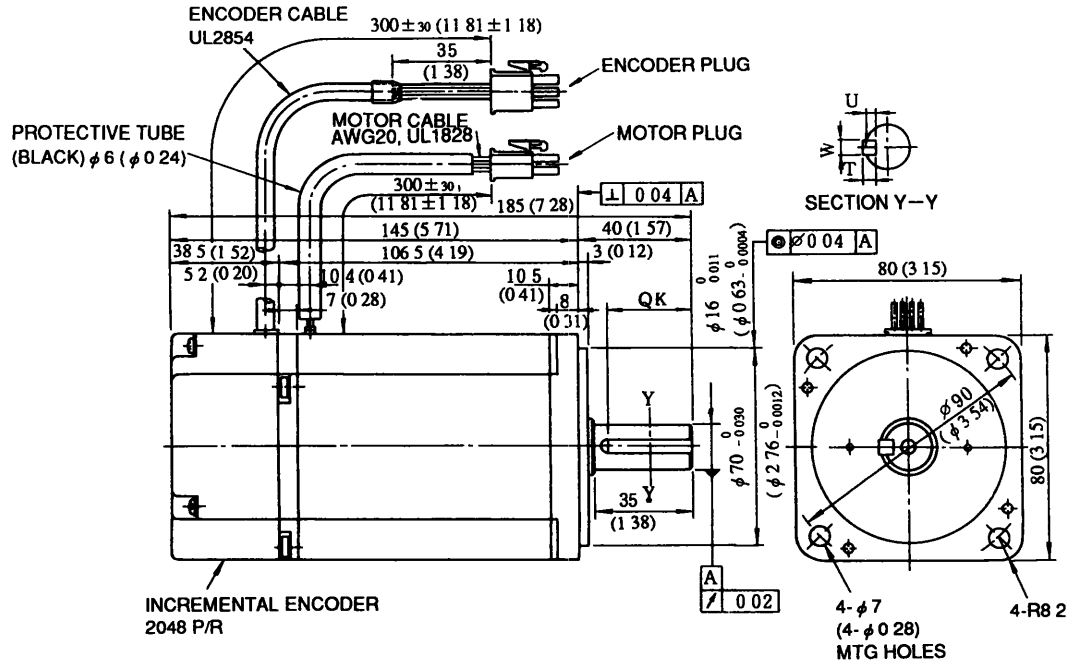

Type SGM-	QK	U	W	T	Output W (HP)	Rated Torque N m (lb in)	Speed r/min	Mass g (lb)	Allowable Radial Load N (lb)	Allowable Thrust Load N (lb)
08A312	Without Key				750 (1 01)	2 39 (21 1)	3000	3400 (7 50)	343 (77)	98 (22)
08A314	30 (1 18)	3 (0 12)	5 (0 20)	5 (0 20)						

Notes

- 1 Detector uses incremental encoder 2048 P/R
- 2 As for type designation, "A" shows that SERVOMOTOR applies 200 VAC power

- (2) With Incremental Encoder, with Brake
- 30 W (0.04 HP), 50 W (0.07 HP), 100 W (0.13 HP)

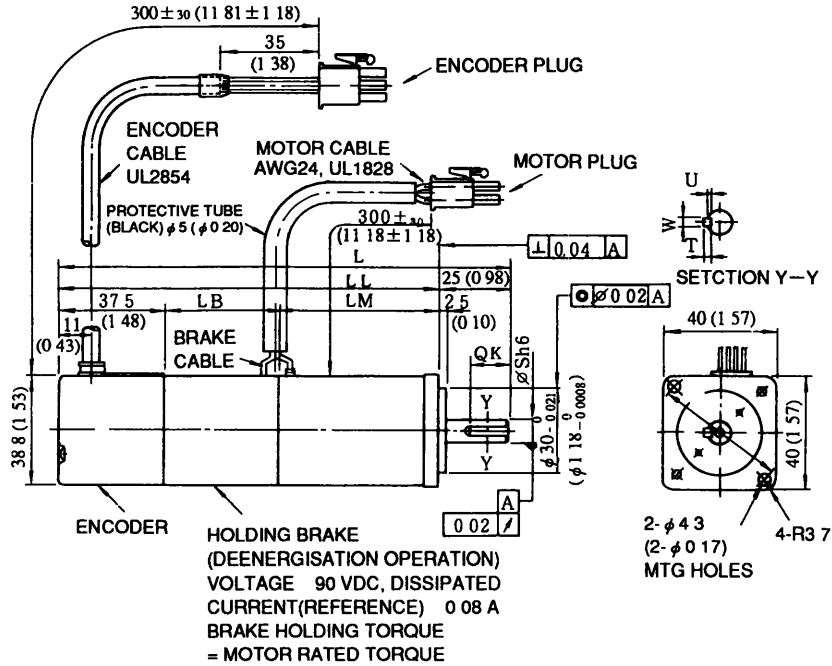

Type SGM-	L	LL	LM	LB	S	QK	U	W	T	Output W (HP)	Rated Torque N m (lb in)	Speed r/min	Mass g (lb)	Allowable Radial Load N (lb)	Allowable Thrust Load N (lb)
A3A312B						Without key				30 (0 04)	0 095 (0 845)	3000	600 (1 32)	49 (11)	19 (4)
A3B312B	126 5 (4 96)	101 0 (3 98)	32 0 (1 26)	31 5 (1 24)	6 (0 24)	14 (0 55)	1 2 (0 05)	2 (0 08)	2 (0 08)						
A3A314B						Without key				50 (0 07)	0 159 (1 49)		700 (1 54)	68 (15)	19 (4)
A3B314B	133 5 (5 26)	108 5 (4 27)	39 5 (1 56)	31 5 (1 24)	6 (0 24)	14 (0 55)	1 2 (0 05)	2 (0 08)	2 (0 08)						
A5A312B						Without key				100 (0 13)	0 318 (2 82)		800 (1 76)	68 (15)	19 (4)
A5B312B	160 0 (6 30)	135 0 (5 31)	57 0 (2 24)	40 5 (1 59)	8 (0 31)	14 (0 05)	1 8 (0 07)	3 (0 12)	3 (0 12)						
A5A314B						Without key				100 (0 13)	0 318 (2 82)	800 (1 76)		68 (15)	19 (4)
A5B314B	160 0 (6 30)	135 0 (5 31)	57 0 (2 24)	40 5 (1 59)	8 (0 31)	14 (0 05)	1 8 (0 07)	3 (0 12)	3 (0 12)						

Notes

- 1 Detector uses incremental encoder 2048 P/R
- 2 As for type designation, "A" shows that SERVOMOTOR applies 200 VAC power and "B" shows that SERVOMOTOR applies 100 VAC power

- 200 W (0.27 HP), 400 W (0.53 HP)

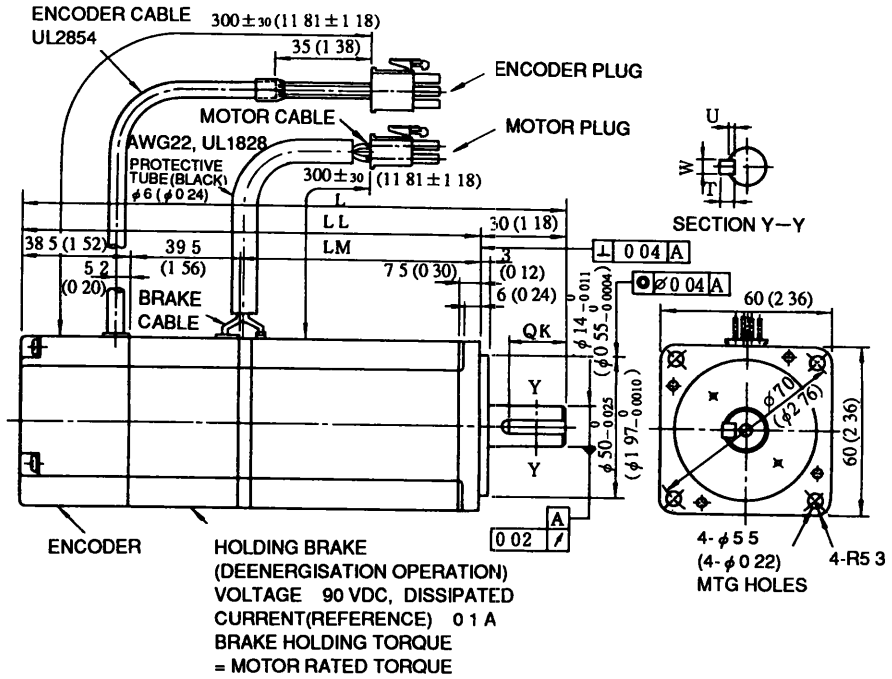

Type SGM-	L	LL	LM	QK	U	W	T	Output W (HP)	Rated Torque N m (lb in)	Speed r/min	Mass g (lb)	Allowable Radial Load N (lb)	Allowable Thrust Load N (lb)
02A312B				Without key				200 (0 27)	0 637 (5 63)	3000	1600 (3 53)	196 (44)	49 (11)
02B312B	166 0 (6 54)	136 0 (5 35)	58 0 (2 28)	20 (0 79)	3 (0 12)	5 (0 20)	5 (0 20)						
04A312B				Without key				400 (0 53)	1 27 (11 3)	3000	2200 (4 85)	196 (44)	68 (15)
04B312B	194 0 (7 64)	164 0 (6 46)	86 0 (3 39)	20 (0 79)	3 (0 12)	5 (0 20)	5 (0 20)						

Notes

- 1 Detector uses incremental encoder 2048 P/R
- 2 As for type designation, "A" shows that SERVOMOTOR applies 200 VAC power and "B" shows that SERVOMOTOR applies 100 VAC power

• 750 W (1.01 HP)

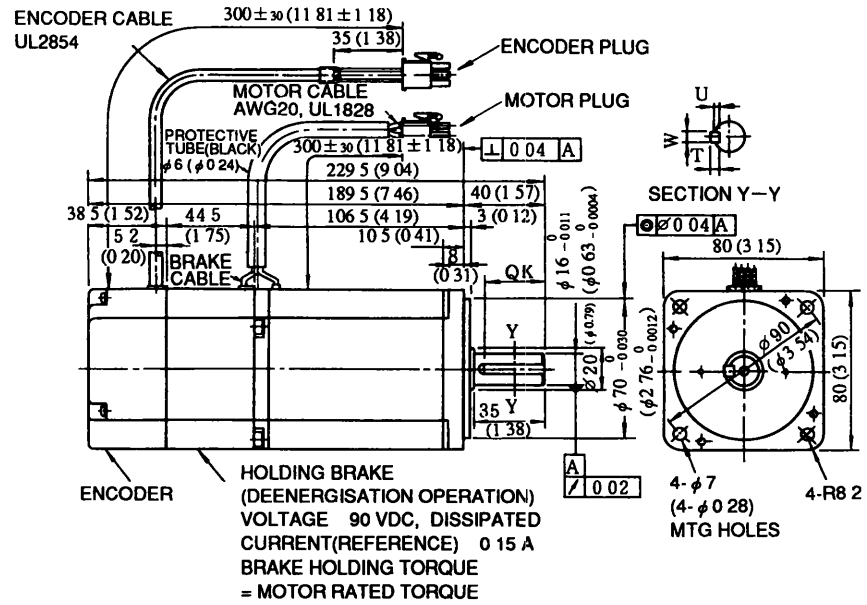

Type SGM-	QK	U	W	T	Output W (HP)	Rated Torque N m (lb in)	Speed r/min	Mass g (lb)	Allowable Radial Load N (lb)	Allowable Thrust Load N (lb)
08A312B	Without key				750 (1 01)	2 39 (21 1)	3000	4300 (9 48)	343 (77)	98 (22)
08A314B	30 (1 18)	3 (0 12)	5 (0 20)	5 (0 20)						

Notes

- 1 Detector uses incremental encoder 2048 P/R
- 2 As for type designation, "A" shows that SERVOMOTOR applies 200 VAC power

(3) Connector specifications

Ⓐ Motor plug

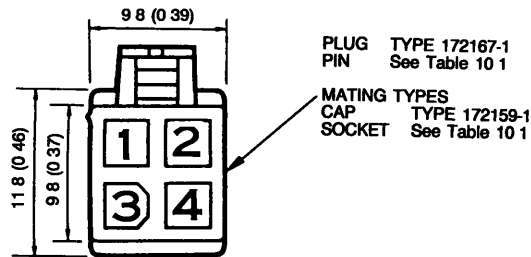

● Motor and brake connection

1	Phase-U	Red
2	Phase-V	White
3	Phase-W	Blue
4	FG (Frame ground)	Green

Ⓑ Motor plug with brake

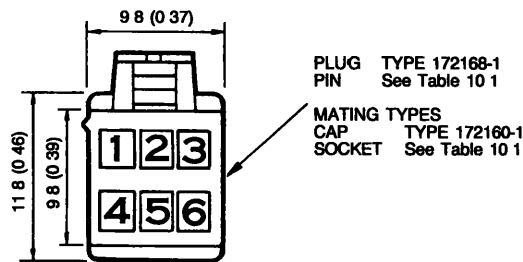

● Motor and brake connection

1	Phase-U	Red
2	Phase-V	White
3	Phase-W	Blue
4	FG (Frame ground)	Green
5	Brake terminal	Black
6	Brake terminal	Black

Ⓒ Encoder plug

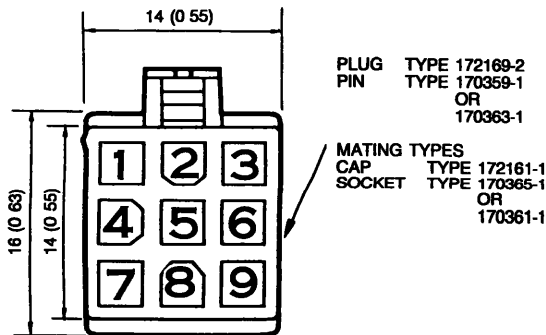

● Incremental encoder connection

1	Channel A output	Blue
2	Channel \bar{A} output	Blue / Black
3	Channel B output	Yellow
4	Channel \bar{B} output	Yellow / Black
5	Channel C output	Green
6	Channel \bar{C} output	Green / Black
7	0 V (Power supply)	Gray
8	+5 V (Power supply)	Red
9	FG (Frame ground)	Orange

* For cap detailed dimensions, see
Par 10 4 "CONNECTOR KIT"

Table 10 1

	30 W, 50 W, 100 W	200 W, 400 W, 750 W
Pin	Type 170359-1 or 170363-1	Type 170360-1 or 170364-1
Socket	Type 170362-1 or 170366-1	

10.2 DR1 SERVOPACK

- Type DR1-A3AC to 02AC [200 V: 30 (0.04 HP) to 200 W (0.27 HP)]
Type DR1-A3BC to 01BC [100V: 30 (0.04 HP) to 100 W (0.13 HP)]

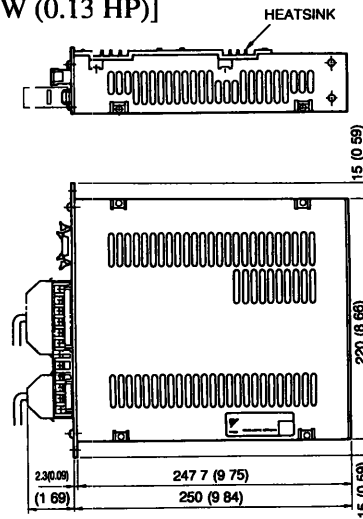
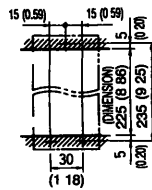
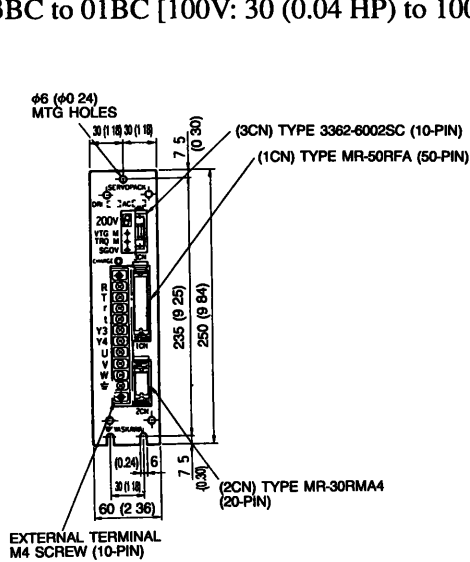

Approx Mass : 2.7kg (5.95lb)

Attachment

1CN connector (for cable)
 Hood type MR-50L
 Housing type MR-50M

2CN connector (for cable)
 Hood type MR-20L
 Housing type MR-20F

- Type DR1-04AC, 08AC [200V: 400W (0.53HP), 750W (1.01HP)]
Type DR1-02BC [100V: 200W (0.27HP)]

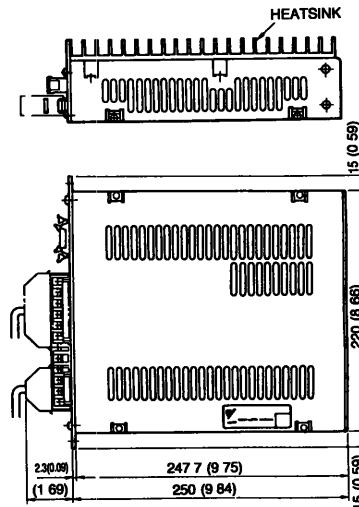
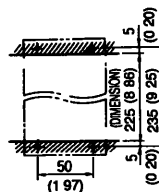
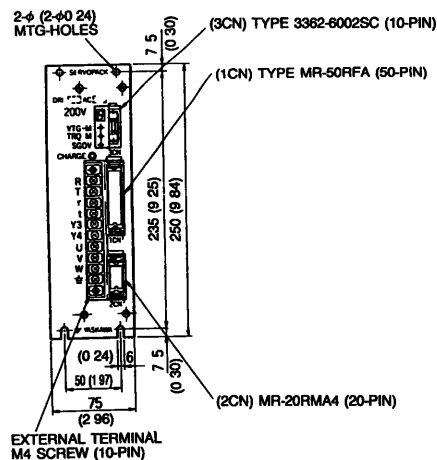

Approx Mass : 3.4kg (7.50lb)

Attachment

1CN connector (for cable)
 Hood type MR-50L
 Housing type MR-50M

2CN connector (for cable)
 Hood type MR-20L
 Housing type MR-20F

10.3 DIGITAL OPERATOR

Type JUSP-OP02A

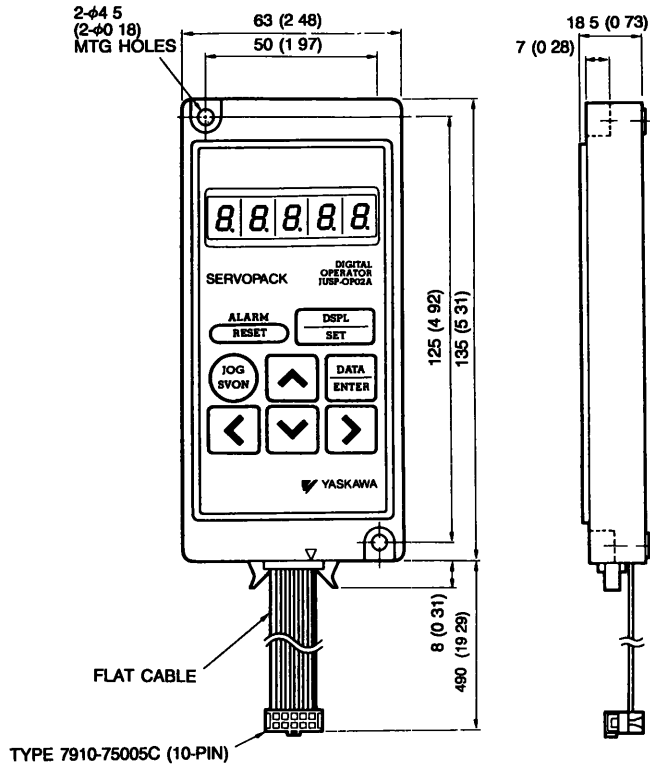

Approx Mass : 2.7kg (5.95lb)

10.4 CONNECTOR KIT

(1) Cap for encoder cable

(2) Cap for motor cable

Type DP9420002

• For motor without brake (Standard)

Type DP9420004

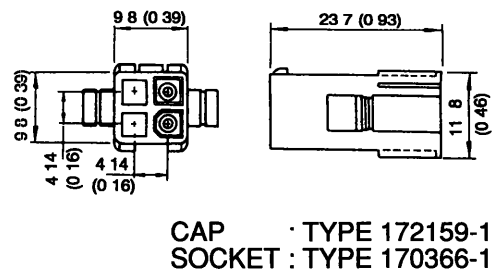
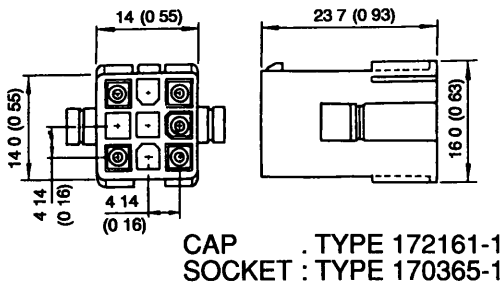

• For motor with brake

Type DP9420005

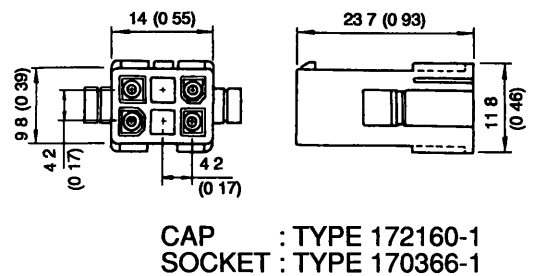

10.5 CABLES

(1) Cable for PG

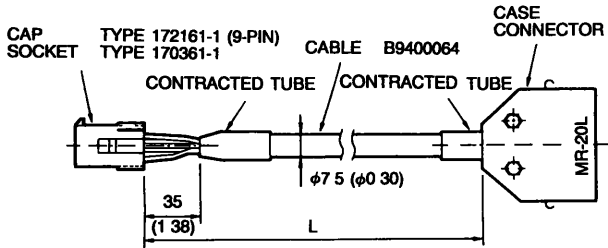

(2) Cable for Motor

• For motor without brake

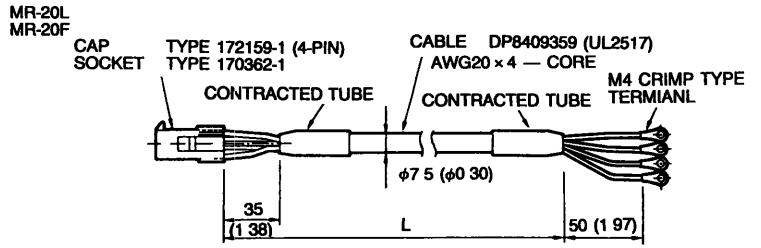

• Cable for PG with double-end connector

Type	L
DP9320082-1	3000 ⁺¹⁰⁰ ₀ (118 11 ^{+3.94} ₀)
DP9320082-2	5000 ⁺¹⁰⁰ ₀ (196 85 ^{+3.94} ₀)
DP9320082-3	10000 ⁺⁵⁰⁰ ₀ (393 70 ^{+19.69} ₀)
DP9320082-4	15000 ⁺⁵⁰⁰ ₀ (590 55 ^{+19.69} ₀)
DP9320082-5	20000 ⁺⁵⁰⁰ ₀ (787 40 ^{+19.69} ₀)

• With connector and amp terminal (4-pin)

Type	L
DP9320081-1	3000 ⁺¹⁰⁰ ₀ (118 11 ^{+3.94} ₀)
DP9320081-2	5000 ⁺¹⁰⁰ ₀ (196 85 ^{+3.94} ₀)
DP9320081-3	10000 ⁺⁵⁰⁰ ₀ (393 70 ^{+19.69} ₀)
DP9320081-4	15000 ⁺⁵⁰⁰ ₀ (590 55 ^{+19.69} ₀)
DP9320081-5	20000 ⁺⁵⁰⁰ ₀ (787 40 ^{+19.69} ₀)
DP9320081-6	1000 ⁺⁵⁰ ₀ (39 37 ^{+1.97} ₀)

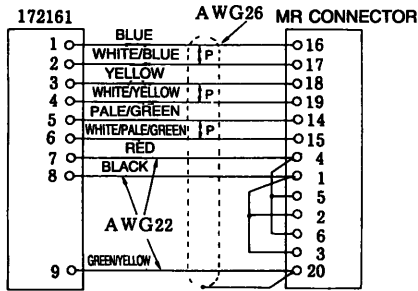

P Twisted pair wires

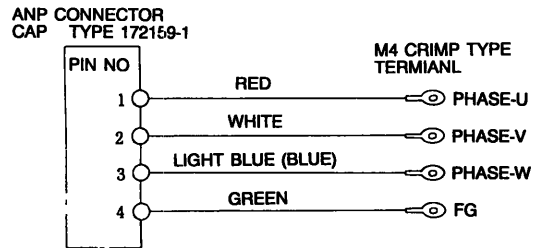

• For motor with brake

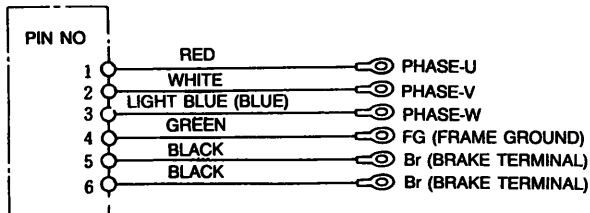
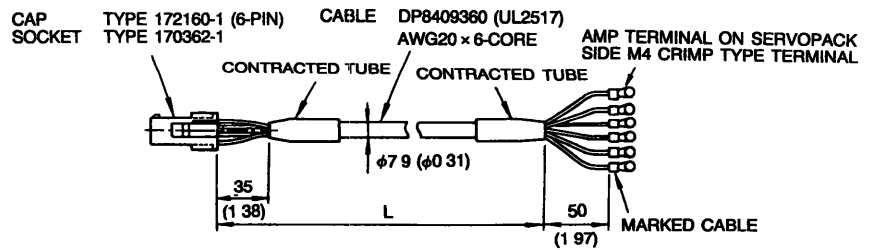

• With connector and amp terminal (6-pin)

Type	L
DP9320083-1	3000 ⁺¹⁰⁰ ₀ (118 11 ^{+3.94} ₀)
DP9320083-2	5000 ⁺¹⁰⁰ ₀ (196 85 ^{+3.94} ₀)
DP9320083-3	10000 ⁺⁵⁰⁰ ₀ (393 70 ^{+19.69} ₀)
DP9320083-4	15000 ⁺⁵⁰⁰ ₀ (590 55 ^{+19.69} ₀)
DP9320083-5	20000 ⁺⁵⁰⁰ ₀ (787 40 ^{+19.69} ₀)

10.6 NOISE FILTER

• Type LE-205A

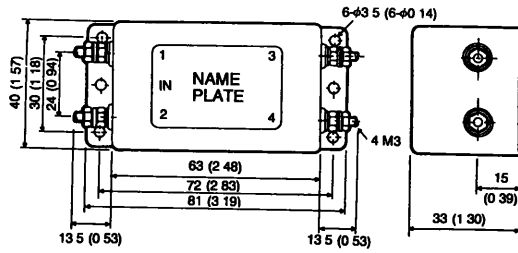

• Type LF-210

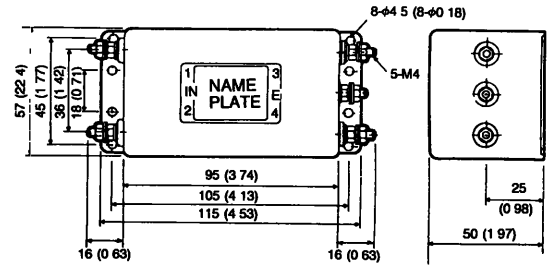

• Type LF-220

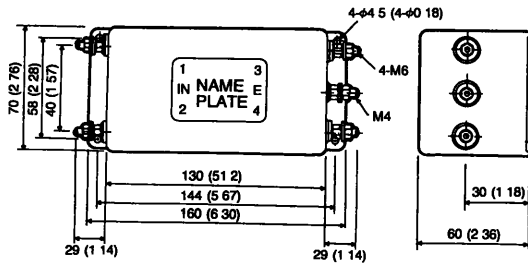

Made by Torikin Corp.

10.7 PERIPHERAL DEVICES

(1) Variable Resistor for Speed Setting

- Type 25HP-10B

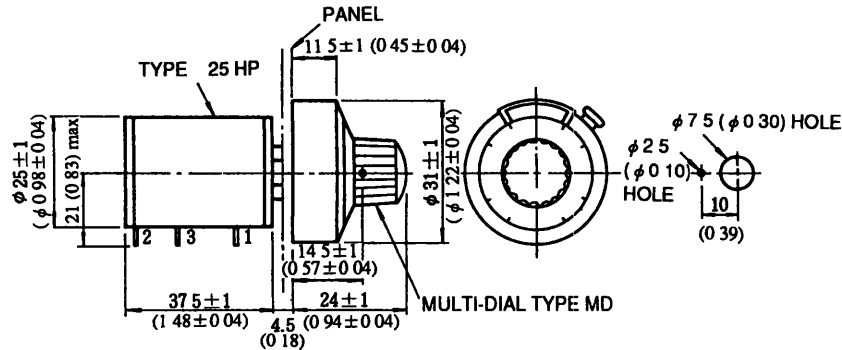

(2) Power Supply for Brake

Two types of power supply for brake (100/200 VAC).

- 100 VAC/90 VDC (DP8401002-2)
- 200 VAC/90 VDC (DP8401002-1)

- Internal circuit for 100 VAC

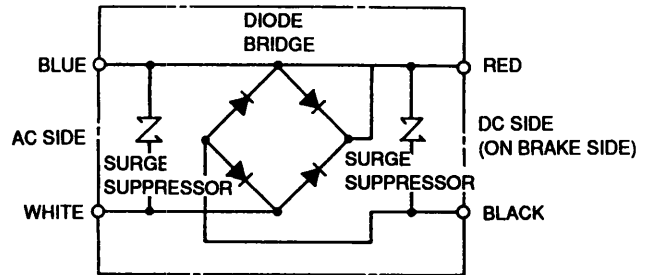
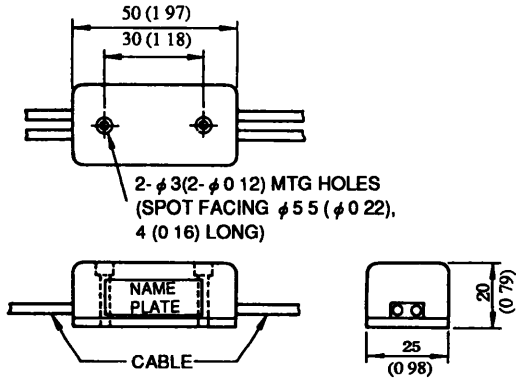

- Internal circuit for 200 VAC

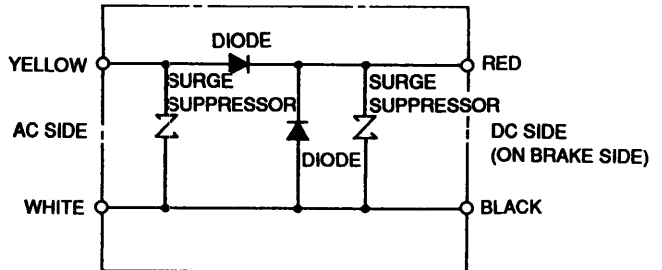

- Cable length : 500 mm each
- Cables are distinguished by color.

AC Input Side		On Brake Side
100V	200V	
Blue, White	Yellow, White	Red, Black

Note : The brake power circuit can be turned ON and OFF on either the AC or DC side. Normally, switching on the AC side is safer. If switched on the DC side, surge voltage may damage the brake coil. To avoid this, place a surge suppressor near the brake coil.

- Max. ambient temperature : 60°C

11. TEST RUN

Before test run, check the following. Correct any deficiency.

11.1 CHECK ITEMS BEFORE TEST RUN

11.1.1 SGM SERVOMOTOR

Before test run, check the following. If the test run is performed after long storage, see Par. 13, "INSPECTION AND MAINTENANCE."

- Connection to machines or devices, wiring, and grounding are correct.
- Bolts and nuts are tightened.
- For motors with shaft seals, the seals are not damaged and motor is properly lubricated.

11.1.2 DR1 SERVOPACK

- User constants are correctly set to satisfy the specifications for the applicable SERVOMOTOR.
- Connection and wiring leads are firmly connected to terminals or inserted into the connectors.
- The power supply is turned OFF if servo alarm occurs.
- Voltage supplied to DR1 SERVOPACK is 200 to 230 VAC $\begin{matrix} +10\% \\ -15\% \end{matrix}$ (100 to 115 VAC $\begin{matrix} +10\% \\ -15\% \end{matrix}$).
If a voltage line other than 200 V (100 V) is used, the voltage should be dropped to 200 V (100 V) through a power transformer.
- The speed reference should be 0 V

11.2 TEST RUN PROCEDURES



11.2.1 Preparation for Operation

During test run, loads should not be applied to the SERVOMOTOR. If it is necessary to start with the driven machine connected to the motor, confirm that the driven system is ready for emergency stop at any time.

(1) Power ON

After checking items in Par. 6.1, turn ON the power supply. When the power ON Sequence is correct, according to Par. 6.1, the power is turned ON by depressing the POWER pushbutton for approximately 1 second.

- (2) When a digital operator is used, the display shown below appears when power is supplied normally. (This display appears when the motor stops.)

 (Turns ON  and LED for main power supply )

11.2.1 Preparation for Operation (Cont'd)

- (3) Inputting the servo ON signal (by switching ON the contact) activates the power circuit in the DR1 SERVOPACK to be ready to drive the motor. (The display shown below appears on the digital operator, provided that the motor is stopped.)

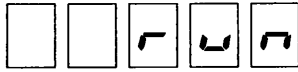

11.2.2 Operation

The operation is possible only while Servo ON signal is ON.

• In Speed Control Mode

- (1) Increase the speed reference voltage gradually from 0V, then the motor rotates at a speed proportional to the reference voltage.

• In Position Control Mode

- (1) Input low frequency reference pulse continuously to operate the motor at a low speed. The motor rotating speed is in proportion to reference pulse frequency and the motor rotating angle is in proportion to the number of turning-on pulses.



- (2) When the reference voltage is positive, the motor rotates in the forward direction (counterclockwise rotation when viewed from the shaft extension).

- (2) Check that the motor rotating direction coincides properly with the forward or reverse run command (differs depending on reference pulse input form). The motor stops when supply of reference pulse is stopped.

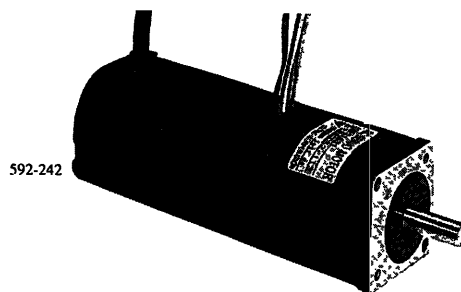

11.2.3 Inspection during Test Run

The following items should be checked for during the test run.

- Unusual vibration
- Abnormal noise
- Excessive temperature rise

If any fault is found, take corrective actions according to Par. 14. At a test operation, the load and machine may not fit well at first and result in overload.

12. ADJUSTMENT

12.1 CHARACTERISTICS PRESET AT THE FACTORY PRIOR TO SHIPMENT

Standard factory setting is speed control mode. To change to position control mode, set up bit B of user constant Cn-02. Characteristics preset at the factory are shown below.

- In Speed Control Mode

(1) Speed Reference Input–SERVOMOTOR Speed Ratio

Condition : No load

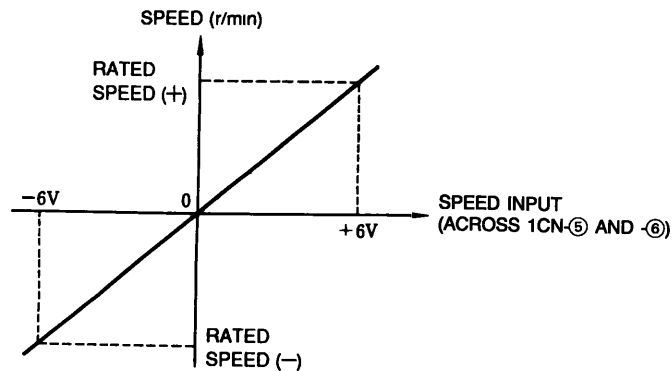

Fig 12 1 Speed Reference Input–SERVOMOTOR Speed Ratio

(2) Start–Stop Response Characteristics

Condition :

I_P : Start current set value

Load inertia J_L =motor inertia $J_M \times 3$

Both overshoot (N_{OV}) and undershoot (N_{UD}) are 5% or less.

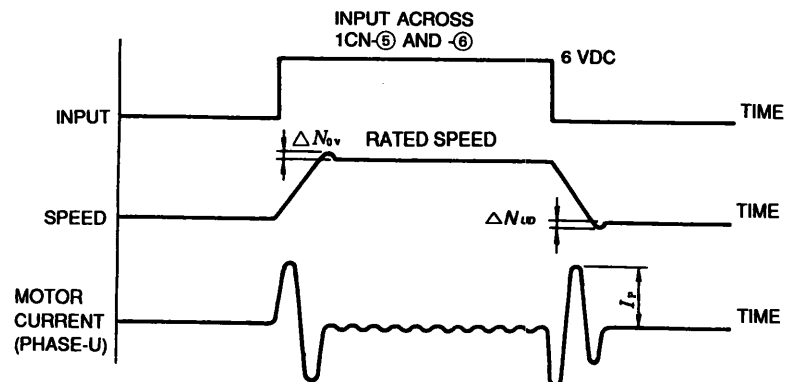

Fig 12 2 Start–Stop Response Characteristics

• In Position Control Mode

(1) Reference Input Frequency–SERVOMOTOR Speed Ratio

Conditions : No load

: Continuous Pulse

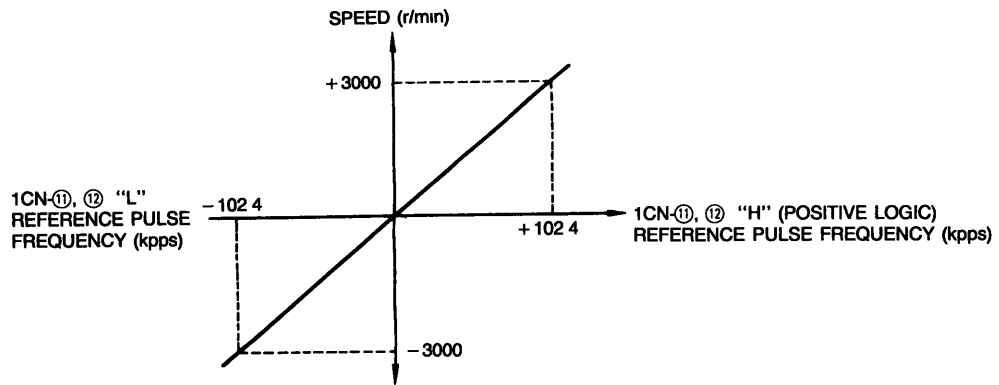

Fig 12 4 Reference Input Frequency–Motor Speed Characteristics

12.2 RESET

If resetting of user constants is necessary, refer to Par. 8, "DIGITAL OPERATOR (JUSP-OP02A)."

13. INSPECTION AND MAINTENANCE

13.1 SGM SERVOMOTOR

SGM SERVOMOTOR has no movable wearing parts (eg. brushes), so simple daily inspection is sufficient. The inspection schedule for the motor is shown in Table 13.1.

Do not disassemble the motor. If disassembly should become necessary, contact your Yaskawa representative.

Table 13 1 Inspection Schedule for Motors

Inspection Item	Frequency	Inspection Operation
Vibration	Daily	Touch by hand
Noise	Daily	Aurally
Exterior and Cleaning	As required	Clean with dry cloth or compressed air
Insulation Resistance	Annually	Make sure that it is more than 10M Ω by measuring with a 500V megger after disconnecting the motor from the controller
Shaft Seal	Every 5000 hours	Replace shaft Seal
Overhaul	Every 20,000 hours or 5 years	Contact your Yaskawa representative

13.2 DR1 SERVOPACK

DR1 SERVOPACK does not require any that no special maintenance is required. Remove dust and tighten screws periodically.

14. TROUBLESHOOTING

14.1 SGM SERVOMOTOR

WARNING

Corrective actions in  should be performed after turning OFF the power.

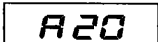
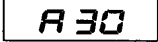
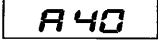



Table 14.1 Troubleshooting Guide for AC SERVOMOTOR

Trouble	Cause	What to do
Motor does not start	Loose connection	Tighten connection
	Wrong wiring	Correct wiring
	Overload	Reduce load or use a larger motor
Unstable operation	Wrong wiring	Inspect and correct wiring across motor terminals U, V, and W, and PG
Motor overheats	Excessive ambient temperature	Reduce ambient temperature below 40°C
	Motor surface is dirty	Clean motor surface
	Overload	Reduce load or use a larger motor
Unusual noise	Motor loosely mounted	Tighten foundation bolts
	Motor misaligned	Realign with driven machine
	Coupling out of balance	Balance coupling
	Noisy bearings	Check alignment noise of bearings, lubrication and contact your Yaskawa representative
	Vibration of driven machine	Contact the machine manufacturer

14.2 DR1 SERVOPACK

14.2.1 LED Indication (7-segment) for Troubleshooting

Table 14.2 LED Indication for Troubleshooting

7-segment LED Indication	Digital Operator Indication* (Traceback Monitor)	Lighting Condition	Probable Cause	Corrective Actions
1	 Overcurrent *	Goes ON when power is supplied to the control circuit	Defective control circuit board (1PWB)	Replace the SERVOPACK
		Goes ON when power is supplied to the main circuit and servo power is turned ON	<ul style="list-style-type: none"> Defective current feedback circuit Defective main circuit transistor module 	<ul style="list-style-type: none"> Replace the SERVOPACK Correct grounding
		Lights during operation Lights even after turning power OFF and then ON again Operation is restarted after turning power OFF, waiting for a while, and resetting	Ambient temperature near the SERVOPACK is over 55°C	Reduce ambient temperature around the SERVOPACK to 55°C or lower (Heatsink overheat)
2	 Fuse blown	Goes ON when power is supplied to the control circuit	Defective control circuit board (1PWB) (Fuse must not be blown)	Replace the SERVOPACK
		Goes ON when power is supplied to the main circuit	Defective main circuit diode module	Replace the SERVOPACK
			Fuse blown	Replace the SERVOPACK
3	 Regenerative Trouble	Goes ON when power is supplied to the control circuit	Defective control circuit board (1PWB)	Replace the SERVOPACK
		Goes ON approximate 0.5 to 1 second after power is supplied to the main circuit	Defective regenerative transistor	Replace the SERVOPACK
			Regenerative resistor disconnection	Check and replace the regenerative resistor (Replace the SERVOPACK)
4	 Overvoltage	Goes ON when the motor accelerates or decelerates	Load inertia J_L is too large	<ul style="list-style-type: none"> Check the inertia of the machine with the value converted to the motor shaft Connect the regenerative unit
			Defective regenerative circuit	Replace the SERVOPACK
5	 Overspeed	When the reference is input, the motor runs fast and LED goes ON	<ul style="list-style-type: none"> Motor connection error Optical encoder connection error 	<ul style="list-style-type: none"> Correct the motor connection Check pulses in phases -A, -B and -C on 2CN and correct wiring
	 Overspeed Reference	When the reference is input, the motor runs fast and LED goes ON	The reference input voltage is too large	Decrease the reference input voltage
6	 Undervoltage	Goes ON when power is supplied to the main circuit	<ul style="list-style-type: none"> Defective main circuit diode module In-rush current preventive resistor disconnection 	Replace the SERVOPACK





* Display format is as indicated 

Table 14.2 LED Indication for Troubleshooting (Cont'd)

7-segment LED Indication	Digital Operator Indication* (Traceback Monitor)	Lighting Condition	Probable Cause	Corrective Actions
7	 Instantaneous Overload	Goes ON during operation When power to the control circuit is turned OFF and then turned ON again, the operation starts	Operation is continued for several seconds to several tens seconds at a torque exceeding the rating	Check for overload and adjust as necessary
	 Continuous Overload	Goes ON during operation When power to the control circuit is turned OFF and then turned ON again, the operation starts	• Operation is continued for several tens of seconds to several hundreds of seconds at a torque exceeding the rating	Check for overload and adjust as necessary
b		Goes ON during operation	Erroneous operation of reference input reader	Resume after reset operation
			Defective reference input reader	Replace the SERVOPACK
c	 Overrun	The motor starts momentarily, then LED goes ON	Motor connection error	Correct the motor connection
			Encoder connection error	Correct wiring of the optical encoder
	 Wire Break with Phase -PA, -PB	The motor starts momentarily, then LED goes ON	Wire break with phase PA or PB of the optical encoder	Correct signal cables of the optical encoder
	 Wire Break with Phase PC	The motor starts momentarily, then LED goes ON	Wire break with phase PC of the optical encoder	Correct signal cables of the optical encoder
-	 Digital operator Transmission Error 2	Goes ON during operation	Defective control circuit board (1PWB)	Replace the SERVOPACK
			Malfunction of the internal circuit	Resume after resetting operation
			Failure of the internal circuit	Replace the SERVOPACK

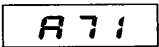
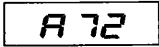
† CPU faults are not recorded in traceback data

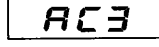
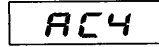
Table 14.2 LED Indication for Troubleshooting (Cont'd)

7-segment LED Indication	Digital Operator Indication* (Traceback Monitor)	Lighting Condition	Probable Cause	Corrective Actions
0	A02 Parameter Failure	Goes ON when power is turned ON	Defective control circuit board (1PWB)	Replace the SERVOPACK
	A04	Goes ON when parameter is changed	Set the value without a setting range by serial communication	Reset the value
3	A31 Overflow	Reference pulse is input but PG pulse is not returned	<ul style="list-style-type: none"> Improper motor connection Improper optical encoder connection 	<ul style="list-style-type: none"> Correct the motor connection Check pulses of phases -A, -B and -C in 2CN and correct if there is disconnection, shortcircuit, no power supply or defective board
			Defective control circuit board (1PWB)	Replace the board (SERVOPACK)
		Operation is performed at high speed causing overflow	<ul style="list-style-type: none"> Improper motor connection Improper optical encoder connection 	<ul style="list-style-type: none"> Correct the motor connection Check pulses of phases -A, -B and -C in 2CN and correct if there is disconnection, shortcircuit, no power supply or defective board
			Defective control circuit board (1PWB)	Replace the board (SERVOPACK)
		Operation is normal but long-term command causes overflow	Improper adjustment of SERVOPACK	Increase the speed loop gain
			Excessive load capacity	Recheck the load (overload, load inertia)
Excessively high reference pulse frequency	Slow reference pulse up and down			

14.2.2 Examples of Troubleshooting for Defective Wiring or Parts (Table 14.3)

Table 14.3 Examples of Troubleshooting for Defective Wiring or Parts

Trouble	Check Items	Corrective Actions
Fuse is blown immediately after Power ON and Servo ON	<ul style="list-style-type: none"> Main circuit wiring (such as motor grounding) 	<ul style="list-style-type: none"> Correct the wiring
The reference is input, but the motor does not run	<ul style="list-style-type: none"> Voltage across ⑧ and ⑨ Alarm LED OFF Speed reference voltage P-CON, N-OT, P-OT, S-ON SEN signal (for absolute encoder) Digital operator display 	<ul style="list-style-type: none"> Check the AC power supply circuit If LED is ON, check the cause Adjust the speed setting potentiometer (supplied by the user)
The reference is input, but the motor does not run at position control	<ul style="list-style-type: none"> Logic and wiring of reference pulse (CW+CCW mode) CLR signal wiring 	<ul style="list-style-type: none"> Correct the wiring Check CLR signal Check the reference pulse mode (Cn-02)

14.2.3 Examples of Errors Resulting Setting Errors (Table 14.4)

Table 14.4 Examples of Errors Resulting Setting Errors

Error Condition	Cause	Corrective Actions
The motor vibrates at a high frequency of about 200 to 300Hz (The vibration frequency matches commercial frequency)	Speed loop gain (influence by induced noise in the SERVOPACK input circuit since the cable is too long or is bundled together with a feeder line)	Adjust Cn-04 LOOP Hz to reduce speed loop gain until vibration stops Separate the input circuit cable from the power lines or receive power to the input circuit from a power supply of a lower impedance (about 100Ω or lower AC is allowable)
Too much overshoot is observed with the rotation speed at acceleration and deceleration	Speed loop gain is too high	Adjust Cn-04 LOOP Hz to reduce speed loop gain until vibration stops
The motor turns even when speed reference voltage is 0V	There is an offset to the speed reference voltage	Adjust the offset to the speed reference voltage (See Par 8 4 4, "Speed Reference Offset Adjustment")

NOTES

Σ SERIES SGM/DR1

AC SERVO DRIVES FOR SPEED-POSITION CONTROL

SERVOMOTOR : TYPES SGM-**A31**, SGM-**B31**

SERVOPACK : TYPES DR1-**AC**, DR1-**BC**

TOKYO OFFICE Ohtemachi Bldg, 1-6-1 Ohtemachi, Chiyoda-ku, Tokyo, 100 Japan
 Phone (03) 3284-9111 Telex YASKAWA J33530 Fax (03) 3284-9034
 SEOUL OFFICE 8th Floor Seoul Center Bldg, 91-1, Sogong-Dong, Chung-ku, Seoul, Korea 100-070
 Phone (02) 776-7844 Fax (02) 753-2639
 TAIPEI OFFICE Shen Hsiang Tang Sung Chiang Building 10F 146 Sung Chiang Road, Taipei, Taiwan
 Phone (02) 563-0010, -7732 Fax (02) 567-4677
YASKAWA ELECTRIC AMERICA, INC
 Chicago-Corporate Headquarters 2942 MacArthur Blvd Northbrook, IL 60062-2028, U S A
 Phone (708) 291-2340 Fax (708) 498-2430
 Chicago-Technical Center 3160 MacArthur Blvd Northbrook, IL 60062-1917, U S A
 Phone (708) 291-0411 Fax (708) 291-1018
MOTOMAN INC
 805 Liberty Lane West Carrollton, OH 45449, U S A
 Phone (513) 847-6200 Fax (513) 847-6277
YASKAWA ELECTRIC EUROPE GmbH
 Niederhöchstädter Straße 73, 61476 Kronberg-Oberhochstadt, Germany
 Phone (06173) 9380 Telex 415660 YASE D Fax (06173) 68421
YASKAWA ELÉTRICO DO BRASIL COMÉRCIO LTDA
 Rua Conde Do Pirhal 8-5º, Andar Sala 51 CEP 01501-São Paulo-SP, Brasil
 Phone (011) 35-1911 Fax (011) 37-7375
YASKAWA ELECTRIC (SINGAPORE) PTE LTD
 CPF Bldg, 79 Robinson Road # 13-05, Singapore 0106, SINGAPORE
 Phone 2217-530 Telex (87) 24890 YASKAWA RS Fax 224-5854
YATEC ENGINEERING CORPORATION
 Shen Hsiang Tang Sung Chiang Building 10F 146 Sung Chiang Road, Taipei, Taiwan
 Phone (02) 563-0010 Fax (02)567-4677



YASKAWA

YASKAWA ELECTRIC CORPORATION