

ACS800

efesotomasyon.com

Firmware Manual

ACS800 Pump Control Application Program 7.2 (+N687)

The ABB logo is located in the bottom right corner of the page. It consists of the letters 'ABB' in a bold, black, sans-serif font. The letters are closely spaced and have a slightly stylized appearance.

efesotomasyon.com

ACS800 Pump Control
Application Program 7.2

Firmware Manual

3AFE68478952 REV C
EN
EFFECTIVE: 2010-04-26

Table of contents

efesotomasyon.com

Table of contents

Introduction to this manual

Chapter overview	11
Compatibility	11
Safety instructions	11
Reader	11
Contents	11
Related Publications	12

Start-up; and control through the I/O

Chapter overview	13
How to start-up the drive	13
How to control the drive through the I/O interface	17
How to perform the ID Run	18
ID Run Procedure	18

Control panel

Chapter overview	21
Overview of the panel	21
Panel operation mode keys and displays	22
Status row	22
Drive control with the panel	23
How to start, stop and change direction	23
How to set speed reference	24
Actual signal display mode	25
How to select actual signals to the display	25
How to display the full name of the actual signals	26
How to view and reset the fault history	26
How to display and reset an active fault	27
About the fault history	27
Parameter mode	28
How to select a parameter and change the value	28
Function mode	29
How to upload data from a drive to the panel	30
How to download data from the panel to a drive	31
How to set the contrast of the display	32
Drive selection mode	33
How to select a drive and change its panel link ID number	33
Reading and entering packed boolean values on the display	34

Program features

Chapter overview	35
Local control vs. external control	35
Local control	35
External control	36
Settings	36
Diagnostics	36
Block diagram: start, stop, direction source for EXT1	37
Block diagram: reference source for EXT1	37
Reference types and processing	38
Settings	38
Diagnostics	38
Programmable analogue inputs	39
Update cycles in the Pump Control Application Program	39
Settings	39
Diagnostics	39
Programmable analogue outputs	40
Update cycles in the Pump Control Application Program	40
Settings	40
Diagnostics	40
Programmable digital inputs	41
Update cycles in the Pump Control Application Program	41
Settings	41
Diagnostics	41
Programmable relay outputs	42
Update cycles in the Pump Control Application Program	42
Settings	42
Diagnostics	42
Actual signals	43
Settings	43
Diagnostics	43
Pump/Fan control	44
Settings	44
Diagnostics	44
Process PI control	45
Settings	45
Diagnostics	45
Sleep function for process PI control	46
Example: Sleep function for a PI controlled pressure boost pump	46
Settings	46
Diagnostics	46
Multipump control	47
Settings	47
Level control	48
Settings	48
Flow calculation	49
Settings	49
Diagnostics	49
Anti-jam function	49

Settings	49
Motor identification	50
Settings	50
Power loss ride-through	50
Automatic Start	51
Settings	51
DC Magnetising	51
Settings	51
Flux Braking	52
Settings	52
Flux Optimization	53
Settings	53
Acceleration and deceleration ramps	53
Settings	53
Critical frequencies	53
Settings	53
Constant frequencies	53
Settings	53
Speed controller tuning	54
Settings	54
Diagnostics	54
Speed control performance figures	55
Torque control performance figures	55
Scalar control	56
Settings	56
IR compensation for a scalar controlled drive	56
Settings	56
Hexagonal motor flux	57
Settings	57
Programmable protection functions	57
AI<Min	57
Panel Loss	57
External Fault	57
Motor Thermal Protection	58
Pressure monitoring	59
Stall Protection	59
Underload Protection	59
Motor Phase Loss	59
Earth Fault Protection	60
Communication Fault	60
Preprogrammed Faults	60
Overcurrent	60
DC overvoltage	60
DC undervoltage	60
Drive temperature	60
Short circuit	61
Input phase loss	61
Ambient temperature	61
Overfrequency	61
Internal fault	61

Operation limits	61
Settings	61
Power limit	61
Automatic resets	62
Settings	62
Supervisions	62
Settings	62
Diagnostics	62
Parameter lock	62
Settings	62
Adaptive Programming using function blocks	63

Application macros

Chapter overview	65
Overview of macros	65
Multipump macro	66
PFC TRAD macro	67
Operation diagram	68
Default control connections	69
Level control macro	70
Hand/Auto macro	71
Operation diagram	71
Default control connections	72
User macros	73

Actual signals and parameters

Chapter overview	75
Terms and abbreviations	75
01 ACTUAL SIGNALS	76
02 ACTUAL SIGNALS	78
03 INTERNAL DATA	78
05 PFC WORDS	79
09 ACTUAL SIGNALS	79
10 START/STOP/DIR	81
11 REFERENCE SELECT	82
12 CONSTANT FREQ	85
13 ANALOGUE INPUTS	86
14 RELAY OUTPUTS	89
15 ANALOGUE OUTPUTS	94
16 SYSTEM CTR INPUT	97
20 LIMITS	99
21 START/STOP	100
22 ACCEL/DECEL	102
23 SPEED CTRL	104
25 CRITICAL FREQ	105
26 MOTOR CONTROL	105
30 FAULT FUNCTIONS	106
31 AUTOMATIC RESET	113

32 SUPERVISION	113
33 INFORMATION	115
40 PI-CONTROLLER	115
41 PFC-CONTROL 1	119
42 PFC-CONTROL 2	122
43 SLEEP FUNCTION	128
44 PFC PROTECTION	132
45 FLOWCONTROL	138
46 ANTI JAM	142
47 LEVEL CONTROL	144
49 ENERGY OPT	148
51 COMM MOD DATA	148
52 STANDARD MODBUS	149
60 MASTER-FOLLOWER	149
65 SHARE IO	156
70 DDCS CONTROL	157
83 ADAPT PROG CTRL	157
84 ADAPTIVE PROGRAM	159
85 USER CONSTANTS	160
90 D SET REC ADDR	161
92 D SET TR ADDR	162
95 HARDWARE SPECIFI	163
96 ANALOGUE OUTPUTS	163
98 OPTION MODULES	166
99 START-UP DATA	167

Fault tracing

Chapter overview	171
Safety	171
Warning and fault indications	171
How to reset	171
Fault history	171
Warning messages generated by the drive	172
Warning messages generated by the control panel	175
Fault messages generated by the drive	176

Pump control application examples

Overview	181
2-pump station with 1 drive	182
Sheet 1 of 3	183
Sheet 2 of 3	184
Sheet 3 of 3 (Pressure sensor connection examples)	185
Multipump configuration with 2 (or more) drives	186
Wiring diagram	186
Optical fibre connections	187
Level control configuration with 2 drives	188
Wiring diagram	188
Pump station remote-controlled through the Internet	189

Fieldbus control

Chapter overview	191
System overview	191
Setting up communication through a fieldbus adapter module	192
Control through the Standard Modbus Link	194
Setting up an Advant Fieldbus 100 (AF 100) connection	196
Drive control parameters	198
The fieldbus control interface	201
The Control Word and the Status Word	202
References	202
Actual values	202
Block diagram: Control data input from fieldbus (for type Nxxx fieldbus adapters)	203
Block diagram: Actual value selection for fieldbus (for type Nxxx fieldbus adapters)	204
Communication profiles	205
ABB Drives communication profile	205
CSA 2.8/3.0 communication profile	209
Diverse status, fault, alarm and limit words	210

Analogue extension module

Chapter overview	219
Speed control through the analogue extension module	219
Basic checks	219
Settings of the analogue extension module and the drive	219
Parameter settings: bipolar input in basic speed control	220

Additional data: actual signals and parameters

Chapter overview	221
Terms and abbreviations	221
Fieldbus addresses	221
Rxxx adapter modules (such as RPBA-01, RDNA-01, etc.)	221
Nxxx adapter modules (such as NPBA-12, NDNA-02, etc.)	221
Actual signals	222
Parameters	225

Further information

Product and service inquiries	235
Product training	235
Providing feedback on ABB Drives manuals	235
Document library on the Internet	235

Introduction to this manual

Chapter overview

This chapter includes a description of the contents of the manual. In addition, it contains information about the compatibility, safety, intended audience, and related publications.

Compatibility

This manual is compatible with the ACS800 Pump Control Application Program version 7.2 (firmware package version AHXR72xx – see parameter [33.01](#)).

Safety instructions

Follow all safety instructions delivered with the drive.

- Read the **complete safety instructions** before you install, commission, or use the drive. The complete safety instructions are given at the beginning of the Hardware Manual.
- Read the **software function specific warnings and notes** before changing the default settings of a function. For each function, the warnings and notes are given in this manual in the subsection describing the related user-adjustable parameters.

Reader

The reader of the manual is expected to know the standard electrical wiring practices, electronic components, and electrical schematic symbols.

Contents

The manual consists of the following chapters:

- *Start-up; and control through the I/O* instructs in setting up the application program, and how to start, stop and regulate the speed of the drive.
- *Control panel* gives instructions for using the panel.
- *Program features* contains the feature descriptions and the reference lists of the user settings and diagnostic signals.
- *Application macros* contains a short description of each macro together with a connection diagram.
- *Actual signals and parameters* describes the actual signals and parameters of the drive.
- *Fault tracing* lists the warning and fault messages with the possible causes and remedies.

- *Fieldbus control* describes the communication through the serial communication links.
- *Pump control application examples* presents an existing two-pump PFC application.
- *Analogue extension module* describes the communication between the drive and an RAIO analogue I/O extension module (optional).
- *Additional data: actual signals and parameters* contains more information on the actual signals and parameters.

Related Publications

In addition to this manual, the ACS800 user documentation includes the following manuals:

- Hardware manuals
- Several user's manuals for the optional devices for the ACS800.

Start-up; and control through the I/O

efesotomasyon.com

Chapter overview

The chapter instructs how to:

- do the start-up
- start, stop, change the direction of rotation, and adjust the speed of the motor through the I/O interface
- perform an Identification Run for the drive.





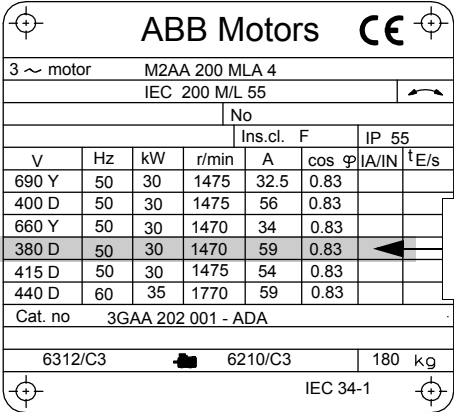

How to start-up the drive

A step-by-step instruction for starting up the drive follows. Before you begin, ensure you have the motor nameplate data at hand.

Note: Before beginning the start-up, ensure that all active interlock inputs (if any) are ON at the digital I/O terminals of the RMIO board of the drive. See the chapter [Actual signals and parameters](#), parameter 42.04.

SAFETY		
	<p>The start-up may only be carried out by a qualified electrician.</p> <p>The safety instructions must be followed during the start-up procedure. See the appropriate hardware manual for safety instructions.</p>	
<input type="checkbox"/>	Check the installation. See the installation checklist in the appropriate hardware/installation manual.	
<input type="checkbox"/>	<p>Check that the starting of the motor does not cause any danger.</p> <p>De-couple the driven machine if:</p> <ul style="list-style-type: none"> - there is a risk of damage in case of incorrect direction of rotation, or - a Standard ID Run needs to be performed during the drive start-up. (ID Run is essential only in applications which require the ultimate in motor control accuracy.) 	
POWER-UP		
<input type="checkbox"/>	<p>Apply mains power. The control panel first shows the panel identification data ...</p> <p>... then the Identification Display of the drive ...</p>	<pre>CDP312 PANEL Vx.xx ACS800 xx kW ID NUMBER 1</pre>
	<p>... then the Actual Signal Display.</p> <p>Drive set-up can now be started.</p>	<pre>1 -> 0.0 rpm 0 ACT VAL1 0.00 bar CURRENT 0.00 A FREQ 0.00 Hz</pre>

MANUAL START-UP DATA ENTERING (parameter group 99)		
<input type="checkbox"/> Select the language. The general parameter setting procedure is described below. The general parameter setting procedure: - Press PAR to select the Parameter Mode of the panel. - Press the double-arrow keys (▲ or ▼) to scroll the parameter groups. - Press the arrow keys (⬆ or ⬇) to scroll parameters within a group. - Activate the setting of a new value by ENTER . - Change the value by the arrow keys (⬆ or ⬇), fast change by the double-arrow keys (▲ or ▼). - Press ENTER to accept the new value (brackets disappear).	<pre> 1 -> 0.0 Hz O 99 START-UP DATA 01 LANGUAGE ENGLISH 1 -> 0.0 Hz O 99 START-UP DATA 01 LANGUAGE [ENGLISH] </pre>	
<input type="checkbox"/> Select the Application Macro. The general parameter setting procedure is given above.	<pre> 1 -> 0.0 Hz O 99 START-UP DATA 02 APPLICATION MACRO [] </pre>	
<input type="checkbox"/> Select the motor control mode. The general parameter setting procedure is given above. DTC is suitable in most cases. The SCALAR control mode is recommended - for multimotor drives when the number of the motors connected to the drive is variable - when the nominal current of the motor is less than 1/6 of the nominal current of the inverter - when the inverter is used for test purposes with no motor connected.	<pre> 1 -> 0.0 Hz O 99 START-UP DATA 04 MOTOR CTRL MODE [DTC] </pre>	
<input type="checkbox"/> Enter the motor data from the motor nameplate: 	<p>Note: Set the motor data to exactly the same value as on the motor nameplate. For example, if the motor nominal speed is 1440 rpm on the nameplate, setting the value of parameter 99.08 MOTOR NOM SPEED to 1500 rpm results in the wrong operation of the drive.</p>	
<input type="checkbox"/> - motor nominal voltage Allowed range: $1/2 \cdot U_N \dots 2 \cdot U_N$ of ACS800. (U_N refers to the highest voltage in each of the nominal voltage ranges: 415 VAC for 400 VAC units, 500 VAC for 500 VAC units and 690 VAC for 600 VAC units.)	<pre> 1 -> 0.0 Hz O 99 START-UP DATA 05 MOTOR NOM VOLTAGE [] </pre>	
<input type="checkbox"/> - motor nominal current Allowed range: approx. $1/6 \times I_{2hd} \dots 2 \times I_{2hd}$ of ACS800	<pre> 1 -> 0.0 Hz O 99 START-UP DATA 06 MOTOR NOM CURRENT [] </pre>	

	<p>- motor nominal frequency Range: 8 ... 300 Hz</p> <p>- motor nominal speed Range: 1 ... 18000 rpm</p> <p>- motor nominal power Range: 0 ... 9000 kW</p> <p>When the motor data has been entered, a warning appears. It indicates that the motor parameters have been set, and the drive is ready to start the motor identification (ID Magnetisation or ID Run).</p>	<pre> 1 -> 0.0 Hz O 99 START-UP DATA 07 MOTOR NOM FREQ [] 1 -> 0.0 Hz O 99 START-UP DATA 08 MOTOR NOM SPEED [] 1 -> 0.0 Hz O 99 START-UP DATA 09 MOTOR NOM POWER [] 1 -> 0.0 Hz O ** WARNING ** ID MAGN REQ </pre>
<input type="checkbox"/>	<p>Select the motor identification method.</p> <p>The default value NO (ID Magnetisation only) is sufficient for most applications. It is applied in this basic start-up procedure.</p> <p>The ID Run (STANDARD or REDUCED) should be selected instead if:</p> <ul style="list-style-type: none"> - The operation point is near zero speed, and/or - Operation at torque range above the motor nominal torque within a wide speed range and without any measured speed feedback is required. <p>For more information, see the subsection <i>How to perform the ID Run</i> below.</p>	<pre> 1 -> 0.0 Hz O 99 START-UP DATA 10 MOTOR ID RUN [NO] </pre>
IDENTIFICATION MAGNETISATION (with Motor ID Run selection ID MAGN)		
<input type="checkbox"/>	<p>Press the LOC/REM key to change to local control (L shown on the first row).</p> <p>Press the  to start the Identification Magnetisation. The motor is magnetised at zero speed for 20 to 60 s. Two warnings are displayed:</p> <p>The upper warning is displayed while the magnetisation is in progress.</p> <p>The lower warning is displayed after the magnetisation is completed.</p>	<pre> 1 L-> 0.0 Hz I ** WARNING ** ID MAGN 1 L-> 0.0 Hz O ** WARNING ** ID DONE </pre>
DIRECTION OF ROTATION OF THE MOTOR		
<input type="checkbox"/>	<p>Check the direction of rotation of the motor.</p> <ul style="list-style-type: none"> - Press ACT to get the status row visible. - Increase the speed reference from zero to a small value by pressing REF and then the arrow keys (, ,  or ). - Press  to start the motor. - Check that the motor is running in the desired direction. - Stop the motor by pressing . 	<pre> 1 L->[xxx] Hz I ACT VAL1 xxx bar CURRENT xx A FREQ xx Hz </pre>

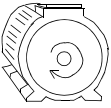
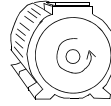
	<p>To change the direction of rotation of the motor:</p> <ul style="list-style-type: none"> - Disconnect mains power from the drive, and wait 5 minutes for the intermediate circuit capacitors to discharge. Measure the voltage between each input terminal (U1, V1 and W1) and earth with a multimeter to ensure that the frequency converter is discharged. - Exchange the position of two motor cable phase conductors at the motor terminals or at the motor connection box. - Verify your work by applying mains power and repeating the check as described above. 	 <p>forward direction</p>  <p>reverse direction</p>
FREQUENCY LIMITS AND ACCELERATION/DECELERATION TIMES		
<input type="checkbox"/>	Set the minimum frequency.	<pre> 1 L-> 0.0 Hz O 20 LIMITS 01 MINIMUM FREQ [] </pre>
<input type="checkbox"/>	Set the maximum frequency.	<pre> 1 L-> 0.0 Hz O 20 LIMITS 02 MAXIMUM FREQ [] </pre>
<input type="checkbox"/>	Set the acceleration time 1. Note: Also set acceleration time 2 if two acceleration times will be used in the application.	<pre> 1 L-> 0.0 rpm O 22 ACCEL/DECEL 02 ACCEL TIME 1 [] </pre>
<input type="checkbox"/>	Set the deceleration time 1. Note: Also set deceleration time 2 if two deceleration times will be used in the application.	<pre> 1 L-> 0.0 rpm O 22 ACCEL/DECEL 03 DECEL TIME 1 [] </pre>
The drive is now ready for use.		

How to control the drive through the I/O interface

The table below instructs how to operate the drive through the digital and analogue inputs, when:

- the motor start-up is performed, and
- the default (PFC TRAD macro) parameter settings are valid.

PRELIMINARY SETTINGS	
Ensure the PFC TRAD macro is active.	See parameter 99.02 .
Ensure the control connections are wired according to the connection diagram given for the PFC TRAD macro.	See the chapter Application macros .
Ensure the drive is in external control mode. Press the LOC/REM key to change between external and local control.	In External control, there is no L visible on the first row of the panel display.
STARTING AND CONTROLLING THE SPEED OF THE MOTOR	
Start by switching digital input DI6 on.	1 -> 0.0 Hz I ACT VAL1 0.00 bar CURRENT 0.00 A FREQ 0.00 Hz
Regulate the speed by adjusting the voltage of analogue input AI1.	1 -> 45.0 Hz I ACT VAL1 10.00 bar CURRENT 80.00 A FREQ 45.00 Hz
STOPPING THE MOTOR	
Switch off digital input DI6.	1 -> 45.0 Hz O ACT VAL1 0.00 bar CURRENT 0.00 A FREQ 0.00 Hz

How to perform the ID Run

The drive performs the ID Magnetisation automatically at the first start. In most applications there is no need to perform a separate ID Run. The ID Run (Standard or Reduced) should be selected if:

- The operation point is near zero speed, and/or
- Operation at torque range above the motor nominal torque within a wide speed range and without any measured speed feedback is required.

The Reduced ID Run is to be performed instead of the Standard if it is not possible to disengage the driven machine from the motor.

ID Run Procedure

Note: If parameter values (Group 10 to 98) are changed before the ID Run, check that the new settings meet the following conditions:

- 20.01 MINIMUM FREQUENCY ≤ 0 Hz.
- 20.02 MAXIMUM FREQUENCY $> 80\%$ of motor rated frequency
- 20.03 MAXIMUM CURRENT $\geq 100\% \cdot I_{hd}$
- 20.04 MAXIMUM TORQUE $> 50\%$

- Ensure that the panel is in the local control mode (L displayed on the status row). Press the **LOC/REM** key to switch between modes.
- Change the ID Run selection to STANDARD or REDUCED.

```
1 L -> 45.0 Hz   O
99 START-UP DATA
10 MOTOR ID RUN
[STANDARD]
```

- Press **ENTER** to verify selection. The following message will be displayed:

```
1 L -> 45.0 Hz   O
ACS800 55 kW
**WARNING**
ID RUN SEL
```

- To start the ID Run, press the  key. The Run Enable signal must be active (see parameter 16.01 RUN ENABLE). With the PFC TRAD macro, the interlocks must be on (see parameter 81.20 INTERLOCKS).

Warning when the ID Run is started	Warning during the ID Run	Warning after a successfully completed ID Run
<pre>1 L -> 45.0 Hz I ACS800 55 kW **WARNING** MOTOR STARTS</pre>	<pre>1 L -> 45.0 Hz I ACS800 55 kW **WARNING** ID RUN</pre>	<pre>1 L -> 45.0 Hz I ACS800 55 kW **WARNING** ID DONE</pre>

In general, it is recommended not to press any control panel keys during the ID Run. However:

- The Motor ID Run can be stopped at any time by pressing the control panel stop key (⏏).
- After the ID Run is started with the start key (▶), it is possible to monitor the actual values by first pressing the **ACT** key and then a double-arrow key (↔).

Control panel

Chapter overview

The chapter describes how to use the control panel CDP 312R.

The same control panel is used with all ACS800 series drives, so the instructions given apply to all ACS800 types. The display examples shown are based on the Standard Application Program; displays produced by other application programs may differ slightly.

Overview of the panel

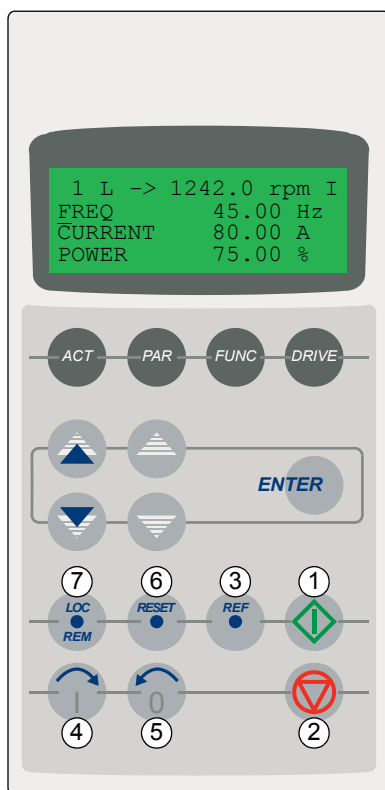

The LCD type display has 4 lines of 20 characters.

The language is selected at start-up (parameter [99.01](#)).

The control panel has four operation modes:

- Actual Signal Display Mode (ACT key)
- Parameter Mode (PAR key)
- Function Mode (FUNC key)
- Drive Selection Mode (DRIVE key)

The use of single arrow keys, double arrow keys and ENTER depend on the operation mode of the panel.

The drive control keys are:





No.	Use
1	Start
2	Stop
3	Activate reference setting
4	Forward direction of rotation
5	Reverse direction of rotation
6	Fault reset
7	Change between Local / Remote (external) control

efesotomasyon.com

Panel operation mode keys and displays

The figure below shows the mode selection keys of the panel, and the basic operations and displays in each mode.





Actual Signal Display Mode

 →   Act. signal / Fault history selection
  Act. signal / Fault message scrolling
ENTER Enter selection mode
ENTER Accept new signal

1 L ->	1242.0 rpm	O
FREQ	45.00 Hz	
CURRENT	80.00 A	
POWER	75.00 %	

← Status row
Actual signal names and values





Parameter Mode

 →   Group selection
 Fast value change
  Parameter selection
 Slow value change
ENTER Enter change mode
ENTER Accept new value

1 L ->	1242.0 rpm	O
10	START/STOP/DIR	
01	EXT1 STRT/STP/DIR	
	DI1,2	

← Status row
Parameter group
Parameter
Parameter value



Function Mode

 →   Row selection
  Page selection
ENTER Function start

1 L ->	1242.0 rpm	O
	Motor Setup	
	Application Macro	
	Speed Control EXT1	

← Status row
List of functions

Drive Selection Mode

 →   Drive selection
 ID number change
ENTER Enter change mode
ENTER Accept new value

ACS 800	75 kW
PFC Application	
AHXR7110	
ID NUMBER	1

← Device type
SW version / application version and ID number

Status row

The figure below describes the status row digits.

Drive ID number	→	1	L	->	1242.0 rpm	I	←	Drive status
Drive control status								I = Running
L = Local control								O = Stopped
R = Remote control								" " = Run disabled
" " = External control								
				↑	↑			
				Direction of rotation	Drive reference			
				-> = Forward				
				<- = Reverse				







Drive control with the panel

The user can control the drive with the panel as follows:

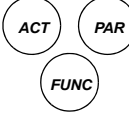

- start, stop, and change direction of the motor
- give the motor speed reference or torque reference
- give a process reference (when the process PID control is active)
- reset the fault and warning messages
- change between local and external drive control.

The panel can be used for control of the drive control always when the drive is under local control and the status row is visible on the display.

How to start, stop and change direction

Step	Action	Press Key	Display
1.	To show the status row.		1 L ->1242.0 rpm I FREQ 45.00 Hz CURRENT 80.00 A POWER 75.00 %
2.	To switch to local control. (only if the drive is not under local control, i.e. there is no L on the first row of the display.)		1 L L ->1242.0 rpm I FREQ 45.00 Hz CURRENT 80.00 A POWER 75.00 %
3.	To stop		1 L L ->1242.0 rpm O FREQ 45.00 Hz CURRENT 80.00 A POWER 75.00 %
4.	To start		1 L L ->1242.0 rpm I FREQ 45.00 Hz CURRENT 80.00 A POWER 75.00 %
5.	To change the direction to reverse.		1 L L <-1242.0 rpm I FREQ 45.00 Hz CURRENT 80.00 A POWER 75.00 %
6.	To change the direction to forward.		1 L L ->1242.0 rpm I FREQ 45.00 Hz CURRENT 80.00 A POWER 75.00 %

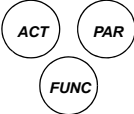
How to set speed reference

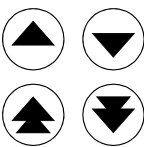
Step	Action	Press Key	Display
1.	To show the status row.		1 ->1242.0 rpm I FREQ 45.00 Hz CURRENT 80.00 A POWER 75.00 %
2.	To switch to local control. (Only if the drive is not under local control, i.e. there is no L on the first row of the display.)		1 L ->1242.0 rpm I FREQ 45.00 Hz CURRENT 80.00 A POWER 75.00 %
3.	To enter the Reference Setting function.		1 L ->[1242.0 rpm] I FREQ 45.00 Hz CURRENT 80.00 A POWER 75.00 %
4.	To change the reference. (slow change) (fast change)		1 L ->[1325.0 rpm] I FREQ 45.00 Hz CURRENT 80.00 A POWER 75.00 %
5.	To save the reference. (The value is stored in the permanent memory; it is restored automatically after power switch-off.)	ENTER	1 L -> 1325.0 rpm I FREQ 45.00 Hz CURRENT 80.00 A POWER 75.00 %











Actual signal display mode

In the Actual Signal Display Mode, the user can:



- show three actual signals on the display at a time
- select the actual signals to display
- view the fault history
- reset the fault history.

The panel enters the Actual Signal Display Mode when the user presses the **ACT** key, or if he does not press any key within one minute.

How to select actual signals to the display









Step	Action	Press key	Display
1.	To enter the Actual Signal Display Mode.		1 L -> 1242.0 rpm I FREQ 45.00 Hz CURRENT 80.00 A POWER 75.00 %
2.	To select a row (a blinking cursor indicates the selected row).	 	1 L -> 1242.0 rpm I FREQ 45.00 Hz CURRENT 80.00 A POWER 75.00 %
3.	To enter the actual signal selection function.	ENTER	1 L -> 1242.0 rpm I 1 ACTUAL SIGNALS 04 CURRENT 80.00 A
4.	To select an actual signal. To change the actual signal group.	   	1 L -> 1242.0 rpm I 1 ACTUAL SIGNALS 05 TORQUE 70.00 %
5.a	To accept the selection and to return to the Actual Signal Display Mode.	ENTER	1 L -> 1242.0 rpm I FREQ 45.00 Hz TORQUE 70.00 % POWER 75.00 %
5.b	To cancel the selection and keep the original selection. The selected keypad mode is entered.	   	1 L -> 1242.0 rpm I FREQ 45.00 Hz CURRENT 80.00 A POWER 75.00 %

How to display the full name of the actual signals

Step	Action	Press key	Display
1.	To display the full name of the three actual signals.	Hold 	1 L -> 1242.0 rpm I F <u>REQUENCY</u> CURRENT POWER
2.	To return to the Actual Signal Display Mode.	Release 	1 L -> 1242.0 rpm I F <u>REQ</u> 45.00 Hz CURRENT 80.00 A POWER 75.00 %

How to view and reset the fault history

Note: The fault history cannot be reset if there are active faults or warnings.

Step	Action	Press key	Display
1.	To enter the Actual Signal Display Mode.		1 L -> 1242.0 rpm I F <u>REQ</u> 45.00 Hz CURRENT 80.00 A POWER 75.00 %
2.	To enter the Fault History Display.	 	1 L -> 1242.0 rpm I 1 LAST FAULT +OVERCURRENT 6451 H 21 MIN 23 S
3.	To select the previous (UP) or the next fault/warning (DOWN). To clear the Fault History.	  	1 L -> 1242.0 rpm I 2 LAST FAULT +OVERVOLTAGE 1121 H 1 MIN 23 S 1 L -> 1242.0 rpm I 2 LAST FAULT H MIN S
4.	To return to the Actual Signal Display Mode.	 	1 L -> 1242.0 rpm I F <u>REQ</u> 45.00 Hz CURRENT 80.00 A POWER 75.00 %

How to display and reset an active fault



WARNING! If an external source for start command is selected and it is ON, the drive will start immediately after fault reset. If the cause of the fault has not been removed, the drive will trip again.

Step	Action	Press Key	Display
1.	To display an active fault.		1 L -> 1242.0 rpm ACS 801 75 kW ** FAULT ** ACS800 TEMP
2.	To reset the fault.		1 L -> 1242.0 rpm 0 FREQ 45.00 Hz CURRENT 80.00 A POWER 75.00 %

About the fault history

The fault history restores information on the latest events (faults, warnings and resets) of the drive. The table below shows how the events are stored in the fault history.

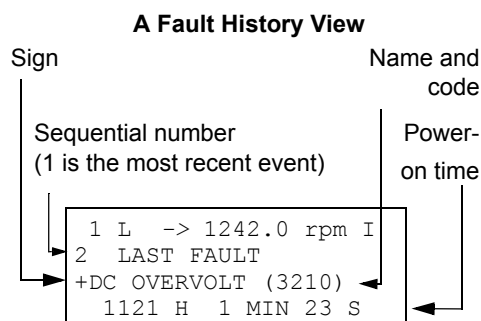

Event	Information on display
Drive detects a fault and generates a fault message	Sequential number of the event and LAST FAULT text. Name of the fault and a "+" sign in front of the name. Total power-on time.
User resets the fault message.	Sequential number of the event and LAST FAULT text. -RESET FAULT text. Total power-on time.
Drive generates a warning message.	Sequential number of the event and LAST WARNING text. Name of the warning and a "+" sign in front of the name. Total power-on time.
Drive deactivates the warning message.	Sequential number of the event and LAST WARNING text. Name of the warning and a "-" sign in front of the name. Total power-on time.













Parameter mode

In the Parameter Mode, the user can:

- view the parameter values
- change the parameter settings.

The panel enters the Parameter Mode when the user presses the **PAR** key.

How to select a parameter and change the value

Step	Action	Press key	Display
1.	To enter the Parameter Mode.		1 L -> 1242.0 rpm O 10 START/STOP/DIR 01 EXT1 STRT/STP/DIR DI1,2
2.	To select a group.	 	1 L -> 1242.0 rpm O 11 REFERENCE SELECT 01 KEYPAD REF SEL REF1 (rpm)
3.	To select a parameter within a group.	 	1 L -> 1242.0 rpm O 11 REFERENCE SELECT 03 EXT REF1 SELECT AI1
4.	To enter the parameter setting function.	ENTER	1 L -> 1242.0 rpm O 11 REFERENCE SELECT 03 EXT REF1 SELECT [AI1]
5.	To change the parameter value. - (slow change for numbers and text) - (fast change for numbers only)	   	1 L -> 1242.0 rpm O 11 REFERENCE SELECT 03 EXT REF1 SELECT [AI2]
6a.	To save the new value.	ENTER	1 L -> 1242.0 rpm O 11 REFERENCE SELECT 03 EXT REF1 SELECT AI2
6b.	To cancel the new setting and keep the original value, press any of the mode selection keys. The selected mode is entered.	   	1 L -> 1242.0 rpm O 11 REFERENCE SELECT 03 EXT REF1 SELECT AI1

Function mode

In the Function Mode, the user can:

- upload the drive parameter values and motor data from the drive to the panel.
- download group 1 to 97 parameter values from the panel to the drive. ¹⁾
- adjust the contrast of the display.

The panel enters the Function Mode when the user presses the **FUNC** key.

¹⁾ The parameter groups 98, 99 and the results of the motor identification are not included by default. The restriction prevents downloading of unsuitable motor data. In special cases it is, however, possible to download all. For more information, please contact your local ABB representative.

How to upload data from a drive to the panel

Note:





- Upload before downloading.
- Ensure the program versions of the destination drive are the same as the versions of the source drive, see parameters [33.01](#) and [33.02](#).
- Before removing the panel from a drive, ensure the panel is in remote operating mode (change with the LOC/REM key).
- Stop the drive before downloading.

Before upload, repeat the following steps in each drive:

- Setup the motors.
- Activate the communication to the optional equipment. (See parameter group [98 OPTION MODULES](#).)





Before upload, do the following in the drive from which the copies are to be taken:

- Set the parameters in groups 10 to 97 as preferred.
- Proceed to the upload sequence (below).











Step	Action	Press Key	Display
1.	Enter the Function Mode.		1 L -> 1242.0 rpm 0 Motor Setup Application Macro Speed Control EXT1
2.	Enter the page that contains the upload, download and contrast functions.		1 L -> 1242.0 rpm 0 UPLOAD <=<= DOWNLOAD =>=> CONTRAST 4
3.	Select the upload function (a flashing cursor indicates the selected function).	 	1 L -> 1242.0 rpm 0 UPLOAD <=<= DOWNLOAD =>=> CONTRAST 4
4.	Enter the upload function.	ENTER	1 L -> 1242.0 rpm 0 UPLOAD <=<=
5.	Switch to external control. (No L on the first row of the display.)		1 -> 1242.0 rpm 0 UPLOAD <=<= DOWNLOAD =>=> CONTRAST 4
6.	Disconnect the panel and reconnect it to the drive into which the data will be downloaded.		

How to download data from the panel to a drive

Consider the notes in section [How to upload data from a drive to the panel](#) above.

Step	Action	Press Key	Display
1.	Connect the panel containing the uploaded data to the drive.		
2.	Ensure the drive is in local control (L shown on the first row of the display). If necessary, press the LOC/REM key to change to local control.		1 L -> 1242.0 rpm I FREQ 45.00 Hz CURRENT 80.00 A POWER 75.00 %
3.	Enter the Function Mode.		1 L -> 1242.0 rpm O Motor Setup Application Macro Speed Control EXT1
4.	Enter the page that contains the upload, download and contrast functions.		1 L -> 1242.0 rpm O UPLOAD <=<= DOWNLOAD =>=> CONTRAST 4
5.	Select the download function (a flashing cursor indicates the selected function).	 	1 L -> 1242.0 rpm O UPLOAD <=<= DOWNLOAD =>=> CONTRAST 4
6.	Start the download.	ENTER	1 L -> 1242.0 rpm O DOWNLOAD =>=>

How to set the contrast of the display

Step	Action	Press Key	Display
1.	Enter the Function Mode.		1 L -> 1242.0 rpm O Motor Setup Application Macro Speed Control EXT1
2.	Enter the page that contains the upload, download and contrast functions.		1 L -> 1242.0 rpm O U <u>P</u> LOAD <=<= D <u>O</u> WNL <u>O</u> AD =>=> C <u>O</u> NTR <u>A</u> ST 4
3.	Select a function (a flashing cursor indicates the selected function).	 	1 L -> 1242.0 rpm O U <u>P</u> LOAD <=<= D <u>O</u> WNL <u>O</u> AD =>=> C <u>O</u> NTR <u>A</u> ST 4
4.	Enter the contrast setting function.	ENTER	1 L -> 1242.0 rpm O C <u>O</u> NTR <u>A</u> ST [4]
5.	Adjust the contrast.	 	1 L -> 1242.0 rpm C <u>O</u> NTR <u>A</u> ST [6]
6.a	Accept the selected value.	ENTER	1 L -> 1242.0 rpm O U <u>P</u> LOAD <=<= D <u>O</u> WNL <u>O</u> AD =>=> C <u>O</u> NTR <u>A</u> ST 6
6.b	Cancel the new setting and retain the original value by pressing any of the mode selection keys. The selected mode is entered.	   	1 L -> 1242.0 rpm I F <u>R</u> EQ 45.00 Hz C <u>U</u> RRE <u>N</u> T 80.00 A P <u>O</u> W <u>E</u> R 75.00 %

Drive selection mode

In normal use the features available in the Drive Selection Mode are not needed; the features are reserved for applications where several drives are connected to one panel link. (For more information, see the *Installation and Start-up Guide for the Panel Bus Connection Interface Module, NBCI*, Code: 3AFY 58919748 [English]).

In the Drive Selection Mode, the user can:



- Select the drive with which the panel communicates through the panel link.
- Change the identification number of a drive connected to the panel link.
- View the status of the drives connected on the panel link.

The panel enters the Drive Selection Mode when the user presses the **DRIVE** key.

Each on-line station must have an individual identification number (ID). By default, the ID number of the drive is 1.

Note: The default ID number setting of the drive should not be changed unless the drive is to be connected to the panel link with other drives on-line.

How to select a drive and change its panel link ID number

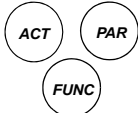
Step	Action	Press key	Display
1.	To enter the Drive Selection Mode.		ACS800 75 kW PFC Application AHXR715B ID NUMBER 1
2.	To select the next drive/view. The ID number of the station is changed by first pressing ENTER (the brackets round the ID number appear) and then adjusting the value with arrow buttons. The new value is accepted with ENTER . The power of the drive must be switched off to validate its new ID number setting. The status display of all devices connected to the Panel Link is shown after the last individual station. If all stations do not fit on the display at once, press the double-arrow up to view the rest of them.		ACS800 75 kW PFC Application AHXR715B ID NUMBER 1 1↻ Status Display Symbols: ↻ = Drive stopped, direction forward ↶ = Drive running, direction reverse F = Drive tripped on a fault
3.	To connect to the last displayed drive and to enter another mode, press one of the mode selection keys. The selected mode is entered.		1 L -> 1242.0 rpm I FREQ 45.00 Hz CURRENT 80.00 A POWER 75.00 %

Reading and entering packed boolean values on the display

Some actual values and parameters are packed boolean, i.e. each individual bit has a defined meaning (explained at the corresponding signal or parameter). On the control panel, packed boolean values are read and entered in hexadecimal format.

In this example, bits 1, 3 and 4 of the packed boolean value are ON:

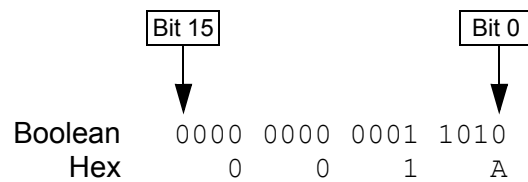

Program features

Chapter overview

The chapter describes program features. For each feature, there is a list of related user settings, actual signals, and fault and warning messages.

Local control vs. external control

The drive can receive start, stop and direction commands and reference values from the control panel or through digital and analogue inputs. An optional fieldbus adapter enables control over an open fieldbus link. A PC equipped with DriveWindow® can also control the drive.

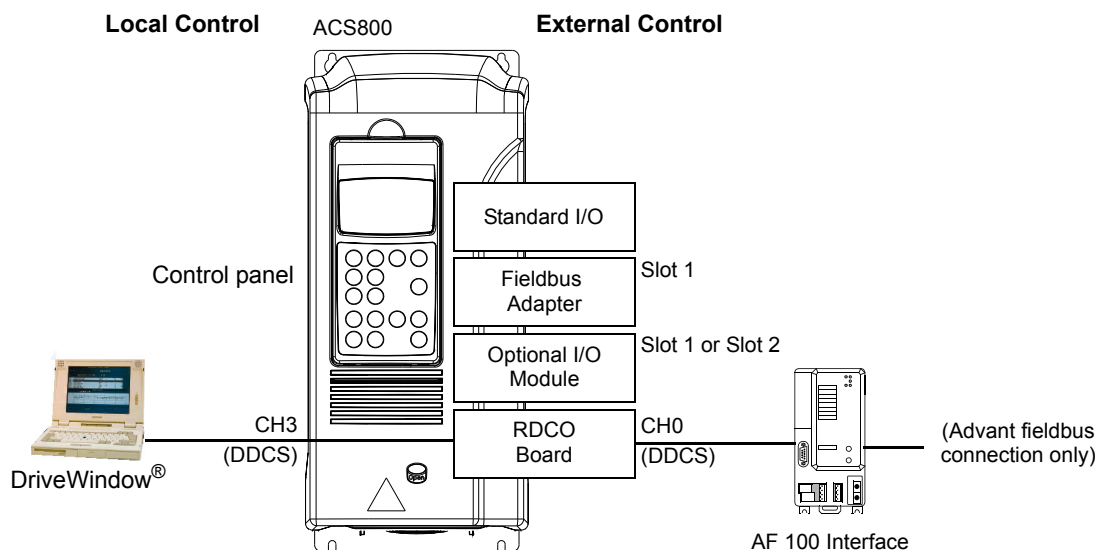

Local control

The control commands are given from the control panel keypad when the drive is in local control. L indicates local control on the panel display.

1 (L) -> 1242 rpm I

The control panel always overrides the external control signal sources when used in local mode.

External control

When the drive is in external control, the commands are given through the standard I/O terminals (digital and analogue inputs), optional I/O extension modules and/or the fieldbus interface. In addition, it is also possible to set the control panel as the source for the external control.

External control is indicated by a blank on the panel display or with an R in those special cases when the panel is defined as a source for external control.



External Control through the Input/
Output terminals, or through the
fieldbus interfaces

External Control by control panel

The user can connect the control signals to two external control locations, EXT1 or EXT2. Depending on the user selection, either one is active at a time.

Settings

Panel key	Additional information
LOC/REM	Selection between local and external control.
Parameter	
11.02	Selection between EXT1 and EXT2.
10.01	Start, stop, direction source for EXT1.
11.03	Reference source for EXT1.
10.02	Start, stop, direction source for EXT2.
11.06	Reference source for EXT2.
Group 98 OPTION MODULES	Activation of the optional I/O and serial communication.

Diagnostics

Actual signals	Additional information
01.11, 01.12	EXT1 reference, EXT2 reference.
03.02	EXT1/EXT2 selection bit in a packed boolean word.

Block diagram: start, stop, direction source for EXT1

The figure below shows the parameters that select the interface for start, stop, and direction for external control location EXT1.

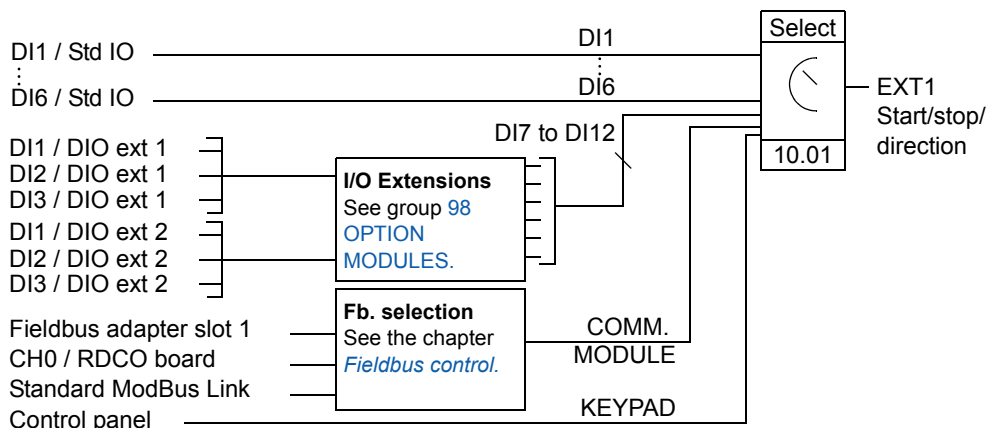

DI1 / Std IO = Digital input DI1 on the standard I/O terminal block
 DI1 / DIO ext 1 = Digital input DI1 on digital I/O extension module 1

Block diagram: reference source for EXT1

The figure below shows the parameters that select the interface for the speed reference of external control location EXT1.

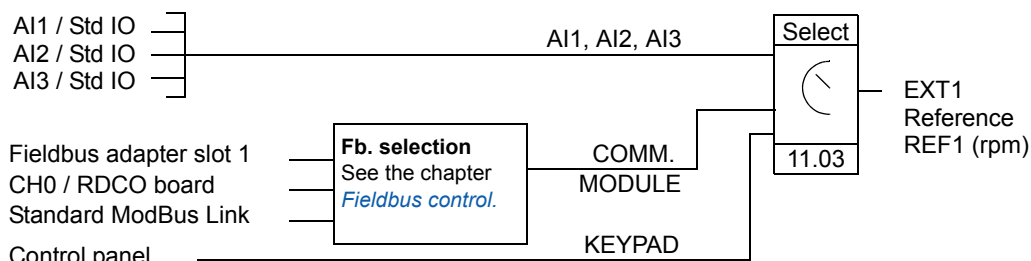

AI1 / Std IO = Analogue input AI1 on the standard I/O terminal block

Reference types and processing

The drive can accept a variety of references in addition to the conventional analogue input signal and control panel signals.

- The drive accepts a bipolar analogue speed reference. This feature allows both the speed and direction to be controlled with a single analogue input. The minimum signal is full speed reversed and the maximum signal is full speed forward.
- The drive can form a reference out of two analogue input signals by using mathematical functions: Addition, subtraction, multiplication, minimum selection, and maximum selection.

It is possible to scale the external reference so that the signal minimum and maximum values correspond to a speed other than the minimum and maximum speed limits.

Settings

Parameter	Additional information
Group 11 REFERENCE SELECT	External reference source, type and scaling.
Group 20 LIMITS	Operating limits.
Group 22 ACCEL/DECEL	Acceleration and deceleration ramps.
Group 32 SUPERVISION	Reference supervision.

Diagnostics

Actual signal	Additional information
01.11, 01.12	Values of external references.
Group 02 ACTUAL SIGNALS	The reference values in different stages of the reference processing chain.
Parameter	
Group 14 RELAY OUTPUTS	Active reference / reference loss through a relay output.
Group 15 ANALOGUE OUTPUTS	Reference value.

Programmable analogue inputs

The drive has three programmable analogue inputs: one voltage input (0/2 to 10 V or -10 to 10 V) and two current inputs (0/4 to 20 mA). Each input can be inverted and filtered, and the maximum and minimum values can be adjusted.

Update cycles in the Pump Control Application Program

Input	Cycle
AI / standard	12 ms
AI / extension	12 ms

Settings

Parameter	Additional information
Group 11 REFERENCE SELECT	AI as a reference source.
Group 13 ANALOGUE INPUTS	Processing of the standard inputs.
30.01	Supervision of AI loss.
Group 41 PFC-CONTROL 1	AI as a PI process control reference.
Group 44 PFC PROTECTION	Pressure monitoring through AI.
Group 45 FLOWCONTROL	Pressure measurement for flow calculation.
Group 47 LEVEL CONTROL	Level measurement through AI.
98.06	Activation of optional analogue inputs.
98.08	Optional AI signal type definition (bipolar or unipolar).
98.09	Optional AI signal type definition (bipolar or unipolar).

Diagnostics

Actual value	Additional information
01.18, 01.19, 01.20	Values of standard inputs.
01.38, 01.39	Value of optional inputs.

Programmable analogue outputs

Two programmable current outputs (0/4 to 20 mA) are available as standard, and two further outputs can be added by using an optional analogue I/O extension module. Analogue output signals can be inverted and filtered.

The analogue output signals can be proportional to motor speed, process speed (scaled motor speed), output frequency, output current, motor torque, motor power, etc.

It is possible to write a value to an analogue output through a serial communication link.

Update cycles in the Pump Control Application Program

Output	Cycle
AO / standard	24 ms
AO / extension	24 ms

Settings

Parameter	Additional information
Group 15 ANALOGUE OUTPUTS	AO value selection and processing (standard outputs).
30.20	Operation of an externally controlled AO in a communication break.
30.22	Supervision of the use of optional AO.
Group 96 ANALOGUE OUTPUTS	Optional AO value selection and processing.
Group 98 OPTION MODULES	Activation of optional I/O.

Diagnostics

Actual value	Additional information
01.22, 01.23	Values of the standard outputs.
01.28, 01.29	Values of the optional outputs.

Programmable digital inputs

The drive has six programmable digital inputs (DI1 to DI6) as standard. Six extra inputs (DI7 to DI12) are available if optional digital I/O extension modules are used.

Update cycles in the Pump Control Application Program

Input	Cycle
DI / standard	12 ms
DI / extension	12 ms

Settings

Parameter	Additional information
Group 10 START/STOP/DIR	DI as start, stop, direction.
Group 11 REFERENCE SELECT	DI in reference selection.
Group 12 CONSTANT FREQ	DI in constant frequency selection.
Group 16 SYSTEM CTR INPUT	DI as external Run Enable, fault reset or user macro change signal.
22.01	DI as acceleration and deceleration ramp selection signal.
30.03	DI as external fault source.
30.05	DI in motor overtemperature supervision function.
43.01	DI as sleep function activation signal (in PI process control).
98.03 ... 98.04	Activation of the optional digital I/O extension modules.

Diagnostics

Actual value	Additional information
01.17	Values of the standard digital inputs.
01.40	Values of the optional digital inputs.
Fault	
I/O COMM ERR (7000)	Communication loss to I/O.

Programmable relay outputs

As standard there are three programmable relay outputs. Four outputs can be added by using two optional digital I/O extension modules. By means of a parameter setting it is possible to choose which information to indicate through the relay output: ready, running, fault, warning, motor stall, etc.

It is possible to write a value to a relay output through a serial communication link.

Update cycles in the Pump Control Application Program

Output	Cycle
RO / standard	100 ms
RO / extension	100 ms

Settings

Parameter	Additional information
Group 14 RELAY OUTPUTS	RO value selections and operation times.
30.21	Operation of an externally controlled relay output on a communication break.
Group 98 OPTION MODULES	Activation of optional relay outputs.

Diagnostics

Actual value	Additional information
01.21	Standard relay output states.
01.41	Optional relay output states.

Actual signals

Several actual signals are available:

- Drive output frequency, current, voltage and power
- Motor speed and torque
- Mains voltage and intermediate circuit DC voltage
- Active control location (Local, EXT1 or EXT2)
- Reference values
- Drive temperature
- Operating time counter (h), kWh counter
- Digital I/O and Analogue I/O status
- PI controller actual values (if the PFC TRAD macro is selected)
- Calculated flow
- Level measurement

Three signals can be shown simultaneously on the control panel display. It is also possible to read the values through the serial communication link or through the analogue outputs.

Settings

Parameter	Additional information
Group 15 ANALOGUE OUTPUTS	Selection of an actual signal to an analogue output.
Group 92 D SET TR ADDR	Selection of an actual signal to a dataset (serial communication).

Diagnostics

Actual value	Additional information
Group 01 ACTUAL SIGNALS ... 09 ACTUAL SIGNALS	Lists of actual signals.

Pump/Fan control

The PFC TRAD (Pump and fan control) application macro is specially designed for multimotor pumping (or compressor, etc.) stations. While directly controlling one motor, the drive is able to start additional, direct-on-line motors whenever a higher capacity is needed. There is an Autochange function to alternate between the pumps so all pumps have an equal duty time, and the Interlocks function enables the drive to detect if any of the pumps are unavailable (e.g. switched off for maintenance) so the next available pump is started instead.

See the chapter [Pump control application examples](#). See also the chapter [Application macros](#), section [PFC TRAD macro](#), and the parameter groups listed below.

Settings

Parameter	Additional information
Group 14 RELAY OUTPUTS	Selection of digital outputs for starting and stopping of motors.
Group 41 PFC-CONTROL 1	Process reference selection, set-up of auxiliary motor start/stop frequencies.
Group 42 PFC-CONTROL 2	Set-up of auxiliary motors, start delays, Interlocks function and automatic motor alternation (Autochange function).
Group 44 PFC PROTECTION	Set-up of PFC protections (pressure monitoring).

Diagnostics

Actual value	Additional information
01.17 , 01.40	Status of digital inputs.
01.21 , 01.41	Status of relay outputs.
01.42	Time since latest Autochange.

Process PI control

There is a built-in PI controller in the drive. The controller can be used to control process variables such as pressure, flow or fluid level.

When the process PI control is activated, a process reference (setpoint) is connected to the drive instead of a speed reference. An actual value (process feedback) is also brought back to the drive. The process PI control adjusts the drive speed in order to keep the measured process quantity (actual value) at the desired level (reference).

The block diagram below right illustrates the process PI control.

The figure on the left shows an application example: The controller adjusts the speed of a pressure boost pump according to the measured pressure and the set pressure reference.

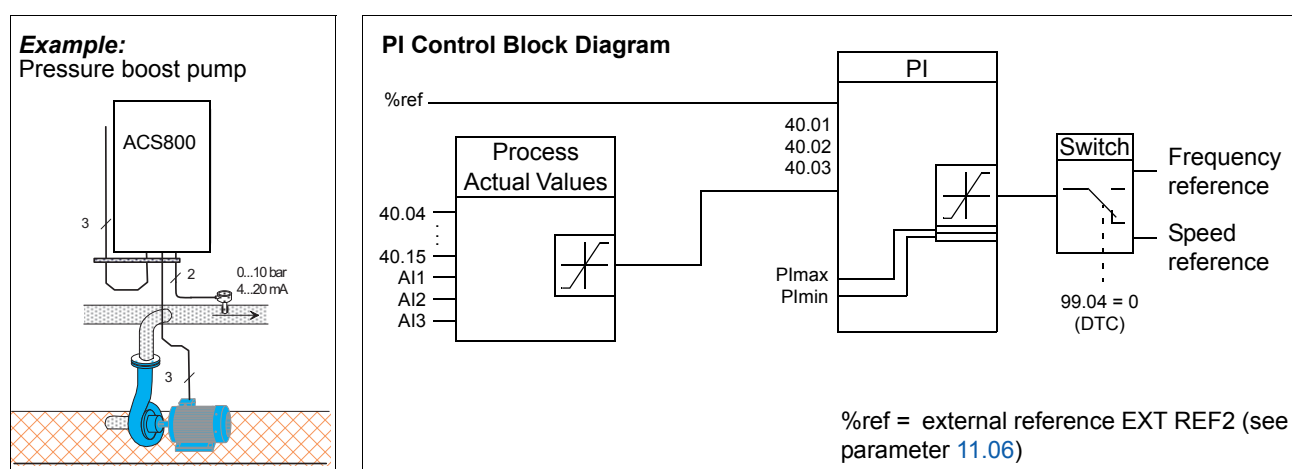

Settings

Parameter	Purpose
99.02	Application macro selection.
Group 40 PI-CONTROLLER	The settings of the process PI controller.
32.09 to 32.14	The supervision limits for the process reference REF2 and the variables ACT1 and ACT2.

Diagnostics

Actual Signals	Purpose
01.12, 01.24, 01.25 and 01.26	PI process controller reference, actual values and error value.
Group 14 RELAY OUTPUTS	Supervision limit exceeded indication through a relay output.
Group 15 ANALOGUE OUTPUTS	PI process controller values through standard analogue outputs.

Sleep function for process PI control

The block diagram below illustrates the sleep function enable/disable logic.

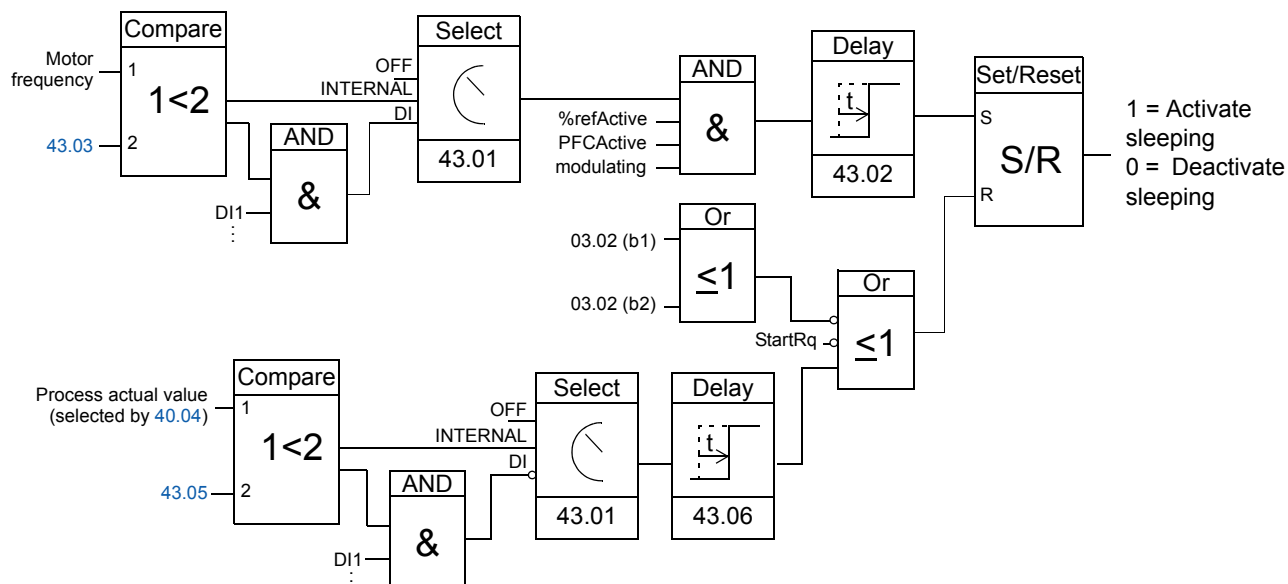

Motor freq.: Drive output frequency
 %refActive: The % reference (EXT REF2) is in use. See Parameter 11.02.
 PFCActive: 99.02 is PFC TRAD
 modulating: The inverter IGBT control is operating

Example: Sleep function for a PI controlled pressure boost pump

Water consumption falls at night. As a consequence, the PI process controller decreases the motor speed. However, due to natural losses in the pipes and the low efficiency of the centrifugal pump at low speeds, the motor does not stop but keeps rotating. The sleep function detects the slow rotation, and stops the unnecessary pumping after the sleep delay has passed. The drive shifts into sleep mode, still monitoring the pressure. The pumping restarts when the pressure falls under the allowed minimum level and the wake-up delay has passed.

Settings

Parameter	Additional information
99.02	Application macro activation (MULTIMASTER or PFC TRAD).
Group 43 SLEEP FUNCTION	Sleep function settings.

Diagnostics

Warning SLEEP MODE on the panel display.

Multipump control

The Multipump macro is designed for pumping stations that consist of multiple pumps, each controlled by a separate drive. The drives can be connected so that in case of a pump failure or maintenance action on one drive, the remaining drives continue operation.

The following diagram illustrates the Multipump logic.

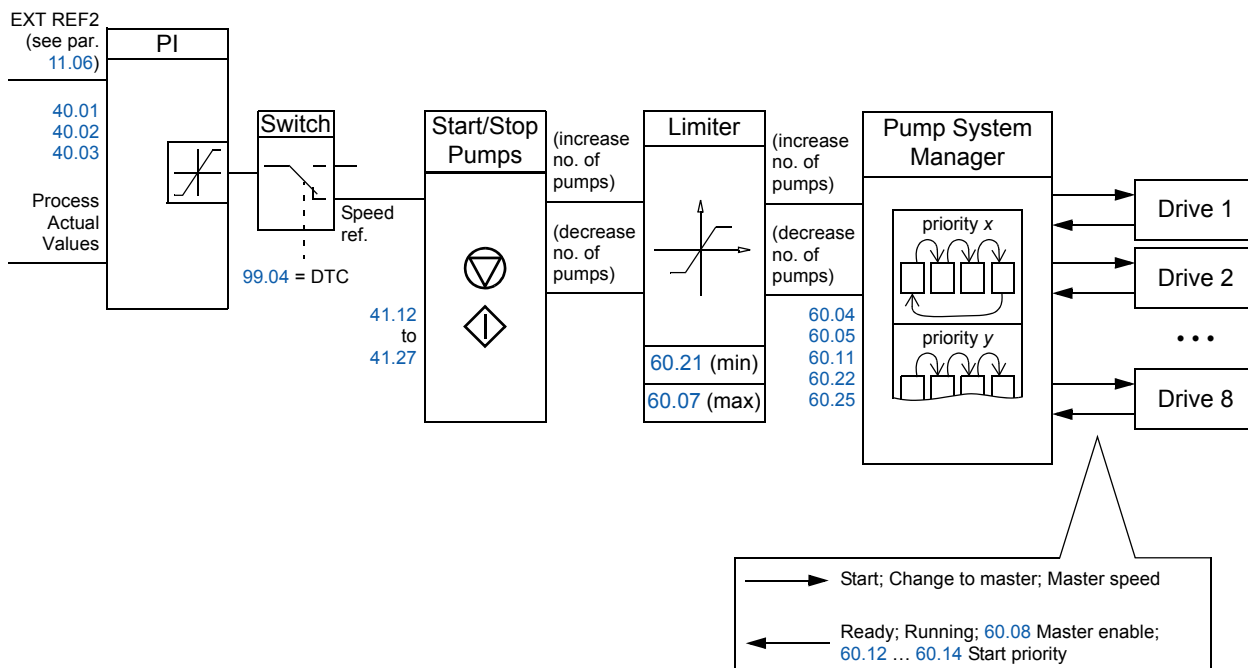

For more information, see the chapter [Application macros](#).

Settings

Parameter	Purpose
99.02	Application macro selection.
99.04	Motor control mode selection (must be set to DTC).
Group 60 MASTER-FOLLOWER	Settings for the Multipump macro.

Level control

The Level control macro is designed for controlling a station of 1 to 8 pumps that is used for either emptying or filling a container. A fluid level sensor is connected to an analogue input. The measurement is used to start one or more pumps whenever necessary.

The following diagram illustrates the Level control logic.

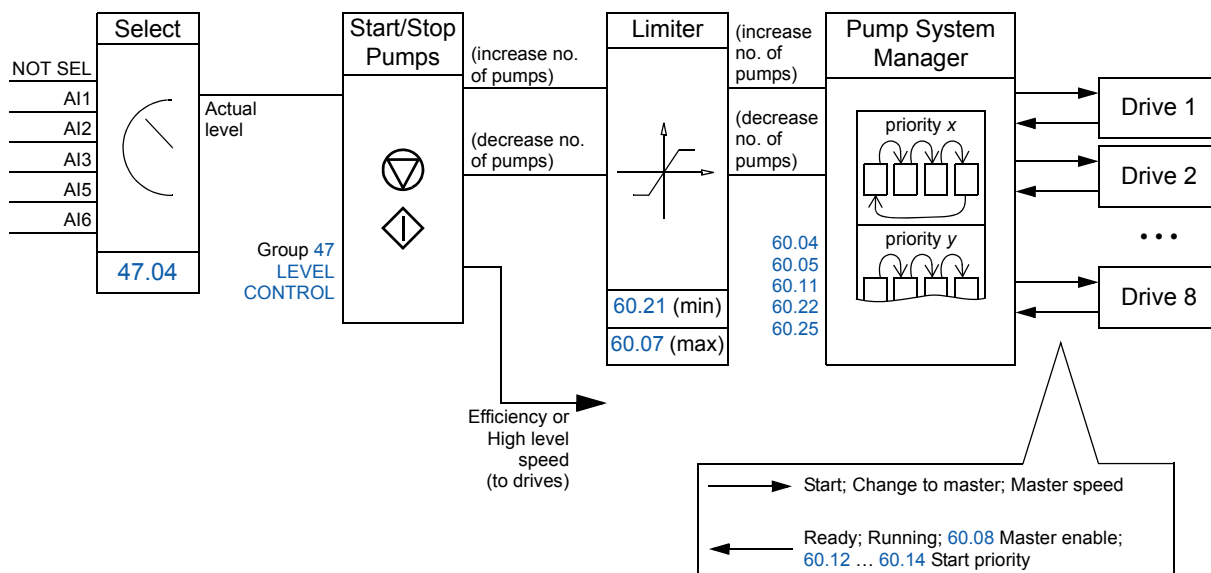

Settings

Parameter	Purpose
99.02	Application macro selection.
Group 47 LEVEL CONTROL	Settings for the Level control macro.
Group 60 MASTER-FOLLOWER	Settings for Multipump control.

Flow calculation

The application program contains a function that enables reasonably accurate (approximately $\pm 5 \dots 10\%$) calculation of flow without the installation of a separate flow meter. The flow is calculated on the basis of parameter data such as pump inlet and outlet diameters, height difference of pressure sensors, and pump characteristics.

Note: The flow calculation function is not to be used for invoicing purposes.

Note: The flow calculation function cannot be used outside the normal operating range of the pump.

Settings

Parameter	Purpose
Group 45 FLOWCONTROL	Settings for the flow calculation function.

Diagnostics

Actual Signals	Purpose
05.11 and 05.12	Flow counters
05.13	Difference between selected inlet and outlet pressures

Anti-jam function

The Anti-jam function can be used for preventing solids from building up on pump impellers. The Anti-jam procedure consists of a programmable sequence of forward and reverse runs of the pump, effectively shaking off any residue on the impeller. This is especially useful with booster and wastewater pumps.

The function can be timed to occur at a suitable time without interrupting the pumping duty cycle.

Settings

Parameter	Purpose
Group 46 ANTI JAM	Settings for the Anti-jam function.

Motor identification

The performance of Direct Torque Control is based on an accurate motor model determined during the motor start-up.

A motor Identification Magnetisation is automatically done the first time the start command is given. During this first start-up, the motor is magnetised at zero speed for several seconds to allow the motor model to be created. This identification method is suitable for most applications.

In demanding applications, a separate Identification Run can be performed.

Settings

Parameter [99.10](#).

Power loss ride-through

If the incoming supply voltage is cut off, the drive will continue to operate by utilising the kinetic energy of the rotating motor. The drive will be fully operational as long as the motor rotates and generates energy to the drive. The drive can continue the operation after the break if the main contactor remained closed.

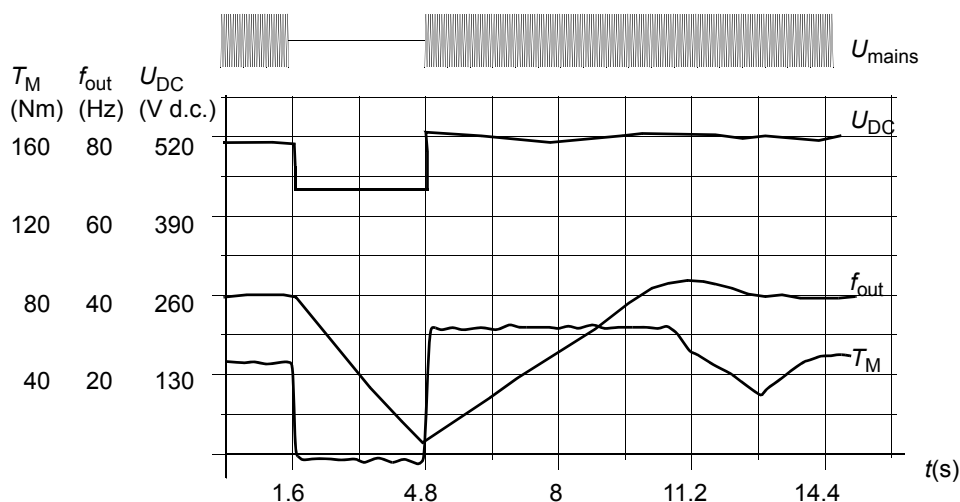

U_{DC} = Intermediate circuit voltage of the drive, f_{out} = output frequency of the drive, T_M = Motor torque

Loss of supply voltage at nominal load ($f_{out} = 40$ Hz). The intermediate circuit DC voltage drops to the minimum limit. The controller keeps the voltage steady as long as the mains is switched off. The drive runs the motor in generator mode. The motor speed falls but the drive is operational as long as the motor has enough kinetic energy.

Note: Cabinet assembled units equipped with main contactor option have a “hold circuit” that keeps the contactor control circuit closed during a short supply break. The allowed duration of the break is adjustable. The factory setting is 5 seconds.

Automatic Start

Since the drive can detect the state of the motor within a few milliseconds, the starting is immediate under all conditions. There is no restart delay. E.g. the starting of turbining pumps or windmilling fans is easy.

Settings

Parameter [21.01](#).

DC Magnetising

When DC Magnetising is activated, the drive automatically magnetises the motor before starting. This feature guarantees the highest possible breakaway torque, up to 200% of motor nominal torque. By adjusting the premagnetising time, it is possible to synchronise the motor start and e.g. a mechanical brake release. The Automatic Start feature and DC Magnetising cannot be activated at the same time.

Settings

Parameters [21.01](#) and [21.02](#).

Flux Braking

The drive can provide greater deceleration by raising the level of magnetisation in the motor. By increasing the motor flux, the energy generated by the motor during braking can be converted to motor thermal energy. This feature is useful in motor power ranges below 15 kW.

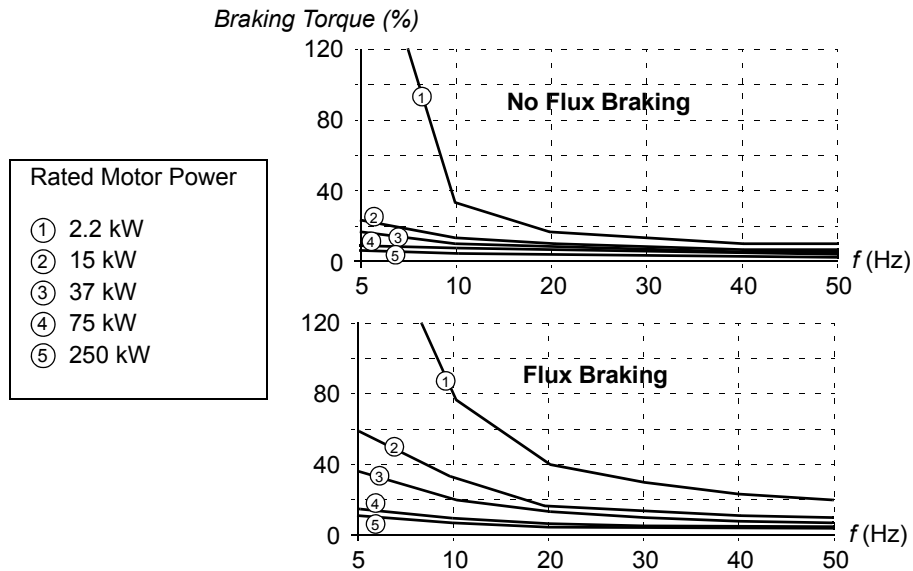
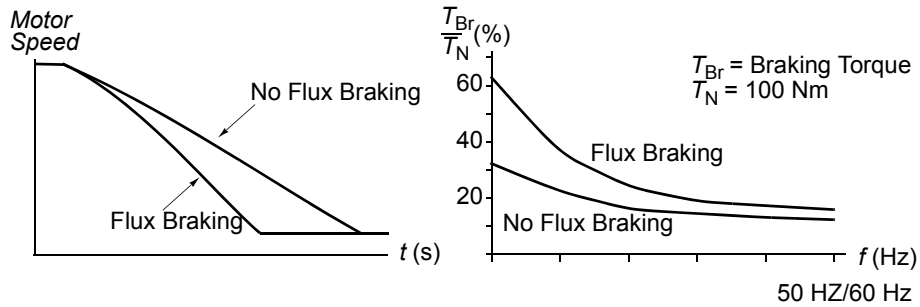

The drive monitors the motor status continuously, also during Flux Braking. Therefore, Flux Braking can be used both for stopping the motor and for changing the speed. The other benefits of Flux Braking are:

- The braking starts immediately after a stop command is given. The function does not need to wait for the flux reduction before it can start the braking.
- The cooling of the motor is efficient. The stator current of the motor increases during the Flux Braking, not the rotor current. The stator cools much more efficiently than the rotor.

Settings

Parameter [26.02](#).

Flux Optimization

Flux Optimization reduces the total energy consumption and motor noise level when the drive operates below the nominal load. The total efficiency (motor and the drive) can be improved by 1% to 10%, depending on the load torque and speed.

Settings

Parameter [26.01](#).

Acceleration and deceleration ramps

Two user-selectable acceleration and deceleration ramps are available. It is possible to adjust the acceleration/deceleration times and the ramp shape. Switching between the two ramps can be controlled via a digital input.

The available ramp shape alternatives are Linear and S-curve.

Linear: Suitable for drives requiring steady or slow acceleration/deceleration.

S-curve: Ideal for conveyors carrying fragile loads, or other applications where a smooth transition is required when changing the speed.

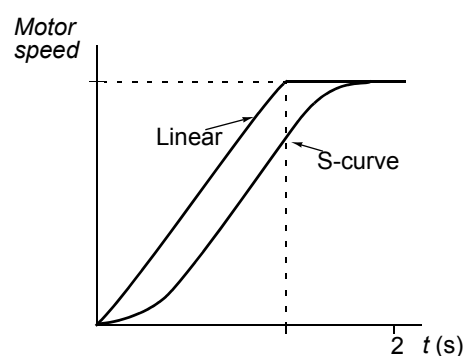

Settings

Parameter group [22 ACCEL/DECEL](#).

Critical frequencies

A critical frequencies function is available for applications where it is necessary to avoid certain motor frequencies or frequency bands because of e.g. mechanical resonance problems.

Settings

Parameter group [25 CRITICAL FREQ.](#)

Constant frequencies

It is possible to predefine three constant frequencies. Constant frequencies are selectable through digital inputs. Constant frequency activation overrides the drive frequency reference.

Settings

Parameter group [12 CONSTANT FREQ.](#)

Speed controller tuning

During the motor identification, the speed controller is automatically tuned. It is, however, possible to manually adjust the controller gain, integration time and derivation time, or let the drive perform a separate speed controller Autotune Run. In Autotune Run, the speed controller is tuned based on the load and inertia of the motor and the machine. The figure below shows speed responses at a speed reference step (typically, 1 to 20%).

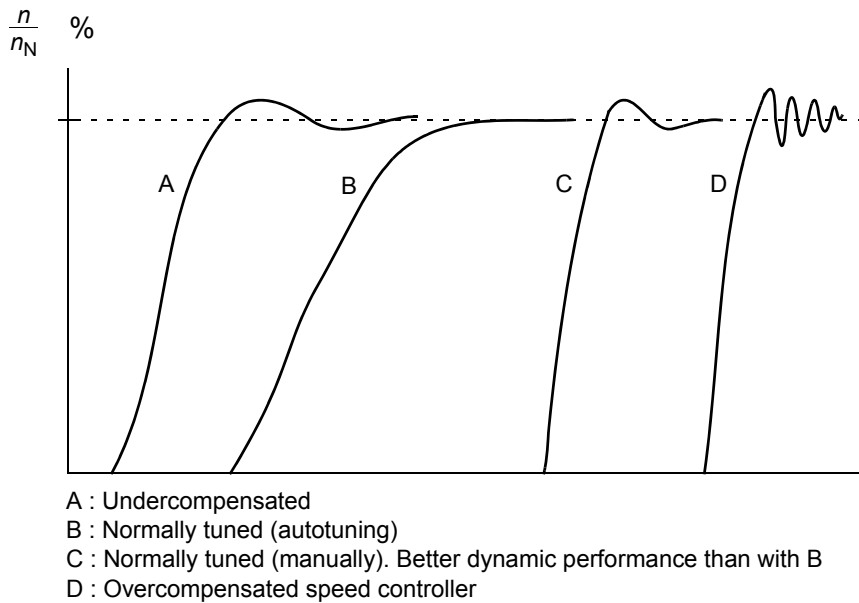

The figure below is a simplified block diagram of the speed controller. The controller output is the reference for the torque controller.

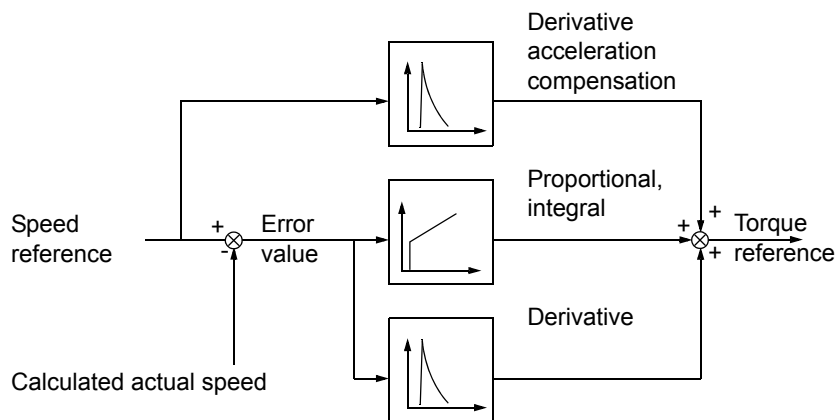

Settings

Parameter group [23 SPEED CTRL](#) and [20 LIMITS](#).

Diagnostics

Actual signal [01.02](#).

Speed control performance figures

The table below shows typical performance figures for speed control when Direct Torque Control is used.

Speed Control	No Pulse Encoder	With Pulse Encoder
Static speed error, % of n_N	± 0.1 to 0.5% (10% of nominal slip)	$\pm 0.01\%$
Dynamic speed error	0.4% sec.*	0.1% sec.*

*Dynamic speed error depends on speed controller tuning.

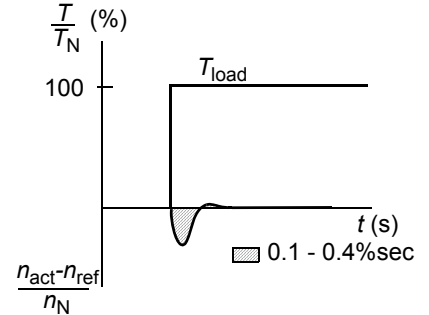

T_N = rated motor torque
 n_N = rated motor speed
 n_{act} = actual speed
 n_{ref} = speed reference

Torque control performance figures

The drive can perform precise torque control without any speed feedback from the motor shaft. The table below shows typical performance figures for torque control, when Direct Torque Control is used.

Torque Control	No Pulse Encoder	With Pulse Encoder
Linearity error	$\pm 4\%$ *	$\pm 3\%$
Repeatability error	$\pm 3\%$ *	$\pm 1\%$
Torque rise time	1 to 5 ms	1 to 5 ms

*When operated around zero frequency, the error may be greater.

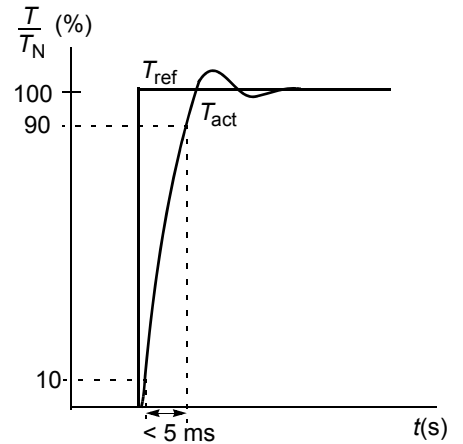

T_N = rated motor torque
 T_{ref} = torque reference
 T_{act} = actual torque

Scalar control

It is possible to select Scalar Control as the motor control method instead of Direct Torque Control (DTC). In the Scalar Control mode, the drive is controlled with a frequency reference. The outstanding performance of the default motor control method, Direct Torque Control, is not achieved in Scalar Control.

It is recommended to activate the Scalar Control mode in the following special applications:

- In multimotor drives: 1) if the load is not equally shared between the motors, 2) if the motors are of different sizes, or 3) if the motors are going to be changed after the motor identification
- If the nominal current of the motor is less than 1/6 of the nominal output current of the drive
- If the drive is used without a motor connected (e.g. for test purposes)
- The drive runs a medium voltage motor via a step-up transformer.

In the Scalar Control mode, some standard features are not available.

Settings

Parameter [99.04](#).

IR compensation for a scalar controlled drive

IR Compensation is active only when the motor control mode is Scalar (see the section [Scalar control](#) above). When IR Compensation is activated, the drive gives an extra voltage boost to the motor at low speeds. IR Compensation is useful in applications that require high breakaway torque. In Direct Torque Control, no IR Compensation is possible/needed.

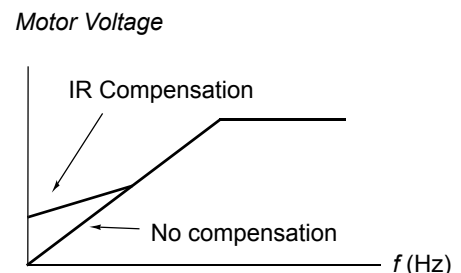

Settings

Parameter [26.03](#).

Hexagonal motor flux

Typically the drive controls the motor flux in such a way that the rotating flux vector follows a circular pattern. This is ideal in most applications. When operated above the field weakening point (FWP, typically 50 or 60 Hz), it is, however, not possible to reach 100% of the output voltage. The peak load capacity of the drive is lower than with the full voltage.

If hexagonal flux control is selected, the motor flux is controlled along a circular pattern below the field weakening point, and along a hexagonal pattern in the field weakening range. The applied pattern is changed gradually as the frequency increases from 100% to 120% of the FWP. Using the hexagonal flux pattern, the maximum output voltage can be reached; The peak load capacity is higher than with the circular flux pattern but the continuous load capacity is lower in the frequency range of FWP to $1.6 \times \text{FWP}$, due to increased losses.

Settings

Parameter [26.04](#).

Programmable protection functions

AI<Min

AI<Min function defines the drive operation if an analogue input signal falls below the preset minimum limit.

Settings

Parameter [30.01](#).

Panel Loss

Panel Loss function defines the operation of the drive if the control panel selected as control location for the drive stops communicating.

Settings

Parameter [30.02](#).

External Fault

External Faults can be supervised by defining one digital input as a source for an external fault indication signal.

Settings

Parameter [30.03](#).

Motor Thermal Protection

The motor can be protected against overheating by activating the Motor Thermal Protection function and by selecting one of the motor thermal protection modes available.

The Motor Thermal Protection modes are based either on a motor temperature thermal model or on an overtemperature indication from a motor thermistor.

Motor temperature thermal model

The drive calculates the temperature of the motor on the basis of the following assumptions:

- 1) The motor is in the ambient temperature of 30 °C when power is applied to the drive.
- 2) Motor temperature is calculated using either the user-adjustable or automatically calculated motor thermal time and motor load curve (see the figures below). The load curve should be adjusted in case the ambient temperature exceeds 30 °C.

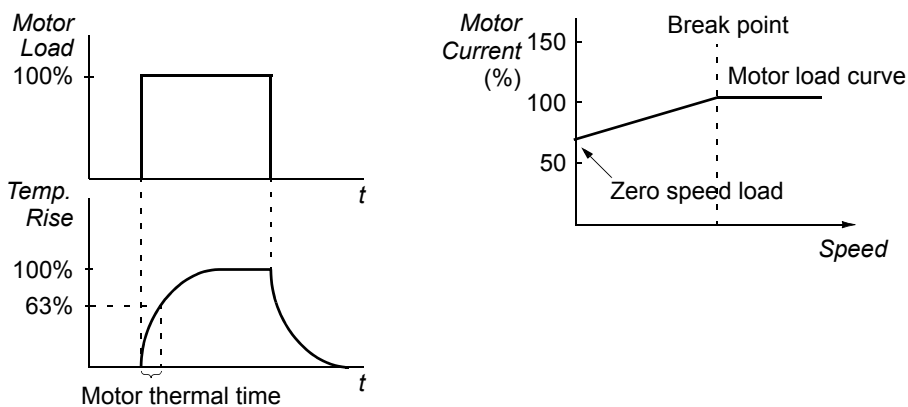

Use of the motor thermistor

It is possible to detect motor overtemperature by connecting a motor thermistor (PTC) between the +24 VDC voltage supply offered by the drive and digital input DI6. In normal motor operation temperature, the thermistor resistance should be less than 1.5 kohm (current 5 mA). The drive stops the motor and gives a fault indication if the thermistor resistance exceeds 4 kohm. The installation must meet the regulations for protecting against contact.

Settings

Parameters [30.04](#) to [30.09](#).

Pressure monitoring

The Pump Control application program contains protective functions for two-level analogue or single-level digital pressure monitoring of both the inlet and the outlet of the pump (or compressor, etc.).

In analogue monitoring, whenever the pressure being monitored meets the first limit, the drive indicates a warning, trips on a fault, or starts to follow a pre-set reference. When the second limit is met, the drive either stops or produces a fault.

In digital pressure monitoring, one limit is observed. Whenever the limit is met, the drive indicates a warning, trips on a fault, or starts to follow a pre-set reference.

Settings

Parameter group [44 PFC PROTECTION](#).

Stall Protection

The drive protects the motor in a stall situation. It is possible to adjust the supervision limits (frequency, time) and choose how the drive reacts to the motor stall condition (warning indication / fault indication & stop the drive / no reaction).

Settings

Parameters [30.10](#) to [30.12](#).

Underload Protection

Loss of motor load may indicate a process malfunction. The drive provides an underload function to protect the machinery and process in such a serious fault condition. Supervision limits - underload curve and underload time - can be chosen as well as the action taken by the drive upon the underload condition (warning indication / fault indication & stop the drive / no reaction).

Settings

Parameters [30.13](#) to [30.15](#).

Motor Phase Loss

The Phase Loss function monitors the status of the motor cable connection. The function is useful especially during the motor start: the drive detects if any of the motor phases is not connected and refuses to start. The Phase Loss function also supervises the motor connection status during normal operation.

Settings

Parameter [30.16](#).

Earth Fault Protection

The Earth Fault Protection detects earth faults in the motor or motor cable.

The Earth Fault protection is based on earth leakage current measurement with a summation current transformer at the output of the converter.

- An earth fault in the mains does not activate the protection.
- In an earthed (grounded) supply, the protection activates in 200 microseconds.
- In floating mains, the mains capacitance should be 1 microfarad or more.
- The capacitive currents due to screened copper motor cables up to 300 metres do not activate the protection.

Settings

Parameter [30.17](#).

Communication Fault

The Communication Fault function supervises the communication between the drive and an external control device (e.g. a fieldbus adapter module).

Settings

Parameters [30.19](#) to [30.22](#).

Preprogrammed Faults

Overcurrent

The overcurrent trip limit for the drive is $1.65 \cdot I_{\max}$ to $2.17 \cdot I_{\max}$ depending on drive type.

DC overvoltage

The DC overvoltage trip limit is $1.3 \cdot U_{1\max}$, where $U_{1\max}$ is the maximum value of the mains voltage range. For 400 V units, $U_{1\max}$ is 415 V. For 500 V units, $U_{1\max}$ is 500 V. For 690 V units, $U_{1\max}$ is 690 V. The actual voltage in the intermediate circuit corresponding to the mains voltage trip level is 728 VDC for 400 V units, 877 VDC for 500 V units, and 1210 VDC for 690 V units.

DC undervoltage

The DC undervoltage trip limit is $0.65 \cdot U_{1\min}$, where $U_{1\min}$ is the minimum value of the mains voltage range. For 400 V and 500 V units, $U_{1\min}$ is 380 V. For 690 V units, $U_{1\min}$ is 525 V. The actual voltage in the intermediate circuit corresponding to the mains voltage trip level is 334 VDC for 400 V and 500 V units, and 461 VDC for 690 V units.

Drive temperature

The drive supervises the inverter module temperature. If the inverter module temperature exceeds 115 °C, a warning is given. The temperature trip level is 125 °C.

Short circuit

There are separate protection circuits for supervising the motor cable and the inverter short circuits. If a short circuit occurs, the drive will not start and a fault indication is given.

Input phase loss

Input phase loss protection circuits supervise the mains cable connection status by detecting intermediate circuit ripple. If a phase is lost, the ripple increases. The drive is stopped and a fault indication is given if the ripple exceeds 13%.

Ambient temperature

The drive will not start if the ambient temperature is below -5 to 0 °C or above 73 to 82 °C (the exact limits vary within the given ranges depending on drive type).

Overfrequency

If the drive output frequency exceeds the preset level, the drive is stopped and a fault indication is given. The preset level is 50 Hz over the operating range absolute maximum speed limit (Direct Torque Control mode active) or frequency limit (Scalar Control active).

Internal fault

If the drive detects an internal fault the drive is stopped and a fault indication is given.

Operation limits

ACS800 has adjustable limits for speed, current (maximum), torque (maximum) and DC voltage.

Settings

Parameter group [20 LIMITS](#).

Power limit

The maximum allowed motor power is $1.5 \cdot P_{hd}$. If the limit is exceeded, the motor torque is automatically restricted. The function protects the input bridge of the drive against overload.

Automatic resets

The drive can automatically reset itself after overcurrent, overvoltage, undervoltage and “analogue input below a minimum” faults. The Automatic Resets must be activated by the user.

Settings

Parameter group [31 AUTOMATIC RESET](#).

Supervisions

The drive monitors whether certain user selectable variables are within the user-defined limits. The user may set limits for speed, current etc.

Settings

Parameter group [32 SUPERVISION](#).

Diagnostics

Actual Signals	Additional information
03.04	Supervision limit indicating bits in a packed boolean word.
Group 14 RELAY OUTPUTS	Supervision limit indication through a relay output.

Parameter lock

The user can prevent parameter adjustment by activating the parameter lock.

Settings

Parameters [16.02](#) and [16.03](#).

Adaptive Programming using function blocks

Conventionally, the user can control the operation of the drive by parameters. Each parameter has a fixed set of choices or a setting range. The parameters make the programming easy, but the choices are limited. The user cannot customise the operation any further. The Adaptive Program makes freer customising possible without the need of a special programming tool or language:

- The program is built of standard function blocks included in the drive application program.
- The control panel is the programming tool.
- The user can document the program by drawing it on block diagram template sheets.

The maximum size of the Adaptive Program is 15 function blocks. The program may consist of several separate functions.

For more information, see *Application Guide for Adaptive Program* (code: 3AFE64527274 [English]).

Application macros

Chapter overview

This chapter describes the intended use, operation and the default control connections of the standard application macros. It also describes how to save a user macro, and how to recall it.

Overview of macros

Application macros are preprogrammed parameter sets. While starting up the drive, the user can select one of the macros by parameter [99.02](#).

There are four standard macros and two user macros. The table below contains a summary of the macros and describes suitable applications.

Macro	Suitable Applications
Multipump	Pump station with up to 8 drives. At a time, one of the drives is master, the others are followers. The master status can be rotated throughout the drives.
PFC TRAD	Pump/fan/compressor station with one to five parallel pumps. One of the pumps is controlled by a drive, the others are direct-on-line and switched on and off by a relay system.
Level control	Control of fluid level in a tank.
Hand/Auto	Speed control applications. Switching between two external control devices is possible.
User	The user can save the customised standard macro i.e. the parameter settings including group 99, and the results of the motor identification into the permanent memory, and recall the data at a later time. Two user macros are essential when switching between two different motors is required.

Multipump macro

The Multipump macro is designed for pumping stations that consist of multiple pumps, each controlled by a separate drive.

The configuration supports redundancy so that in case of a pump failure or maintenance action on one drive, the remaining drives continue operation. The drives communicate with each other through an NDBU-95 DDCS branching unit. (At the expense of redundancy, it is also possible to connect the drives in a ring without using a branching unit.) The external controller (PLC) is distributed to the digital and analogue inputs on multiple drives as shown below. It is also possible to distribute the analogue input values from two selected drives to the other drives via the fibre optic link (see parameter group [65 SHARE IO](#)).

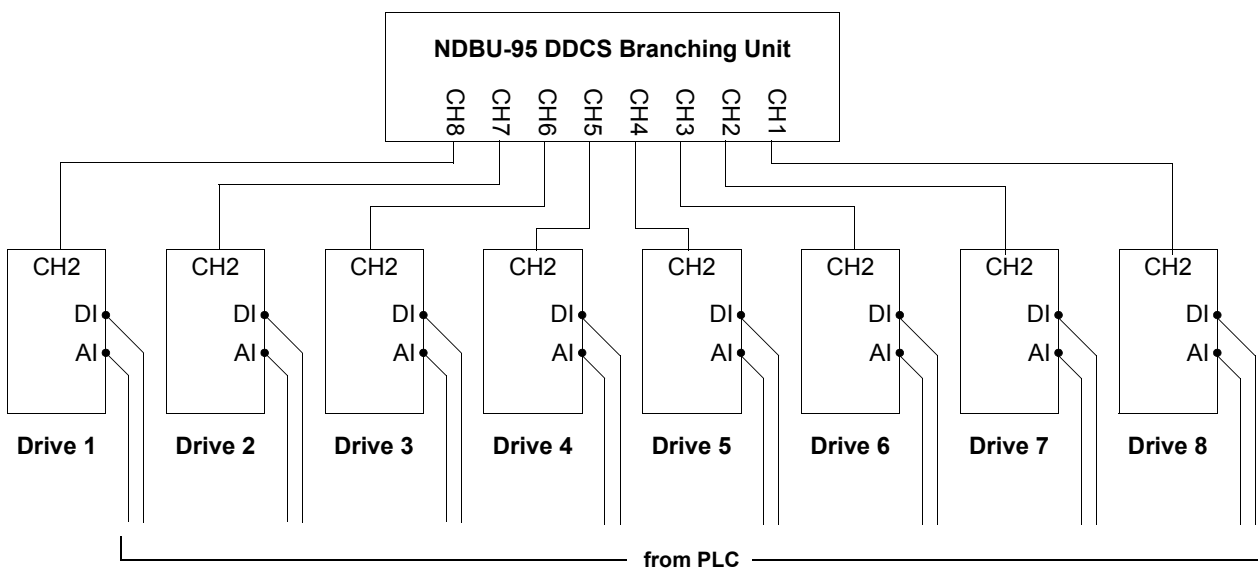

The Multipump functionality is active when the Multipump macro (parameter [99.02](#)) and external control location EXT2 (parameter group [10 START/STOP/DIR](#)) are selected. The process reference can be either external or internal (parameter group [41 PFC-CONTROL 1](#)).

The Multipump macro has three modes selectable by a parameter.

In master-regulated operation, when the load increases, the master's output frequency increases. After the master has reached full speed, other drives are started one by one so that the drive that was started last acts as the master. Follower drives are run either at a pre-set speed (i.e. at the optimal operating point of the pump) or at the same speed as the master. In both these modes, drives can be prioritised so that the one with the highest priority is the first to be started.

In direct follower operation, all drives run in synchronisation with the master. This mode can be used in time-critical applications or for testing of the pump installation.

An example connection diagram for a Multipump configuration is presented on page [186](#).

PFC TRAD macro

The PFC TRAD (“traditional” pump and fan control) macro can operate a pump (or fan or compressor) station with one to five parallel pumps. The control principle of a two-pump station is as follows:

- The motor of pump 1 is connected to the drive. The capacity of the pump is controlled by varying the motor speed.
- The motor of pump 2 is connected direct-on-line. The pump can be switched on and off by the drive when necessary.
- The process reference and actual value are fed to the PI controller included in the PFC TRAD macro. The PI controller adjusts the speed (frequency) of pump 1 such that the process actual value follows the reference. When the frequency reference of the process PI controller exceeds the limit set by the user, the PFC TRAD macro automatically starts pump 2. When the frequency falls below the limit set by the user, the PFC TRAD macro automatically stops pump 2.
- Using the digital inputs of the drive, an interlocking function can be implemented; the PFC TRAD macro detects if a pump is switched off and starts the other pump instead.
- The PFC TRAD macro makes automatic pump alternation possible (not in use in the example below) so both pumps have an equal duty time. For more information on the alternation system and other useful features such as the Sleep function, Constant reference value, Reference steps and Regulator by-pass, see the chapter [Actual signals and parameters](#) (Groups 41 and 42).

By default, the drive receives process reference (setpoint) through analogue input AI1, process actual value through analogue input AI2 and Start/Stop commands through digital input DI6. The interlocks are connected to digital input DI2 (Motor 1) and digital input DI3 (Motor 2).

The default output signals are given through analogue output AO1 (frequency) and AO2 (actual value of the process PI controller). Relay outputs are used to control auxiliary motors.

If the Control Panel is in Local control mode (“L” visible on the first row of the display), the drive follows the frequency reference given from the Panel. The automatic PFC logic is bypassed: no process PI controller is in use and the direct-on-line motors are not started.

Operation diagram

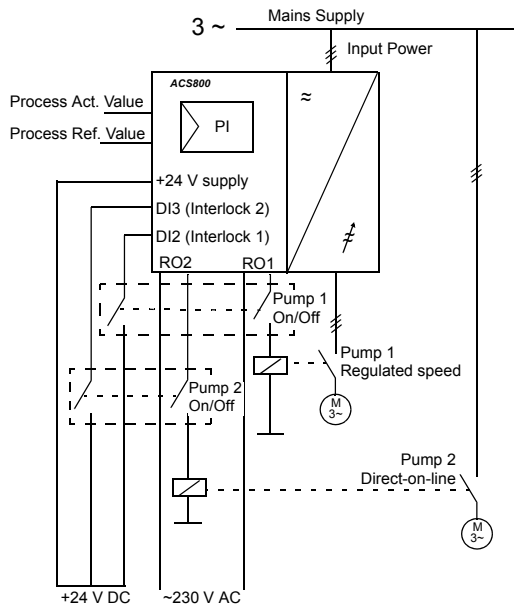

```

1 L -> 45.0 Hz I
ACTUAL V 10.0 bar
FREQUENC 45.00 Hz
DI6-1 ST 1100010
    
```

Reference, Start/Stop, and Direction commands are given from the Control Panel. To change to External, press **LOC REM**.

```

1 -> 45.0 Hz I
ACTUAL V 10.0 bar
FREQUENC 45.00 Hz
MOTOR SP 1350.0 rpm
    
```

Reference is read from analogue input AI2. Start/Stop commands are given through digital input DI6.

Note: By default, automatic pump alternation is not in use.

Default control connections

The figure below shows the external control connections for the PFC TRAD macro. The markings of the standard I/O terminals on the RMIO board are shown.

See the wiring diagram on page 185 for sensor connection instructions.

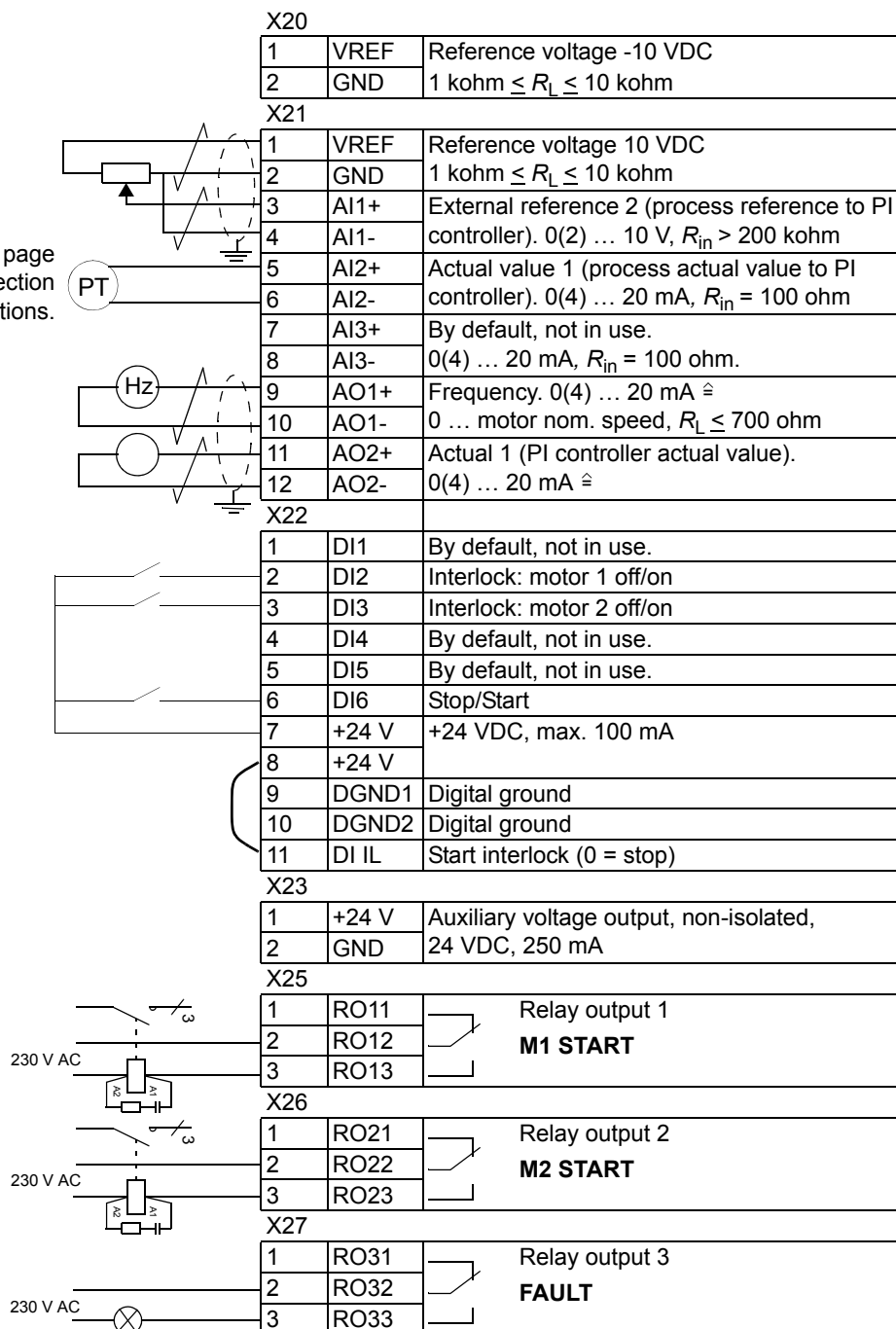

Level control macro

The Level control macro is designed for controlling a station of 1 to 8 pumps that is used for either emptying or filling a container. A fluid level sensor is connected to an analogue input.

The Level control functionality is active when the Level control macro (parameter [99.02](#)) and external control location EXT2 (parameter group [10 START/STOP/DIR](#)) are selected. The process reference can be either external or internal (parameter group [41 PFC-CONTROL 1](#)). The start levels for the pumps (as well as the warning levels) are set by parameters in group [47 LEVEL CONTROL](#).

At any time, one of the drives acts as master. The master status can be rotated throughout all the drives (using the Autochange function), or one drive can be a fixed master. The start/stop level settings of the master are the ones in effect.

The following drawing represents a station with three submersible pumps in emptying mode. Each pump has a pre-defined start level, and more pumps are started as the level in the container rises.

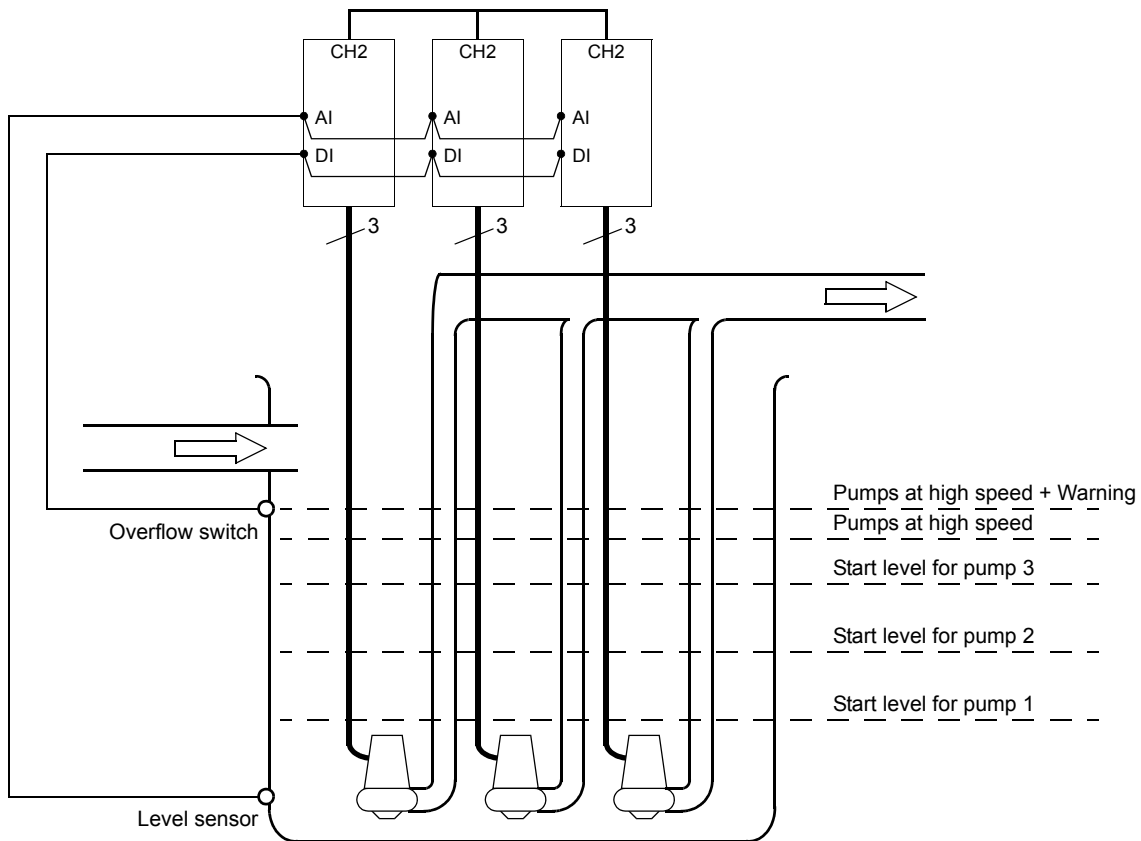

An example connection diagram is presented on page [188](#).

Hand/Auto macro

Start/Stop and Direction commands and reference settings can be given from one of two external control locations, EXT1 (Hand) or EXT2 (Auto). The Start/Stop/Direction commands of EXT1 (Hand) are connected to digital input DI1, and the reference signal is connected to analogue input AI1. The Start/Stop/Direction commands of EXT2 (Auto) are connected to digital input DI6, and the reference signal is connected to analogue input AI2. The selection between EXT1 and EXT2 is dependent on the status of digital input DI5. The drive is frequency-controlled.

The frequency reference and Start/Stop and Direction commands can also be given from the control panel.

The frequency reference in Auto Control (EXT2) is given as a percentage of the maximum frequency of the drive.

Two analogue and three relay output signals are available on terminal blocks. The default signals on the display of the control panel are MOTOR SPEED FILT, FREQUENCY and EXTERNAL REF 2.

Operation diagram

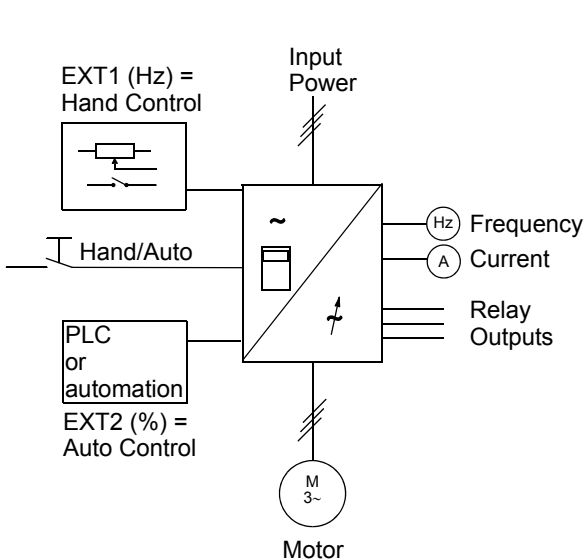

1 L	->	45.0 Hz I
MOTOR SP		1350.00 rpm
FREQUENC		45.00 Hz
EXTERNAL		15.5 %

Local control: Reference, Start/Stop commands are given from the Control Panel. To change to External, press **LOC REM**.

1	->	45.0 Hz I
MOTOR SP		1350.00 rpm
FREQUENC		45.00 Hz
EXTERNAL		15.5%

External control (Hand): Reference is read from analogue input AI1. Start/Stop commands are given through digital input DI1.

Default control connections

The figure below shows the external control connections for the Hand/Auto macro. The markings of the standard I/O terminals on the RMIO board are shown.

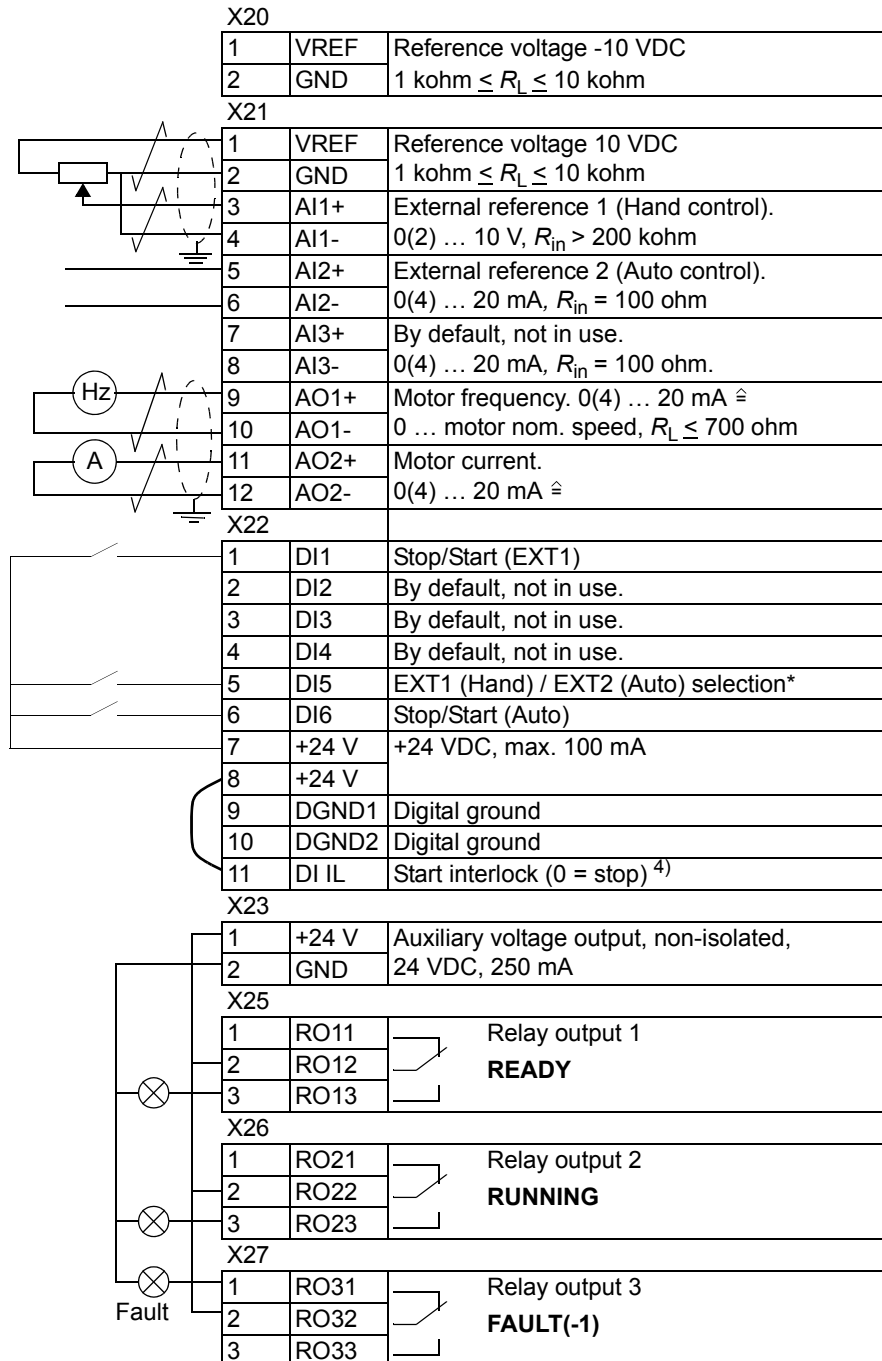

User macros

In addition to the standard application macros, it is possible to create two user macros. The user macro allows the user to save the parameter settings including Group 99, and the results of the motor identification into the permanent memory, and recall the data at a later time. The panel reference and the control location setting (Local or Remote) are also saved.

To create User Macro 1:

- Adjust the parameters. Perform the motor identification if not performed yet.
- Save the parameter settings and the results of the motor identification by changing parameter [99.02](#) to USER 1 SAVE (press ENTER). The storing takes approximately 20 to 60 seconds.

To recall the user macro:

- Change parameter [99.02](#) to USER 1 LOAD.
- Press **ENTER** to load.

The user macro can also be switched via digital inputs (see parameter [16.05](#)).

Note: User macro load restores also the motor settings in group [99 START-UP DATA](#) and the results of the motor identification. Check that the settings correspond to the motor used.

Example: The user can switch the drive between two motors without having to adjust the motor parameters and to repeat the motor identification every time the motor is changed. The user needs only to adjust the settings and perform the motor identification once for both motors and then to save the data as two user macros. When the motor is changed, only the corresponding User macro needs to be loaded, and the drive is ready to operate.

Actual signals and parameters

Chapter overview

The chapter describes the actual signals and parameters and gives the fieldbus equivalent values for each signal/parameter. More data is given in chapter [Additional data: actual signals and parameters](#).

Terms and abbreviations

Term	Definition
Absolute Maximum Frequency	Value of 20.02, or 20.01 if the absolute value of the minimum limit is greater than the maximum limit.
Actual signal	Signal measured or calculated by the drive. Can be monitored by the user. No user setting possible.
FbEq	Fieldbus equivalent: The scaling between the value shown on the panel and the integer used in serial communication.
Parameter	A user-adjustable operation instruction of the drive.



No.	Name/Value	Description	FbEq
01	ACTUAL SIGNALS	Basic signals for monitoring of the drive.	
01.02	MOTOR SPEED FILT	Calculated motor speed in rpm.	-20000 = -100% 20000 = 100% of motor abs. max. speed
01.03	FREQUENCY * * * * *	Calculated drive output frequency.	-100 = -1 Hz 100 = 1 Hz
01.04	MOTOR CURRENT	Measured motor current.	10 = 1 A
01.05	MOTOR TORQ FILT2	Calculated motor torque.	-10000 = -100% 10000 = 100% of motor nom. torque
01.06	POWER	Motor power.	-1000 = -100% 1000 = 100% of motor nom. power
01.07	DC VOLTAGE	Measured intermediate circuit voltage.	1 = 1 V
01.08	MAINS VOLTAGE	Calculated supply voltage.	1 = 1 V
01.09	MOTOR VOLTAGE	Calculated motor voltage.	1 = 1 V
01.10	PP TEMPERATURE	Temperature of the heatsink.	1 = 1 °C
01.11	EXTERNAL REF 1	External reference REF1 in Hz.	1 = 1 Hz
01.12	EXTERNAL REF 2 ***	External reference REF2. 100% corresponds to maximum process reference (PFC TRAD macro) or maximum frequency (Hand/Auto macro).	0 = 0% 10000 = 100% *****
01.13	CTRL LOCATION	Active control location. (1,2) LOCAL; (3) EXT1; (4) EXT2. See the chapter Program features .	See Descr.
01.14	TIME OF USAGE	Elapsed time counter. Runs when the control board is powered.	1 = 1 h
01.15	KILOWATT HOURS	kWh counter.	1 = 100 kWh
01.16	APPL BLOCK OUTPUT	Application block output signal. E.g. PFC application output.	0 = 0% 10000 = 100%
01.17	DI6-1 STATUS **	Status of digital inputs DI6-DI1 and the optional PFC extension module digital input 1 (DI7). <i>Example:</i> 0000001 = DI1 is on, DI2 to DI7 are off.	
01.18	AI1 [V]	Value of analogue input AI1.	1 = 0.001 V
01.19	AI2 [mA]	Value of analogue input AI2.	1 = 0.001 mA
01.20	AI3 [mA]	Value of analogue input AI3.	1 = 0.001 mA
01.21	RO3-1 STATUS	Status of relay outputs RO3-RO1. <i>Example:</i> 0000110 = RO1 is de-energised, RO2 and RO3 are energised.	
01.22	AO1 [mA]	Value of analogue output AO1.	1 = 0.001 mA
01.23	AO2 [mA]	Value of analogue output AO2.	1 = 0.001 mA
01.24	ACTUAL VALUE 1 * * * ***	Value of process feedback signal no. 1 received by the process PI controller. See par. 40.12.	0 = 0% 10000 = 100%
01.25	ACTUAL VALUE 2	Value of process feedback signal no. 2 received by the process PI controller. See par. 40.14.	0 = 0% 10000 = 100%

No.	Name/Value	Description	FbEq
01.26	CONTROL DEVIATION	Deviation of the PI controller, i.e. the difference between the process reference value and the process actual value.	-10000 = -100% 10000 = 100%
01.27	ACTUAL FUNC OUT	Result of the arithmetic operation selected with par. 40.04.	100 = 1
01.28	EXT AO1 [mA]	Value of output 1 of the analogue I/O extension module (optional).	1 = 0.001 mA
01.29	EXT AO2 [mA]	Value of output 2 of the analogue I/O extension module (optional).	1 = 0.001 mA
01.30	PP 1 TEMP	IGBT maximum temperature in inverter no. 1.	1 = 1 °C
01.31	PP 2 TEMP	IGBT maximum temperature in inverter no. 2 (used only in high power units with parallel inverters).	1 = 1 °C
01.32	PP 3 TEMP	IGBT maximum temperature in inverter no. 3 (used only in high power units with parallel inverters).	1 = 1 °C
01.33	PP 4 TEMP	IGBT maximum temperature in inverter no. 4 (used only in high power units with parallel inverters).	1 = 1 °C
01.37	MOTOR TEMP EST	Estimated motor temperature.	1 = 1 °C
01.38	AI5 [mA]	Value of analogue input AI5 read from AI1 of the analogue I/O extension module (optional). A voltage signal is also displayed in mA (instead of V).	1 = 0.001 mA
01.39	AI6 [mA]	Value of analogue input AI6 read from AI2 of the analogue I/O extension module (optional). A voltage signal is also displayed in mA (instead of V).	1 = 0.001 mA
01.40	DI7-12 STATUS	Status of digital inputs DI7 to DI12 read from the digital I/O extension modules (optional). E.g. value 000001: DI7 is on, DI8 to DI12 are off.	1 = 1
01.41	EXT RO STATUS	Status of the relay outputs on the digital I/O extension modules (optional). E.g. value 0000001: RO1 of module 1 is energised. Other relay outputs are de-energised.	1 = 1
01.42	PFC OPERATION TIM	Time since the latest Autochange. See parameter group 42.	1 = 1 h
01.43	MOTOR RUN-TIME	Motor run time counter. The counter runs when the inverter modulates.	1 = 10 h
01.44	FAN ON-TIME	Running time of the drive cooling fan. Note: The counter can be reset by the DriveWindow® PC tool. Resetting is recommended when the fan is replaced.	1 = 10 h
01.45	CTRL BOARD TEMP	Control board temperature.	1 = 1 °C
01.47	M/F STATE * ****	State of drive (either Follower or Master). (0,1) FOLLOWER; (2) MASTER.	See Descr.
01.48	START COUNTER	Number of drive starts. Can be reset using parameter 32.15.	1 = 1
01.50	SAVED KWH	Energy saved in kWh compared to direct-on-line motor connection. See parameter group 49 ENERGY OPT on page <CROSSREF>148.	1 = 100 kWh
01.51	SAVED GWH	Energy saved in GWh compared to direct-on-line motor connection.	1 = 1 GWh
01.52	SAVED AMOUNT	Monetary savings compared to direct-on-line motor connection. This value is a multiplication of parameters 01.50 SAVED KWH and 49.01 ENERGY TARIFF1. See parameter group 49 ENERGY OPT on page <CROSSREF>148.	1 = 100 cur
01.53	SAVED AMOUNT M	Monetary savings in millions compared to direct-on-line motor connection.	1 = 1 Mcur
01.54	SAVED CO2	Reduction in CO ₂ emissions in kilograms compared to direct-on-line motor connection. This value is calculated by multiplying saved energy in megawatt-hours by 500 kg/MWh. See parameter group 49 ENERGY OPT on page <CROSSREF>148.	1 = 100 kg

No.	Name/Value	Description	FbEq
01.55	SAVED CO2 KTON	Reduction in CO ₂ emissions in kilotons compared to direct-on-line motor connection.	1 = 1 kton
02 ACTUAL SIGNALS		Speed and torque reference monitoring signals.	
02.01	SPEED REF 2	Limited speed reference.	0 = 0% 20000 = 100% of motor abs. max. freq.
02.02	SPEED REF 3	Ramped and shaped speed reference.	20000 = 100% of motor abs. max. freq.
02.09	TORQUE REF 2	Speed controller output.	0 = 0% 10000 = 100% of motor nominal torque
02.10	TORQUE REF 3	Torque reference.	10000 = 100% of motor nominal torque
02.13	TORQ USED REF	Torque reference after frequency, voltage and torque limiters. 100% corresponds to the motor nominal torque.	10000 = 100%
02.17	SPEED ESTIMATED	Estimated motor speed. 100% corresponds to the Absolute Maximum Frequency of the motor.	20000 = 100%
02.19	MOTOR ACCELERATIO	Calculated motor acceleration from signal 01.02 MOTOR SPEED FILT.	1 = 1 rpm/s
03 INTERNAL DATA		Data words for monitoring of fieldbus communication (each signal is a 16-bit data word).	
03.01	MAIN CONTROL WORD	A 16-bit data word. See the chapter Fieldbus control .	
03.02	MAIN STATUS WORD	A 16-bit data word. See the chapter Fieldbus control .	
03.03	AUX STATUS WORD	A 16-bit data word. See the chapter Fieldbus control .	
03.04	LIMIT WORD 1	A 16-bit data word. See the chapter Fieldbus control .	
03.05	FAULT WORD 1	A 16-bit data word. See the chapter Fieldbus control .	
03.06	FAULT WORD 2	A 16-bit data word. See the chapter Fieldbus control .	
03.07	SYSTEM FAULT WORD	A 16-bit data word. See the chapter Fieldbus control .	
03.08	ALARM WORD 1	A 16-bit data word. See the chapter Fieldbus control .	
03.09	ALARM WORD 2	A 16-bit data word. See the chapter Fieldbus control .	
03.10	ALARM WORD 3	A 16-bit data word. See the chapter Fieldbus control .	
03.19	INT INIT FAULT	Fieldbus code of the latest fault. See chapter Fault tracing for the codes.	
03.20	FAULT CODE 1 LAST	Fieldbus code of the latest fault. See chapter Fault tracing for the codes.	
03.21	FAULT CODE 2 LAST	Fieldbus code of the 2nd latest fault.	
03.22	FAULT CODE 3 LAST	Fieldbus code of the 3rd latest fault.	
03.23	FAULT CODE 4 LAST	Fieldbus code of the 4th latest fault.	
03.24	FAULT CODE 5 LAST	Fieldbus code of the 5th latest fault.	
03.25	WARN CODE 1 LAST	Fieldbus code of the latest warning.	
03.26	WARN CODE 2 LAST	Fieldbus code of the 2nd latest warning.	

No.	Name/Value	Description	FbEq
03.27	WARN CODE 3 LAST	Fieldbus code of the 3rd latest warning.	
03.28	WARN CODE 4 LAST	Fieldbus code of the 4th latest warning.	
03.29	WARN CODE 5 LAST	Fieldbus code of the 5th latest warning.	
03.30	LIMIT WORD INV	A 16-bit data word. See the chapter <i>Fieldbus control</i> .	
05 PFC WORDS		Information on the PFC functionality.	
05.01	PFC STATUS	A 16-bit data word. See the chapter <i>Fieldbus control</i> .	
05.02	PFC ALARM WORD	A 16-bit data word. See the chapter <i>Fieldbus control</i> .	
05.03	PFC FAULT WORD	A 16-bit data word. See the chapter <i>Fieldbus control</i> .	
05.04	PFC ACT REF	Final reference after reference steps, Sleep boost, and forced reference (parameter group 44) functions.	
05.05	APPLIC REF AS Hz	Process PI controller output in Hz.	
05.06	AUX ON	Number of auxiliary/follower motors running.	1 = 1
05.07	WAKE UP ACT	Wake-up level (from Sleep mode).	
05.08	BOOST ACT	Actual boosted reference.	1 = 0.01%
05.11	ACT FLOW	Actual flow in m ³ /h as calculated by the drive. See parameter group 45 FLOWCONTROL .	1 = 1
05.12	SUM FLOW	Total calculated flow in m ³ ; stored when drive is powered off. Can be reset using parameter 45.02. See parameter group 45 FLOWCONTROL .	1 = 1
05.13	PRESSURE DEV	Difference between inlet and outlet pressures. See parameter group 45 FLOWCONTROL .	
05.15	SHARE AI1	Shared analogue input AI1 value received through the fibre optic link. See parameter group 65 SHARE IO .	1 = 0.001 V
05.16	SHARE AI2	Shared analogue input AI1 value received through the fibre optic link. See parameter group 65 SHARE IO .	1 = 0.001 mA
05.17	SHARE AI3	Shared analogue input AI1 value received through the fibre optic link. See parameter group 65 SHARE IO .	1 = 0.001 mA
05.21	LC STATUS	Level control status as a 16-bit data word. See the chapter <i>Fieldbus control</i> .	
05.23	ACT LEVEL ****	Measured fluid level for Level control in percent. The range 0...100% corresponds to the range of the analogue input selected for the level sensor (e.g. 4...20 mA). See parameter groups 13 ANALOGUE INPUTS and 47 LEVEL CONTROL .	1 = 1%
09 ACTUAL SIGNALS		Signals for the Adaptive Program.	
09.01	AI1 SCALED	Value of analogue input AI1 scaled to an integer value.	20000 = 10 V
09.02	AI2 SCALED	Value of analogue input AI2 scaled to an integer value.	20000 = 20 mA
09.03	AI3 SCALED	Value of analogue input AI3 scaled to an integer value.	20000 = 20 mA
09.04	AI5 SCALED	Value of analogue input AI5 scaled to an integer value.	20000 = 20 mA
09.05	AI6 SCALED	Value of analogue input AI6 scaled to an integer value.	20000 = 20 mA
09.06	DS MCW	Control Word (CW) of the Main Reference Data Set received from the master station through the fieldbus interface.	0 ... 65535 (Decimal)

No.	Name/Value	Description	FbEq
09.07	MASTER REF1	Reference 1 (REF1) of the Main Reference Data Set received from the master station through the fieldbus interface	-32768 ... 32767
09.08	MASTER REF2	Reference 2 (REF2) of the Main Reference Data Set received from the master station through the fieldbus interface	-32768 ... 32767
09.09	AUX DS VAL1	Reference 3 (REF3) of the Auxiliary Reference Data Set received from the master station through the fieldbus interface	-32768 ... 32767
09.10	AUX DS VAL2	Reference 4 (REF4) of the Auxiliary Reference Data Set received from the master station through the fieldbus interface	-32768 ... 32767
09.11	AUX DS VAL3	Reference 5 (REF5) of the Auxiliary Reference Data Set received from the master station through the fieldbus interface	-32768 ... 32767
09.12	LCU ACT SIGNAL 1	Line-side converter signal selected by parameter 95.08. A 16-bit data word.	
09.13	LCU ACT SIGNAL 2	Line-side converter signal selected by parameter 95.09. A 16-bit data word.	
<p>*Default signal for Multipump macro **Default signal for PFC TRAD macro ***Default signal for Hand/Auto macro ****Default signal for Level Control macro *****Of max. process reference (PFC TRAD macro) or max. frequency (Hand/Auto macro).</p>			

Index	Name/Selection	Description	FbEq
10 START/STOP/DIR			
10.01	EXT 1 STRT/STP/DI	Defines the connections and the source of the start, stop and direction commands for external control location 1 (EXT1). Notes: <ul style="list-style-type: none"> • The pulse (P) start/stop commands are not available if either the Multipump or Level Control macro is selected. • The pulse (P) start/stop commands are not available if motor interlocks (parameter 42.04) are ON. 	
	NOT SEL	No start, stop and direction command source.	1
	DI1	Start and stop through digital input DI1. 0 = stop; 1 = start. Direction is fixed according to parameter 10.03.  WARNING! After a fault reset, the drive will start if the start signal is on.	2
	DI1,2	Start and stop through digital input DI1. 0 = stop, 1 = start. Direction through digital input DI2. 0 = forward, 1 = reverse. To control direction, parameter 10.03 DIRECTION must be REQUEST.  WARNING! After a fault reset, the drive will start if the start signal is on.	3
	DI1P,2P	Pulse start through digital input DI1. 0 -> 1: Start. Pulse stop through digital input DI2. 1 -> 0: Stop. Direction of rotation is fixed according to parameter 10.03 DIRECTION.	4
	DI1P,2P,3	Pulse start through digital input DI1. 0 -> 1: Start. Pulse stop through digital input DI2. 1 -> 0: Stop. Direction through digital input DI3. 0 = forward, 1 = reverse. To control direction, parameter 10.03 DIRECTION must be REQUEST.	5
	DI1P,2P,3P	Pulse start forward through digital input DI1. 0 -> 1: Start forward. Pulse start reverse through digital input DI2. 0 -> 1: Start reverse. Pulse stop through digital input DI3. 1 -> "0": stop. To control the direction, parameter 10.03 DIRECTION must be REQUEST.	6
	DI6	See selection DI1.	7
	DI6,5	See selection DI1,2. DI6: Start/stop, DI5: direction.	8
	KEYPAD	Control panel. To control the direction, parameter 10.03 DIRECTION must be REQUEST.	9
	COMM.MODULE	Fieldbus Control Word.	10
	DI7	See selection DI1.	11
	DI7,8	See selection DI1,2.	12
	DI7P,8P	See selection DI1P,2P.	13
	DI7P,8P,9	See selection DI1P,2P,3.	14
	DI7P,8P,9P	See selection DI1P,2P,3P.	15
	EXT1STRT PTR	Source selected by parameter 10.04.	16
10.02	EXT 2 STRT/STP/DI	Defines the connections and the source of the start, stop and direction commands for external control location 2 (EXT2). Note: The pulse (P) start/stop commands are not available if motor interlocks (parameter 42.04) are ON. Note: A pulse (P) start/stop source when either the Multipump or Level macro is active is not allowed.	

Index	Name/Selection	Description	FbEq
	NOT SEL	See parameter 10.01 .	1
	DI1	See parameter 10.01 .	2
	DI1,2	See parameter 10.01 .	3
	DI1P,2P	See parameter 10.01 .	4
	DI1P,2P,3	See parameter 10.01 .	5
	DI1P,2P,3P	See parameter 10.01 .	6
	DI6	See parameter 10.01 .	7
	DI6,5	See parameter 10.01 .	8
	KEYPAD	See parameter 10.01 .	9
	COMM.MODULE	See parameter 10.01 .	10
	DI7	See parameter 10.01 .	11
	DI7,8	See parameter 10.01 .	12
	DI7P,8P	See parameter 10.01 .	13
	DI7P,8P,9	See parameter 10.01 .	14
	DI7P,8P,9P	See parameter 10.01 .	15
	EXT2STRT PTR	Source selected by parameter 10.05 .	16
10.03	DIRECTION	Enables the control of direction of rotation of the motor, or fixes the direction. Notes: <ul style="list-style-type: none"> • With the PFC TRAD macro, if external reference 2 (EXT2) is the active reference, this parameter is fixed to FORWARD. • The Anti-jam function can override this parameter. See parameter 46.01. 	
	FORWARD	Fixed to forward.	1
	REVERSE	Fixed to reverse.	2
	REQUEST	Direction of rotation control allowed.	3
10.04	EXT 1 STRT PTR	Defines the source or constant for value EXT1STRT PTR of parameter 10.01 .	
	-255.255.31 ... +255.255.31 / C.-32768 ... C.32767	Parameter index or a constant value: <ul style="list-style-type: none"> • Parameter pointer: Inversion, group, index and bit fields. The bit number is effective only for blocks handling boolean inputs. • Constant value: Inversion and constant fields. Inversion field must have value C to enable the constant setting. 	-
10.05	EXT 2 STRT PTR	Defines the source or constant for value EXT2STRT PTR of parameter 10.02 .	
	-255.255.31 ... +255.255.31 / C.-32768 ... C.32767	Parameter index or a constant value. See Parameter 10.04 for information on the difference.	-
11 REFERENCE SELECT		Panel reference type, external control location selection and external reference sources and limits	
11.02	EXT1/EXT2 SELECT	Defines the source from which the drive reads the signal that selects between the two external control locations, EXT1 or EXT2.	
	EXT1	EXT1 active. The control signal sources are defined by parameter 10.01 and 11.03 .	1
	EXT2	EXT2 active. The control signal sources are defined by parameter 10.02 and 11.06 .	2
	DI1	Digital input DI1. 0 = EXT1, 1 = EXT2.	3
	DI2	See selection DI1.	4
	DI3	See selection DI1.	5

Index	Name/Selection	Description	FbEq
	DI4	See selection DI1.	6
	DI5	See selection DI1.	7
	DI6	See selection DI1.	8
	DI7	See selection DI1.	9
	DI8	See selection DI1.	10
	DI9	See selection DI1.	11
	DI10	See selection DI1.	12
	DI11	See selection DI1.	13
	DI12	See selection DI1.	14
	COMM.MODULE	Fieldbus Control Word, bit 11.	15
	EXT1/2SELPTR	Source selected by parameter 11.09 .	16
11.03	EXT REF1 SELECT	Selects the signal source for external reference REF1	
	KEYPAD	Control panel. The first line on the display shows the reference value.	1
	AI1	Analogue input AI1.	2
	AI2	Analogue input AI2.	3
	AI3	Analogue input AI3.	4
	AI1+AI3	Summation of analogue inputs AI1 and AI3.	5
	AI2+AI3	Summation of analogue inputs AI2 and AI3.	6
	AI1-AI3	Subtraction of analogue inputs AI1 and AI3.	7
	AI2-AI3	Subtraction of analogue inputs AI2 and AI3.	8
	AI1*AI3	Multiplication of analogue inputs AI1 and AI3.	9
	AI2*AI3	Multiplication of analogue inputs AI2 and AI3.	10
	MIN(AI1,3)	Minimum of analogue inputs AI1 and AI3.	11
	MIN(AI2,3)	Minimum of analogue inputs AI2 and AI3.	12
	MAX(AI1,3)	Maximum of analogue inputs AI1 and AI3.	13
	MAX(AI2,3)	Maximum of analogue inputs AI2 and AI3.	14
	COMM.MODULE	Fieldbus reference REF1.	15
	EXT1REF PTR	Source selected by parameter 11.10 .	16
	AI5	Analogue input AI5.	17
	AI6	Analogue input AI6.	18
	AI5+AI6	Summation of analogue inputs AI5 and AI6.	19
	AI5-AI6	Subtraction of analogue inputs AI5 and AI6.	20
	AI5*AI6	Multiplication of analogue inputs AI5 and AI6.	21
	MIN(AI5,AI6)	Minimum of analogue inputs AI5 and AI6.	22
	MAX(AI5,AI6)	Maximum of analogue inputs AI5 and AI6.	23
11.04	EXT REF1 MINIMUM	Defines the minimum value for external reference REF1 (absolute value). Corresponds to the minimum setting of the source signal used.	

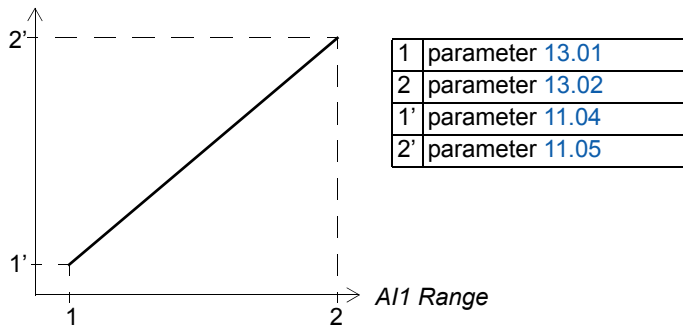
Index	Name/Selection	Description	FbEq
	0 ... 120 Hz	<p><i>Example:</i> Analogue input AI1 is selected as the reference source (value of parameter 11.03 is AI1). The reference minimum and maximum correspond to the AI minimum and maximum settings as follows:</p> <p><i>EXT REF1 Range</i></p>  <p>Note: If the reference is given through fieldbus, the scaling differs from that of an analogue signal. See the chapter <i>Fieldbus control</i> for more information.</p>	0 ... 120
11.05	EXT REF1 MAXIMUM	Defines the maximum value for external reference REF1 (absolute value). Corresponds to the maximum setting of the used source signal.	
	0 ... 120 Hz	See parameter 11.04.	0 ... 120
11.06	EXT REF2 SELECT	Selects the signal source for external reference REF2.	
	KEYPAD	See parameter 11.03.	1
	AI1	See parameter 11.03.	2
	AI2	See parameter 11.03.	3
	AI3	See parameter 11.03.	4
	AI1+AI3	See parameter 11.03.	5
	AI2+AI3	See parameter 11.03.	6
	AI1-AI3	See parameter 11.03.	7
	AI2-AI3	See parameter 11.03.	8
	AI1*AI3	See parameter 11.03.	9
	AI2*AI3	See parameter 11.03.	10
	MIN(AI1,3)	See parameter 11.03.	11
	MIN(AI2,3)	See parameter 11.03.	12
	MAX(AI1,3)	See parameter 11.03.	13
	MAX(AI2,3)	See parameter 11.03.	14
	COMM.MODULE	See parameter 11.03.	15
	EXT2REF PTR	Source selected by parameter 11.11.	16
	AI5	Analogue input AI5.	17
	AI6	Analogue input AI6.	18
	AI5+AI6	Summation of analogue inputs AI5 and AI6.	19
	AI5-AI6	Subtraction of analogue inputs AI5 and AI6.	20
	AI5*AI6	Multiplication of analogue inputs AI5 and AI6.	21
	MIN(AI5,AI6)	Minimum of analogue inputs AI5 and AI6.	22
	MAX(AI5,AI6)	Maximum of analogue inputs AI5 and AI6.	23

Index	Name/Selection	Description	FbEq															
11.07	EXT REF2 MINIMUM	Defines the minimum value for external reference REF2 (absolute value). Corresponds to the minimum setting of the source signal used.																
	0 ... 100%	With PFC TRAD macro, sets the minimum process reference in percent of the maximum process quantity. With Hand/Auto macro, sets the minimum frequency reference in percent of the Absolute Maximum Frequency. - Source is an analogue input: See example at parameter 11.04. - Source is a serial link: See the chapter <i>Fieldbus control</i> .	0 ... 10000															
11.08	EXT REF2 MAXIMUM	Defines the maximum value for external reference REF2 (absolute value). Corresponds to the maximum setting of the source signal used.																
	0 ... 500%	Setting range. Correspondence to the source signal limits: - Source is an analogue input: See parameter 11.04. - Source is a serial link: See the chapter <i>Fieldbus control</i> .	0 ... 50000															
11.09	EXT 1/2 SEL PTR	Defines the source or constant for value EXT 1/2 SEL PTR of parameter 11.02.																
	-255.255.31 ... +255.255.31 / C.-32768 ... C.32767	Parameter index or a constant value. See Parameter 10.04 for information on the difference.	-															
11.10	EXT 1 REF PTR	Defines the source or constant for value EXT1REF PTR of parameter 11.03.																
	-255.255.31 ... +255.255.31 / C.-32768 ... C.32767	Parameter index or a constant value. See Parameter 10.04 for information on the difference.	-															
11.11	EXT 2 REF PTR	Defines the source or constant for value EXT2REF PTR of parameter 11.06.																
	-255.255.31 ... +255.255.31 / C.-32768 ... C.32767	Parameter index or a constant value. See Parameter 10.04 for information on the difference.	-															
12 CONSTANT FREQ		Constant frequency selection and values. An active constant frequency overrides the drive frequency reference. Note: If the PFC TRAD macro is selected, parameter 12.01 is set to a value other than NOT SEL, and one of the selected digital inputs is ON, the PFC logic is bypassed, i.e. no process PI controller is in use and the direct-on-line motors are not started.																
12.01	CONST FREQ SEL	Activates the constant frequencies or selects the activation signal.																
	NOT SEL	No constant frequencies in use.	1															
	DI4 (FREQ1)	Frequency defined by parameter 12.02 is activated through digital input DI4. 1 = active, 0 = inactive.	2															
	DI5 (FREQ2)	Frequency defined by parameter 12.03 is activated through digital input DI5. 1 = active, 0 = inactive.	3															
	DI4,5	Constant frequency selection through digital input DI4 and DI5. <table border="1" data-bbox="539 1585 1305 1749"> <thead> <tr> <th>DI4</th> <th>DI5</th> <th>Constant speed in use</th> </tr> </thead> <tbody> <tr> <td>0</td> <td>0</td> <td>No constant frequency</td> </tr> <tr> <td>1</td> <td>0</td> <td>Frequency defined by parameter 12.02</td> </tr> <tr> <td>0</td> <td>1</td> <td>Frequency defined by parameter 12.03</td> </tr> <tr> <td>1</td> <td>1</td> <td>Frequency defined by parameter 12.04</td> </tr> </tbody> </table>	DI4	DI5	Constant speed in use	0	0	No constant frequency	1	0	Frequency defined by parameter 12.02	0	1	Frequency defined by parameter 12.03	1	1	Frequency defined by parameter 12.04	4
DI4	DI5	Constant speed in use																
0	0	No constant frequency																
1	0	Frequency defined by parameter 12.02																
0	1	Frequency defined by parameter 12.03																
1	1	Frequency defined by parameter 12.04																
	DI11 (FREQ1)	Frequency defined by parameter 12.02 is activated through digital input DI11. 1 = active, 0 = inactive.	5															
	DI12 (FREQ2)	Frequency defined by parameter 12.03 is activated through digital input DI12. 1 = active, 0 = inactive.	6															
	DI11,12	See selection DI4,5.	7															

Index	Name/Selection	Description	FbEq
	DI1 (FREQ1)	Frequency defined by parameter 12.02 is activated through digital input DI1. 1 = active, 0 = inactive.	8
12.02	CONST FREQ 1	Defines frequency 1. An absolute value; does not include direction information.	
	0 ... 120 Hz	Setting range	0 ... 120
12.03	CONST FREQ 2	Defines frequency 2. An absolute value; does not include direction information.	
	0 ... 120 Hz	Setting range	0 ... 120
12.04	CONST FREQ 3	Defines frequency 3. An absolute value; does not include direction information.	
	0 ... 120 Hz	Setting range	0 ... 120
13 ANALOGUE INPUTS		Analogue input signal processing.	
13.01	MINIMUM AI1	Defines the minimum value for analogue input AI1. When used as a reference, the value corresponds to the reference minimum setting. <i>Example:</i> If AI1 is selected as the source for external reference REF1, this value corresponds to the value of parameter 11.04.	
	0 V	Zero volts. Note: The program cannot detect a loss of analogue input signal.	1
	2 V	Two volts.	2
	TUNED VALUE	The value measured by the tuning function. See the selection TUNE.	3
	TUNE	Triggering of the value measurement. Procedure: - Connect the minimum signal to input. - Set the parameter to TUNE. Note: The readable range in tuning is 0 ... 10 V.	4
13.02	MAXIMUM AI1	Defines the maximum value for analogue input AI1. When used as a reference, the value corresponds to the reference maximum setting. <i>Example:</i> If AI1 is selected as the source for external reference REF1, this value corresponds to the value of parameter 11.05.	
	10 V	Ten volts (DC).	1
	TUNED VALUE	The value measured by the tuning function. See the selection TUNE.	2
	TUNE	Triggering of the value measurement. Procedure: - Connect the maximum signal to input. - Set the parameter to TUNE. Note: The readable range in tuning is 0 ... 10 V.	3

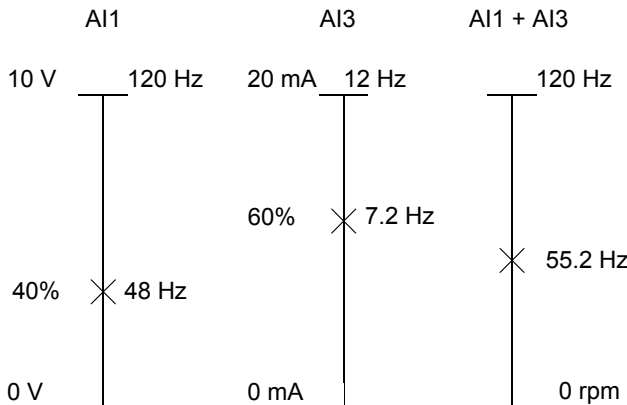
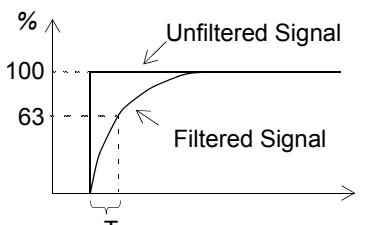
Index	Name/Selection	Description	FbEq
13.03	SCALE AI1	<p>Scales analogue input AI1.</p> <p><i>Example:</i> The effect on frequency reference REF1 when:</p> <ul style="list-style-type: none"> - REF1 source selection (Parameter 11.03) = AI1+AI3 - REF1 maximum value setting (Parameter 11.05) = 120 Hz - Actual AI1 value = 4 V (40% of the full scale value) - Actual AI3 value = 12 mA (60% of the full scale value) - AI1 scaling = 100%, AI3 scaling = 10%  <p style="text-align: center;"> A11 A13 A11 + A13 </p> <p style="text-align: center;"> 10 V 20 mA 120 Hz </p> <p style="text-align: center;"> 40% 60% 120 Hz </p> <p style="text-align: center;"> X 48 Hz X 7.2 Hz X 55.2 Hz </p> <p style="text-align: center;"> 0 V 0 mA 0 rpm </p>	
	0.0 ... 1000.0%	Scaling range	0 ... 10000
13.04	FILTER AI1	<p>Defines the filter time constant for analogue input AI1.</p>  <p style="text-align: right;"> $O = I \times (1 - e^{-t/T})$ I = filter input (step) O = filter output t = time T = filter time constant </p> <p>Note: The signal is also filtered due to the signal interface hardware (10 ms time constant). This cannot be changed by any parameter.</p>	
	0.00 ... 10.00 s	Filter time constant	0 ... 1000
13.05	INVERT AI1	Activates/deactivates the inversion of analogue input AI1.	
	NO	No inversion	0
	YES	Inversion active. The maximum value of the analogue input signal corresponds to the minimum reference and vice versa.	65535
13.06	MINIMUM AI2	See parameter 13.01.	
	0 mA	See parameter 13.01.	1
	4 mA	See parameter 13.01.	2
	TUNED VALUE	See parameter 13.01.	3
	TUNE	See parameter 13.01.	4
13.07	MAXIMUM AI2	See parameter 13.02.	
	20 mA	See parameter 13.02.	1
	TUNED VALUE	See parameter 13.02.	2
	TUNE	See parameter 13.02.	3

Index	Name/Selection	Description	FbEq
13.08	SCALE AI2	See parameter 13.03.	
	0.0 ... 1000.0%	See parameter 13.03.	0 ... 10000
13.09	FILTER AI2	See parameter 13.04.	
	0.00 ... 10.00 s	See parameter 13.04.	0 ... 1000
13.10	INVERT AI2	See parameter 13.05.	
	NO	See parameter 13.05.	0
	YES	See parameter 13.05.	65535
13.11	MINIMUM AI3	See parameter 13.01.	
	0 mA	See parameter 13.01.	1
	4 mA	See parameter 13.01.	2
	TUNED VALUE	See parameter 13.01.	3
	TUNE	See parameter 13.01.	4
13.12	MAXIMUM AI3	See parameter 13.02.	
	20 mA	See parameter 13.02.	1
	TUNED VALUE	See parameter 13.02.	2
	TUNE	See parameter 13.02.	3
13.13	SCALE AI3	See parameter 13.03.	
	0.0 ... 1000.0%	See parameter 13.03.	0 ... 10000
13.14	FILTER AI3	See parameter 13.04.	
	0.00 ... 10.00 s	See parameter 13.04.	0 ... 1000
13.15	INVERT AI3	See parameter 13.05.	
	NO	See parameter 13.05.	0
	YES	See parameter 13.05.	65535
13.16	MINIMUM AI5	See parameter 13.01.	
	0 mA	See parameter 13.01.	1
	4 mA	See parameter 13.01.	2
	TUNED VALUE	See parameter 13.01.	3
	TUNE	See parameter 13.01.	4
13.17	MAXIMUM AI5	See parameter 13.02.	
	20 mA	See parameter 13.02.	1
	TUNED VALUE	See parameter 13.02.	2
	TUNE	See parameter 13.02.	3
13.18	SCALE AI5	See parameter 13.03.	
	0.0 ... 1000.0%	See parameter 13.03.	0 ... 10000
13.19	FILTER AI5	See parameter 13.04.	
	0.00 ... 10.00 s	See parameter 13.04.	0 ... 1000
13.20	INVERT AI5	See parameter 13.05.	
	NO	See parameter 13.05.	0
	YES	See parameter 13.05.	65535
13.21	MINIMUM AI6	See parameter 13.01.	
	0 mA	See parameter 13.01.	1
	4 mA	See parameter 13.01.	2

Index	Name/Selection	Description	FbEq
	TUNED VALUE	See parameter 13.01 .	3
	TUNE	See parameter 13.01 .	4
13.22	MAXIMUM AI6	See parameter 13.02 .	
	20 mA	See parameter 13.02 .	1
	TUNED VALUE	See parameter 13.02 .	2
	TUNE	See parameter 13.02 .	3
13.23	SCALE AI6	See parameter 13.03 .	
	0.0 ... 1000.0%	See parameter 13.03 .	0 ... 10000
13.24	FILTER AI6	See parameter 13.04 .	
	0.00 ... 10.00 s	See parameter 13.04 .	0 ... 1000
13.25	INVERT AI6	See parameter 13.05 .	
	NO	See parameter 13.05 .	0
	YES	See parameter 13.05 .	65535
14 RELAY OUTPUTS		Status information indicated through the relay outputs, and the relay operating delays	
14.01	RELAY RO1 OUTPUT	Selects a drive status indicated through relay output RO1. The relay energises when the status meets the setting.	
	M1 START	Start/stop control for motor 1 (Interlocks enabled) or auxiliary motor 1 (Interlocks OFF). Should be selected only with the PFC TRAD macro active. See also parameter 42.04 . Note: The parameter (or parameter 14.04) must be set to this value if any of the following conditions is valid: - (External control) External reference 2 is active and par. 42.06 is greater than zero. - Par. 42.01 is 1 or greater.	1
	NOT USED	Not used.	2
	READY	Ready to function: Run Enable signal on, no fault.	3
	RUNNING	Running: Start signal on, Run Enable signal on, no active fault.	4
	FAULT	Fault	5
	FAULT(-1)	Inverted fault. Relay is de-energised on a fault trip.	6
	FAULT(RST)	Fault. Automatic reset after the autoreset delay. See parameter group 31 AUTOMATIC RESET .	7
	STALL WARN	Warning by the stall protection function. See parameter 30.10 .	8
	STALL FLT	Fault trip by the stall protection function. See parameter 30.10 .	9
	MOT TMP WRN	Warning trip of the motor temperature supervision function. See parameter 30.04 .	10
	MOT TMP FLT	Fault trip of the motor temperature supervision function. See parameter 30.04 .	11
	ACS TMP WRN	Warning by the drive temperature supervision function: 115 °C (239 °F).	12
	ACS TMP FLT	Fault trip by the drive temperature supervision function: 125 °C (257 °F).	13
	FAULT/WARN	Fault or warning active	14
	WARNING	Warning active	15
	REVERSED	Motor rotates in reverse direction.	16
	EXT CTRL	Drive is under external control.	17

Index	Name/Selection	Description	FbEq
	REF 2 SEL	External reference REF 2 is in use.	18
	DC OVERVOLT	The intermediate circuit DC voltage has exceeded the overvoltage limit.	19
	DC UNDERVOL	The intermediate circuit DC voltage has fallen below the undervoltage limit.	20
	FREQ 1 LIM	Motor frequency at supervision limit 1. See parameters 32.01 and 32.02 .	21
	FREQ 2 LIM	Motor speed at supervision limit 2. See parameters 32.03 and 32.04 .	22
	CURRENT LIM	Motor current at the supervision limit. See parameters 32.05 and 32.06 .	23
	REF 1 LIM	External reference REF1 at the supervision limit. See parameters 32.07 and 32.08 .	24
	REF 2 LIM	External reference REF2 at the supervision limit. See parameters 32.09 and 32.10 .	25
	STARTED	The drive has received a start command.	26
	LOSS OF REF	The drive has no reference.	27
	AT SPEED	The actual value has reached the reference value. In speed control, the speed error is less or equal to 10% of the nominal motor speed.	28
	ACT 1 LIM	Actual value ACT1 at a supervision limit. See parameters 32.11 and 32.12 .	29
	ACT 2 LIM	Actual value ACT2 at a supervision limit. See parameters 32.13 and 32.14 .	30
	COMM. MODULE	The relay is controlled by fieldbus reference REF3. See the chapter <i>Fieldbus control</i> .	31
	INLET LOW	Pressure at the pump/fan inlet has fallen below the set supervision limit (and remained so longer than the set delay time). Refer to parameter group 44.	32
	OUTLET HIGH	Pressure at the pump/fan outlet has exceeded the set supervision limit (and remained so longer than the set delay time). Refer to parameter group 44.	33
	PROFILE HIGH	Actual signal 01.16 APPL BLOCK OUTPUT or 01.26 CONTROL DEVIATION has remained above the set supervision limit longer than the set delay time. See parameter group 44.	34
	RO PTR1	Source selected by parameter 14.08 .	35
14.02	RELAY RO2 OUTPUT	Selects the drive status to be indicated through relay output RO2. The relay energises when the status meets the setting.	
	M2 START	Start/stop control for motor 2 (Interlocks enabled) or auxiliary motor 2 (Interlocks OFF). Should be selected only with the PFC TRAD macro active. See also parameter 42.04 . Note: The parameter (or parameter 14.05) must be set to this value if any of the following conditions apply: - (External control) External reference 2 is active, par. 42.06 is greater than zero, and par. 42.01 is 1 or greater. - Par. 42.01 is 1 or greater.	1
	NOT USED	See parameter 14.01 .	2
	READY	See parameter 14.01 .	3
	RUNNING	See parameter 14.01 .	4
	FAULT	See parameter 14.01 .	5
	FAULT(-1)	See parameter 14.01 .	6
	FAULT(RST)	See parameter 14.01 .	7
	STALL WARN	See parameter 14.01 .	8
	STALL FLT	See parameter 14.01 .	9
	MOT TMP WRN	See parameter 14.01 .	10
	MOT TMP FLT	See parameter 14.01 .	11

Index	Name/Selection	Description	FbEq
	ACS TMP WRN	See parameter 14.01.	12
	ACS TMP FLT	See parameter 14.01.	13
	FAULT/WARN	See parameter 14.01.	14
	WARNING	See parameter 14.01.	15
	REVERSED	See parameter 14.01.	16
	EXT CTRL	See parameter 14.01.	17
	REF 2 SEL	See parameter 14.01.	18
	DC OVERVOLT	See parameter 14.01.	19
	DC UNDERVOL	See parameter 14.01.	20
	FREQ 1 LIM	See parameter 14.01.	21
	FREQ 2 LIM	See parameter 14.01.	22
	CURRENT LIM	See parameter 14.01.	23
	REF 1 LIM	See parameter 14.01.	24
	REF 2 LIM	See parameter 14.01.	25
	STARTED	See parameter 14.01.	26
	LOSS OF REF	See parameter 14.01.	27
	AT SPEED	See parameter 14.01.	28
	ACT 1 LIM	See parameter 14.01.	29
	ACT 2 LIM	See parameter 14.01.	30
	COMM. MODULE	See parameter 14.01.	31
	INLET LOW	See parameter 14.01.	32
	OUTLET HIGH	See parameter 14.01.	33
	PROFILE HIGH	See parameter 14.01.	34
	RO PTR2	Source selected by parameter 14.09.	35
14.03	RELAY RO3 OUTPUT	Selects the drive status to be indicated through relay output RO3. The relay energises when the status meets the setting.	
	M3 START	Start/stop control for motor 3 (Interlocks enabled) or auxiliary motor 3 (Interlocks OFF). Should be selected only with the PFC TRAD macro active. See also parameter 42.04. Note: The parameter (or parameter 14.06) must be set to this value if any of the following conditions apply: - (External control) External reference 2 is active, par. 42.06 is greater than zero, and par. 42.01 is 2 or greater. - Par. 42.01 is 2 or greater.	1
	NOT USED	See parameter 14.01.	2
	READY	See parameter 14.01.	3
	RUNNING	See parameter 14.01.	4
	FAULT	See parameter 14.01.	5
	FAULT(-1)	See parameter 14.01.	6
	FAULT(RST)	See parameter 14.01.	7
	STALL WARN	See parameter 14.01.	8
	STALL FLT	See parameter 14.01.	9
	MOT TMP WRN	See parameter 14.01.	10
	MOT TMP FLT	See parameter 14.01.	11

Index	Name/Selection	Description	FbEq
	ACS TMP WRN	See parameter 14.01.	12
	ACS TMP FLT	See parameter 14.01.	13
	FAULT/WARN	See parameter 14.01.	14
	WARNING	See parameter 14.01.	15
	REVERSED	See parameter 14.01.	16
	EXT CTRL	See parameter 14.01.	17
	REF 2 SEL	See parameter 14.01.	18
	DC OVERVOLT	See parameter 14.01.	19
	DC UNDERVOL	See parameter 14.01.	20
	FREQ 1 LIM	See parameter 14.01.	21
	FREQ 2 LIM	See parameter 14.01.	22
	CURRENT LIM	See parameter 14.01.	23
	REF 1 LIM	See parameter 14.01.	24
	REF 2 LIM	See parameter 14.01.	25
	STARTED	See parameter 14.01.	26
	LOSS OF REF	See parameter 14.01.	27
	AT SPEED	See parameter 14.01.	28
	MAGN READY	The motor is magnetised and ready to give nominal torque (nominal magnetising of the motor has been reached).	29
	USER 2 SEL	User Macro 2 is in use.	30
	COMM. MODULE	See parameter 14.01.	31
	INLET LOW	See parameter 14.01.	32
	OUTLET HIGH	See parameter 14.01.	33
	PROFILE HIGH	See parameter 14.01.	34
	RO PTR3	Source selected by parameter 14.10.	35
14.04	RDIO MOD1 RO1	Selects the drive status indicated through relay output RO1 of digital I/O extension module 1 (optional, see parameter 98.03).	
	M4 START	Start/stop control for motor 4 (Interlocks enabled) or auxiliary motor 4 (Interlocks OFF). Should be selected only with the PFC TRAD macro active. See also parameter 42.04. Note: The parameter (or parameter 14.07) must be set to this value if any of the following conditions apply: - (External control) External reference 2 is active, par. 42.06 is greater than zero, and par. 42.01 is 3 or greater. - Par. 42.01 is 3 or greater.	1
	READY	See parameter 14.01.	2
	RUNNING	See parameter 14.01.	3
	FAULT	See parameter 14.01.	4
	FAULT(-1)	See parameter 14.01.	5
	FREQ 1 LIM	See parameter 14.01.	6
	ACT 1 LIM	See parameter 14.01.	7
	INLET LOW	See parameter 14.01.	8
	OUTLET HIGH	See parameter 14.01.	9
	PROFILE HIGH	See parameter 14.01.	10

Index	Name/Selection	Description	FbEq
	M1 START	See parameter 14.01.	11
	RO PTR4	Source selected by parameter 14.11.	12
14.05	RDIO MOD1 RO2	Selects the drive status indicated through relay output RO2 of digital I/O extension module 1 (optional, see parameter 98.03).	
	M5 START	Start/stop control for motor 5 when the Interlocks function is in use. Should be selected only with the PFC TRAD macro active. See also parameter 42.04. Note: The parameter must be set to this value if any of the following conditions apply: - (External control) External reference 2 is active, par. 42.06 is greater than zero, and par. 42.01 is 4. - Par. 42.01 is 4.	1
	READY	See parameter 14.01.	2
	RUNNING	See parameter 14.01.	3
	FAULT	See parameter 14.01.	4
	FAULT(-1)	See parameter 14.01.	5
	FREQ 2 LIM	See parameter 14.01.	6
	ACT 2 LIM	See parameter 14.01.	7
	INLET LOW	See parameter 14.01.	8
	OUTLET HIGH	See parameter 14.01.	9
	PROFILE HIGH	See parameter 14.01.	10
	M2 START	See parameter 14.02.	11
	RO PTR5	Source selected by parameter 14.12.	12
14.06	RDIO MOD2 RO1	Selects the drive status indicated through relay output RO1 of digital I/O extension module 2 (optional, see parameter 98.03).	
	READY	See parameter 14.01.	1
	RUNNING	See parameter 14.01.	2
	FAULT	See parameter 14.01.	3
	FAULT(-1)	See parameter 14.01.	4
	FREQ 1 LIM	See parameter 14.01.	5
	ACT 1 LIM	See parameter 14.01.	6
	INLET LOW	See parameter 14.01.	7
	OUTLET HIGH	See parameter 14.01.	8
	PROFILE HIGH	See parameter 14.01.	9
	M3 START	See parameter 14.03.	10
	RO PTR6	Source selected by parameter 14.13.	11
14.07	RDIO MOD2 RO2	Selects the drive status indicated through relay output RO2 of digital I/O extension module 2 (optional, see parameter 98.03).	
	READY	See parameter 14.01.	1
	RUNNING	See parameter 14.01.	2
	FAULT	See parameter 14.01.	3
	FAULT(-1)	See parameter 14.01.	4
	FREQ 2 LIM	See parameter 14.01.	5
	ACT 2 LIM	See parameter 14.01.	6
	INLET LOW	See parameter 14.01.	7

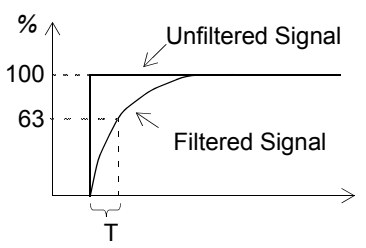

Index	Name/Selection	Description	FbEq
	OUTLET HIGH	See parameter 14.01 .	8
	PROFILE HIGH	See parameter 14.01 .	9
	M4 START	See parameter 14.04 .	10
	RO PTR7	Source selected by parameter 14.14 .	11
14.08	RO PTR1	Defines the source or constant for value RO PTR1 of parameter 14.01 .	
	-255.255.31 ... +255.255.31 / C.-32768 ... C.32767	Parameter index or a constant value. See Parameter 10.04 for information on the difference.	-
14.09	RO PTR2	Defines the source or constant for value RO PTR2 of parameter 14.02 .	
	-255.255.31 ... +255.255.31 / C.-32768 ... C.32767	Parameter index or a constant value. See Parameter 10.04 for information on the difference.	-
14.10	RO PTR3	Defines the source or constant for value RO PTR3 of parameter 14.03 .	
	-255.255.31 ... +255.255.31 / C.-32768 ... C.32767	Parameter index or a constant value. See Parameter 10.04 for information on the difference.	-
14.11	RO PTR4	Defines the source or constant for value RO PTR4 of parameter 14.04 .	
	-255.255.31 ... +255.255.31 / C.-32768 ... C.32767	Parameter index or a constant value. See Parameter 10.04 for information on the difference.	-
14.12	RO PTR5	Defines the source or constant for value RO PTR5 of parameter 14.05 .	
	-255.255.31 ... +255.255.31 / C.-32768 ... C.32767	Parameter index or a constant value. See Parameter 10.04 for information on the difference.	-
14.13	RO PTR6	Defines the source or constant for value RO PTR6 of parameter 14.06 .	
	-255.255.31 ... +255.255.31 / C.-32768 ... C.32767	Parameter index or a constant value. See Parameter 10.04 for information on the difference.	-
14.14	RO PTR7	Defines the source or constant for value RO PTR7 of parameter 14.07 .	
	-255.255.31 ... +255.255.31 / C.-32768 ... C.32767	Parameter index or a constant value. See Parameter 10.04 for information on the difference.	-
15 ANALOGUE OUTPUTS		Selection of the actual signals to be indicated through the analogue outputs. Output signal processing. See also parameter group 96 ANALOGUE OUTPUTS .	
15.01	ANALOGUE OUTPUT1	Connects a drive signal to analogue output AO1.	
	NOT USED	Not in use	1
	SPEED	Motor speed. 20 mA = motor nominal speed. The updating interval is 24 ms.	2
	FREQUENCY	Output frequency. 20 mA = motor nominal frequency. The updating interval is 24 ms.	3
	CURRENT	Output current. 20 mA = motor nominal current. The updating interval is 24 ms.	4
	TORQUE	Motor torque. 20 mA = 100% of motor nominal rating. The updating interval is 24 ms.	5
	POWER	Motor power. 20 mA = 100% of motor nominal rating. The updating interval is 100 ms.	6

Index	Name/Selection	Description	FbEq
	DC BUS VOLT	DC bus voltage. 20 mA = 100% of the reference value. The reference value is 540 VDC. ($= 1.35 \times 400 \text{ V}$) for 380 ... 415 VAC supply voltage rating and 675 VDC ($= 1.35 \times 500 \text{ V}$) for 380 ... 500 VAC supply. The updating interval is 24 ms.	7
	OUTPUT VOLT	Motor voltage. 20 mA = motor rated voltage. The updating interval is 100 ms.	8
	REFERENCE	Active reference that the drive is currently following. 20 mA = 100 % of the active reference. The updating interval is 24 ms.	9
	CONTROL DEV	The difference between the reference and the actual value of the process PI controller. 0/4 mA = -100%, 10/12 mA = 0%, 20 mA = 100%. The updating interval is 24 ms.	10
	ACTUAL 1	Value of variable ACT1 used in the process PI control. 20 mA = value of parameter 40.06. The updating interval is 24 ms.	11
	ACTUAL 2	Value of variable ACT2 used in the process PI control. 20 mA = value of parameter 40.10. The updating interval is 24 ms.	12
	PICON OUTP	The reference as taken from the output of the PI controller. The updating interval is 24 ms.	13
	PICON REF	The reference as taken from the input of the PI controller. The updating interval is 24 ms.	14
	ACTUAL FUNC	Result of the arithmetic operation selected by parameter 40.04 scaled by parameter 40.15.	15
	COMM MODULE	The value is read from fieldbus reference REF4. See <i>Fieldbus control</i> .	16
	AO1 PTR	Source selected by parameter 15.11.	17
15.02	INVERT AO1	Inverts the analogue output AO1 signal. The analogue signal is at the minimum level when the indicated drive signal is at its maximum level and vice versa.	
	NO	Inversion off	0
	YES	Inversion on	65535
15.03	MINIMUM AO1	Defines the minimum value of the analogue output signal AO1.	
	0 mA	Zero mA	1
	4 mA	Four mA	2
15.04	FILTER AO1	Defines the filtering time constant for analogue output AO1.	
	0.00 ... 10.00 s	Filter time constant  $O = I \cdot (1 - e^{-t/T})$ <p>I = filter input (step) O = filter output t = time T = filter time constant</p> <p>Note: Even if you select 0 s as the minimum value, the signal is still filtered with a time constant of 10 ms due to the signal interface hardware. This cannot be changed by any parameters.</p>	0 ... 1000
15.05	SCALE AO1	Scales the analogue output AO1 signal.	



Index	Name/Selection	Description	FbEq
	10 ... 1000%	<p>Scaling factor. If the value is 100%, the reference value of the drive signal corresponds to 20 mA.</p> <p><i>Example:</i> The nominal motor current is 7.5 A and the measured maximum current at maximum load 5 A. The motor current 0 to 5 A needs to be read as 0 to 20 mA analogue signal through AO1. The required settings are:</p> <ol style="list-style-type: none"> 1. AO1 is set to CURRENT by parameter 15.01. 2. AO1 minimum is set to 0 mA by parameter 15.03. 3. The measured maximum motor current is scaled to correspond to a 20 mA analogue output signal by setting the scaling factor (k) to 150%. The value is defined as follows: The reference value of the output signal CURRENT is the motor nominal current i.e. 7.5 A (see parameter 15.01). To make the measured maximum motor current correspond to 20 mA, it should be scaled equally to the reference value before it is converted to an analogue output signal. <p>Equation: $k \times 5 \text{ A} = 7.5 \text{ A} \Rightarrow k = 1.5 = 150\%$</p> 	100 ... 10000
15.06	ANALOGUE OUTPUT2	See parameter 15.01 .	
	NOT USED	See parameter 15.01 .	1
	SPEED	See parameter 15.01 .	2
	FREQUENCY	See parameter 15.01 .	3
	CURRENT	See parameter 15.01 .	4
	TORQUE	See parameter 15.01 .	5
	POWER	See parameter 15.01 .	6
	DC BUS VOLT	See parameter 15.01 .	7
	OUTPUT VOLT	See parameter 15.01 .	8
	REFERENCE	See parameter 15.01 .	9
	CONTROL DEV	See parameter 15.01 .	10
	ACTUAL 1	See parameter 15.01 .	11
	ACTUAL 2	See parameter 15.01 .	12
	PICON OUTP	See parameter 15.01 .	13
	PICON REF	See parameter 15.01 .	14
	ACTUAL FUNC	See parameter 15.01 .	15
	COMM MODULE	The value is read from fieldbus reference REF5. See Fieldbus control .	16
	AO2 PTR	Source selected by parameter 15.12 .	17
15.07	INVERT AO2	See parameter 15.02 .	
	NO	See parameter 15.02 .	0
	YES	See parameter 15.02 .	65535
15.08	MINIMUM AO2	See parameter 15.03 .	
	0 mA	See parameter 15.03 .	1
	4 mA	See parameter 15.03 .	2
15.09	FILTER AO2	See parameter 15.04 .	
	0.00 ... 10.00 s	See parameter 15.04 .	0 ... 1000
15.10	SCALE AO2	See parameter 15.05 .	
	10 ... 1000%	See parameter 15.05 .	100 ... 10000

Index	Name/Selection	Description	FbEq
15.11	AO1 PTR	Defines the source or constant for value AO1 PTR of parameter 15.01 .	1000 = 1 mA
	-255.255.31 ... +255.255.31 / C.-32768 ... C.32767	Parameter index or a constant value. See Parameter 10.04 for information on the difference.	-
15.12	AO2 PTR	Defines the source or constant for value AO2 PTR of parameter 15.06 .	1000 = 1 mA
	-255.255.31 ... +255.255.31 / C.-32768 ... C.32767	Parameter index or a constant value. See Parameter 10.04 for information on the difference.	-
16 SYSTEM CTR INPUT		Run Enable, parameter lock etc.	
16.01	RUN ENABLE	Sets the Run Enable signal on, or selects a source for the external Run Enable signal. If Run Enable signal is switched off, the drive will not start or stops if it is running. The stopping mode is selected by parameter 21.07 .	
	YES	Run Enable signal is on.	1
	DI1	External signal required through digital input DI1. 1 = Run Enable.	2
	DI2	See selection DI1.	3
	DI3	See selection DI1.	4
	DI4	See selection DI1.	5
	DI5	See selection DI1.	6
	DI6	See selection DI1.	7
	DI7	See selection DI1.	8
	DI8	See selection DI1.	9
	DI9	See selection DI1.	10
	DI10	See selection DI1.	11
	DI11	See selection DI1.	12
	DI12	See selection DI1.	13
	COMM.MODULE	External signal required through the Fieldbus Control Word (bit 3).	14
	RUN ENA PTR	Source selected by parameter 16.08 .	15
16.02	PARAMETER LOCK	Selects the state of the parameter lock. The lock prevents parameter changing.	
	OPEN	The lock is open. Parameter values can be changed.	0
	LOCKED	Locked. Parameter values cannot be changed from the control panel. The lock can be opened by entering the valid code at parameter 16.03 .	65535
16.03	PASS CODE	Selects the pass code for the parameter lock (see parameter 16.02).	
	0 ... 30000	Setting 358 opens the lock. The value will automatically revert to 0.	0 ... 30000
16.04	FAULT RESET SEL	Selects the source for the fault reset signal. The signal resets the drive after a fault trip if the cause of the fault no longer exists.	
	NOT SEL	Fault reset only from the control panel keypad (RESET key).	1
	DI1	Reset through digital input DI1 or by control panel: - If the drive is in external control mode: Reset by a rising edge of DI1. - If the drive is in local control mode: Reset by the RESET key of the control panel.	2
	DI2	See selection DI1.	3
	DI3	See selection DI1.	4
	DI4	See selection DI1.	5

Index	Name/Selection	Description	FbEq
	DI5	See selection DI1.	6
	DI6	See selection DI1.	7
	DI7	See selection DI1.	8
	DI8	See selection DI1.	9
	DI9	See selection DI1.	10
	DI10	See selection DI1.	11
	DI11	See selection DI1.	12
	DI12	See selection DI1.	13
	ON STOP	Reset along with the stop signal received through a digital input, or by the RESET key of the control panel.	14
	COMM.MODULE	Reset through the fieldbus Control Word (bit 7), or by the RESET key of the control panel.	15
	FLT RST PTR	Source defined by parameter 16.10 .	16
16.05	USER MACRO IO CHG	<p>Enables the change of the User Macro through a digital input. See parameter 99.02. The change is only allowed when the drive is stopped. During the change, the drive will not start.</p> <p>Note: Always save the User Macro by parameter 99.02 after changing any parameter settings, or reperforming the motor identification. <u>The last settings saved by the user are loaded into use whenever the power is switched off and on again or the macro is changed. Any unsaved changes will be lost.</u></p> <p>Note: The value of this parameter is not included in the User Macro. A setting once made remains despite the User Macro change.</p> <p>Note: Selection of User Macro 2 can be supervised via relay output RO3. See parameter 14.03 for more information.</p>	
	NOT SEL	User macro change is not possible through a digital input.	1
	DI1	Falling edge of digital input DI1: User Macro 1 is loaded into use. Rising edge of digital input DI1: User Macro 2 is loaded into use.	2
	DI2	See selection DI1.	3
	DI3	See selection DI1.	4
	DI4	See selection DI1.	5
	DI5	See selection DI1.	6
	DI6	See selection DI1.	7
	DI7	See selection DI1.	8
	DI8	See selection DI1.	9
	DI9	See selection DI1.	10
	DI10	See selection DI1.	11
	DI11	See selection DI1.	12
	DI12	See selection DI1.	13
16.06	LOCAL LOCK	<p>Disables entering local control mode (<i>LOC/REM</i> key of the panel).</p> <p> WARNING! Before activating, ensure that the control panel is not needed for stopping the drive!</p>	
	FALSE	Local control allowed.	0
	TRUE	Local control disabled.	65535

Index	Name/Selection	Description	FbEq
16.07	PARAMETER BACKUP	Saves the valid parameter values to the permanent memory. Note: A new parameter value of a standard macro is saved automatically when changed from the panel but not when altered through a fieldbus connection.	
	DONE	Save completed.	0
	SAVE..	Save in progress.	1
16.08	RUN ENA PTR	Defines the source or constant for value RUN ENA PTR of parameter 16.01 .	
	-255.255.31 ... +255.255.31 / C.-32768 ... C.32767	Parameter index or a constant value. See Parameter 10.04 for information on the difference.	-
16.09	CTRL BOARD SUPPLY	Defines the source of the control board power supply. Note: If an external supply is used but this parameter has the value INTERNAL, the drive trips on a fault at power switch-off.	
	INTERNAL 24V	Internal (default).	1
	EXTERNAL 24V	External. The control board is powered from an external supply.	2
16.10	FAULT RESET PTR	Defines the source or constant for value FLT RST PTR of parameter 16.04 .	
	-255.255.31 ... +255.255.31 / C.-32768 ... C.32767	Parameter index or a constant value. See Parameter 10.04 for information on the difference.	-
16.12	RESET COUNTER	Resets the cooling fan running time counter or kWh counter.	
	NO	No reset	0
	FAN ON-TIME	Resets the running time counter of the drive cooling fan indicated with 01.44 .	1
	kWh	kWh counter reset. See parameter 01.15 .	2
20 LIMITS		Drive operation limits.	
20.01	MINIMUM FREQ	Defines the allowed minimum frequency. If the value is positive, the motor will not run in the reverse direction.  Note: The limit is linked to the motor nominal frequency setting i.e. parameter 99.07 . If 99.07 is changed, the default frequency limit will also change.	
	-120.00 Hz ... 120.00 Hz	Minimum frequency limit.	-12000 ... 12000
20.02	MAXIMUM FREQ	Defines the allowed maximum frequency.  Note: The limit is linked to the motor nominal speed setting i.e. parameter 99.08 . If 99.08 is changed, the default speed limit will also change.	
	-120.00 Hz ... 120.00 Hz	Maximum frequency limit.	-12000 ... 12000
20.03	MAXIMUM CURRENT A	Defines the allowed maximum motor current in amperes.	
	0.0 ... (depends on drive type)	Current limit	10 = 1 A
20.04	MAXIMUM TORQUE	Defines the maximum torque limit for the drive.	
	0.0 ... 600.0%	Value of limit in percent of motor nominal torque.	0 ... 60000
20.05	OVERVOLTAGE CTL	Activates or deactivates the overvoltage control of the intermediate DC link. Fast braking of a high inertia load causes the voltage to rise to the overvoltage control limit. To prevent the DC voltage from exceeding the limit, the overvoltage controller automatically decreases the braking torque. Note: The controller must be OFF to allow chopper operation.	

Index	Name/Selection	Description	FbEq
	OFF	Overvoltage control deactivated.	0
	ON	Overvoltage control activated.	65535
20.06	UNDERVOLTAGE CTL	Activates or deactivates the undervoltage control of the intermediate DC link. If the DC voltage drops due to input power cut off, the undervoltage controller will automatically decrease the motor speed in order to keep the voltage above the lower limit. By decreasing the motor speed, the inertia of the load will cause regeneration back into the drive, keeping the DC link charged and preventing an undervoltage trip until the motor coasts to stop. This will act as a power-loss ride-through functionality in systems with a high inertia, such as a centrifuge or a fan.	
	OFF	Undervoltage control deactivated.	0
	ON	Undervoltage control activated.	65535
20.07	PI MIN FREQ	Minimum frequency for the PI controller. Typically, this value corresponds to the frequency at the lower end of the pump performance curve.	
	-120.00 Hz ... 120.00 Hz	Minimum frequency for the PI controller.	-12000 ... 12000
20.11	P MOTORING LIM	Defines the allowed maximum power fed by the inverter to the motor.	
	0.0 ... 600.0%	Power limit in percent of the motor nominal power	0 ... 60000
20.12	P GENERATING LIM	Defines the allowed maximum power fed by the motor to the inverter.	
	-600.0 ... 0.0%	Power limit in percent of the motor nominal power	-60000 ... 0
21 START/STOP		Start and stop modes of the motor.	
21.01	START FUNCTION	Selects the motor starting method.	
	AUTO	Automatic start guarantees optimal motor start in most cases. It includes the flying start function (starting to a rotating machine) and the automatic restart function (stopped motor can be restarted immediately without waiting the motor flux to die away). The drive motor control program identifies the flux as well as the mechanical state of the motor and starts the motor instantly under all conditions. Note: If parameter 99.04 = SCALAR, no flying start or automatic restart is possible by default. The flying start feature needs to be activated separately by parameter 21.08.	1
	DC MAGN	DC magnetising should be selected if a high break-away torque is required. The drive pre-magnetises the motor before the start. The pre-magnetising time is determined automatically, being typically 200 ms to 2 s depending on the motor size. DC MAGN guarantees the highest possible break-away torque. Note: Starting to a rotating machine is not possible when DC magnetising is selected. Note: DC magnetising cannot be selected if parameter 99.04 = SCALAR.	2

Index	Name/Selection	Description	FbEq								
	CNST DC MAGN	<p>Constant DC magnetising should be selected instead of DC magnetising if constant pre-magnetising time is required (e.g. if the motor start must be simultaneous with a mechanical brake release). This selection also guarantees the highest possible break-away torque when the pre-magnetising time is set long enough. The pre-magnetising time is defined by parameter 21.02.</p> <p>Note: Starting to a rotating machine is not possible when DC magnetising is selected.</p> <p>Note: DC magnetising cannot be selected if parameter 99.04 = SCALAR.</p> <p> WARNING! The drive will start after the set magnetising time has passed although the motor magnetisation is not completed. Ensure always in applications where a full break-away torque is essential, that the constant magnetising time is long enough to allow generation of full magnetisation and torque.</p>	3								
21.02	CONST MAGN TIME	Defines the magnetising time in the constant magnetising mode. See parameter 21.01 . After the start command, the drive automatically pre-magnetises the motor the set time.									
	30.0 ... 10000.0 ms	<p>Magnetising time. To ensure full magnetising, set this value to the same value as or higher than the rotor time constant. If not known, use the rule-of-thumb value given in the table below:</p> <table border="1" data-bbox="544 913 1342 1077"> <thead> <tr> <th>Motor Rated Power</th> <th>Constant Magnetising Time</th> </tr> </thead> <tbody> <tr> <td>< 10 kW</td> <td>≥ 100 to 200 ms</td> </tr> <tr> <td>10 to 200 kW</td> <td>≥ 200 to 1000 ms</td> </tr> <tr> <td>200 to 1000 kW</td> <td>≥ 1000 to 2000 ms</td> </tr> </tbody> </table>	Motor Rated Power	Constant Magnetising Time	< 10 kW	≥ 100 to 200 ms	10 to 200 kW	≥ 200 to 1000 ms	200 to 1000 kW	≥ 1000 to 2000 ms	30 ... 10000
Motor Rated Power	Constant Magnetising Time										
< 10 kW	≥ 100 to 200 ms										
10 to 200 kW	≥ 200 to 1000 ms										
200 to 1000 kW	≥ 1000 to 2000 ms										
21.03	STOP FUNCTION	Selects the motor stop function.									
	COAST	Stop by cutting off the motor power supply. The motor coasts to a stop.	1								
	RAMP	Stop along a ramp (see parameter group 22 ACCEL/DECEL). With the PFC TRAD macro, all auxiliary pumps are stopped first, then the drive stops along the ramp.	2								
21.07	RUN ENABLE FUNC	<p>Stop mode when the Run Enable signal is removed. See parameter 16.01.</p> <p> WARNING! The drive will start after the Run Enable signal is restored if the Start signal remains ON.</p>									
	RAMP STOP	The application program stops the drive along the deceleration ramp defined in group 22 ACCEL/DECEL .	1								
	COAST STOP	The application program stops the drive by cutting off the motor power supply (the inverter IGBTs are blocked). The motor rotates freely until at zero speed.	2								
21.08	SCALAR FLYSTART	Activates the flying start feature in scalar control mode. See parameters 21.01 and 99.04 .									
	OFF	Inactive.	0								
	ON	Active.	1								
21.09	START INTRL FUNC	Defines how the Start Interlock input on RMIO board affects the drive operation.									
	OFF2 STOP	<p>Drive running: 1 = Normal operation. 0 = Stop by coasting.</p> <p>Drive stopped: 1 = Start allowed. 0 = No start allowed.</p> <p>Restart after OFF2 STOP: Input is back to 1 and the drive receives rising edge of the Start signal.</p>	1								

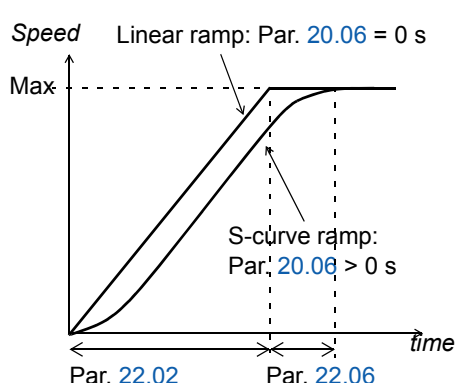

Index	Name/Selection	Description	FbEq
	OFF3 STOP	Drive running: 1 = Normal operation. 0 = Stop by ramp. The ramp time is defined by parameter 22.07 EM STOP RAMP. Drive stopped: 1 = Normal start. 0 = No start allowed. Restart after OFF3 STOP: Start Interlock input = 1 and the drive receives rising edge of the Start signal.	2
22 ACCEL/DECEL		Acceleration and deceleration times.	
22.01	ACC/DEC 1/2 SEL	Selects the active pair of acceleration/deceleration times.	
	ACC/DEC 1	Acceleration time 1 and deceleration time 1 are used. See parameters 22.02 and 22.03.	1
	ACC/DEC 2	Acceleration time 2 and deceleration time 2 are used. See parameters 22.04 and 22.05.	2
	DI1	Acceleration/deceleration time pair selection through digital input DI1. 0 = Acceleration time 1 and deceleration time 1 are in use. 1 = Acceleration time 2 and deceleration time 2 are in use.	3
	DI2	See selection DI1.	4
	DI3	See selection DI1.	5
	DI4	See selection DI1.	6
	DI5	See selection DI1.	7
	DI6	See selection DI1.	8
	DI7	See selection DI1.	9
	DI8	See selection DI1.	10
	DI9	See selection DI1.	11
	DI10	See selection DI1.	12
	DI11	See selection DI1.	13
	DI12	See selection DI1.	14
	ACC/DEC PTR	Acceleration and deceleration times defined by parameters 22.08 and 22.09.	15
22.02	ACCEL TIME 1	Defines acceleration time 1, i.e. the time required for the frequency to change from zero to the maximum frequency. - If the reference increases faster than the set acceleration rate, the motor frequency will follow the acceleration rate. - If the reference increases slower than the set acceleration rate, the motor frequency will follow the reference signal. - If the acceleration time is set too short, the drive will automatically prolong the acceleration in order not to exceed the drive operating limits.	
	0.00 ... 1800.00 s	Acceleration time	0 ... 18000
22.03	DECEL TIME 1	Defines deceleration time 1, i.e. the time required for the frequency to change from the maximum (see parameter 20.02) to zero. - If the reference decreases slower than the set deceleration rate, the motor frequency will follow the reference signal. - If the reference changes faster than the set deceleration rate, the motor frequency will follow the deceleration rate. - If the deceleration time is set too short, the drive will automatically prolong the deceleration in order not to exceed drive operating limits. If there is any doubt about the deceleration time being too short, ensure that the DC overvoltage control is on (parameter 20.05). Note: If a short deceleration time is needed for a high inertia application, the drive should be equipped with an electric braking option e.g. with a brake chopper and a brake resistor.	

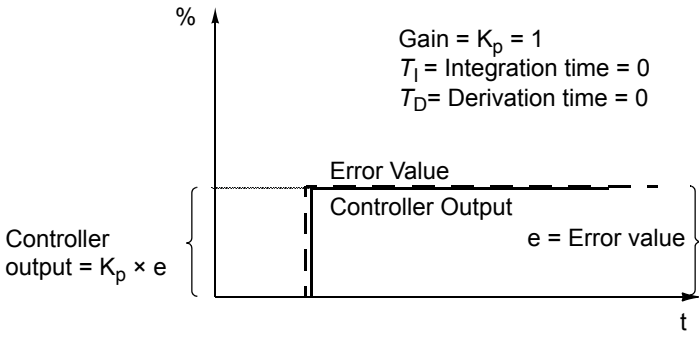
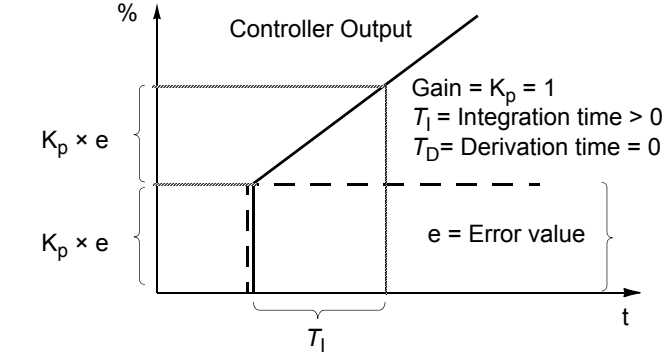

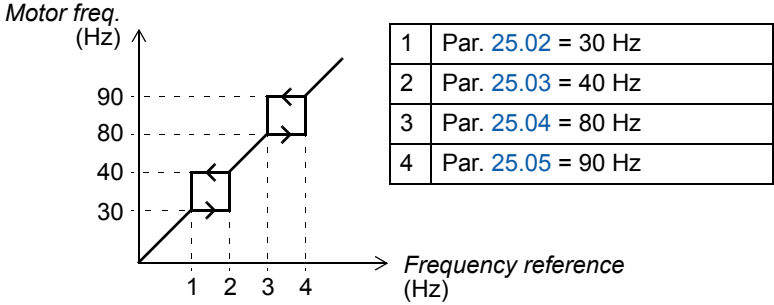
Index	Name/Selection	Description	FbEq
	0.00 ... 1800.00 s	Deceleration time	0 ... 18000
22.04	ACCEL TIME 2	See parameter 22.02.	
	0.00 ... 1800.00 s	See parameter 22.02.	0 ... 18000
22.05	DECEL TIME 2	See parameter 22.02.	
	0.00 ... 1800.00 s	See parameter 22.02.	0 ... 18000
22.06	SHAPE TIME	Selects the shape of the acceleration/deceleration ramp.	
	0.00 ... 1000.00 s	<p>0.00 s: Linear ramp. Suitable for steady acceleration or deceleration and for slow ramps.</p> <p>0.01 ... 1000.00 s: S-curve ramp. S-curve ramps are ideal for conveyors carrying fragile loads, or other applications where a smooth transition is required when changing from one speed to another. The S curve consists of symmetrical curves at both ends of the ramp and a linear part in between.</p> <p>A rule of thumb: A suitable relation between the ramp shape time and the acceleration ramp time is 1/5.</p>  <p>Note: In multimotor applications, the drive switches off the auxiliary motors one by one and ramps down the speed-regulated motor. Depending on the process, this may take more time than specified by this parameter.</p>	0 ... 100000
22.07	STOP RAMP TIME	<p>Defines the time inside which the drive is stopped after an emergency stop command.</p> <p>The emergency stop command can be given through a fieldbus or an Emergency Stop module (optional). Consult the local ABB representative for more information on the optional module and the related parameter settings.</p>	
	0.00 ... 2000.00 s	Deceleration time.	0 ... 200000
22.08	ACC PTR	Defines the source or constant for value ACC/DEC PTR of parameter 22.01 (acceleration).	
	-255.255.31 ... +255.255.31 / C.- 32768 ... C.32767	Parameter index or a constant value. See Parameter 10.04 for information on the difference.	100 = 1 s
22.09	DEC PTR	Defines the source or constant for value ACC/DEC PTR of parameter 22.01 (deceleration).	
	-255.255.31 ... +255.255.31 / C.-32768 ... C.32767	Parameter index or a constant value. See Parameter 10.04 for information on the difference.	100 = 1 s

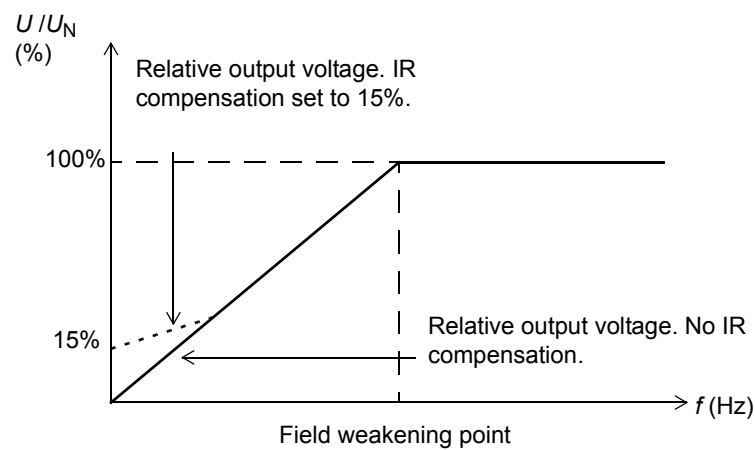
Index	Name/Selection	Description	FbEq
23 SPEED CTRL		Speed controller variables. The parameters are not visible if parameter 99.04 is set to SCALAR.	
23.01	KPS	<p>Defines a relative gain for the speed controller. Great gain may cause speed oscillation.</p> <p>The figure below shows the speed controller output after an error step when the error remains constant.</p>  <p>Gain = $K_p = 1$ $T_I =$ Integration time = 0 $T_D =$ Derivation time = 0</p> <p>Controller output = $K_p \times e$</p>	
	0.0 ... 250.0	Gain.	0 ... 25000
23.02	TIS	<p>Defines an integration time for the speed controller. The integration time defines the rate at which the controller output changes when the error value is constant. The shorter the integration time, the faster the continuous error value is corrected. Too short an integration time makes the control unstable.</p> <p>The figure below shows the speed controller output after an error step when the error remains constant.</p>  <p>Gain = $K_p = 1$ $T_I =$ Integration time > 0 $T_D =$ Derivation time = 0</p>	
	0.01 ... 999.97 s	Integration time	10 ... 999970
23.03	SLIP GAIN	<p>Defines the slip gain for the motor slip compensation control. 100% means full slip compensation; 0% means no slip compensation. The default value is 100%. Other values can be used if a static speed error is detected despite of the full slip compensation.</p> <p><i>Example:</i> A 1000 rpm constant speed reference is given to the drive. Despite full slip compensation (SLIP GAIN = 100%), a manual tachometer measurement from the motor shaft gives a speed value of 998 rpm. The static speed error is 1000 rpm - 998 rpm = 2 rpm. To compensate the error, the slip gain should be increased. With a gain value of 106%, no static speed error exists.</p>	
	0.0 ... 400.0%	Slip gain value.	0 ... 400

Index	Name/Selection	Description	FbEq								
25 CRITICAL FREQ		Frequency bands within which the drive is not allowed to operate.									
25.01	CRIT FREQ SELECT	<p>Activates/deactivates the critical frequencies function.</p> <p><i>Example:</i> A fan has vibration in the ranges of 30 to 40 Hz and 80 to 90 Hz. To make the drive skip the vibration ranges,</p> <ul style="list-style-type: none"> - activate the critical speeds function, - set the critical speed ranges as in the figure below. 									
		 <table border="1" data-bbox="944 571 1332 728"> <tr> <td>1</td> <td>Par. 25.02 = 30 Hz</td> </tr> <tr> <td>2</td> <td>Par. 25.03 = 40 Hz</td> </tr> <tr> <td>3</td> <td>Par. 25.04 = 80 Hz</td> </tr> <tr> <td>4</td> <td>Par. 25.05 = 90 Hz</td> </tr> </table>	1	Par. 25.02 = 30 Hz	2	Par. 25.03 = 40 Hz	3	Par. 25.04 = 80 Hz	4	Par. 25.05 = 90 Hz	
1	Par. 25.02 = 30 Hz										
2	Par. 25.03 = 40 Hz										
3	Par. 25.04 = 80 Hz										
4	Par. 25.05 = 90 Hz										
	OFF	Inactive	0								
	ON	Active.	65535								
25.02	CRIT FREQ 1 LOW	Defines the minimum limit for critical frequency range 1.									
	0 ... 120 Hz	Minimum limit. The value cannot be above the maximum (parameter 25.03).	0 ... 120								
25.03	CRIT FREQ 1 HIGH	Defines the maximum limit for critical frequency range 1.									
	0 ... 120 Hz	Maximum limit. The value cannot be below the minimum (parameter 25.02).	0 ... 120								
25.04	CRIT FREQ 2 LOW	See parameter 25.02.									
	0 ... 120 Hz	See parameter 25.02.	0 ... 120								
25.05	CRIT FREQ 2 HIGH	See parameter 25.03.									
	0 ... 120 Hz	See parameter 25.03.	0 ... 120								
26 MOTOR CONTROL											
26.01	FLUX OPTIMIZATION	<p>Activates/deactivates the flux optimization function.</p> <p>Note: The function cannot be used if parameter 99.04 = SCALAR.</p>									
	NO	Inactive	0								
	YES	Active	65535								
26.02	FLUX BRAKING	<p>Activates/deactivates the flux braking function.</p> <p>Note: The function cannot be used if parameter 99.04 = SCALAR.</p>									
	NO	Inactive	0								
	YES	Active	65535								

Index	Name/Selection	Description	FbEq
26.03	IR COMPENSATION	<p>Defines the relative output voltage boost at zero speed (IR compensation). The function is useful in applications with high break-away torque, but no DTC motor control cannot be applied. The figure below illustrates the IR compensation.</p> <p>Note: The function can be used only if parameter 99.04 is SCALAR.</p> 	
	0 ... 30%	Voltage boost at zero speed in percent of the motor nominal voltage.	0 ... 3000
26.04	HEX FIELD WEAKEN	Selects whether motor flux is controlled along a circular or a hexagonal pattern in the field weakening area of the frequency range (above 50/60 Hz).	
	OFF	The rotating flux vector follows a circular pattern. Optimal selection in most applications: Minimal losses at constant load. Maximal instantaneous torque is not available in the field weakening range of the speed.	0
	ON	Motor flux follows a circular pattern below the field weakening point (typically 50 or 60 Hz) and a hexagonal pattern in the field weakening range. Optimal selection in the applications that require maximal instantaneous torque in the field weakening range of the speed. The losses at constant operation are higher than with the selection OFF.	65535
30 FAULT FUNCTIONS		Programmable protection functions	
30.01	AI<MIN FUNCTION	<p>Selects how the drive reacts when an analogue input signal falls below the set minimum limit.</p> <p>Note: The analogue input minimum setting must be set to 0.5 V (1 mA) or above (see parameter group 13 ANALOGUE INPUTS).</p>	
	FAULT	The drive trips on a fault and the motor coasts to stop.	1
	NO	Inactive	2
	PRESET FREQ	<p>The drive generates a warning AI < MIN FUNC (8110) and sets the frequency to the value defined by parameter 30.18.</p> <p>WARNING! Make sure that it is safe to continue operation in case the analogue input signal is lost.</p>	3
	LAST FREQ	<p>The drive generates a warning AI < MIN FUNC (8110) and freezes the frequency to the level the drive was operating at. The value is determined by the average frequency over the previous 10 seconds.</p> <p>WARNING! Make sure that it is safe to continue operation in case the analogue input signal is lost.</p>	4
30.02	PANEL LOSS	Determines how the drive reacts to a control panel communication break.	
	FAULT	Drive trips on a fault and the motor stops as defined by parameter 21.03.	1

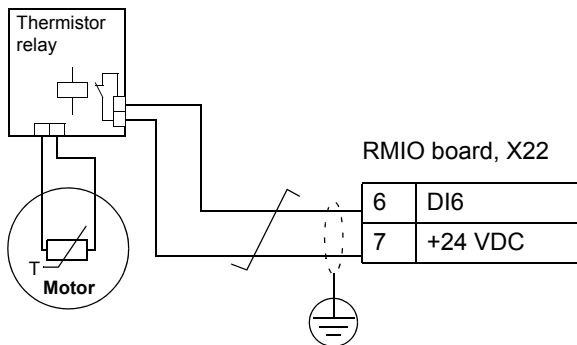
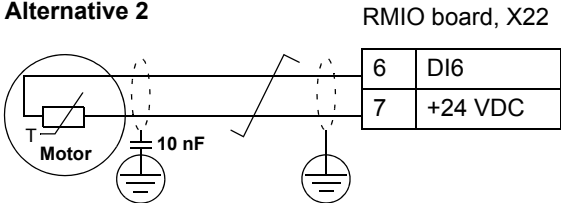

Index	Name/Selection	Description	FbEq
	PRESET FREQ	The drive generates a warning and sets the frequency to the value defined by parameter 30.18 .  WARNING! Make sure that it is safe to continue operation in case the analogue input signal is lost.	2
	LAST FREQ	The drive generates a warning and freezes the frequency to the level the drive was operating at. The value is determined by the average frequency over the previous 10 seconds.  WARNING! Make sure that it is safe to continue operation in case the analogue input signal is lost.	3
30.03	EXTERNAL FAULT	Selects an interface for an external fault signal.	
	NOT SEL	Inactive	1
	DI1	External fault indication is given through digital input DI1. 0: Fault trip. Motor coasts to stop. 1: No external fault.	2
	DI2	See selection DI1 .	3
	DI3	See selection DI1 .	4
	DI4	See selection DI1 .	5
	DI5	See selection DI1 .	6
	DI6	See selection DI1 .	7
	DI7	See selection DI1 .	8
	DI8	See selection DI1 .	9
	DI9	See selection DI1 .	10
	DI10	See selection DI1 .	11
	DI11	See selection DI1 .	12
	DI12	See selection DI1 .	13
30.04	MOT THERM PROT	Selects how the drive reacts when the motor overtemperature is detected by the function defined by Parameter 30.05 .	
	FAULT	The drive generates a warning when the temperature exceeds the warning level (95% of the allowed maximum value). The drive trips on a fault when the temperature exceeds the fault level (100% of the allowed maximum value).	1
	WARNING	The drive generates a warning when the temperature exceeds the warning level (95% of the allowed maximum value).	2
	NO	Inactive	3
30.05	MOTOR THERM PMODE	Selects the thermal protection mode of the motor. When overtemperature is detected, the drive reacts as defined by parameter 30.04 .	

Index	Name/Selection	Description	FbEq
	DTC	<p>The protection is based on the calculated motor thermal model. The following assumptions are used in the calculation:</p> <ul style="list-style-type: none"> - The motor is at ambient temperature (30 °C) when the power is switched on. - The motor temperature increases if it operates in the region above the load curve and decreases if it operates below the curve. - The motor thermal time constant is an approximate value for a standard self-ventilated squirrel-cage motor. <p>It is possible to finetune the model by parameter 30.07.</p> <p>Note: The model cannot be used with high power motors (parameter 99.06 is higher than 800 A).</p> <p> WARNING! The model does not protect the motor if it does not cool properly due to dust and dirt.</p>	1
	USER MODE	<p>The protection is based on the user-defined motor thermal model and the following basic assumptions:</p> <ul style="list-style-type: none"> - The motor is at ambient temperature (30 °C) when power is switched on. - The motor temperature increases if it operates in the region above the motor load curve and decreases if it operates below the curve. <p>The user-defined thermal model uses the motor thermal time constant (parameter 30.06) and the motor load curve (parameters 30.07, 30.08 and 30.09). User tuning is typically needed only if the ambient temperature differs from the normal operating temperature specified for the motor.</p> <p> WARNING! The model does not protect the motor if it does not cool properly due to dust and dirt.</p>	2

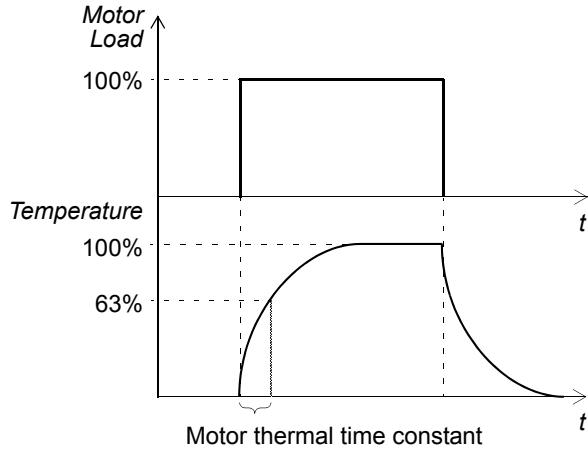
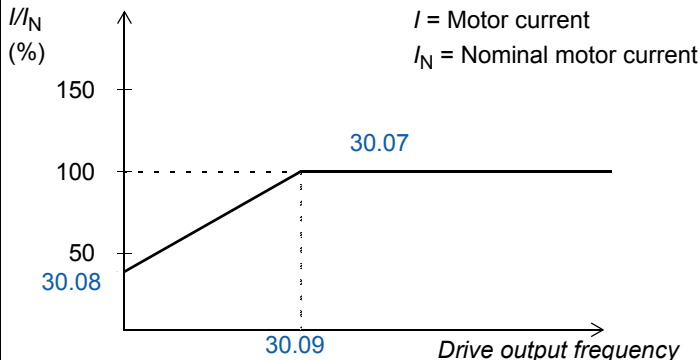
Index	Name/Selection	Description	FbEq						
	THERMISTOR	<p>Motor thermal protection is activated through digital input DI6. A motor thermistor, or a break contact of a thermistor relay, must be connected to digital input DI6. The drive reads the DI6 states as follows:</p> <table border="1" data-bbox="555 414 1302 544"> <thead> <tr> <th>DI6 Status (Thermistor resistance)</th> <th>Temperature</th> </tr> </thead> <tbody> <tr> <td>1 (0 ... 1.5 kohm)</td> <td>Normal</td> </tr> <tr> <td>0 (4 kohm or higher)</td> <td>Overtemperature</td> </tr> </tbody> </table> <p>⚡ WARNING! According to IEC 664, the connection of the motor thermistor to the digital input requires double or reinforced insulation between motor live parts and the thermistor. Reinforced insulation entails a clearance and creeping distance of 8 mm (400 / 500 VAC equipment). If the thermistor assembly does not fulfil the requirement, the other I/O terminals of the drive must be protected against contact, or a thermistor relay must be used to isolate the thermistor from the digital input.</p> <p>⚠ WARNING! Digital input DI6 may be selected for another use. Change these settings before selecting THERMISTOR. In other words, ensure that digital input DI6 is not selected by any other parameter.</p> <p>The figure below shows the alternative thermistor connections. At the motor end the cable shield should be earthed through a 10 nF capacitor. If this is not possible, the shield is to be left unconnected.</p> <p>Alternative 1</p>  <p>Alternative 2</p> 	DI6 Status (Thermistor resistance)	Temperature	1 (0 ... 1.5 kohm)	Normal	0 (4 kohm or higher)	Overtemperature	3
DI6 Status (Thermistor resistance)	Temperature								
1 (0 ... 1.5 kohm)	Normal								
0 (4 kohm or higher)	Overtemperature								

Index	Name/Selection	Description	FbEq
30.06	MOTOR THERM TIME	<p>Defines the thermal time constant for the user-defined thermal model (see the selection USER MODE of parameter 30.05).</p> 	
	256.0 ... 9999.8 s	Time constant	256 ... 9999
30.07	MOTOR LOAD CURVE	<p>Defines the load curve together with parameters 30.08 and 30.09. The load curve is used in the user-defined thermal model (see the selection USER MODE at parameter 30.05).</p> 	
	50.0 ... 150.0%	Allowed continuous motor load in percent of the nominal motor current.	50 ... 150
30.08	ZERO SPEED LOAD	Defines the load curve together with parameters 30.07 and 30.09.	
	25.0 ... 150.0%	Allowed continuous motor load at zero speed in percent of the nominal motor current.	25 ... 150
30.09	BREAK POINT	Defines the load curve together with parameters 30.07 and 30.08.	
	1.0 ... 300.0 Hz	Drive output frequency at 100% load.	100 ... 30000
30.10	STALL FUNCTION	<p>Selects how the drive reacts to a motor stall condition. The protection wakes up if:</p> <ul style="list-style-type: none"> - the motor torque is at the internal stall torque limit (not user-adjustable) - the output frequency is below the level set by parameter 30.11 and - the conditions above have been valid longer than the time set by parameter 30.12. 	
	FAULT	The drive trips on a fault.	1
	WARNING	The drive generates a warning. The indication disappears in half of the time set by parameter 30.12.	2

Index	Name/Selection	Description	FbEq
	NO	Protection is inactive.	3
30.11	STALL FREQ HI	Defines the frequency limit for the stall function. See parameter 30.10.	
	0.5 ... 50.0 Hz	Stall frequency	50 ... 5000
30.12	STALL TIME	Defines the time for the stall function. See parameter 30.10.	
	10.00 ... 400.00 s	Stall time	10 ... 400
30.13	UNDERLOAD FUNCTIO	Selects how the drive reacts to underload. The protection wakes up if: <ul style="list-style-type: none"> - the motor torque falls below the curve selected by parameter 30.15, - output frequency is higher than 10% of the nominal motor frequency and - the above conditions have been valid longer than the time set by parameter 30.14. 	
	NO	Protection is inactive.	1
	WARNING	The drive generates a warning.	2
	FAULT	The drive trips on a fault.	3
30.14	UNDERLOAD TIME	Time limit for the underload function. See parameter 30.13.	
	0 ... 600 s	Underload time.	0 ... 600
30.15	UNDERLOAD CURVE	Selects the load curve for the underload function. See parameter 30.13.	
		<p> T_M/T_N (%) 100 80 60 40 20 0 f_N $2.4 * f_N$ T_M = Motor torque T_N = Nominal motor torque f_N = Nominal motor frequency </p>	
	1 ... 5	Number of the load curve.	1 ... 5
30.16	MOTOR PHASE LOSS	Activates the motor phase loss supervision function.	
	NO	Inactive.	0
	FAULT	Active. The drive trips on a fault.	65535
30.17	EARTH FAULT	Selects how the drive reacts when an earth fault is detected in the motor or the motor cable.	
	WARNING	The drive generates a warning.	0
	FAULT	The drive trips on a fault.	65535
30.18	PRESET FREQ	Used as a reference when a fault occurs and the fault function is set to preset frequency.	
	0.00 ... 120.00 Hz	Preset frequency.	0 ... 120

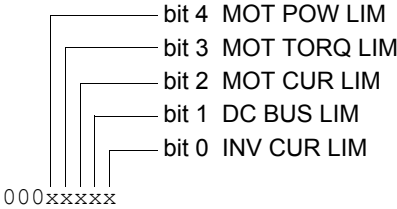
Index	Name/Selection	Description	FbEq
30.19	COMM FAULT FUNC	Selects how the drive reacts in a fieldbus communication break, i.e. when the drive fails to receive the Main Reference Data Set or the Auxiliary Reference Data Set. The time delays are given by parameters 30.20 and 30.21.	
	FAULT	Protection is active. The drive trips on a fault and stops the motor as defined by parameter 21.03.	1
	NO	Protection is inactive.	2
	PRESET FREQ	Protection is active. The drive generates a warning and sets the frequency to the value defined by parameter 30.18.  WARNING! Make sure that it is safe to continue operation in case of a communication break.	3
	LAST FREQ	Protection is active. The drive generates a warning and freezes the frequency to the level the drive was operating at. The value is determined by the average frequency over the previous 10 seconds.  WARNING! Make sure that it is safe to continue operation in case of a communication break.	4
30.20	MAIN REF DS T-OUT	Defines the time delay for the Main Reference Dataset supervision. See parameter 30.19.	
	0.10 ... 60.00 s	Time delay	10 ... 6000
30.21	COMM FAULT RO/AO	Selects the operation of the fieldbus controlled relay output and analogue output in a communication break. See groups 14 RELAY OUTPUTS and 15 ANALOGUE OUTPUTS and the chapter <i>Fieldbus control</i> . The delay for the supervision function is given by parameter 30.22.	
	ZERO	Relay output is de-energised. Analogue output is set to zero.	0
	LAST VALUE	The relay output keeps the last state before the communication loss. The analogue output gives the last value before the communication loss.  WARNING! After the communication recovers, the update of the relay and the analogue outputs starts immediately without fault message resetting.	65535
30.22	AUX REF DS T-OUT	Defines the delay time for the Auxiliary Reference Dataset supervision. See parameter 30.19. The drive automatically activates the supervision 60 seconds after power switch-on if the value is other than zero. Note: The delay also applies for the function defined by parameter 30.21.	
	0.00 ... 60.00 s	Time delay. 0.00 s = The function is inactive.	0 ... 6000
30.23	LIMIT WARNING	Activates/deactivates limit warnings INV CUR LIM, DC BUS LIM, MOT CUR LIM, MOT TORQ LIM and MOT POW LIM. For more information, see the chapter <i>Fault tracing</i> .	
	000000 ... 11111111	Each of the above warnings is represented by a bit in a binary number as shown below. To activate a limit monitoring, set its bit to 1. 	

Index	Name/Selection	Description	FbEq
31 AUTOMATIC RESET		Automatic fault reset. Automatic resets are possible only for certain fault types and when the automatic reset function is activated for that fault type. The automatic reset function is not operational if the drive is in local control (L visible on the first row of the panel display).	
31.01	NUMBER OF TRIALS	Defines the number of automatic fault resets the drive performs within the time defined by parameter 31.02.	
	0 ... 5	Number of automatic resets.	0 ... 5
31.02	TRIAL TIME	Defines the time for the automatic fault reset function. See parameter 31.01.	
	1.0 ... 180.0 s	Allowed resetting time.	100 ... 18000
31.03	DELAY TIME	Defines the time that the drive will wait after a fault before attempting an automatic reset. See parameter 31.01.	
	0.0 ... 3.0 s	Resetting delay.	0 ... 300
31.04	OVERCURRENT	Activates/deactivates the automatic reset for the overcurrent fault.	
	NO	Inactive.	0
	YES	Active.	65535
31.05	OVERVOLTAGE	Activates/deactivates the automatic reset for the intermediate link overvoltage fault.	
	NO	Inactive.	0
	YES	Active.	65535
31.06	UNDERVOLTAGE	Activates/deactivates the automatic reset for the intermediate link undervoltage fault.	
	NO	Inactive.	0
	YES	Active.	65535
31.07	AI SIGNAL<MIN	Activates/deactivates the automatic reset for the fault AI SIGNAL<MIN (analogue input signal under the allowed minimum level).	
	NO	Inactive.	0
	YES	Active.  WARNING! The drive may restart even after a long stop if the analogue input signal is restored. Ensure that the use of this feature will not cause danger.	65535
32 SUPERVISION		Supervision limits. A relay output can be used to indicate when the value is above/below the limit.	
32.01	FREQ1 FUNCTION	Activates/deactivates the frequency supervision function and selects the type of the supervision limit.	
	NO	Supervision is not used.	1
	LOW LIMIT	Supervision wakes up if the value is below the limit.	2
	HIGH LIMIT	Supervision wakes up if the value is above the limit.	3

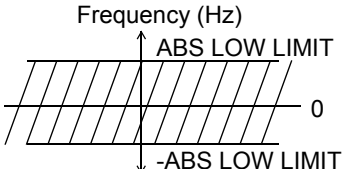
Index	Name/Selection	Description	FbEq
	ABS LOW LIM	Supervision wakes up if the value is below the set limit. The limit is supervised in both rotating directions. The figure below illustrates the principle. 	4
32.02	FREQ1 LIMIT	Defines the frequency supervision limit. See parameter 32.01.	
	-120 ... 120 Hz	Value of the limit.	-120 ... 120
32.03	FREQ2 FUNCTION	See parameter 32.01.	
	NO	See parameter 32.01.	1
	LOW LIMIT	See parameter 32.01.	2
	HIGH LIMIT	See parameter 32.01.	3
	ABS LOW LIM	See parameter 32.01.	4
32.04	FREQ2 LIMIT	See parameter 32.01.	
	-120 ... 120 Hz	See parameter 32.01.	-120 ... 120
32.05	CURRENT FUNCTION	Activates/deactivates the motor current supervision function and selects the type of the supervision limit.	
	NO	See parameter 32.01.	1
	LOW LIMIT	See parameter 32.01.	2
	HIGH LIMIT	See parameter 32.01.	3
32.06	CURRENT LIMIT	Defines the limit for the motor current supervision (see parameter 32.05).	
	0 ... 1000 A	Value of the limit.	0 ... 1000
32.07	REF1 FUNCTION	Activates/deactivates the reference REF1 supervision function and selects the type of the supervision limit.	
	NO	See parameter 32.01.	1
	LOW LIMIT	See parameter 32.01.	2
	HIGH LIMIT	See parameter 32.01.	3
32.08	REF1 LIMIT	Defines the limit for the reference REF1 supervision (see parameter 32.07).	
	0 ... 120 Hz	Value of the limit.	0 ... 120
32.09	REF2 FUNCTION	Activates/deactivates the reference REF2 supervision function and selects the type of the supervision limit.	
	NO	See parameter 32.01.	1
	LOW LIMIT	See parameter 32.01.	2
	HIGH LIMIT	See parameter 32.01.	3
32.10	REF2 LIMIT	Defines the limit for the reference REF2 supervision (see parameter 32.09).	
	0 ... 500%	Value of the limit in percent of motor nominal torque.	0 ... 5000
32.11	ACT1 FUNCTION	Activates/deactivates the supervision function for variable ACT1 of the process PI controller and selects the type of the supervision limit.	
	NO	See parameter 32.01.	1
	LOW LIMIT	See parameter 32.01.	2
	HIGH LIMIT	See parameter 32.01.	3
32.12	ACT1 LIMIT	Defines the limit for ACT1 supervision (see parameter 32.11).	

Index	Name/Selection	Description	FbEq
	0 ... 200%	Value of the limit	0 ... 2000
32.13	ACT2 FUNCTION	Activates/deactivates the supervision function for variable ACT2 of the process PI controller and selects the type of the supervision limit.	
	NO	See parameter 32.01.	1
	LOW LIMIT	See parameter 32.01.	2
	HIGH LIMIT	See parameter 32.01.	3
32.14	ACT2 LIMIT	Defines the limit for ACT2 supervision (see parameter 32.13).	
	0 ... 200%	Value of the limit	0 ... 2000
32.15	RESET START CNT	Resets the drive start counter (actual signal 01.48).	
	NO	No reset.	
	YES	Reset. The counter restarts from zero.	
33 INFORMATION		Program versions, test date	
33.01	SW PACKAGE VER	Displays the type and the version of the firmware package in the drive.	
		Decoding key: <div style="text-align: right; margin-right: 100px;"> AHxx7xyx </div> <p>Product Series _____</p> <p>A = ACS800</p> <p>Product _____</p> <p>H = ACS800 Pump Control Application Program</p> <p>Firmware Version _____</p> <p>7xyx = Version 7.xyx</p>	
33.02	APPLIC NAME	Displays the type and the version of the application program.	
		Decoding key: <div style="text-align: right; margin-right: 100px;"> AHAx7xyx </div> <p>Product Series _____</p> <p>A = ACS800</p> <p>Product _____</p> <p>H = ACS800 Pump Control Application Program</p> <p>Firmware Type _____</p> <p>A = Application Program</p> <p>Firmware Version _____</p> <p>7xyx = Version 7.xyx</p>	
33.03	TEST DATE	Displays the test date.	
		Date value in format DDMMYY (day, month, year)	
40 PI-CONTROLLER		Process PI control (parameter 99.02 = PFC TRAD)	
40.01	PI GAIN	Defines the gain of the process PI controller.	

Index	Name/Selection	Description	FbEq												
0.1 ... 100.0		<p>Gain value. The table below lists a few examples of the gain settings and the resulting PI controller output changes when</p> <ul style="list-style-type: none"> - a 10% or 50% error value is connected to the controller (error = process reference - process actual value). - motor maximum frequency is 60 Hz (Parameter 20.02) <table border="1" style="margin-left: auto; margin-right: auto;"> <thead> <tr> <th>PI Gain</th> <th>PI Output Change: 10% Error</th> <th>PI Output Change: 50% Error</th> </tr> </thead> <tbody> <tr> <td>0.5</td> <td>3 Hz ($0.5 \times 0.1 \times 60$ Hz)</td> <td>15 Hz ($0.5 \times 0.5 \times 60$ Hz)</td> </tr> <tr> <td>1.0</td> <td>6 Hz ($1.0 \times 0.1 \times 60$ Hz)</td> <td>30 Hz ($1.0 \times 0.5 \times 60$ Hz)</td> </tr> <tr> <td>3.0</td> <td>18 Hz ($3.0 \times 0.1 \times 60$ Hz)</td> <td>60 Hz ($> 3.0 \times 0.5 \times 60$ Hz) (limited)</td> </tr> </tbody> </table>	PI Gain	PI Output Change: 10% Error	PI Output Change: 50% Error	0.5	3 Hz ($0.5 \times 0.1 \times 60$ Hz)	15 Hz ($0.5 \times 0.5 \times 60$ Hz)	1.0	6 Hz ($1.0 \times 0.1 \times 60$ Hz)	30 Hz ($1.0 \times 0.5 \times 60$ Hz)	3.0	18 Hz ($3.0 \times 0.1 \times 60$ Hz)	60 Hz ($> 3.0 \times 0.5 \times 60$ Hz) (limited)	10 ... 10000
PI Gain	PI Output Change: 10% Error	PI Output Change: 50% Error													
0.5	3 Hz ($0.5 \times 0.1 \times 60$ Hz)	15 Hz ($0.5 \times 0.5 \times 60$ Hz)													
1.0	6 Hz ($1.0 \times 0.1 \times 60$ Hz)	30 Hz ($1.0 \times 0.5 \times 60$ Hz)													
3.0	18 Hz ($3.0 \times 0.1 \times 60$ Hz)	60 Hz ($> 3.0 \times 0.5 \times 60$ Hz) (limited)													
40.02	PI INTEG TIME	<p>Defines the integration time for the process PI controller.</p> <div style="text-align: center;"> <p style="text-align: right;"> I = controller input (error) O = controller output G = gain t = time Ti = integration time </p> </div>													
0.50 ... 1000.00 s		Integration time	50 ... 100000												
40.03	ERROR VALUE INV	Inverts the error at the process PI controller input (error = process reference - process actual value).													
	NO	No inversion	0												
	YES	Inversion	65535												
40.04	ACTUAL VALUE SEL	<p>Selects the process actual value for the process PI controller: The sources for the variable ACT1 and ACT2 are further defined by parameters 40.05 and 40.06. The result of the calculation is available as actual signal 01.27.</p> <p>Use the sqrt(A1-A2) or sqA1+sqA2 function if the PI controller controls flow with a pressure transducer measuring the pressure difference over a flow meter.</p>													
	ACT1	ACT1	1												
	ACT1 - ACT2	Subtraction of ACT1 and ACT 2.	2												
	ACT1 + ACT2	Addition of ACT1 and ACT2.	3												
	ACT1 * ACT2	Multiplication of ACT1 and ACT2.	4												
	ACT1 / ACT2	Division of ACT1 and ACT2.	5												
	MIN[A1.A2]	Selects the smaller of ACT1 and ACT2.	6												
	MAX[A1.A2]	Selects the greater of ACT1 and ACT2.	7												
	SQRT[A1-A2]	Square root of subtraction of ACT1 and ACT2.	8												
	SQA1 + SQA2	Addition of square root of ACT1 and square root of ACT2.	9												
40.05	ACTUAL1 INPUT SEL	Selects the source for the variable ACT1. See parameter 40.04 .													
	NO	No source selected.	1												

Index	Name/Selection	Description	FbEq						
	AI1	Analogue input AI1.	2						
	AI2	Analogue input AI2.	3						
	AI3	Analogue input AI3.	4						
	ACT1 POINTER	Source selected by parameter 40.16.	5						
	AI5	Analogue input AI5.	6						
	AI6	Analogue input AI6.	7						
40.06	ACTUAL2 INPUT SEL	Selects the source for the variable ACT2. See parameter 40.04.							
	NO	No source selected.	1						
	AI1	Analogue input AI1.	2						
	AI2	Analogue input AI2.	3						
	AI3	Analogue input AI3.	4						
	AI5	Analogue input AI5.	5						
	AI6	Analogue input AI6.	6						
40.07	ACT1 MINIMUM	Defines the minimum value for the variable ACT1 if an analogue input is selected as a source for ACT1. See parameter 40.05. The minimum and maximum (40.08) settings of ACT1 define how the voltage/current signal received from the measuring device is converted to a percentage value used by the process PI controller.							
	-1000 ... 1000%	<p>Minimum value in percent of the set analogue input range. The equation below shows how to calculate the value when analogue input AI1 is used as a variable ACT1.</p> $\text{ACT1 MINIMUM} = \frac{\text{AI1min} - 13.01}{13.02 - 13.01} \times 100\%$ <table border="1" data-bbox="536 1200 1358 1379"> <tr> <td>AI1min</td> <td>The voltage value received from the measuring device when the measured process actual value is at the desired minimum level.</td> </tr> <tr> <td>13.01</td> <td>AI1 minimum (parameter setting)</td> </tr> <tr> <td>13.02</td> <td>AI1 maximum (parameter setting)</td> </tr> </table> <p><i>Example:</i> The pressure of a pipe system is to be controlled between 0 and 10 bar. The pressure transducer has an output range of 4 to 8 V, corresponding to pressure between 0 and 10 bar. The minimum output voltage of the transducer is 2 V and the maximum is 10 V, so the minimum and the maximum of the analogue input is set to 2 V and 10 V. ACT1 MINIMUM is calculated as follows:</p> $\text{ACT1 MINIMUM} = \frac{4 \text{ V} - 2 \text{ V}}{10 \text{ V} - 2 \text{ V}} \times 100\% = 25\%$	AI1min	The voltage value received from the measuring device when the measured process actual value is at the desired minimum level.	13.01	AI1 minimum (parameter setting)	13.02	AI1 maximum (parameter setting)	-1000 ... 1000
AI1min	The voltage value received from the measuring device when the measured process actual value is at the desired minimum level.								
13.01	AI1 minimum (parameter setting)								
13.02	AI1 maximum (parameter setting)								
40.08	ACT1 MAXIMUM	Defines the maximum value for the variable ACT1 if an analogue input is selected as a source for ACT1. See parameter 40.07. The minimum (40.09) and maximum settings of ACT1 define how the voltage/current signal received from the measuring device is converted to a percentage value used by the process PI controller.							



Index	Name/Selection	Description	FbEq						
	-1000 ... 1000%	<p>Maximum value in percent of the set analogue input signal range. The equation below instructs how to calculate the value when analogue input AI1 is used as a variable ACT1.</p> $\text{ACT1 MAXIMUM} = \frac{\text{AI1max} - 13.01}{13.02 - 13.01} \times 100\%$ <table border="1"> <tr> <td>AI1max</td> <td>The voltage value received from the measuring device when the measured process actual value is at the desired maximum level.</td> </tr> <tr> <td>13.01</td> <td>AI1 minimum (parameter setting)</td> </tr> <tr> <td>13.02</td> <td>AI1 maximum (parameter setting)</td> </tr> </table> <p><i>Example:</i> See parameter 40.07. ACT1 MAXIMUM is calculated as follows:</p> $\text{ACT1 MAXIMUM} = \frac{8 \text{ V} - 2 \text{ V}}{10 \text{ V} - 2 \text{ V}} \times 100\% = 75\%$	AI1max	The voltage value received from the measuring device when the measured process actual value is at the desired maximum level.	13.01	AI1 minimum (parameter setting)	13.02	AI1 maximum (parameter setting)	-1000 ... 1000
AI1max	The voltage value received from the measuring device when the measured process actual value is at the desired maximum level.								
13.01	AI1 minimum (parameter setting)								
13.02	AI1 maximum (parameter setting)								
40.09	ACT2 MINIMUM	See parameter 40.07.							
	-1000 ... 1000%	See parameter 40.07.	-1000 ... 1000						
40.10	ACT2 MAXIMUM	See parameter 40.08.							
	-1000 ... 1000%	See parameter 40.08.	-1000 ... 1000						
40.11	ACT1 UNIT SCALE	Matches actual value 1 displayed on the control panel and the unit defined by parameter 40.12.							
	-100000.00 ... 100000.00	Actual value 1 scaling.	-1000000 ... 1000000						
40.12	ACTUAL 1 UNIT	Selects the unit of actual value 1.							
	NO		1						
	bar		2						
	%		3						
	C		4						
	mg/l		5						
	kPa		6						
40.13	ACT2 UNIT SCALE	Matches actual value 2 displayed on the control panel and the unit defined by parameter 40.14.							
	-100000.00 ... 100000.00	Actual value 2 scaling.	-1000000 ... 1000000						
40.14	ACTUAL 2 UNIT	Selects the unit of actual value 2.							
	NO		1						
	bar		2						
	%		3						
	C		4						
	mg/l		5						

Index	Name/Selection	Description	FbEq
	kPa		6
40.15	ACTUAL FUNC SCALE	Scales the result of the arithmetic operation selected by parameter 40.04. The scaled value can be read through an analogue output (see parameter 15.01).	
	-100000.00 ... 100000.00	Scaling for the ACTUAL FUNC signal.	-1000000 ... 1000000
40.16	ACTUAL1 PTR	Defines the source or constant for value ACT1 POINTER of parameter 40.05.	
	-255.255.31 ... +255.255.31 / C.-32768 ... C.32767	Parameter index or a constant value. See Parameter 10.04 for information on the difference.	
41 PFC-CONTROL 1		Process references, start/stop frequencies for auxiliary motors or follower drives. Only visible and effective when either the PFC TRAD or Multipump macro is selected.	
41.01	SET POINT 1/2 SEL	Defines the source from which the drive reads the signal that selects between the two process references. See also parameters 41.02, 41.03 and 41.04.	
	SET POINT 1	Process reference 1 selected.	1
	SET POINT 2	Process reference 2 selected.	2
	DI1	Digital input DI1. 0 = Process reference 1, 1 = Process reference 2.	3
	DI2	See selection DI1.	4
	DI3	See selection DI1.	5
	DI4	See selection DI1.	6
	DI5	See selection DI1.	7
	DI6	See selection DI1.	8
	DI7	See selection DI1.	9
	DI8	See selection DI1.	10
	DI9	See selection DI1.	11
	DI10	See selection DI1.	12
	DI11	See selection DI1.	13
	DI12	See selection DI1.	14
41.02	SET POINT 1 SRCE	Selects the source of process reference 1.	
	EXTERNAL	Process reference 1 is read from the source defined with parameter 11.06. The control panel must be in external control mode (an "R" or a blank space displayed; see <i>Status row</i> on page 22). If the control panel is in local mode (an "L" displayed), the panel gives a direct frequency reference and the PFC logic is bypassed.	0
	INTERNAL	Process reference 1 is a constant value set by parameter 41.03.	65535
41.03	SPOINT 1 INTERNAL	Defines process reference 1 when parameter 41.02 is set to INTERNAL.	
	0.0 ... 100.0%	Internal process reference 1.	0 ... 10000
41.04	SPOINT 2 INTERNAL	Defines process reference 2.	
	0.0 ... 100.0%	Process reference 2.	0 ... 10000

Index	Name/Selection	Description	FbEq
41.05	REFERENCE STEP 1	<p>Sets a percentage that is added to the process reference when one auxiliary (direct-on-line) motor or follower drive is running.</p> <p><i>Example:</i> The drive operates three parallel pumps that pump water into a pipe. The pressure in the pipe is controlled. The constant pressure reference is set by parameter 41.03. During low water consumption, only the speed-regulated pump is run. When water consumption increases, constant-speed (direct-on-line) pumps are started: first one pump, and if the demand grows further, also the other pump. As water flow increases, the pressure loss between the beginning (point of measurement) and the end of the pipe increases. By setting suitable reference steps the process reference is increased along the increasing pumping capacity. The reference steps compensate the growing pressure loss and prevent the pressure fall at the end of the pipe.</p>	
	0.0 ... 100.0%	Reference step 1.	0 ... 10000
41.06	REFERENCE STEP 2	<p>Sets a percentage that is added to the process reference when two auxiliary (direct-on-line) motors or follower drives are running. See parameter 41.05.</p>	
	0.0 ... 100.0%	Reference step 2.	0 ... 10000
41.07	REFERENCE STEP 3	<p>Sets a percentage that is added to the process reference when three auxiliary (direct-on-line) motors or follower drives are running. See parameter 41.05.</p>	
	0.0 ... 100.0%	Reference step 3.	0 ... 10000
41.08	REFERENCE STEP 4	<p>Sets a percentage that is added to the process reference when four auxiliary (direct-on-line) motors or follower drives are running. See parameter 41.05.</p>	
	0.0 ... 100.0%	Reference step 4.	0 ... 10000
41.09	REFERENCE STEP 5	<p>Sets a percentage that is added to the process reference when five follower drives are running. See parameter 41.05.</p>	
	0.0 ... 100.0%	Reference step 5.	0 ... 10000
41.10	REFERENCE STEP 6	<p>Sets a percentage that is added to the process reference when six follower drives are running. See parameter 41.05.</p>	
	0.0 ... 100.0%	Reference step 6.	0 ... 10000
41.11	REFERENCE STEP 7	<p>Sets a percentage that is added to the process reference when seven follower drives are running. See parameter 41.05.</p>	
	0.0 ... 100.0%	Reference step 7.	0 ... 10000

Index	Name/Selection	Description	FbEq
41.12	START FREQ 1	<p>Defines the start frequency for auxiliary motor or follower drive 1.</p> <p>When the output frequency of the drive exceeds this value + 1 Hz and no auxiliary motors are running, the start delay counter (see parameters 41.26 and/or 42.02) is started. If the frequency is still at the same level or higher when the delay elapses, the first auxiliary pump or follower starts.</p> <p>If the PFC TRAD macro is selected, the output frequency of the drive is decreased by Start frequency 1 - Low frequency 1 (41.12-41.19) after the auxiliary pump starts. With the Multipump macro, the freshly-started drive becomes the master; the previously-started drive becomes a follower and starts to run at the speed selected by parameters 60.02 and 60.03.</p> <p>The following diagram shows the mutual order of some common frequencies in a pump application.</p> <p><i>Frequency</i></p> <p>↑</p> <p>Maximum frequency (20.02)</p> <p>Start frequency 1 (41.12) (Start frequency of auxiliary motor or follower 1)</p> <p>Low frequency 1 (41.19) (Stop frequency of auxiliary motor or follower 1)</p> <p>Sleep level (43.03)</p> <p>PI controller minimum frequency (20.07)</p> <p>0 Hz</p> <p>(Negative frequencies only used by the Anti-jam function (46.05))</p> <p>↓</p> <p>Minimum frequency (20.01)</p>	
	0.0 ... 120.0 Hz	Start frequency 1.	0 ... 120
41.13	START FREQ 2	Defines the start frequency for auxiliary motor or follower drive 2. See parameter 41.12 .	
	0.0 ... 120.0 Hz	Start frequency 2.	0 ... 120
41.14	START FREQ 3	Defines the start frequency for auxiliary motor or follower drive 3. See parameter 41.12 .	
	0.0 ... 120.0 Hz	Start frequency 3.	0 ... 120
41.15	START FREQ 4	Defines the start frequency for auxiliary motor or follower drive 4. See parameter 41.12 .	
	0.0 ... 120.0 Hz	Start frequency 4.	0 ... 120
41.16	START FREQ 5	Defines the start frequency for follower drive 5. See parameter 41.12 .	
	0.0 ... 120.0 Hz	Start frequency 5.	0 ... 120
41.17	START FREQ 6	Defines the start frequency for follower drive 6. See parameter 41.12 .	
	0.0 ... 120.0 Hz	Start frequency 6.	0 ... 120
41.18	START FREQ 7	Defines the start frequency for follower drive 7. See parameter 41.12 .	
	0.0 ... 120.0 Hz	Start frequency 7.	0 ... 120

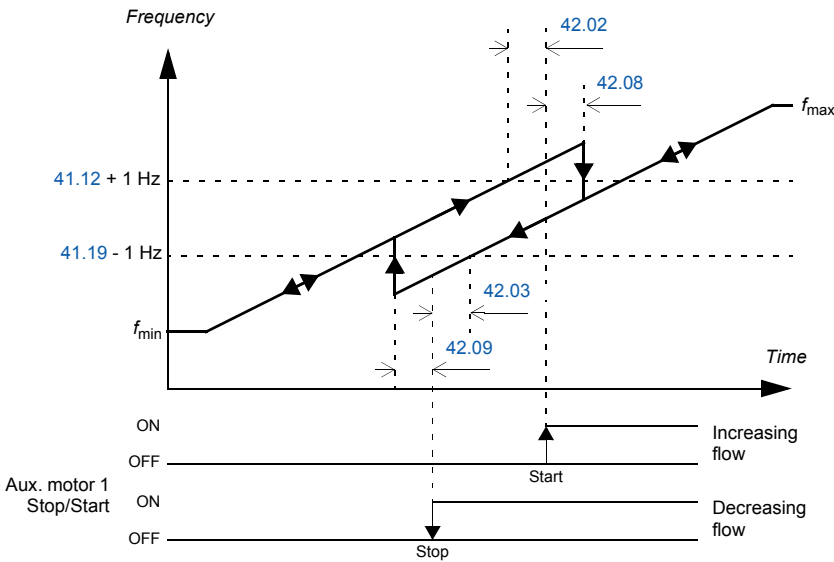

Index	Name/Selection	Description	FbEq
41.19	LOW FREQ 1	Defines the low (stop) frequency for auxiliary motor or follower drive 1. When the output frequency of the drive falls below this value - 1 Hz and one auxiliary motor is running, the stop delay counter (see parameters 41.27 and/or 42.03) is started. If the frequency is still at the same level or lower when the delay elapses, the first auxiliary pump or follower stops. If the PFC TRAD macro is selected, the output frequency of the drive is increased by Start frequency 1 - Low frequency 1 (41.12-41.19) after the auxiliary pump stops. With the Multipump macro, the most recently started drive is stopped; the previously-started drive becomes the master.	
	0.0 ... 120.0 Hz	Low frequency 1.	0 ... 120
41.20	LOW FREQ 2	Defines the low (stop) frequency for auxiliary motor or follower drive 2. See parameter 41.19.	
	0.0 ... 120.0 Hz	Low frequency 2.	0 ... 120
41.21	LOW FREQ 3	Defines the low (stop) frequency for auxiliary motor or follower drive 3. See parameter 41.19.	
	0.0 ... 120.0 Hz	Low frequency 3.	0 ... 120
41.22	LOW FREQ 4	Defines the low (stop) frequency for auxiliary motor or follower drive 4. See parameter 41.19.	
	0.0 ... 120.0 Hz	Low frequency 4.	0 ... 120
41.23	LOW FREQ 5	Defines the low (stop) frequency for follower drive 5. See parameter 41.19.	
	0.0 ... 120.0 Hz	Low frequency 5.	0 ... 120
41.24	LOW FREQ 6	Defines the low (stop) frequency for follower drive 6. See parameter 41.19.	
	0.0 ... 120.0 Hz	Low frequency 6.	0 ... 120
41.25	LOW FREQ 7	Defines the low (stop) frequency for follower drive 6. See parameter 41.19.	
	0.0 ... 120.0 Hz	Low frequency 7.	0 ... 120
41.26	FOLLOWER START DL	In a multipump application, defines a start delay for follower drives. See parameter 41.12.	
	0.0 ... 3600.0 s	Follower start delay.	0 ... 3600
41.27	FOLLOWER STOP DLY	In a multipump application, defines a stop delay for follower drives. See parameter 41.19.	
	0.0 ... 3600.0 s	Follower stop delay.	0 ... 3600
42 PFC-CONTROL 2		Auxiliary motor set-up (start/stop delays, autochange). Only visible when the PFC TRAD macro is selected.	
42.01	NBR OF AUX MOTORS	Defines the number of auxiliary motors, i.e. motors in excess of 1. Note: After changing the value of this parameter, check the settings of the relay outputs in parameter group 14. Note: Without additional hardware, the drive supports the use of up to two auxiliary motors*. An optional digital input/output extension module (RDIO) is required for the use of three to four auxiliary motors. See parameter group 98. *Three auxiliary motors can be used without additional hardware if the Interlocks and Autochange functions are not used (see below).  WARNING! Use of the Autochange function also requires the use of the Interlocks function.	
	ZERO	No auxiliary motors used (a one-pump/fan station).	1
	ONE	One auxiliary motor used (two-pump/fan station).	2
	TWO	Two auxiliary motors used (three-pump/fan station).	3
	THREE	Three auxiliary motors used (four-pump/fan station).	4

Index	Name/Selection	Description	FbEq
	FOUR	Four auxiliary motors used (five-pump/fan station).	5
42.02	AUX MOT START DLY	Start delay for auxiliary motors. 	
	0.0 ... 3600.0 s	Auxiliary motor start delay.	0 ... 3600
42.03	AUX MOT STOP DLY	Stop delay for auxiliary motors. See parameter 42.02.	
	0.0 ... 3600.0 s	Auxiliary motor stop delay.	0 ... 3600
42.04	INTERLOCKS	<p>Defines the use of the Interlocks function.</p> <p> WARNING! Use of the Autochange function (parameter 42.06) also requires the use of the Interlocks function.</p> <p>The Interlocks function is used with multimotor applications where one motor at a time is connected to the output of the drive. The remaining motors are powered from the supply line and started and stopped by the relay outputs of the drive.</p> <p>A contact of the manual on/off switch (or protective device, such as a thermal relay, etc.) of each motor is wired to the interlock circuit. The logic will detect if a motor is unavailable and start the next available motor instead.</p> <p>If the interlock circuit of the speed-regulated motor is switched off, the motor is stopped and all relay outputs are de-energised. Then the drive will restart. The next available motor in the Autochange sequence will be started as regulated.</p> <p>If the interlock circuit of a direct-on-line motor is switched off, the drive will not try to start the motor until the interlock circuit is switched on again. The other motors will operate normally.</p> <p>The selection SET1 uses predominantly the standard inputs and outputs of the drive, while SET2 uses those of optional digital I/O extension modules (type RDIO).</p>	

Index	Name/Selection	Description	FbEq																																																																		
	OFF	<p>The Interlocks function is not in use; digital inputs DI2, DI3 and DI4 are available for other purposes. The speed-regulated motor is directly connected to the drive; auxiliary (direct-on-line) motors are started and stopped whenever necessary. The auxiliary motors can be controlled primarily through the standard relay outputs or optional digital I/O extension modules (type RDIO). The selection between the desired relay outputs is made by the parameters in Group 14.</p> <p>Depending on the number of auxiliary motors (parameter 42.01), the standard relay outputs are used as follows:</p> <table border="1"> <thead> <tr> <th colspan="3">Usage of standard relay outputs</th> </tr> <tr> <th>42.01</th> <th>Output</th> <th>Assignment/Note</th> </tr> </thead> <tbody> <tr> <td>0</td> <td>–</td> <td>N/A</td> </tr> <tr> <td>1</td> <td>RO1</td> <td>Controls the start/stop contactor of auxiliary motor no. 1.</td> </tr> <tr> <td rowspan="2">2</td> <td>RO1</td> <td>Controls the start/stop contactor of auxiliary motor no. 1.</td> </tr> <tr> <td>RO2</td> <td>Controls the start/stop contactor of auxiliary motor no. 2.</td> </tr> <tr> <td rowspan="3">3</td> <td>RO1</td> <td>Controls the start/stop contactor of auxiliary motor no. 1.</td> </tr> <tr> <td>RO2</td> <td>Controls the start/stop contactor of auxiliary motor no. 2.</td> </tr> <tr> <td>RO3</td> <td>Controls the start/stop contactor of auxiliary motor no. 3.</td> </tr> <tr> <td rowspan="4">4</td> <td>RO1</td> <td>Controls the start/stop contactor of auxiliary motor no. 1.</td> </tr> <tr> <td>RO2</td> <td>Controls the start/stop contactor of auxiliary motor no. 2.</td> </tr> <tr> <td>RO3</td> <td>Controls the start/stop contactor of auxiliary motor no. 3.</td> </tr> <tr> <td>RDIO1 RO1</td> <td>Relay output RO1 of the first RDIO module controls the start/stop contactor of auxiliary motor no. 4. Note: The module must be enabled by parameter 98.03.</td> </tr> </tbody> </table> <p>Alternatively, optional digital I/O extension modules can be used:</p> <table border="1"> <thead> <tr> <th colspan="3">Usage of relay outputs of digital I/O extension modules</th> </tr> <tr> <th>42.01</th> <th>Output</th> <th>Assignment/Note</th> </tr> </thead> <tbody> <tr> <td>0</td> <td>–</td> <td>N/A</td> </tr> <tr> <td>1</td> <td>RDIO1 RO1</td> <td>Relay output RO1 of the first RDIO module controls the start/stop contactor of auxiliary motor no. 1.</td> </tr> <tr> <td rowspan="2">2</td> <td>RDIO1 RO1</td> <td>Relay output RO1 of the first RDIO module controls the start/stop contactor of auxiliary motor no. 1.</td> </tr> <tr> <td>RDIO1 RO2</td> <td>Relay output RO2 of the first RDIO module controls the start/stop contactor of auxiliary motor no. 2.</td> </tr> <tr> <td rowspan="3">3</td> <td>RDIO1 RO1</td> <td>Relay output RO1 of the first RDIO module controls the start/stop contactor of auxiliary motor no. 1.</td> </tr> <tr> <td>RDIO1 RO2</td> <td>Relay output RO2 of the first RDIO module controls the start/stop contactor of auxiliary motor no. 2.</td> </tr> <tr> <td>RDIO2 RO1</td> <td>Relay output RO1 of the second RDIO module controls the start/stop contactor of auxiliary motor no. 3.</td> </tr> <tr> <td rowspan="4">4</td> <td>RDIO1 RO1</td> <td>Relay output RO1 of the first RDIO module controls the start/stop contactor of auxiliary motor no. 1.</td> </tr> <tr> <td>RDIO1 RO2</td> <td>Relay output RO2 of the first RDIO module controls the start/stop contactor of auxiliary motor no. 2.</td> </tr> <tr> <td>RDIO2 RO1</td> <td>Relay output RO1 of the second RDIO module controls the start/stop contactor of auxiliary motor no. 3.</td> </tr> <tr> <td>RDIO2 RO2</td> <td>Relay output RO2 of the second RDIO module controls the start/stop contactor of auxiliary motor no. 4.</td> </tr> </tbody> </table> <p>Note: The RDIO modules must be enabled by parameters 98.03 and 98.04.</p>	Usage of standard relay outputs			42.01	Output	Assignment/Note	0	–	N/A	1	RO1	Controls the start/stop contactor of auxiliary motor no. 1.	2	RO1	Controls the start/stop contactor of auxiliary motor no. 1.	RO2	Controls the start/stop contactor of auxiliary motor no. 2.	3	RO1	Controls the start/stop contactor of auxiliary motor no. 1.	RO2	Controls the start/stop contactor of auxiliary motor no. 2.	RO3	Controls the start/stop contactor of auxiliary motor no. 3.	4	RO1	Controls the start/stop contactor of auxiliary motor no. 1.	RO2	Controls the start/stop contactor of auxiliary motor no. 2.	RO3	Controls the start/stop contactor of auxiliary motor no. 3.	RDIO1 RO1	Relay output RO1 of the first RDIO module controls the start/stop contactor of auxiliary motor no. 4. Note: The module must be enabled by parameter 98.03.	Usage of relay outputs of digital I/O extension modules			42.01	Output	Assignment/Note	0	–	N/A	1	RDIO1 RO1	Relay output RO1 of the first RDIO module controls the start/stop contactor of auxiliary motor no. 1.	2	RDIO1 RO1	Relay output RO1 of the first RDIO module controls the start/stop contactor of auxiliary motor no. 1.	RDIO1 RO2	Relay output RO2 of the first RDIO module controls the start/stop contactor of auxiliary motor no. 2.	3	RDIO1 RO1	Relay output RO1 of the first RDIO module controls the start/stop contactor of auxiliary motor no. 1.	RDIO1 RO2	Relay output RO2 of the first RDIO module controls the start/stop contactor of auxiliary motor no. 2.	RDIO2 RO1	Relay output RO1 of the second RDIO module controls the start/stop contactor of auxiliary motor no. 3.	4	RDIO1 RO1	Relay output RO1 of the first RDIO module controls the start/stop contactor of auxiliary motor no. 1.	RDIO1 RO2	Relay output RO2 of the first RDIO module controls the start/stop contactor of auxiliary motor no. 2.	RDIO2 RO1	Relay output RO1 of the second RDIO module controls the start/stop contactor of auxiliary motor no. 3.	RDIO2 RO2	Relay output RO2 of the second RDIO module controls the start/stop contactor of auxiliary motor no. 4.	1
Usage of standard relay outputs																																																																					
42.01	Output	Assignment/Note																																																																			
0	–	N/A																																																																			
1	RO1	Controls the start/stop contactor of auxiliary motor no. 1.																																																																			
2	RO1	Controls the start/stop contactor of auxiliary motor no. 1.																																																																			
	RO2	Controls the start/stop contactor of auxiliary motor no. 2.																																																																			
3	RO1	Controls the start/stop contactor of auxiliary motor no. 1.																																																																			
	RO2	Controls the start/stop contactor of auxiliary motor no. 2.																																																																			
	RO3	Controls the start/stop contactor of auxiliary motor no. 3.																																																																			
4	RO1	Controls the start/stop contactor of auxiliary motor no. 1.																																																																			
	RO2	Controls the start/stop contactor of auxiliary motor no. 2.																																																																			
	RO3	Controls the start/stop contactor of auxiliary motor no. 3.																																																																			
	RDIO1 RO1	Relay output RO1 of the first RDIO module controls the start/stop contactor of auxiliary motor no. 4. Note: The module must be enabled by parameter 98.03.																																																																			
Usage of relay outputs of digital I/O extension modules																																																																					
42.01	Output	Assignment/Note																																																																			
0	–	N/A																																																																			
1	RDIO1 RO1	Relay output RO1 of the first RDIO module controls the start/stop contactor of auxiliary motor no. 1.																																																																			
2	RDIO1 RO1	Relay output RO1 of the first RDIO module controls the start/stop contactor of auxiliary motor no. 1.																																																																			
	RDIO1 RO2	Relay output RO2 of the first RDIO module controls the start/stop contactor of auxiliary motor no. 2.																																																																			
3	RDIO1 RO1	Relay output RO1 of the first RDIO module controls the start/stop contactor of auxiliary motor no. 1.																																																																			
	RDIO1 RO2	Relay output RO2 of the first RDIO module controls the start/stop contactor of auxiliary motor no. 2.																																																																			
	RDIO2 RO1	Relay output RO1 of the second RDIO module controls the start/stop contactor of auxiliary motor no. 3.																																																																			
4	RDIO1 RO1	Relay output RO1 of the first RDIO module controls the start/stop contactor of auxiliary motor no. 1.																																																																			
	RDIO1 RO2	Relay output RO2 of the first RDIO module controls the start/stop contactor of auxiliary motor no. 2.																																																																			
	RDIO2 RO1	Relay output RO1 of the second RDIO module controls the start/stop contactor of auxiliary motor no. 3.																																																																			
	RDIO2 RO2	Relay output RO2 of the second RDIO module controls the start/stop contactor of auxiliary motor no. 4.																																																																			

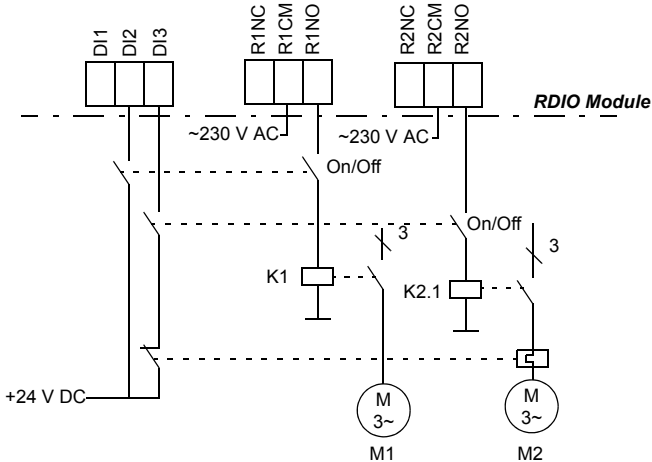
Index	Name/Selection	Description	FbEq
SET 1		The Interlocks function is in use. Depending on the number of auxiliary motors, the relay outputs and digital inputs are used as follows:	2
42.01	Usage of relay outputs and digital inputs		
	I/O	Assignment/Note	
0	DI2 RO1	Monitors the status of motor no. 1. Controls the start/stop contactor of motor no. 1.	
1	DI2/3 RO1/2	Monitor the status of motors no. 1 and 2 respectively. Control the start/stop contactors of motors no. 1 and 2 respectively.	
2	DI2/3/4 RO1/2/3	Monitor the status of motors no. 1, 2 and 3 respectively. Control the start/stop contactors of motors 1, 2 and 3 respectively.	
3	DI2/3/4 RDIO1 DI1 (DI7) RO1/2/3 RDIO1 RO1	Monitor the status of motors no. 1, 2 and 3 respectively. Digital input DI1 of the first RDIO module (DI7) monitors the status of motor 4. Control the start/stop contactors of motors 1, 2 and 3 respectively. Relay output RO1 of the first RDIO module controls the start/stop contactor of motor no. 4.	
4	DI2/3/4 RDIO1 DI1/2 (DI7/DI8) RO1/2/3 RDIO1 RO1/2	Monitor the status of motors no. 1, 2 and 3 respectively. Digital inputs DI1 and DI2 of the first RDIO module (DI7 and DI8) monitor the status of motors 4 and 5 respectively. Control the start/stop contactors of motors 1, 2 and 3 respectively. Relay outputs RO1 and RO2 of the first RDIO module control the start/stop contactors of motors no. 4 and 5 respectively.	
Below is an example of two motors connected to the drive with SET1 selected.			
Note: Any RDIO modules present must be enabled by parameters 98.03 and 98.04 .			

Index	Name/Selection	Description	FbEq																																			
SET 2		<p>The Interlocks function is in use. Depending on the number of auxiliary motors, the relay outputs and digital inputs are used as follows:</p> <table border="1" data-bbox="440 371 1281 1131"> <thead> <tr> <th colspan="3" data-bbox="440 371 1281 405">Usage of relay outputs and digital inputs</th> </tr> <tr> <th data-bbox="440 405 523 427">42.01</th> <th data-bbox="523 405 651 427">I/O</th> <th data-bbox="651 405 1281 427">Assignment/Note</th> </tr> </thead> <tbody> <tr> <td data-bbox="440 427 523 539" rowspan="2">0</td> <td data-bbox="523 427 651 483">RDIO1 DI2 (DI8)</td> <td data-bbox="651 427 1281 483">Digital input DI2 of the first RDIO module (DI8) monitors the status of motor no. 1.</td> </tr> <tr> <td data-bbox="523 483 651 539">RDIO1 RO1</td> <td data-bbox="651 483 1281 539">Relay output RO1 of the first RDIO module controls the start/stop contactor of motor no. 1.</td> </tr> <tr> <td data-bbox="440 539 523 651" rowspan="2">1</td> <td data-bbox="523 539 651 595">RDIO1 DI2/3</td> <td data-bbox="651 539 1281 595">Digital inputs DI2 and DI3 of the first RDIO module (DI8 and DI9) monitor the status of motors no. 1 and 2 respectively.</td> </tr> <tr> <td data-bbox="523 595 651 651">RDIO1 RO1/2</td> <td data-bbox="651 595 1281 651">Relay outputs RO1 and RO2 of the first RDIO module control the start/stop contactors of motors no. 1 and 2 respectively.</td> </tr> <tr> <td data-bbox="440 651 523 875" rowspan="3">2</td> <td data-bbox="523 651 651 707">RDIO1 DI2/3</td> <td data-bbox="651 651 1281 707">Digital inputs DI2 and DI3 of the first RDIO module (DI8 and DI9) monitor the status of motors no. 1 and 2 respectively.</td> </tr> <tr> <td data-bbox="523 707 651 763">RDIO2 DI1</td> <td data-bbox="651 707 1281 763">Digital input DI1 of the second RDIO module (DI10) monitors the status of motor 3.</td> </tr> <tr> <td data-bbox="523 763 651 819">RDIO2 RO1</td> <td data-bbox="651 763 1281 819">Relay output RO1 of the second RDIO module controls the start/stop contactor of motor 3.</td> </tr> <tr> <td data-bbox="440 875 523 1099" rowspan="4">3</td> <td data-bbox="523 875 651 931">RDIO1 DI2/3</td> <td data-bbox="651 875 1281 931">Digital inputs DI2 and DI3 of the first RDIO module (DI8 and DI9) monitor the status of motors no. 1 and 2 respectively.</td> </tr> <tr> <td data-bbox="523 931 651 987">RDIO2 DI1/2</td> <td data-bbox="651 931 1281 987">Digital inputs DI1 and DI2 of the second RDIO module (DI10 and DI11) monitor the status of motors 3 and 4 respectively.</td> </tr> <tr> <td data-bbox="523 987 651 1043">RDIO1 RO1/2</td> <td data-bbox="651 987 1281 1043">Relay outputs RO1 and RO2 of the first RDIO module control the start/stop contactors of motors 1 and 2 respectively.</td> </tr> <tr> <td data-bbox="523 1043 651 1099">RDIO2 RO1/2</td> <td data-bbox="651 1043 1281 1099">Relay outputs RO1 and RO2 of the second RDIO module control the start/stop contactors of motors 3 and 4 respectively.</td> </tr> <tr> <td data-bbox="440 1099 523 1131">4</td> <td data-bbox="523 1099 1281 1131">Not applicable.</td> <td data-bbox="651 1099 1281 1131"></td> </tr> </tbody> </table> <p data-bbox="440 1171 1281 1205">Below is an example of two motors connected to the drive with SET2 selected.</p>  <p data-bbox="440 1709 1281 1742">Note: The RDIO modules must be enabled by parameters 98.03 and 98.04.</p>	Usage of relay outputs and digital inputs			42.01	I/O	Assignment/Note	0	RDIO1 DI2 (DI8)	Digital input DI2 of the first RDIO module (DI8) monitors the status of motor no. 1.	RDIO1 RO1	Relay output RO1 of the first RDIO module controls the start/stop contactor of motor no. 1.	1	RDIO1 DI2/3	Digital inputs DI2 and DI3 of the first RDIO module (DI8 and DI9) monitor the status of motors no. 1 and 2 respectively.	RDIO1 RO1/2	Relay outputs RO1 and RO2 of the first RDIO module control the start/stop contactors of motors no. 1 and 2 respectively.	2	RDIO1 DI2/3	Digital inputs DI2 and DI3 of the first RDIO module (DI8 and DI9) monitor the status of motors no. 1 and 2 respectively.	RDIO2 DI1	Digital input DI1 of the second RDIO module (DI10) monitors the status of motor 3.	RDIO2 RO1	Relay output RO1 of the second RDIO module controls the start/stop contactor of motor 3.	3	RDIO1 DI2/3	Digital inputs DI2 and DI3 of the first RDIO module (DI8 and DI9) monitor the status of motors no. 1 and 2 respectively.	RDIO2 DI1/2	Digital inputs DI1 and DI2 of the second RDIO module (DI10 and DI11) monitor the status of motors 3 and 4 respectively.	RDIO1 RO1/2	Relay outputs RO1 and RO2 of the first RDIO module control the start/stop contactors of motors 1 and 2 respectively.	RDIO2 RO1/2	Relay outputs RO1 and RO2 of the second RDIO module control the start/stop contactors of motors 3 and 4 respectively.	4	Not applicable.		3
Usage of relay outputs and digital inputs																																						
42.01	I/O	Assignment/Note																																				
0	RDIO1 DI2 (DI8)	Digital input DI2 of the first RDIO module (DI8) monitors the status of motor no. 1.																																				
	RDIO1 RO1	Relay output RO1 of the first RDIO module controls the start/stop contactor of motor no. 1.																																				
1	RDIO1 DI2/3	Digital inputs DI2 and DI3 of the first RDIO module (DI8 and DI9) monitor the status of motors no. 1 and 2 respectively.																																				
	RDIO1 RO1/2	Relay outputs RO1 and RO2 of the first RDIO module control the start/stop contactors of motors no. 1 and 2 respectively.																																				
2	RDIO1 DI2/3	Digital inputs DI2 and DI3 of the first RDIO module (DI8 and DI9) monitor the status of motors no. 1 and 2 respectively.																																				
	RDIO2 DI1	Digital input DI1 of the second RDIO module (DI10) monitors the status of motor 3.																																				
	RDIO2 RO1	Relay output RO1 of the second RDIO module controls the start/stop contactor of motor 3.																																				
3	RDIO1 DI2/3	Digital inputs DI2 and DI3 of the first RDIO module (DI8 and DI9) monitor the status of motors no. 1 and 2 respectively.																																				
	RDIO2 DI1/2	Digital inputs DI1 and DI2 of the second RDIO module (DI10 and DI11) monitor the status of motors 3 and 4 respectively.																																				
	RDIO1 RO1/2	Relay outputs RO1 and RO2 of the first RDIO module control the start/stop contactors of motors 1 and 2 respectively.																																				
	RDIO2 RO1/2	Relay outputs RO1 and RO2 of the second RDIO module control the start/stop contactors of motors 3 and 4 respectively.																																				
4	Not applicable.																																					
42.06	AUTOCHANGE INTERV	Switches on the Autochange function, and specifies the Autochange interval. See parameter 42.07 .																																				

Index	Name/Selection	Description	FbEq
	0 h 00 min ... 336 h 00 min (14 days)	<p>Autochange interval. 0 h 00 min = Autochange function disabled.</p> <p>Note: The counter runs only when the start signal of the drive is on.</p> <p> WARNING! If the Autochange function is used, also the Interlocks function must be used, and parameter 21.03 set to COAST. In an Autochange system, there is a contactor between the drive output and the speed-controlled motor. The contactor will be damaged if opened without first interrupting the power stage switching of the drive. The switching is interrupted when the interlock is switched off and the selected stop mode is COAST.</p>	0 ... 20160 (min)
42.07	AUTOCHANGE LEVEL	<p>Output frequency limit for the Autochange function.</p> <p>The motor starting sequence is changed when the Autochange interval has elapsed and the output frequency is below this limit. Autochanging is indicated by a warning on the control panel display.</p> <p>Note: The value of this parameter must be within allowed range (eg. between minimum and maximum limits). Otherwise no Autochanging is possible.</p> <p>Note: When the drive power is switched off, the values of the starting sequence counter and the Autochange interval counter are stored. The counters will continue using these values after the power is switched on again.</p> <p><i>Example:</i> There are three motors in a system (parameter 42.01 is set to 2). Autochange level is set to 40 Hz.</p> <p>An Autochange occurs when the output frequency is below 40 Hz, and Autochange interval since the previous Autochange has elapsed. Upon an Autochange,</p> <ol style="list-style-type: none"> 1) All motors are stopped 2) The starting sequence is incremented (from 1-2-3 to 2-3-1, etc.) 3) The contactor that controls the speed-regulated motor is closed 4) The delay set by parameter 42.10 is waited 5) The speed-regulated motor is energised and normal PFC operation starts. <p>If the Autochange level is 0 Hz and the interval has elapsed, Autochange will occur during a stop, eg. when the Sleep function is active.</p>	
	0.0 ... 100.0 Hz	Autochange level.	0 ... 10000
42.08	FREQ TIME ON DLY	See diagram at parameter 42.02.	
	0.0 ... 3600.0 s		0 ... 3600
42.09	FREQ TIME OFF DLY	See diagram at parameter 42.02.	
	0.0 ... 3600.0 s		0 ... 3600
42.10	PFC START DELAY	<p>Start delay for the speed-regulated motor. Does not affect the starting of the direct-on-line motors. See parameter 42.07.</p> <p> WARNING! There must always be a delay set if the motors are equipped with star-delta starters. The delay must be set longer than the time setting of the starter. After the motor is switched on by the relay output of the drive, there must be enough time for the star-delta starter to first switch to star and then back to delta before the motor is connected to the drive.</p>	
	0 ... 10000 ms	PFC start delay.	0 ... 10000

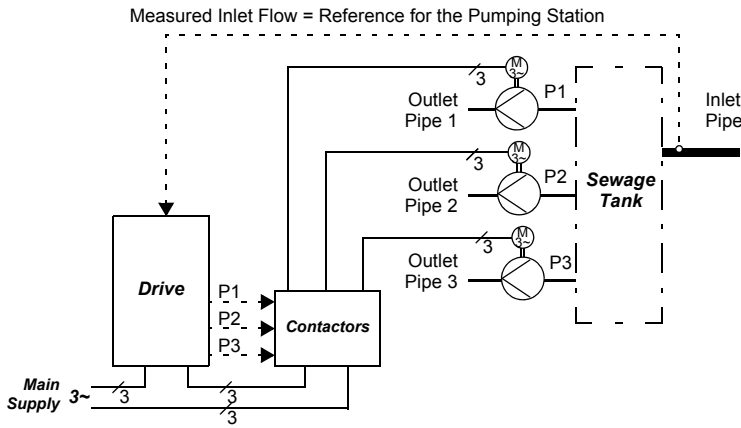
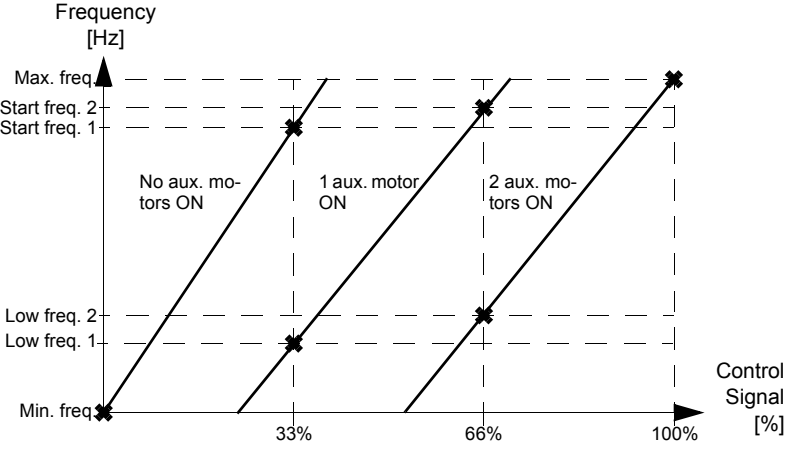
Index	Name/Selection	Description	FbEq
42.11	REGUL BYPASS CTRL	<p>Selects whether the process PI controller is bypassed.</p> <p>This parameter can be used in applications with a low number of sensors and low accuracy requirements.</p> <p><i>Example:</i> The capacity of the pumping station (outlet flow) follows the measured inlet flow.</p>  <p>In the diagram below, the slopes of the lines describe the relation between the control signal (selected by parameter 40.04) and the frequency of the controlled motor (i.e. drive output frequency) in a three-motor system. At full control signal level, all pumps are operating at maximum frequency.</p> 	
	NO	Process PI controller is in use.	0
	YES	Process PI controller is bypassed. The signal selected by parameter 40.04 is used as the frequency reference. The automatic start/stop of direct-on-line motors is related to this actual value signal instead of the output of the PI controller.	65535
43 SLEEP FUNCTION		Sleep function set-up.	
43.01	SLEEP SELECTION	Controls the Sleep function.	
	OFF	The Sleep function is disabled.	1
	INTERNAL	The Sleep function is activated and deactivated as defined by parameters 43.02 to 43.08.	2

Index	Name/Selection	Description	FbEq
	SLEEP1 PTR	<p>The Sleep function is controlled by the signal defined by parameter 43.09. If the signal is OFF, the Sleep function is activated and deactivated as defined by parameters 43.02 to 43.08.</p> <p>When the signal switches ON, the reference is set to 0%. The drive will enter Sleep mode as soon as the output frequency falls below the value of parameter 43.03, and will not wake up as long as the signal stays ON.</p> <p>After the signal switches OFF, the drive continues to operate according to the Sleep function set-up parameters.</p> <p>Note: With this selection, parameter 43.07 has no effect.</p>	3
	SLEEP2 PTR	<p>The Sleep function is activated by the signal defined by parameter 43.10.</p> <p>When the signal switches ON, the drive immediately enters Sleep mode if no auxiliary motors are running and the wake-up level (parameter 43.05) has not been exceeded. (The sleep level is not observed.)</p> <p>After the wake-up level is reached, the drive will wake up regardless of the state of the signal.</p>	4
43.02	SLEEP DELAY	<p>Sets the Sleep delay for the Sleep function.</p> <p>If the output frequency of the drive stays below the value set by parameter 43.03 longer than the Sleep delay, the drive stops, and the control panel displays the warning "SLEEP MODE". See the diagram at parameter 43.03.</p>	
	0.0 ... 3600.0 s	Sleep delay.	0 ... 3600

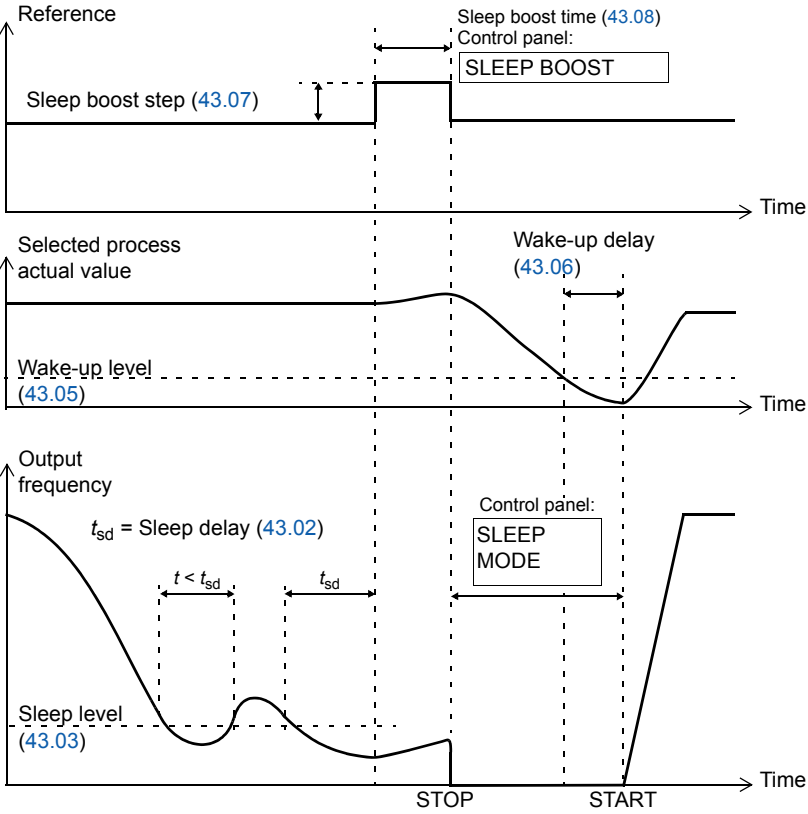
Index	Name/Selection	Description	FbEq									
43.03	SLEEP LEVEL	<p>Sets the frequency limit for the Sleep function. When the output frequency of the drive drops below this limit, the sleep delay counter is started. When the output frequency exceeds this limit, the sleep delay counter is reset.</p>  <p>Note: The Sleep level setting should be greater than the minimum frequency setting (parameter 20.01). Otherwise the output frequency of the drive will never fall below the Sleep level.</p>										
	0.0 ... 120.0 Hz	<p>Sleep level in Hz. Setting the parameter to 0 disables the Sleep function.</p>	0 ... 120									
43.04	WAKE UP SEL MODE	<p>Defines the wake-up level.</p>										
	WAKE UP 1	<p>The wake-up level is given as percent of the used process reference. The drive enters the wake-up sequence when the currently selected process actual value falls below the wake-up level.</p> <p><i>Example:</i> The PFC application program follows a process reference set by parameter 41.03. The table below shows the wake-up level with two process reference settings, and two wake-up level settings.</p> <table border="1" data-bbox="517 1659 1201 1783"> <thead> <tr> <th>Value of 41.03</th> <th>Value of 43.05</th> <th>Wake-up level</th> </tr> </thead> <tbody> <tr> <td>100%</td> <td>50%</td> <td>50% of 100% = 50%</td> </tr> <tr> <td>80%</td> <td>40%</td> <td>40% of 80% = 32%</td> </tr> </tbody> </table>	Value of 41.03	Value of 43.05	Wake-up level	100%	50%	50% of 100% = 50%	80%	40%	40% of 80% = 32%	1
Value of 41.03	Value of 43.05	Wake-up level										
100%	50%	50% of 100% = 50%										
80%	40%	40% of 80% = 32%										

Index	Name/Selection	Description	FbEq
	WAKE UP 2	<p>The wake-up level is related to the used process reference so that the range of parameter 43.05 inversely corresponds to the range between the process reference in use and 100% level.</p> <p>The relation is defined by the following equation:</p> $\text{Wake-up level [\%]} = 100 - \frac{100\% - \text{REF}[\%]}{100} \times (\text{Value of par. 43.05} [\%])$ <p>where REF = Process reference used</p> <p>The drive enters the wake-up sequence when the selected process actual value exceeds the wake-up level. Example: At 50% process reference, a wake-up level of 90% is obtained when parameter 43.05 is set to 20.0%:</p> $90 = 100 - \frac{100 - 50}{100} \times [\text{par. 43.05}]$ $\Rightarrow 90 = 100 - \frac{[\text{par. 43.05}]}{2} \Rightarrow [\text{par. 43.05}] = 20$ <p>With the same setting, the wake-up level rises to 95% when process reference rises to 75%.</p>	2
	WAKE UP 3	The drive enters the wake-up sequence when the currently selected process actual value falls below the wake-up level (par. 43.05).	3
	WAKE UP 4	The drive enters the wake-up sequence when the currently selected process actual value exceeds the wake-up level (par. 43.05).	4
	[]	Reserved.	
43.05	WAKE UP LEVEL	<p>Sets the process actual value limit for the Sleep function. When the selected process actual value falls below or exceeds (depending on the setting of parameter 43.04) the limit, the wake-up delay counter is started. The value is given as a percentage of an actual signal defined by parameter 43.04.</p> <p>Note: If the PI controller is bypassed (parameter 42.11) or inverted (40.03), the Sleep function is interrupted whenever the process actual value exceeds the wake-up level. In this case, the wake-up level is taken as an absolute percentage value (of 100%).</p>	

Index	Name/Selection	Description	FbEq
	0.0 ... 100.0%	Wake-up level.	0 ... 10000
43.06	WAKE UP DELAY	Sets the wake-up delay for the Sleep function. If the process actual value stays below or above (depending on the setting of parameter 43.04) the wake-up level (parameters 43.04 and 43.05) longer than the wake-up delay, the drive starts. See the diagram at parameter 43.03.	
	0.0 ... 3600.0 s	Wake-up delay.	0 ... 3600
43.07	SLEEP BOOST STEP	When the drive is entering Sleep mode, the reference is increased by this percentage for the time defined by parameter 43.08. (The actual boosted reference is available as actual signal 05.08.) No auxiliary motors are started. If active, Sleep boost is aborted when the drive wakes up. See the diagram at parameter 43.03. Note: This parameter has no effect if parameter 43.01 is set to SLEEP1 PTR.	
	0.0 ... 100.0%	Sleep boost step.	0 ... 10000
43.08	SLEEP BOOST TIME	Sets the boost time for the Sleep boost step (parameter 43.07).	
	0.0 ... 3600.0 s	Sleep boost time.	0 ... 3600
43.09	SLEEP1 SEL PTR	Defines the source or constant for value SLEEP1 PTR of parameter 43.01.	
	-255.255.31 ... +255.255.31 / C.-32768 ... C.32767	Parameter index or a constant value. See Parameter 10.04 for information on the difference.	
43.10	SLEEP2 SEL PTR	Defines the source or constant for value SLEEP2 PTR of parameter 43.01.	
	-255.255.31 ... +255.255.31 / C.-32768 ... C.32767	Parameter index or a constant value. See Parameter 10.04 for information on the difference.	
44 PFC PROTECTION		Set-up of PFC protections.	
44.01	INPUT PROT CTRL	Enables, and selects the mode of, the primary supervision of pump/fan inlet pressure.	
	NOT SEL	Primary inlet pressure supervision not used.	1
	WARNING	Detection of low inlet pressure produces a warning on the control panel display.	2

Index	Name/Selection	Description	FbEq
	PROTECT	<p>Detection of low inlet pressure produces a warning on the control panel display. The output of the PI controller is ramped down (according to par. 44.17) to the forced reference (set by parameter 44.08). The drive will revert to the original reference if the pressure subsequently exceeds the supervision level.</p> <p>The following diagram describes the inlet pressure supervision function.</p>	3
	FAULT	Detection of low inlet pressure trips the drive on a fault.	4
44.02	AI MEASURE INLET	Selects the analogue input for pump/fan inlet pressure supervision.	
	NOT USED	No analogue input selected.	1
	AI1	Pump/fan inlet pressure monitored through selected input.	2
	AI2	Pump/fan inlet pressure monitored through selected input.	3
	AI3	Pump/fan inlet pressure monitored through selected input.	4
	AI5	Pump/fan inlet pressure monitored through selected input.	5
	AI6	Pump/fan inlet pressure monitored through selected input.	6
44.03	AI IN LOW LEVEL	Sets the supervision limit for the primary inlet pressure measurement. If the value of the selected input falls below this limit, the action defined by parameter 44.01 is taken after the delay set by parameter 44.07 expires.	
	0.0 ... 100.0%	The range corresponds to 0 ... 10 V or 0 ... 20 mA on the analogue input. With a bipolar input, the absolute input value is considered.	0 ... 100
44.04	VERY LOW CTRL	Enables, and selects the mode of, the secondary inlet pressure supervision function. The function uses the analogue input selected by parameter 44.02.	
	NOT SEL	Secondary inlet pressure supervision not used.	1
	STOP	Detection of very low inlet pressure stops the drive. The drive will start again if the pressure exceeds the supervision level.	2

Index	Name/Selection	Description	FbEq
	FAULT	Detection of very low inlet pressure trips the drive on a fault.	3
44.05	AI IN VERY LOW	Supervision level for the secondary inlet pressure monitoring function. See parameter 44.04 .	
	0.0 ... 100.0%	Supervision level.	
44.06	DI STATUS INLET	Selects the digital input for connection of a pressure switch at the pump/fan inlet. The "normal" state is 1 (on). If the selected input switches to 0 (off), the action defined by parameter 44.01 is executed after the delay set by parameter 44.07 expires.	
	NOT USED	No digital input selected.	1
	DI1	Pump/fan inlet pressure monitored through selected input.	2
	DI2	Pump/fan inlet pressure monitored through selected input.	3
	DI3	Pump/fan inlet pressure monitored through selected input.	4
	DI4	Pump/fan inlet pressure monitored through selected input.	5
	DI5	Pump/fan inlet pressure monitored through selected input.	6
	DI6	Pump/fan inlet pressure monitored through selected input.	7
	DI7	Pump/fan inlet pressure monitored through selected input.	8
	DI8	Pump/fan inlet pressure monitored through selected input.	9
	DI9	Pump/fan inlet pressure monitored through selected input.	10
	DI10	Pump/fan inlet pressure monitored through selected input.	11
	DI11	Pump/fan inlet pressure monitored through selected input.	12
	DI12	Pump/fan inlet pressure monitored through selected input.	13
44.07	INPUT CTRL DLY	Sets the delay after which the action defined by parameter 44.01 is taken upon detection of low inlet pressure.	
	0 ... 60 s	Delay.	0 ... 60
44.08	INLET FORCED REF	This reference is used after detection of low inlet pressure. See par. 44.01 .  WARNING! Make sure that it is safe to continue operation using this reference.	
	0 ... 100%	Forced reference.	0 ... 100
44.09	OUTPUT PROT CTRL	Enables, and selects the mode of, the primary supervision of pump/fan outlet pressure.	
	NOT SEL	Primary outlet pressure supervision not used.	1
	WARNING	Detection of high outlet pressure produces a warning on the control panel display.	2

Index	Name/Selection	Description	FbEq
	PROTECT	<p>Detection of high outlet pressure produces a warning on the control panel display. The output of the PI controller is ramped down (according to par. 44.17) to the forced reference (set by parameter 44.16). The drive will revert to the original reference if the pressure subsequently falls below the supervision level.</p> <p>The following diagram describes the outlet pressure supervision function.</p>	3
	FAULT	Detection of high outlet pressure trips the drive on a fault.	4
44.10	AI MEASURE OUTLET	Selects the analogue input for pump/fan outlet pressure supervision.	
	NOT USED	No analogue input selected.	1
	AI1	Pump/fan outlet pressure monitored through selected input.	2
	AI2	Pump/fan outlet pressure monitored through selected input.	3
	AI3	Pump/fan outlet pressure monitored through selected input.	4
	AI5	Pump/fan outlet pressure monitored through selected input.	5
	AI6	Pump/fan outlet pressure monitored through selected input.	6
44.11	AI OUT HIGH LEVEL	Sets the supervision limit for the primary outlet pressure measurement. If the value of the selected analogue input exceeds this limit, the action defined by parameter 44.09 is taken after a delay set with parameter 44.15 expires.	
	0.0 ... 100.0%	The range corresponds to 0 ... 10 V or 0 ... 20 mA on the analogue input. With a bipolar input, the absolute input value counts.	0 ... 100
44.12	VERY HIGH CTRL	Enables, and selects the mode of, the secondary outlet pressure supervision function. The function uses the analogue input selected by parameter 44.10.	
	NOT SEL	Secondary outlet pressure monitoring not used.	1

Index	Name/Selection	Description	FbEq
	STOP	Detection of very high outlet pressure stops the drive. The drive will start again if the pressure falls below the supervision level.	2
	FAULT	Detection of very high outlet pressure trips the drive on a fault.	3
44.13	AI OUT VERY HIGH	Supervision level for secondary outlet pressure monitoring function. See parameter 44.09 .	
	0 ... 500%	Supervision level.	0 ... 500
44.14	DI STATUS OUTLET	Selects the digital input for connection of a pressure switch at the pump/fan outlet. The "normal" state is 1 (on). If the selected input switches to 0 (off), the action defined by parameter 44.09 is taken after a delay set by parameter 44.15 expires.	
	NOT USED	No digital input selected.	1
	DI1	Pump/fan outlet pressure monitored through selected input.	2
	DI2	Pump/fan outlet pressure monitored through selected input.	3
	DI3	Pump/fan outlet pressure monitored through selected input.	4
	DI4	Pump/fan outlet pressure monitored through selected input.	5
	DI5	Pump/fan outlet pressure monitored through selected input.	6
	DI6	Pump/fan outlet pressure monitored through selected input.	7
	DI7	Pump/fan outlet pressure monitored through selected input.	8
	DI8	Pump/fan outlet pressure monitored through selected input.	9
	DI9	Pump/fan outlet pressure monitored through selected input.	10
	DI10	Pump/fan outlet pressure monitored through selected input.	11
	DI11	Pump/fan outlet pressure monitored through selected input.	12
	DI12	Pump/fan outlet pressure monitored through selected input.	13
44.15	OUTPUT CTRL DLY	Sets the delay after which the action defined by parameter 44.09 is taken upon detection of high outlet pressure.	
	0 ... 60 s	Delay.	0 ... 60
44.16	OUTLET FORCED REF	This reference is used after detection of high outlet pressure. See par. 44.09 .  WARNING! Make sure that it is safe to continue operation using this reference.	
	0 ... 100%	Forced reference.	0 ... 100
44.17	PI REF DEC TIME	PI controller ramp-down time. See selection PROTECT at parameters 44.01 and 44.09 .	
	0.01 ... 3600.00 s	PI controller ramp-down time.	0 ... 3600
44.18	APPL PROFILE CTRL	Parameters 44.18 to 44.20 provide the Application Profile protection feature, based on long-term monitoring of an internal status signal. If the selected signal exceeds (and remains above) the supervision limit for a longer time than the set delay (par. 44.20), the internal status signal "PROFILE HIGH" is set to 1. The signal can be directed to a relay output (see parameter group 14 RELAY OUTPUTS).	
	CONTROL DEV	Signal 01.26 CONTROL DEVIATION is monitored and compared to parameter 44.19 . Monitoring the deviation between the reference and the actual value gives an indication of the general condition of the pump, piping and valves.	0
	APPL OUTPUT	Signal 01.16 APPL BLOCK OUTPUT is monitored and compared to parameter 44.19 . The signal constantly remaining at 100% may indicate a leak in the output piping.	65535
44.19	PROFILE OUTP LIM	Supervision limit for the Application Profile protection.	

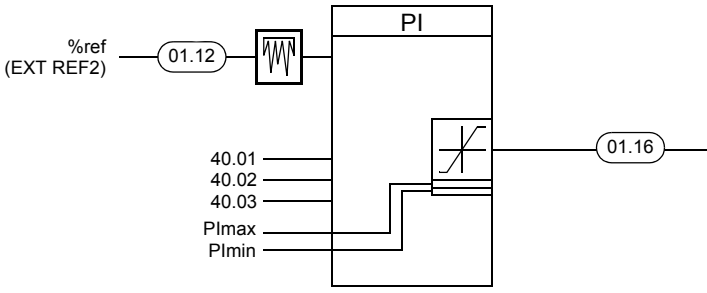
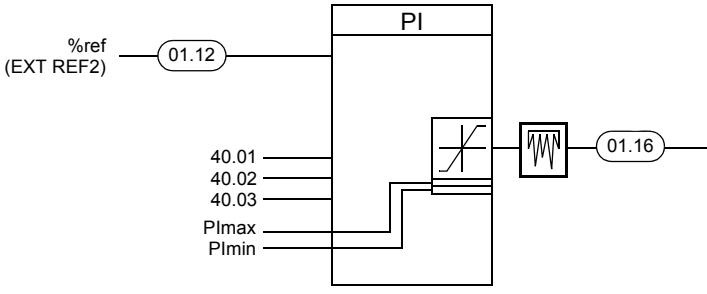
Index	Name/Selection	Description	FbEq
	0 ... 500%	Supervision limit.	0 ... 500
44.20	PROF LIMIT ON DLY	Delay time for the Application Profile protection.	
	0.0 ... 100.0 h	Delay.	0 ... 100
44.21	PI REF FREEZE	<p>Freezes the input of the process PI controller. This feature is useful when the reference is based on an process actual value connected to an analogue input, and the sensor must be serviced without stopping the process.</p> <p>The input of the PI controller is frozen as long as the selected digital input is ON.</p> <p>See also parameter 44.22.</p> 	
	NO	The input of the process PI controller is not frozen.	1
	DI1	Digital input DI1 ON: Input of the process PI controller frozen.	2
	DI2	See selection DI1.	3
	DI3	See selection DI1.	4
	DI4	See selection DI1.	5
	DI5	See selection DI1.	6
	DI6	See selection DI1.	7
	DI7	See selection DI1.	8
	DI8	See selection DI1.	9
	DI9	See selection DI1.	10
	DI10	See selection DI1.	11
	DI11	See selection DI1.	12
	DI12	See selection DI1.	13
44.22	PI OUT FREEZE	<p>Freezes the output of the process PI controller. This feature is useful when the reference is based on process actual value connected to an analogue input, and the sensor must be serviced without stopping the process.</p> <p>The output of the PI controller is frozen as long as the selected digital input is ON.</p> <p>See also parameter 44.21.</p> 	

Index	Name/Selection	Description	FbEq
	NO	The output of the process PI controller is not frozen.	1
	DI1	Digital input DI1 ON: Output of the process PI controller frozen.	2
	DI2	See selection DI1.	3
	DI3	See selection DI1.	4
	DI4	See selection DI1.	5
	DI5	See selection DI1.	6
	DI6	See selection DI1.	7
	DI7	See selection DI1.	8
	DI8	See selection DI1.	9
	DI9	See selection DI1.	10
	DI10	See selection DI1.	11
	DI11	See selection DI1.	12
	DI12	See selection DI1.	13
45	FLOWCONTROL	Set-up of the Flow calculation function. Note: The flow calculation is suitable for single-pump stations that are used to pump water. Note: The flow calculation function is not to be used for invoicing purposes.	
45.01	FLOW MODE	Enables/Disables the flow calculation function.	
	OFF	Disabled	1
	ON	Enabled	2
45.02	SUM FLOW RESET	Resets the total calculated flow counter (actual signal 05.12).	
	OFF	No reset.	1
	ON	Reset. The counter restarts from zero.	2
	FLOW POINTER	Source selected by parameter 45.34 .	3
45.03	MAX INLET PRESSUR	Used to specify the maximum value of the inlet pressure sensor. This value is used in flow calculation when the Q-H performance curve of the pump is used. See also parameters 45.17 and 45.28 .	
	0.00 ... 10000.00 bar	Maximum inlet pressure.	1 = 0.1 bar
45.04	MAX OUTLET PRESSU	Used to specify the maximum value of the outlet pressure sensor. This value is used in flow calculation when the Q-H performance curve of the pump is used. See also parameters 45.17 and 45.29 .	
	0.00 ... 10000.00 bar	Maximum outlet pressure.	1 = 0.1 bar

Index	Name/Selection	Description	FbEq
45.07	Q1	<p>Flow rate (in cubic metres per hour) at point 1 on the Q-H performance curve. Parameters 45.07 ... 45.16 define the Q-H performance curve of the pump for the flow calculation function. The Q (flow rate) and H (head, or level) coordinates of five points on the curve are entered. The values are provided by the pump manufacturer.</p> <p>Below is an example of a Q-H performance curve. The defining parameters of the first and last points are shown.</p>	
	0.0 ... 10000.0 m ³ /h	Flow rate at point 1.	1 = 0.1 m ³ /h
45.08	H1	Head (in metres) at point 1 on the Q-H performance curve.	
	0.0 ... 10000.0 m	Head at point 1.	1 = 0.1 m
45.09	Q2	Flow rate (in cubic metres per hour) at point 2 on the Q-H performance curve.	
	0.0 ... 10000.0 m ³ /h	Flow rate at point 2.	1 = 0.1 m ³ /h
45.10	H2	Head (in metres) at point 2 on the Q-H performance curve.	
	0.0 ... 10000.0 m	Head at point 2.	1 = 0.1 m
45.11	Q3	Flow rate (in cubic metres per hour) at point 3 on the Q-H performance curve.	
	0.0 ... 10000.0 m ³ /h	Flow rate at point 3.	1 = 0.1 m ³ /h
45.12	H3	Head (in metres) at point 3 on the Q-H performance curve.	
	0.0 ... 10000.0 m	Head at point 4.	1 = 0.1 m
45.13	Q4	Flow rate (in cubic metres per hour) at point 4 on the Q-H performance curve.	
	0.0 ... 10000.0 m ³ /h	Flow rate at point 2.	1 = 0.1 m ³ /h
45.14	H4	Head (in metres) at point 4 on the Q-H performance curve.	
	0.0 ... 10000.0 m	Head at point 4.	1 = 0.1 m
45.15	Q5	Flow rate (in cubic metres per hour) at point 5 on the Q-H performance curve.	
	0.0 ... 10000.0 m ³ /h	Flow rate at point 5.	1 = 0.1 m ³ /h
45.16	H5	Head (in metres) at point 5 on the Q-H performance curve.	
	0.0 ... 10000.0 m	Head at point 5.	1 = 0.1 m
45.17	FLOW CALC MODE	Defines whether the Q-H or Q-P performance curve is used for flow calculation.	
	Q-H CURVE	The Q-H performance curve is used for flow calculation. Note: This method entails the use of pressure sensors at both the inlet and the outlet of the pump.	1

Index	Name/Selection	Description	FbEq
	KW-Q CURVE	The Q-P performance curve is used for flow calculation. Note: If the Q-P performance curve of the pump is flat, this method cannot be used.	2
	BOTH	Both the Q-H and Q-P performance curves are used for flow calculation. The transition point between the curves is set by parameter 45.18.	3
45.18	Q H Q KW BRKPOINT	Sets the transition point between the Q-H and Q-P performance curves. The Q-P curve is used at heads higher than the value of this parameter.	
	0.00 ... 1000.00 m	Head breakpoint.	1 = 1 m
45.19	DENSITY	Defines the density of the fluid to be pumped for the flow calculation function.	
	1.0 ... 1000000.0 kg/m ³	Fluid density.	1 = 0.1 kg/m ³
45.20	PUMP KW1	Power input (in kilowatts) of pump at point 1 on the Q-P performance curve. Parameters 45.20 ... 45.25 define the Q-P performance curve of the pump for the flow calculation function. The Q (flow rate) and P (power input) coordinates of three points on the curve are entered. The values are provided by the pump manufacturer. Below is an example of a Q-P performance curve. The defining parameters of the first and last points are shown.	
	0.0 ... 10000.0 kW	Power input of pump at point 1.	1 = 1 kW
45.21	PUMP Q1	Flow rate (in cubic metres per hour) at point 1 on the Q-H performance curve.	
	0.0 ... 10000.0 m ³ /h	Flow rate at point 1.	1 = 1 m ³ /h
45.22	PUMP KW2	Power input (in kilowatts) of pump at point 2 on the Q-P performance curve.	
	0.0 ... 10000.0 kW	Power input of pump at point 2.	1 = 1 kW
45.23	PUMP Q2	Flow rate (in cubic metres per hour) at point 2 on the Q-H performance curve.	
	0.0 ... 10000.0 m ³ /h	Flow rate at point 2.	1 = 1 m ³ /h
45.24	PUMP KW3	Power input (in kilowatts) of pump at point 3 on the Q-P performance curve.	
	0.0 ... 10000.0 kW	Power input of pump at point 3.	1 = 1 kW
45.25	PUMP Q3	Flow rate (in cubic metres per hour) at point 3 on the Q-H performance curve.	
	0.0 ... 10000.0 m ³ /h	Flow rate at point 3.	1 = 1 m ³ /h
45.26	EFFICIENCY	Total efficiency of the motor/pump combination.	
	0.0 ... 100.0%	Efficiency.	1 = 1%
45.27	PUMP NOM SPEED	Defines the nominal speed of the pump in rpm.	
	0 ... 10000 rpm	Nominal speed of pump.	1 = 1 rpm

Index	Name/Selection	Description	FbEq
45.28	PUMP INLET SEL	Selects the analogue input for pump inlet pressure measurement. See also parameter 45.03 .	
	NOT SEL	No analogue input selected.	1
	AI1	Pump inlet pressure measured through selected input.	2
	AI2	Pump inlet pressure measured through selected input.	3
	AI3	Pump inlet pressure measured through selected input.	4
	AI5	Pump inlet pressure measured through selected input.	5
	AI6	Pump inlet pressure measured through selected input.	6
45.29	PUMP OUTLET SEL	Selects the analogue input for pump outlet pressure measurement. See also parameter 45.04 .	
	NOT SEL	No analogue input selected.	1
	AI1	Pump outlet pressure measured through selected input.	2
	AI2	Pump outlet pressure measured through selected input.	3
	AI3	Pump outlet pressure measured through selected input.	4
	AI5	Pump outlet pressure measured through selected input.	5
	AI6	Pump outlet pressure measured through selected input.	6
45.30	FLOW CALC GAIN	Flow calculation gain for possible calculation correction.	
	0.00 ... 10.00	Calculation correction gain.	1 = 1
45.31	PUMP INLET DIAM	The diameter of the pump inlet in metres.	
	0.00 ... 1000.00 m	Pump inlet diameter.	1 = 1 m
45.32	PUMP OUTLET DIAM	The diameter of the pump outlet in metres.	
	0.00 ... 1000.00 m	Pump outlet diameter.	1 = 1 m
45.33	SENSOR HGT DIFF	Height difference between the inlet and outlet pressure sensors.	
	0.00 ... 1000.00 m	Height difference.	1 = 1 m
45.34	FLOW RESET PTR	Defines the source for value FLOW POINTER of parameter 45.02 .	
	-255.255.31 ... +255.255.31 / C.-32768 ... C.32767	Parameter index or a constant value. See Parameter 10.04 for information on the difference.	
45.36	CALC LOW SPEED	Defines a frequency limit for the flow calculation function. When the drive output frequency goes below the limit, the function resets the calculated flow back to zero (0). The calculation restarts once the frequency rises back to the limit or above.	
	0.00 ... 100.00 Hz	Drive output frequency	10 = 1 Hz

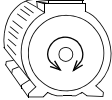
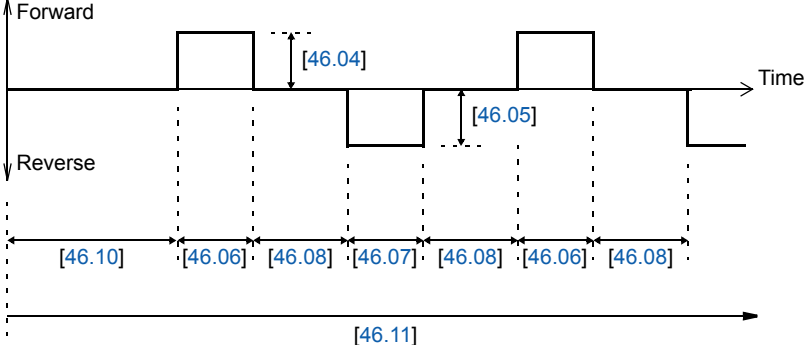
Index	Name/Selection	Description	FbEq
46 ANTI JAM			
46.01	A JAM ENABLE1	<p>Defines when the Anti-jam sequence can be carried out. See also parameter 46.02.</p> <p>The Anti-jam sequence consists of forward and reverse “steps”.</p>   <p>WARNING! Before enabling the Anti-jam function, ensure it is safe to perform the Anti-jam sequence with the connected equipment.</p> <p>Notes:</p> <ul style="list-style-type: none"> • The Anti-jam function overrides the parameter 10.03 DIRECTION. • The Anti-jam function observes the maximum forward and reverse frequencies (parameters 20.01 and 20.02). • The Anti-jam function always uses acceleration time 2 (par. 22.04) and deceleration time 2 (par. 22.05). • The drive must be started and its Run Enable signal present before the Anti-jam sequence can start. 	
	NOT SEL	The Anti-jam function is disabled.	1
	ENABLED	The Anti-jam sequence can be carried out when the drive is started and running.	2
	AJAM POINTER	The Anti-jam function is enabled by the source selected by parameter 46.12 .	3
46.02	A JAM ENABLE MF	Defines whether the Anti-jam sequence is to be carried out when the drive is the master or a follower in a Multipump configuration.	
	MASTER	The Anti-jam sequence can only be carried out when the drive is the master.	1
	FOLLOWER	The Anti-jam sequence can only be carried out when the drive is a follower.	2
	ENABLED	The Anti-jam sequence can be carried out when the drive is either the master or a follower.	3
46.03	A JAM TRIGG MODE	Defines how the Anti-jam sequence is triggered. Note that the conditions set by parameters 46.01 and 46.02 must be fulfilled before the sequence can start.	
	NOT SEL	No triggering source defined.	1
	MOT CURR LEV	The Anti-jam sequence is triggered when the output current of the drive exceeds the limit defined by parameter 46.09 .	2
	DI1 TRIGG	Switching on digital input DI1 triggers the Anti-jam sequence.	3

Index	Name/Selection	Description	FbEq
	DI3 TRIGG	Switching on digital input DI3 triggers the Anti-jam sequence.	4
	IMOT OR DI1	The Anti-jam sequence is triggered when the output current of the drive exceeds the limit defined by parameter 46.09 or digital DI1 is switched on.	5
	IMOT OR DI3	The Anti-jam sequence is triggered when the output current of the drive exceeds the limit defined by parameter 46.09 or digital DI3 is switched on.	6
	AT START	The Anti-jam sequence is performed every time the drive receives a Start command.	7
	TIMETRIGG R	The Anti-jam sequence is started periodically at intervals defined by parameter 46.10.	8
46.04	A JAM FWDSTEPLEV	Forward step frequency for the Anti-jam sequence in percent of nominal motor frequency (parameter 99.07).	
	0.0 ... 200.0 %	Forward step frequency.	0 ... 200
46.05	A JAM REVSTEPLEV	Reverse step frequency for the Anti-jam sequence in percent of nominal motor frequency (parameter 99.07).	
	0.0 ... 200.0 %	Reverse step frequency.	0 ... 200
46.06	A JAM FWDSTEP TIM	Defines the duration of each forward step in an Anti-jam sequence in seconds.	
	0.00 ... 1000.00 s	Forward step duration.	0 ... 1000
46.07	A JAM REVSTEP TIM	Defines the duration of each reverse step in the Anti-jam sequence in seconds.	
	0.00 ... 1000.00 s	Reverse step duration.	0 ... 1000
46.08	A JAM STEP OFFTIM	Defines the length of the interval between forward and reverse steps in the Anti-jam sequence in seconds.	
	0.00 ... 1000.00 s	Step interval.	0 ... 1000
46.09	A JAM I TRIGG LE	The output current limit for parameter 46.03 in amperes.	
	0.00 ... 1000.00 A	Current limit.	0 ... 1000
46.10	A JAM TIMETRIG LE	Time setting for parameter 46.03 in hours.	
	0.00 ... 200.00 h	Time.	0 ... 200
46.11	A JAM COUNT	Number of steps to be performed in the Anti-jam sequence.	
	0 ... 100	Number of steps.	0 ... 200
46.12	A JAM ENB1 POINT	Defines the source for value AJAM POINTER of parameter 46.01.	
	-255.255.31 ... +255.255.31 / C.-32768 ... C.32767	Parameter index or a constant value. See Parameter 10.04 for information on the difference.	-

Index	Name/Selection	Description	FbEq
47 LEVEL CONTROL		The parameters control the Level control function. Only visible and effective when the Level control macro is selected.	
47.02	PUMP DIRECTION	Defines whether the pump station is used for emptying or filling a tank.	
	EMPTYING	<p>The pump station is used for emptying a tank.</p> <p>The diagram below shows the start, stop and supervision levels for emptying. For simplicity, only three pumps are shown. Parameter 47.03 is assumed to be set to COMMON STOP; parameter 47.18 is assumed to be set to 0.00 seconds.</p>	1
<p>The diagram consists of four vertically aligned graphs sharing a common time axis. The top graph shows the tank level (05.23) over time, which rises to a peak and then falls. Key levels are marked on the right: High level 2 (47.17), High level 1 (47.16), Start 3 level (47.10), Start 2 level (47.09), Start 1 level (47.08), Stop level (47.07), Low level 1 (47.05), and Low level 2 (47.06). Below this are three frequency graphs for Pump 3, Pump 2, and Pump 1. Each pump's frequency starts at zero, rises to an efficiency speed (47.20) and then to a high speed (47.21) when its respective start level is reached. The pumps stop when the level reaches the stop level (47.07). Vertical dashed lines connect the start and stop levels of the pumps to the corresponding points on the level graph.</p>			

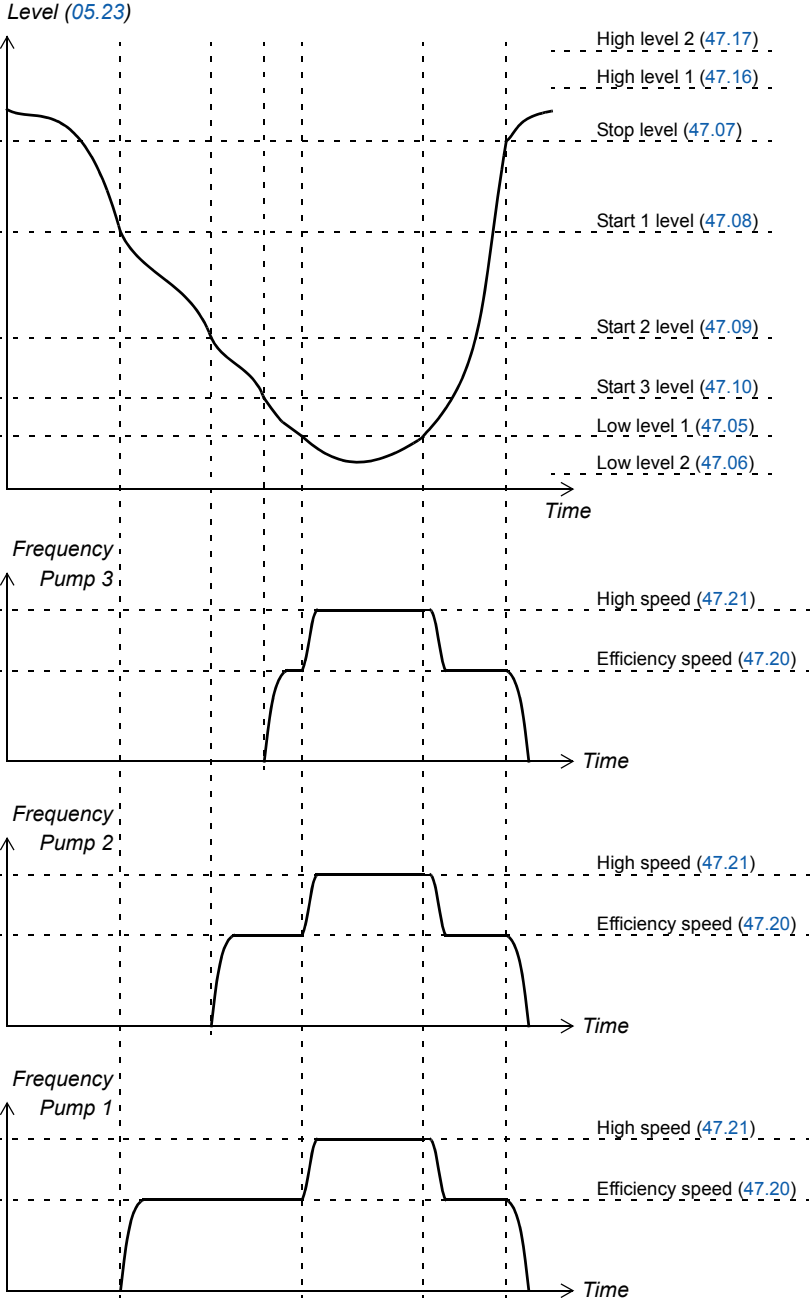
Index	Name/Selection	Description	FbEq
	FILLING	<p>The pump station is used for filling a tank.</p> <p>The diagram below shows the start, stop and supervision levels for filling. For simplicity, only three pumps are shown. Parameter 47.03 is assumed to be set to COMMON STOP; parameter 47.18 is assumed to be set to 0.00 seconds.</p>  <p>The diagram consists of three vertically stacked graphs sharing a common time axis. The top graph, labeled 'Level (05.23)', shows a curve representing the tank's water level. It starts at a high level, drops to a low level, and then rises back to a high level. Vertical dashed lines mark key levels: High level 2 (47.17), High level 1 (47.16), Stop level (47.07), Start 1 level (47.08), Start 2 level (47.09), Start 3 level (47.10), Low level 1 (47.05), and Low level 2 (47.06). The middle graph, 'Frequency Pump 3', shows the frequency of Pump 3. It starts at zero, rises to an efficiency speed when the level reaches Start 1, then to high speed at Start 2, and returns to zero at Stop level. The bottom graph, 'Frequency Pump 2', shows Pump 2 starting at efficiency speed at Start 1 and high speed at Start 2. The bottom-most graph, 'Frequency Pump 1', shows Pump 1 starting at efficiency speed at Start 1 and high speed at Start 2.</p>	2
47.03	CONTROL MODE	Selects whether the pumps are stopped simultaneously or individually.	
	STABLE LEV	When the start level of a pump (parameters 47.08 ... 47.10) is reached, the master drive waits for the level delay (parameter 47.18) to elapse, then stops the pump.	1

Index	Name/Selection	Description	FbEq
	COMMON STOP	All the pumps running will continue to run until the stop level (parameter 47.07) is reached. All pumps will then stop simultaneously.	2
47.04	LEVEL SOURCE SEL	Selects the analogue input to which the level-indicating pressure sensor is connected. The level indicated by this sensor is visible as actual signal 05.23.	
	NOT SEL	No level-indicating pressure sensor connected.	1
	AI1	The level-indicating pressure sensor is connected to analogue input AI1.	2
	AI2	The level-indicating pressure sensor is connected to analogue input AI2.	3
	AI3	The level-indicating pressure sensor is connected to analogue input AI3.	4
	AI5	The level-indicating pressure sensor is connected to analogue input AI5.	5
	AI6	The level-indicating pressure sensor is connected to analogue input AI6.	6
47.05	LOW LEVEL1	Defines LOW LEVEL 1. In emptying, if the measured level falls below LOW LEVEL 1, all pumps stop (if not stopped already). In filling, if the measured level falls below LOW LEVEL 1, all pumps start running at the speed defined by parameter 47.21. See the diagrams at parameter 47.02, and actual signal 05.21.	
	0.00 ... 100.00 %	LOW LEVEL 1.	1 = 1%
47.06	LOW LEVEL 2	Selects a digital input for detecting LOW LEVEL 2. In emptying, receipt of the LOW LEVEL 2 signal causes all pumps to stop (if not stopped already), and the drive to generate a warning. In filling, receipt of the LOW LEVEL 2 signal causes all pumps to run at the speed defined by parameter 47.21, and the drive to generate a warning. See the diagrams at parameter 47.02, and actual signal 05.21.	
	NOT SEL	No sensor connected.	1
	DI2_NO	The LOW LEVEL 2 sensor is connected to digital input DI2. The sensor closes when the level is reached.	2
	DI3_NO	The LOW LEVEL 2 sensor is connected to digital input DI3. The sensor closes when the level is reached.	3
	DI5_NO	The LOW LEVEL 2 sensor is connected to digital input DI5. The sensor closes when the level is reached.	4
	DI9_NO	The LOW LEVEL 2 sensor is connected to digital input DI9. The sensor closes when the level is reached.	5
	DI2_NC	The LOW LEVEL 2 sensor is connected to digital input DI2. The sensor opens when the level is reached.	6
	DI5_NC	The LOW LEVEL 2 sensor is connected to digital input DI5. The sensor opens when the level is reached.	7
	DI9_NC	The LOW LEVEL 2 sensor is connected to digital input DI9. The sensor opens when the level is reached.	8
47.07	STOP LEVEL	Defines the STOP LEVEL for the pump station. If parameter 47.03 is set to STABLE LEV, pumps 3 and 2 are stopped when START3 LEVEL and START2 LEVEL are reached respectively; pump 1 will be stopped at STOP LEVEL. If parameter 47.03 is set to COMMON STOP, all pumps will continue to run until the STOP LEVEL is reached. See the diagrams at parameter 47.02.	
	0.00 ... 100.00 %	STOP LEVEL.	1 = 1%
47.08	START1 LEVEL	Defines the start level for pump 1 (START1 LEVEL). See the diagrams at parameter 47.02.	
	0.00 ... 100.00 %	START1 LEVEL.	1 = 1%

Index	Name/Selection	Description	FbEq
47.09	START2 LEVEL	Defines the start level for pump 2 (START2 LEVEL). This is also the stop level for pump 2 unless COMMON STOP is selected at parameter 47.03. See parameter 47.07, and the diagrams at parameter 47.02.	
	0.00 ... 100.00 %	START2 LEVEL.	1 = 1%
47.10	START3 LEVEL	Defines the start level for pump 3 (START3 LEVEL). This is also the stop level for pump 3 unless COMMON STOP is selected at parameter 47.03. See parameter 47.07, and the diagrams at parameter 47.02.	
	0.00 ... 100.00 %	START3 LEVEL.	1 = 1%
47.11	START4 LEVEL	Defines the start level for pump 4 (START4 LEVEL). This is also the stop level for pump 4 unless COMMON STOP is selected at parameter 47.03. See parameter 47.07, and the diagrams at parameter 47.02.	
	0.00 ... 100.00 %	START4 LEVEL.	1 = 1%
47.12	START5 LEVEL	Defines the start level for pump 5 (START5 LEVEL). This is also the stop level for pump 5 unless COMMON STOP is selected at parameter 47.03. See parameter 47.07, and the diagrams at parameter 47.02.	
	0.00 ... 100.00 %	START5 LEVEL.	1 = 1%
47.13	START6 LEVEL	Defines the start level for pump 6 (START6 LEVEL). This is also the stop level for pump 6 unless COMMON STOP is selected at parameter 47.03. See parameter 47.07, and the diagrams at parameter 47.02.	
	0.00 ... 100.00 %	START6 LEVEL.	1 = 1%
47.14	START7 LEVEL	Defines the start level for pump 7 (START7 LEVEL). This is also the stop level for pump 7 unless COMMON STOP is selected at parameter 47.03. See parameter 47.07, and the diagrams at parameter 47.02.	
	0.00 ... 100.00 %	START7 LEVEL.	1 = 1%
47.15	START8 LEVEL	Defines the start level for pump 8 (START8 LEVEL). This is also the stop level for pump 8 unless COMMON STOP is selected at parameter 47.03. See parameter 47.07, and the diagrams at parameter 47.02.	
	0.00 ... 100.00 %	START8 LEVEL.	1 = 1%
47.16	HIGH LEVEL 1	Defines HIGH LEVEL 1. In emptying, if the measured level exceeds HIGH LEVEL 1, all pumps start running at the speed defined by parameter 47.21. In filling, if the measured level exceeds HIGH LEVEL 1, all pumps stop (if not stopped already). See the diagrams at parameter 47.02, and actual signal 05.21.	
	0.00 ... 100.00 %	HIGH LEVEL 1.	1 = 1%
47.17	HIGH LEVEL 2	Selects a digital input for detecting HIGH LEVEL 2. In emptying, receipt of the HIGH LEVEL 2 signal causes all pumps to run at the speed defined by parameter 47.21, and the drive to generate a warning. In filling, receipt of the HIGH LEVEL 2 signal causes all pumps to stop (if not stopped already), and the drive to generate a warning. See the diagrams at parameter 47.02, and actual signal 05.21.	
	NOT SEL	No sensor connected.	1
	DI2_NO	The HIGH LEVEL 2 sensor is connected to digital input DI2. The sensor closes when the level is reached.	2
	DI3_NO	The HIGH LEVEL 2 sensor is connected to digital input DI3. The sensor closes when the level is reached.	3
	DI5_NO	The HIGH LEVEL 2 sensor is connected to digital input DI5. The sensor closes when the level is reached.	4

Index	Name/Selection	Description	FbEq
	DI9_NO	The HIGH LEVEL 2 sensor is connected to digital input DI9. The sensor closes when the level is reached.	5
	DI2_NC	The HIGH LEVEL 2 sensor is connected to digital input DI2. The sensor opens when the level is reached.	6
47.18	LEVEL DELAY	Sets a delay for the STOP, START1, START2 and START3 levels. Whenever one of these levels is reached, this delay must elapse before any action is taken.	
	0.00 ... 100.00 s	Level delay.	1 = 1 s
47.19	RANDOM COEF	Randomises the START1, START2 and START3 levels (parameters 47.08 to 47.10) to avoid caking on the walls of the tank. For example, if this parameter is set to 10.00%, the actual start level is randomised between (STARTx LEVEL parameter value) - 10% and (STARTx LEVEL parameter value) + 10%.	
	0.00 ... 10.00 %	Random coefficient.	1 = 1%
47.20	EFFICIENCY SPEED	Sets the "efficiency speed", i.e. the optimal operating point of the pumps. A pump is run at this speed when the measured level is between the STARTx LEVEL and HIGH LEVEL 1 of the pump. See the diagrams at parameter 47.02.	
	0.00 ... 100.00 %	Efficiency speed.	1 = 1%
47.21	HIGH LEVEL SPEED	Sets a fixed reference speed for the pumps. This speed is used when the measured level exceeds (emptying) or falls below (filling) the level set by parameter 47.16. See the diagrams at parameter 47.02.	
	0.0 ... 100.0 %	Fixed reference.	1 = 1%
49 ENERGY OPT		Energy optimization settings	
49.01	ENERGY TARIFF1	Price of energy per kWh. Used for reference when savings are calculated. See parameters 01.50 SAVED KWH, 01.52 SAVED AMOUNT and 01.54 SAVED CO2.	
	0.000...1024.000	Price of energy per kWh.	1 = 0.001
49.02	E TARIFF UNIT	Specifies the currency used for the savings calculation.	
	LOCAL	The currency is determined by the setting of parameter 99.01 Language.	0
	EUR	Euro	1
	USD	US dollar	2
49.03	PUMP REF POWER	Pump power when connected directly to supply. Used for reference when energy savings are calculated. See parameters 01.50 SAVED KWH, 01.52 SAVED AMOUNT and 01.54 SAVED CO2.	
	0... 950%	Pump power in percent of nominal motor power. Note: The maximum value depends on the motor and is calculated in power-up or when the motor power changes.	1000 = 100%
49.04	ENERGY RESET	Resets the energy counters 01.50 SAVED KWH, 01.51 SAVED GWH, 01.52 SAVED AMOUNT, 01.53 SAVED AMOUNT M, 01.54 SAVED CO2 and 01.55 SAVED CO2 KTON.	
	DONE	Reset not requested (normal operation).	0
	RESET	Reset energy counters. The value reverts automatically to DONE.	1
51 COMM MOD DATA		The parameters are visible and need to be adjusted, only when a fieldbus adapter module (optional) is installed and activated by parameter 98.02. For details on the parameters, refer to the manual of the fieldbus module and the chapter <i>Fieldbus control</i> . These parameter settings will remain the same even though the macro is changed.	

Index	Name/Selection	Description	FbEq
52 STANDARD MODBUS		The settings for the Standard Modbus Link. See the chapter <i>Fieldbus control</i> .	
52.01	STATION NUMBER	Defines the address of the device. Two units with the same address are not allowed on-line.	
	1 ... 247	Address.	1 ... 247
52.02	BAUDRATE	Defines the transfer rate of the link.	
	600	600 bit/s	1
	1200	1200 bit/s	2
	2400	2400 bit/s	3
	4800	4800 bit/s	4
	9600	9600 bit/s	5
	19200	19200 bit/s	6
52.03	PARITY	Defines the use of parity and stop bit(s). The same setting must be used in all on-line stations.	
	NONE1STOPBIT	No parity bit, one stop bit.	1
	NONE2STOPBIT	No parity bit, two stop bits.	2
	ODD	Odd parity indication bit, one stopbit.	3
	EVEN	Even parity indication bit, one stopbit.	4
60 MASTER-FOLLOWER		Settings for Multipump Control.	
60.01	PUMP NODE	Node number for the drive on the Multipump link. Note: Each drive on the Multipump link must be given a unique node number. Note: If the drive is not given a priority class, this address is used in determining the starting order of pumps.	
	1 ... 125	Node address.	1 ... 8
60.02	FOLLOWER MODE	Selects the source of reference when the drive is a follower.	

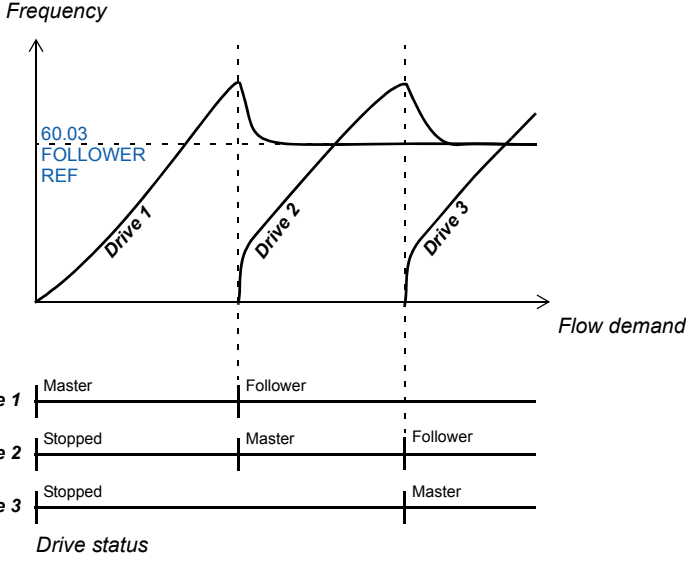
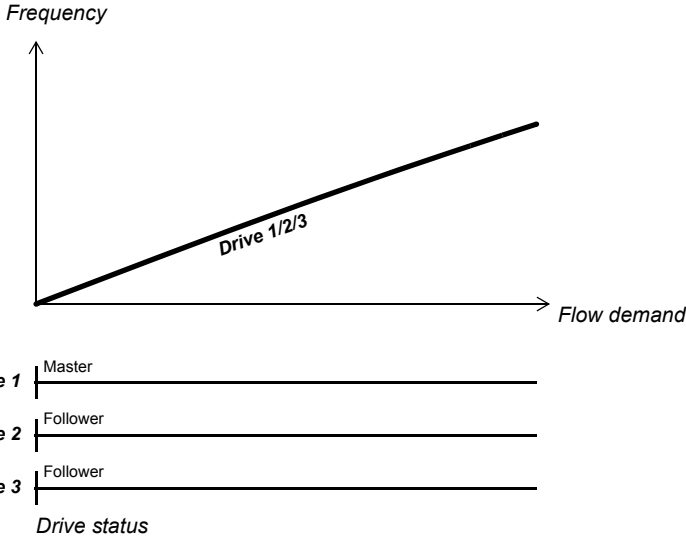
Index	Name/Selection	Description	FbEq
	<p>AUTO</p>	<p>Drives are started and stopped by the Multipump control logic in the master drive. The master receives its reference from the PI controller.</p> <p>When flow demand increases, new pumps are started. The latest drive to start becomes the master; at the same time, the previously-started drive becomes a follower and starts to follow the reference defined by parameter 60.03.</p>  <p>See also the diagrams at parameter 60.03.</p>	<p>1</p>
	<p>SYNC</p>	<p>The drive follows the same start/stop commands and reference (from the PI controller) as the master.</p> <p>With the SYNC setting, the drive does not become master when started. In this example, drive 1 is master; drives 2 and 3 have parameter 60.02 set to SYNC.</p> 	<p>2</p>

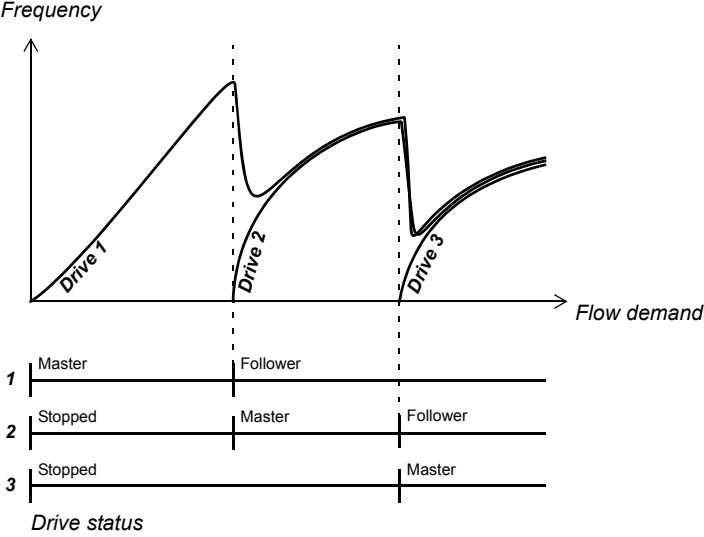
Index	Name/Selection	Description	FbEq												
	REF SYNC	<p>The drive follows the same reference (from the PI controller) as the master, but is started and stopped by the multipump logic. This is usually the most economical follower mode.</p>  <p>The graph plots Frequency on the y-axis and Flow demand on the x-axis. Three curves represent Drive 1, Drive 2, and Drive 3. Drive 1 starts at the origin and ramps up to a peak. At a certain flow demand, Drive 2 becomes the master and its frequency curve follows Drive 1's path. Drive 1 then becomes a follower. Later, Drive 3 becomes the master, and its frequency curve follows Drive 2's path. Drive 2 then becomes a follower. The frequency curve shows some overshoot and settling time when the master drive changes.</p> <p>Below the graph is a 'Drive status' table:</p> <table border="1" data-bbox="568 763 1166 904"> <thead> <tr> <th>Drive</th> <th>Master</th> <th>Follower</th> </tr> </thead> <tbody> <tr> <td>Drive 1</td> <td>Master</td> <td>Follower</td> </tr> <tr> <td>Drive 2</td> <td>Stopped</td> <td>Master</td> </tr> <tr> <td>Drive 3</td> <td>Stopped</td> <td>Master</td> </tr> </tbody> </table> <p>In case the master status switches from one drive to another and the reference changes drastically, the drive compares the most recent reference value with the previous reference. If the difference between the references is more than 10%, the follower will accelerate/decelerate towards the new reference along a ramp. The acceleration and deceleration ramps are defined by parameters 60.23 and 60.24 respectively. The ramp-up or ramp-down will end when the new reference is reached.</p>	Drive	Master	Follower	Drive 1	Master	Follower	Drive 2	Stopped	Master	Drive 3	Stopped	Master	3
Drive	Master	Follower													
Drive 1	Master	Follower													
Drive 2	Stopped	Master													
Drive 3	Stopped	Master													

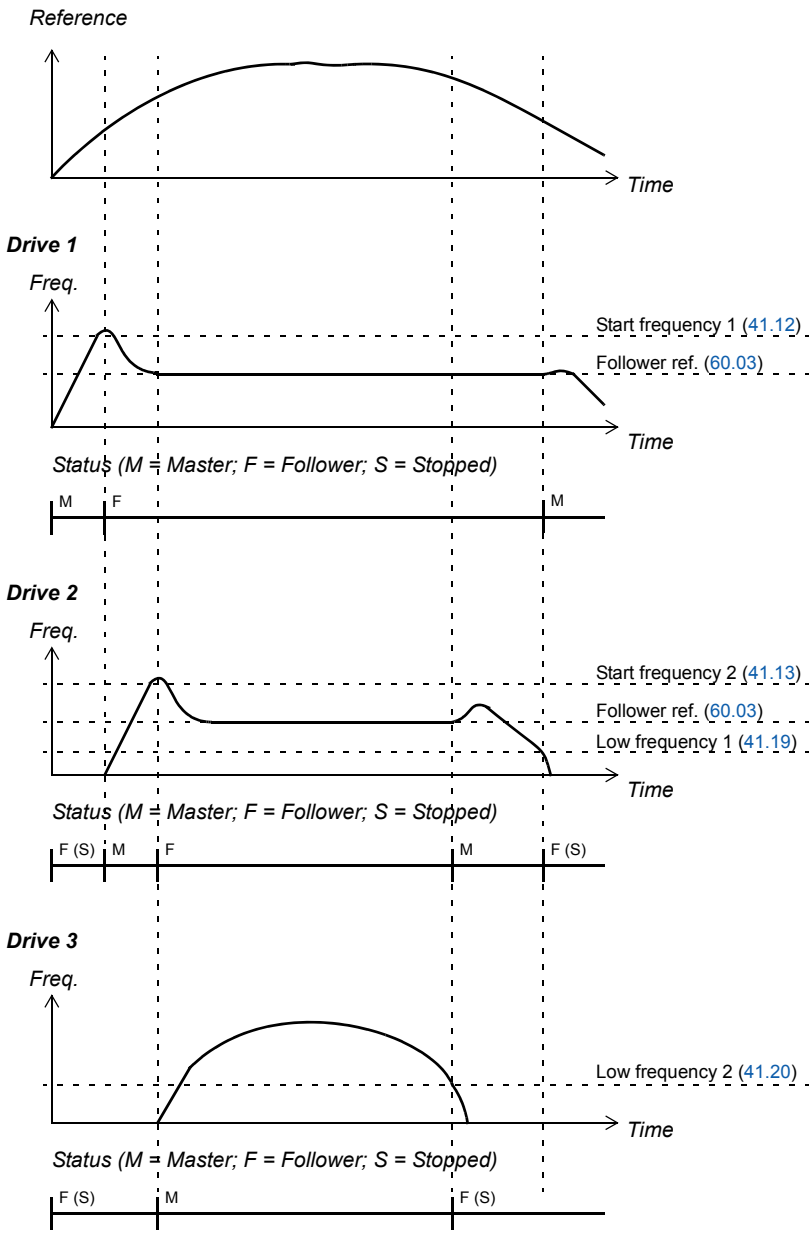
Index	Name/Selection	Description	FbEq
60.03	FOLLOWER REF	<p>Only visible when the Multipump macro is selected (parameter 99.02 is set to MULTIMASTER).</p> <p>This parameter defines the reference used when parameter 60.02 is set to AUTO, and the drive is running as a follower.</p> <p>The following diagram illustrates the starting of the drives in a typical multipump configuration as the reference (flow demand) first increases, then decreases. Follower start and stop delays (see parameters 41.26 and 41.27) are ignored in this presentation.</p> 	
	0 ... 120 Hz	Reference setting. This should generally be set at the optimal operating point of the pump.	0 ... 120
60.04	AUTOCHANGE STYLE	Selects whether the Autochange function is used.	

Index	Name/Selection	Description	FbEq
	NO	Autochange disabled. When several pumps are running, the master is the drive with the highest node number (60.01).	0
	FIXED	Autochange will occur at intervals set by parameter 60.05. Note: The timing is based on the time the drives are powered (but not necessarily running).	1
	HOURCOUNT	The pumping duty is distributed among the pumps according to parameters 60.09 to 60.11. Note: The timing is based on the time the pumps are actually running.	2
	ALL STOP	Autochange will occur when all drives are stopped.	3
60.05	AUTOCHANGE INTERV	Specifies the Autochange interval for Multipump Control when parameter 60.04 is set to FIXED. The time elapsed since the last Autochange is indicated by actual signal 01.42.	
	3 ... 12285 min	Autochange interval. Note: Use intervals divisible by 3, i.e. 3,6,9,12, etc.	1 = 1 min
60.07	NUM PUMPS ALLOWED	Defines the maximum number of pumps that can be run simultaneously in a Multipump application. This number does not include drives running in SYNC follower mode (see parameter 60.02).	
	0 ... 8	Maximum number of pumps.	0 ... 8
60.08	MASTER ENABLE	Selects whether the drive is allowed to be the master drive in the Multipump configuration.	
	YES	The drive is allowed to be the master in the Multipump configuration.	1
	NO	The drive is not allowed to be the master in the Multipump configuration.	2
	DI1	When the digital input is ON, the drive is allowed to be the master in the Multipump configuration.	3
	DI2	See selection DI1.	4
	DI3	See selection DI1.	5
	DI4	See selection DI1.	6
	DI5	See selection DI1.	7
	DI6	See selection DI1.	8
	DI7	See selection DI1.	9
	DI8	See selection DI1.	10
	DI9	See selection DI1.	11
	DI10	See selection DI1.	12
	DI11	See selection DI1.	13
	DI12	See selection DI1.	14
60.09	PUMP RUNTIME SEL	Controls the pump runtime setting.	
	NO	Parameter 60.10 is read-only.	0
	SET	Parameter 60.10 can be adjusted. The setting will automatically revert to NO afterwards.	1
	RESET	Resets parameter 60.10. The setting will automatically revert to NO afterwards.	2
60.10	PUMP RUNTIME	Pump runtime counter. Can be manually adjusted provided that SET is selected at parameter 60.09.	
	0 ... 8988479 h	Runtime counter.	1 = 1 h
60.11	PUMP RUNTIME DIFF	Maximum pump runtime difference between drives. The application program will compare the values of parameter 60.10 in each drive on the Multipump link and attempt to keep the runtime difference below this value.	

Index	Name/Selection	Description	FbEq
	0 ... 8988479 h	Runtime difference between drives.	1 = 1 h
60.12	PUMP CLASS SEL	Selects the start priority for the drive. The drive can be given a fixed priority, or a digital input can be used to switch between two priorities. Please note that the Autochange feature will attempt to equalise the duty between pumps with the same priority – not between pumps with different priorities.	
	PAR CLASS1	Start priority defined by parameter 60.13.	1
	PAR CLASS2	Start priority defined by parameter 60.14.	2
	DI1	The digital input selects between two pre-set priorities defined by parameters 60.13 and 60.14. OFF = Pump class 1 (parameter 60.13), ON = Pump class 2 (parameter 60.14).	3
	DI2	See selection DI1.	4
	DI3	See selection DI1.	5
	DI4	See selection DI1.	6
	DI5	See selection DI1.	7
	DI6	See selection DI1.	8
	DI7	See selection DI1.	9
	DI8	See selection DI1.	10
	DI9	See selection DI1.	11
	DI10	See selection DI1.	12
	DI11	See selection DI1.	13
	DI12	See selection DI1.	14
60.13	PUMP CLASS1	Defines the priority for pump class 1.	
	1 ... 4	Priority. 1 = highest priority = first to start.	
60.14	PUMP CLASS2	Defines the priority for pump class 2.	
	1 ... 4	Priority. 1 = highest priority = first to start.	
60.17	MASTER LOSS	In case the drive is a follower, cannot find a master on the Multipump link and is not itself allowed to be master, the drive will wait for the delay specified by parameter 60.19, then proceed as defined by this parameter. A warning	
	CONST SPEED	The drive continues running and adopts the speed defined by parameter 12.04.	1
	LAST SPEED	The drive continues to run at the last valid reference received from the master.	2
60.18	F T M COMM LOSS	In case the drive is a follower on the Multipump link, and the master cannot receive messages from it, the drive will wait for the delay specified by parameter 60.19, then proceed as defined by this parameter.	
	CNST SPEED	The drive starts (if not running already) and adopts the speed defined by parameter 12.04.	1
	LAST SPEED	The drive continues to run according to the last valid reference received from the master.	2
	SYNC SPEED	The drive starts (if not running already) and uses the speed reference received from the master.	3
	FOLL CTRL	The drive starts (if not running already) and follows the output of its own PI controller. Communication-wise, the drive remains a follower.	4
60.19	COMM DELAY	After the drive detects a master/follower communication break, it will wait until the delay specified by this parameter, then proceed as defined by parameter 60.17 or 60.18 (depending on the nature of the communication break).	
	0.0 ... 3600.0 s	Delay.	0 ... 3600

Index	Name/Selection	Description	FbEq
60.20	ALL FOLL LOST	In case the drive is the master on a Multipump link, and does not receive messages from any of the followers, the drive will proceed as defined by this parameter.	
	CONTINUE	No action taken.	0
	RARE POLLING	The drive switches to "rare polling", i.e. starts to read and send messages at two-second intervals. The drive will revert to normal messaging after followers are detected. Note: Do not use this setting if the drives are connected in a ring; use "CONTINUE" instead.	1
60.21	MIN PUMP	Defines the minimum number of drives that can be run simultaneously in a Multipump application. This number does not include drives running in SYNC follower mode (see parameter 60.02). Note: If the value received from the pointer is less than 2, no minimum limitation exists. Note: The drives that are kept running ignore the low (stop) frequencies defined in parameter group 41 PFC-CONTROL 1.	
	-255.255.31 ... +255.255.31 / C.-32768 ... C.32767	Parameter index or a constant value. See Parameter 10.04 for information on the difference.	-
60.22	INV ORDER CORR	<p>Whenever the application requires more pumping volume, additional drives are started. The starting order is dependent on the priority the drive is assigned to (parameters 60.12 to 60.14). Whenever several drives have the same priority, the one with the lowest node number (60.01) is started first by default.</p> <p>The Autochange function can be used to automatically rotate the starting order within each priority group. Drives running before the Autochange may continue to run so that the new starting order cannot be applied immediately; this parameter defines the method with which the drive order of priority is corrected.</p> <p><i>Example:</i></p> <p>One pump is running. If necessary, additional pumps are started in the following order:</p> <div style="text-align: center;"> </div> <p>While there is constant flow demand (and a pump must be running), the Autochange function is activated, rotating the starting order within each priority. After Autochange, the order is as follows:</p> <div style="text-align: center;"> </div> <p>The desired order is, however, this:</p> <div style="text-align: center;"> </div> <p>The setting of this parameter defines how the desired order is achieved. See the available selections below.</p>	
	OPT CONTROL	Drive order of priority is corrected only when the number of drives needs to be increased or decreased by the master as required by the process.	0
	FORCED STOP	Drive order of priority is corrected as soon as possible by stopping low-priority drives. Higher-priority drives are then started as required by the process.	1

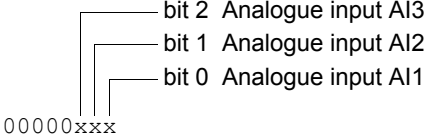
Index	Name/Selection	Description	FbEq
60.23	RAMP ACCEL TIME	Defines the acceleration time in case the latest reference received by the drive is higher than the previous reference. This is likely to happen when the master status is passed on from one drive to another. The parameter sets the ramp-up time as seconds from zero to maximum frequency (not from previous reference to new reference). See parameter 60.02 . The parameter is effective only in the SYNC and REF SYNC follower modes.	
	0.1 ... 3600.00 s	Acceleration time.	1 = 1 s
60.24	RAMP DECEL TIME	Defines the deceleration time in case the latest reference received by the drive is lower than the previous reference. This is likely to happen when the master status is passed on from one drive to another. The parameter sets the ramp-down time as seconds from maximum frequency to zero (not from previous reference to new reference). See parameter 60.02 . The parameter is effective only in the SYNC and REF SYNC follower modes.	
	0.1 ... 3600.00 s	Deceleration time.	1 = 1 s
60.25	MASTER LOCATION	Defines whether the master status is passed on with each started drive.	
	STABLE	The first drive started will remain the master as long as possible, i.e. until, for example, the drive is no longer allowed to be master (see parameter 60.08), or the drive trips on a fault.	0
	IN STARTED	The last-started drive that is allowed to be master by parameter 60.08 is the master.	1
65 SHARE IO		Settings for shared analogue input signals.	
65.01	SHARE IO ACTIVE	The analogue input (AI1 to AI3) signals connected to one drive can be read by the master and broadcast via the fibre optic link to all other drives. By default, the source is the drive with node address 1. If desired, the drive with node address 2 can be defined as a secondary source (parameter 65.03), used whenever communication with node 1 fails. Setting this parameter to YES enables input signal sharing. The shared data will then be visible as actual signals 05.15 , 05.16 and 05.17 . Note that the shared signals will only override the physical inputs of the drive if allowed by parameter 65.02 .	
	NO	Input signal sharing disabled.	1
	YES	Input signal sharing enabled.	2
65.02	REPLACE IO	Defines which physical inputs of the drive are overridden by shared input values broadcast by the master. The shared input data takes preference over the physical inputs whose bit is set to 1. 	
	0000000 ... 11111111	Selector for drive inputs to be overridden by shared input data.	
65.03	SECONDARY SOURCE	Enables/disables the use of another drive (node 2) as a source of digital and analogue input signals in case communication with node 1 is lost. Reading the inputs from node 2 is started after the delay defined by parameter 65.05 has elapsed. This parameter is only effective when the drive is master.	
	NO	No secondary source is used.	0
	NODE 2	If the drive with node address 1 is not available, the drive with node address 2 is used as the source of the analogue and digital input signals.	1

Index	Name/Selection	Description	FbEq
65.04	SHARE IO COM LOST	Defines the action to be taken in case the shared input values are not received. The parameter applies regardless of whether the drive is the master (and does not receive messages from node 1, or node 2 if it is selected as a secondary source) or a follower (and does not receive messages from the master). In either case, the drive will wait for the delay specified by parameter 65.05, then proceed as defined by this parameter.	
	CONTINUE	The drive will continue running based on the last valid data received.	1
	CONST SPEED	The drive will continue running at the frequency defined by parameter 12.04 (constant frequency 3).	2
	FAULT	The drive will trip and produce a fault (SHARE IO COMM LOSS).	3
65.05	IO COM LOST DELAY	Delay for the communication loss function.	
	1.0 s ... 3600.0 s	Delay.	1 = 1 s
70 DDCS CONTROL		Settings for the fibre optic channels 0, 1 and 3.	
70.01	CH0 NODE ADDR	Defines the node address for channel 0. No two nodes on-line may have the same address. The setting needs to be changed when a master station is connected to channel 0 and it does not automatically change the address of the slave. Examples of such masters are an ABB Advant Controller or another drive.	
	1 ... 254	Address.	1 ... 125
70.02	CH3 NODE ADDR	Node address for channel 3. No two nodes on-line may have the same address. Typically the setting needs to be changed when the drive is connected in a ring which consists of several drives and a PC with the DriveWindow® program running.	
	1 ... 254	Address.	1 ... 254
70.03	CH2 HW CONNECTION	Defines the topology of the Multipump configuration.	
	STAR	The drives are connected in a star topology, i.e. through an NDBU-95 branching unit. Note: The NDBU-95 must have the REGEN communication mode enabled.	1
	RING	The drives are connected in a ring topology.	65535
83 ADAPT PROG CTRL		Control of the Adaptive Program execution. For more information, see the <i>Adaptive Program Application Guide</i> (code: 3AFE 64527274 [English]).	
83.01	ADAPT PROG CMD	Selects the operation mode for the Adaptive Program.	
	STOP	Stop. The program cannot be edited.	1
	START	Run. The program cannot be edited.	2
	EDIT	Stop to edit mode. The program can be edited.	3
83.02	EDIT CMD	Selects the command for the block placed in the location defined by parameter 83.03. The program must be in editing mode (see parameter 83.01).	
	NO	Home value. The value automatically restores to NO after an editing command has been executed.	1

Index	Name/Selection	Description	FbEq
	PUSH	Shifts the block in location defined by parameter 83.03 and the following blocks one location up. A new block can be placed in the emptied location by programming the Block Parameter Set as usual. <i>Example:</i> A new block needs to be placed in between the current block number four (parameters 84.20 ... 84.25) and five (parameters 84.25 ... 84.29). In order to do this: - Switch the program to editing mode by parameter 83.01 . - Select location number five as the desired location for the new block by parameter 83.03 . - Shift the block in location number 5 and the following blocks one location forward by parameter 83.02 (selection PUSH). - Program the emptied location number 5 by parameters 84.25 to 84.29 as usual.	2
	DELETE	Deletes the block in location defined by parameter 83.03 and shifts the following blocks one step down.	3
	PROTECT	Activation of the Adaptive Program protection. Activate as follows: - Ensure the Adaptive Program operation mode is START or STOP (parameter 83.01). - Set the passcode (parameter 83.05). - Change parameter 83.02 to PROTECT. When activated: - All parameters in group 84 excluding the block output parameters are hidden (read protected). - It is not possible to switch the program to the editing mode (parameter 83.01). - Parameter 83.05 is set to 0.	4
	UNPROTECT	Deactivation of the Adaptive Program protection. Deactivate as follows: - Ensure the Adaptive Program operation mode is START or STOP (parameter 83.01). - Set the passcode (parameter 83.05). - Change parameter 83.02 to UNPROTECT. Note: If the passcode is lost, it is possible to reset the protection also by changing the application macro setting (parameter 99.02).	5
83.03	EDIT BLOCK	Defines the block location number for the command selected by parameter 83.02 .	
	0 ... 15	Block location number.	1 = 1
83.04	TIMELEV SEL	Selects the execution cycle time for the Adaptive Program. The setting is valid for all blocks.	
	12 ms	12 milliseconds	1
	100 ms	100 milliseconds	2
	1000 ms	1000 milliseconds	3
83.05	PASSCODE	Sets the passcode for the Adaptive Program protection. The passcode is needed at activation and deactivation of the protection. See parameter 83.02 .	
	0 ...	Passcode. The setting reverts to 0 after the protection is activated / deactivated. Note: When activating, write down the passcode and store it in a safe place.	

Index	Name/Selection	Description	FbEq																											
84 ADAPTIVE PROGRAM		- selections of the function blocks and their input connections. - diagnostics For more information, see the <i>Adaptive Program Application Guide</i> (code: 3AFE 64527274 [English]).																												
84.01	STATUS	Shows the value of the Adaptive Program status word. The table below shows the alternative bit states and the corresponding values on the panel display. <table border="1" data-bbox="534 510 1066 801"> <thead> <tr> <th>Bit</th> <th>Display</th> <th>Meaning</th> </tr> </thead> <tbody> <tr> <td>0</td> <td>1</td> <td>Stopped</td> </tr> <tr> <td>1</td> <td>2</td> <td>Running</td> </tr> <tr> <td>2</td> <td>4</td> <td>Faulted</td> </tr> <tr> <td>3</td> <td>8</td> <td>Editing</td> </tr> <tr> <td>4</td> <td>10</td> <td>Checking</td> </tr> <tr> <td>5</td> <td>20</td> <td>Pushing</td> </tr> <tr> <td>6</td> <td>40</td> <td>Popping</td> </tr> <tr> <td>8</td> <td>100</td> <td>Initialising</td> </tr> </tbody> </table>	Bit	Display	Meaning	0	1	Stopped	1	2	Running	2	4	Faulted	3	8	Editing	4	10	Checking	5	20	Pushing	6	40	Popping	8	100	Initialising	
Bit	Display	Meaning																												
0	1	Stopped																												
1	2	Running																												
2	4	Faulted																												
3	8	Editing																												
4	10	Checking																												
5	20	Pushing																												
6	40	Popping																												
8	100	Initialising																												
84.02	FAULTED PAR	Points out the faulted parameter in the Adaptive Program.																												
84.05	BLOCK1	Selects the function block for Block Parameter Set 1. See the <i>Adaptive Program Application Guide</i> (code: 3AFE 64527274 [English]).																												
	ABS		11																											
	ADD		10																											
	AND		2																											
	BWISE		26																											
	COMPARE		16																											
	COUNT		21																											
	DPOT		23																											
	EVENT		20																											
	FILTER		13																											
	MASK-SET		24																											
	MAX		17																											
	MIN		18																											
	MULDIV		12																											
	NO		1																											
	OR		3																											
	PI		14																											
	PI-BAL		15																											
	PI-NEG		25																											
	RAMP		22																											
	SR		5																											
	SWITCH-B		7																											
	SWITCH-I		19																											
	TOFF		9																											
	TON		8																											
	TRIGG		6																											

Index	Name/Selection	Description	FbEq
	XOR		4
84.06	INPUT1	Selects the source for input I1 of Block Parameter Set 1.	
	-255.255.31 ... +255.255.31 / C.-32768 ... C.32767	Parameter index or a constant value: - Parameter pointer: Inversion, group, index and bit fields. The bit number is effective only for blocks handling boolean inputs. - Constant value: Inversion and constant fields. Inversion field must have value C to enable the constant setting. <i>Example:</i> The state of digital input DI2 is connected to Input 1 as follows: - Set this parameter to +.01.17.01. (The application program stores the state of digital input DI2 to bit 1 of actual signal 01.17.) - For an inverted value, reverse the sign of the pointer value (-01.17.01.).	-
84.07	INPUT2	Selects the source for input I2 of Block Parameter Set 1.	
	-255.255.31 ... +255.255.31 / C.-32768 ... C.32767	See parameter 84.06 .	-
84.08	INPUT3	Selects the source for input I3 of Block Parameter Set 1.	
	-255.255.31 ... +255.255.31 / C.-32768 ... C.32767	See parameter 84.06 .	-
84.09	OUTPUT	Stores and displays the output of Block Parameter Set 1.	
84.10	BLOCK2	See parameter 84.05 .	
84.11	INPUT1	Selects the source for input I1 of Block Parameter Set 2.	
	-255.255.31 ... +255.255.31 / C.-32768 ... C.32767	See parameter 84.06 .	-
84.12	INPUT2	Selects the source for input I2 of Block Parameter Set 2.	
	-255.255.31 ... +255.255.31 / C.-32768 ... C.32767	See parameter 84.06 .	-
84.13	INPUT3	Selects the source for input I3 of Block Parameter Set 2.	
	-255.255.31 ... +255.255.31 / C.-32768 ... C.32767	See parameter 84.06 .	-
84.14	OUTPUT	Stores and displays the output of Block Parameter Set 2.	
...	...		
84.79	OUTPUT	Stores and displays the output of Block Parameter Set 15.	
85 USER CONSTANTS		Storage of the Adaptive Program constants and messages. For more information, see the <i>Adaptive Program Application Guide</i> (code: 3AFE 64527274 [English]).	
85.01	CONSTANT1	Sets a constant for the Adaptive Program.	
	-8388608 to 8388607	Integer value.	
85.02	CONSTANT2	Sets a constant for the Adaptive Program.	
	-8388608 to 8388607	Integer value.	
85.03	CONSTANT3	Sets a constant for the Adaptive Program.	
	-8388608 to 8388607	Integer value.	
85.04	CONSTANT4	Sets a constant for the Adaptive Program.	

Index	Name/Selection	Description	FbEq
	-8388608 to 8388607	Integer value.	
85.05	CONSTANT5	Sets a constant for the Adaptive Program.	
	-8388608 to 8388607	Integer value.	
85.06	CONSTANT6	Sets a constant for the Adaptive Program.	
	-8388608 to 8388607	Integer value.	
85.07	CONSTANT7	Sets a constant for the Adaptive Program.	
	-8388608 to 8388607	Integer value.	
85.08	CONSTANT8	Sets a constant for the Adaptive Program.	
	-8388608 to 8388607	Integer value.	
85.09	CONSTANT9	Sets a constant for the Adaptive Program.	
	-8388608 to 8388607	Integer value.	
85.10	CONSTANT10	Sets a constant for the Adaptive Program.	
	-8388608 to 8388607	Integer value.	
85.11	STRING1	Stores a message to be used in the Adaptive Program (EVENT block).	
	MESSAGE1	Message. The value can be edited using the DriveWindow [®] tool.	
85.12	STRING2	Stores a message to be used in the Adaptive Program (EVENT block).	
	MESSAGE2	Message. The value can be edited using the DriveWindow [®] tool.	
85.13	STRING3	Stores a message to be used in the Adaptive Program (EVENT block).	
	MESSAGE3	Message. The value can be edited using the DriveWindow [®] tool.	
85.14	STRING4	Stores a message to be used in the Adaptive Program (EVENT block).	
	MESSAGE4	Message. The value can be edited using the DriveWindow [®] tool.	
85.15	STRING5	Stores a message to be used in the Adaptive Program (EVENT block).	
	MESSAGE5	Message. The value can be edited using the DriveWindow [®] tool.	
90 D SET REC ADDR		- Addresses into which the received fieldbus data sets are written. - Numbers of the main and auxiliary data sets. The parameters are visible only when a fieldbus communication is activated by parameter 98.02 . For more information, see the chapter Fieldbus control .	
90.01	AUX DS REF3	Selects the address into which the value of fieldbus reference REF3 is written.	
	0 ... 8999	Parameter index.	0 ... 8999
90.02	AUX DS REF4	Selects the address into which the value of fieldbus reference REF4 is written.	
	0 ... 8999	Parameter index.	0 ... 8999
90.03	AUX DS REF5	Selects the address into which the value of fieldbus reference REF5 is written.	
	0 ... 8999	Parameter index.	0 ... 8999
90.04	MAIN DS SOURCE	Defines the data set from which the drive reads the Control Word, Reference REF1 and Reference REF2.	
	1 ... 255	Data set number.	1 ... 255
90.05	AUX DS SOURCE	Defines the data set from which the drive reads References REF3, REF4 and REF5.	
	1 ... 255	Data set number.	1 ... 255

Index	Name/Selection	Description	FbEq
92 D SET TR ADDR		Main and Auxiliary Data Sets which the drive sends to the fieldbus master station. The parameters are visible only when a fieldbus communication is activated by parameter 98.02 . For more information, see the chapter Fieldbus control .	
92.01	MAIN DS STATUS WORD	Stores the address from which the Main Status Word is read from. Fixed value, not visible.	
	302 (fixed)	Parameter index.	302
92.02	MAIN DS ACT1	Selects the address from which the Actual Signal 1 is read to the Main Data Set.	
	0 ... 9999	Parameter index.	0 ... 9999
92.03	MAIN DS ACT2	Selects the address from which the Actual Signal 2 is read to the Main Data Set.	
	0 ... 9999	Parameter index.	0 ... 9999
92.04	AUX DS ACT3	Selects the address from which the Actual Signal 3 is read to the Auxiliary Data Set.	
	0 ... 9999	Parameter index.	0 ... 9999
92.05	AUX DS ACT4	Selects the address from which the Actual Signal 4 is read to the Auxiliary Data Set.	
	0 ... 9999	Parameter index.	0 ... 9999
92.06	AUX DS ACT5	Selects the address from which the Actual Signal 5 is read to the Auxiliary Data Set.	
	0 ... 9999	Parameter index.	0 ... 9999

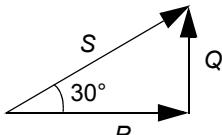
Index	Name/Selection	Description	FbEq
95 HARDWARE SPECIFI		Miscellaneous hardware-related settings.	
95.06	LCU Q POW REF	<p>Defines the reference value for the line-side converter reactive power generation. Line-side converter can generate reactive power to the supply network. This reference is written into line-side converter unit parameter 24.02 Q POWER REF2. For more information, see <i>IGBT Supply Control Program 7.x Firmware Manual</i> [3AFE68315735 (English)].</p> <p>Example 1: When parameter 24.03 Q POWER REF2 SEL is set to PERCENT, value 10000 of parameter 24.02 Q POWER REF2 equals to value 100% of parameter 24.01 Q POWER REF (i.e. 100% of the converter nominal power given in signal 04.06 CONV NOM POWER).</p> <p>Example 2: When parameter 24.03 Q POWER REF2 SEL is set to kVAr, value 1000 of parameter 24.02 Q POWER REF2 equals to parameter 24.01 Q POWER REF value calculated with the following equation: $100 \cdot (1000 \text{ kVAr divided by converter nominal power in kVAr})\%$.</p> <p>Example 3: When parameter 24.03 Q POWER REF2 SEL is set to PHI, value 3000 of parameter 24.02 POWER REF2 equals approximately to parameter 24.01 Q POWER REF value calculated with the following equation:</p> $\cos(30) = \frac{P}{S} = \frac{P}{\sqrt{P^2 + Q^2}}$  <p>Positive reference 30° denotes capacitive load. Negative reference 30° denotes inductive load. P = signal 01.09 POWER value</p> <p>Parameter 24.03 values are converter to degrees by the line-side converter application program: -3000...30000 $\hat{=}$ -30°...30°. Value -10000/10000 equals to -30°/30°, since the range is limited to -3000/3000.</p>	
	-10000...10000	Reference value.	1 = 1
95.07	LCU DC REF	Defines the intermediate circuit DC voltage reference for the line-side converter. This reference is written into line-side converter parameter 23.01 DC VOLT REF. For more information, see <i>IGBT Supply Control Program 7.x Firmware Manual</i> [3AFE68315735 (English)].	
	0...1100 V	Voltage.	1 = 1 V
95.08	LCU PAR1 SEL	Selects the line-side converter address from which the actual signal 09.12 LCU ACT SIGNAL 1 is read from.	
	0...9999	Line-side converter parameter index. For more information, see <i>IGBT Supply Control Program 7.x Firmware Manual</i> [3AFE68315735 (English)].	0...9999
95.09	LCU PAR2 SEL	Selects the line-side converter address from which the actual signal 09.13 LCU ACT SIGNAL 2 is read from.	
	0...9999	Line-side converter parameter index. For more information, see <i>IGBT Supply Control Program 7.x Firmware Manual</i> [3AFE68315735 (English)].	0...9999
96 ANALOGUE OUTPUTS		Output signal selection and processing for the analogue extension module (optional). Only visible when the module is installed and activated by parameter. See also parameter group 15 ANALOGUE OUTPUTS .	
96.01	EXT AO1 SEL	Selects the signal connected to analogue output AO1 of the analogue I/O extension module.	
	NOT USED	See parameter 15.01 .	1
	SPEED	See parameter 15.01 .	2

Index	Name/Selection	Description	FbEq
	FREQUENCY	See parameter 15.01.	3
	CURRENT	See parameter 15.01.	4
	TORQUE	See parameter 15.01.	5
	POWER	See parameter 15.01.	6
	DC BUS VOLT	See parameter 15.01.	7
	OUTPUT VOLT	See parameter 15.01.	8
	REFERENCE	See parameter 15.01.	9
	CONTROL DEV	See parameter 15.01.	10
	ACTUAL 1	See parameter 15.01.	11
	ACTUAL 2	See parameter 15.01.	12
	PICON OUTP	See parameter 15.01.	13
	PICON REF	See parameter 15.01.	14
	ACTUAL FUNC	See parameter 15.01.	15
	COMM MODULE	See parameter 15.01.	16
	EXT AO1 PTR	Source selected by parameter 96.11.	17
96.02	INVERT EXT AO1	Activates the inversion of analogue output AO1 of the analogue I/O extension module.	
	NO	Inactive	0
	YES	Active. The analogue signal is at a minimum level when the drive signal indicated is at its maximum and vice versa.	65535
96.03	MINIMUM EXT AO1	<p>Defines the minimum value for the analogue output AO1 of the analogue I/O extension module.</p> <p>Note: Actually, the setting 10 mA or 12 mA does not set the AO1 minimum but fixes 10/12 mA to actual signal value zero.</p> <p>Example: Motor speed is read through the analogue input.</p> <ul style="list-style-type: none"> – The motor nominal speed is 1000 rpm (parameter 99.08). – 96.02 is NO. – 96.05 is 100%. <p>The analogue output value as a function of speed is shown below.</p>	
	0 mA	0 mA	1
	4 mA	4 mA	2
	10 mA	10 mA	3
	12 mA	12 mA	4



Index	Name/Selection	Description	FbEq
96.04	FILTER EXT AO1	Defines the filtering time constant for analogue output AO1 of the analogue I/O extension module. See parameter 15.04 .	
	0.00 ... 10.00 s	Filtering time constant	0 ... 1000
96.05	SCALE EXT AO1	Defines the scaling factor for analogue output AO1 of the analogue I/O extension module. See parameter 15.05 .	
	10 ... 1000%	Scaling factor	100 ... 10000
96.06	EXT AO2 SEL	Selects the signal connected to analogue output AO2 of the analogue I/O extension module.	
	NOT USED	See parameter 15.01 .	1
	SPEED	See parameter 15.01 .	2
	FREQUENCY	See parameter 15.01 .	3
	CURRENT	See parameter 15.01 .	4
	TORQUE	See parameter 15.01 .	5
	POWER	See parameter 15.01 .	6
	DC BUS VOLT	See parameter 15.01 .	7
	OUTPUT VOLT	See parameter 15.01 .	8
	REFERENCE	See parameter 15.01 .	9
	CONTROL DEV	See parameter 15.01 .	10
	ACTUAL 1	See parameter 15.01 .	11
	ACTUAL 2	See parameter 15.01 .	12
	PICON OUTP	See parameter 15.01 .	13
	PICON REF	See parameter 15.01 .	14
	ACTUAL FUNC	See parameter 15.01 .	15
	COMM MODULE	See parameter 15.06 .	16
	EXT AO2 PTR	Source selected by parameter 96.12 .	17
96.07	INVERT EXT AO2	Activates the inversion of analogue output AO2 of the analogue I/O extension module. The analogue signal is at its minimum level when the drive signal indicated is at its maximum and vice versa.	
	NO	Inactive	0
	YES	Active	65535
96.08	MINIMUM EXT AO2	Defines the minimum value for analogue output AO2 of the analogue I/O extension module. See parameter 96.03 .	
	0 mA	0 mA	1
	4 mA	4 mA	2
	10 mA	10 mA	3
	12 mA	12 mA	4
96.09	FILTER EXT AO2	Defines the filtering time constant for analogue output AO2 of the analogue I/O extension module. See parameter 15.04 .	
	0.00 ... 10.00 s	Filtering time constant	0 ... 1000
96.10	SCALE EXT AO2	Defines the scaling factor for analogue output AO2 of the analogue I/O extension module. See parameter 15.05 .	
	10 ... 1000%	Scaling factor	100 ... 10000

Index	Name/Selection	Description	FbEq
96.11	EXT AO1 PTR	Defines the source or constant for value EXT AO1 PTR of parameter 96.01 .	1000 = 1 mA
	-255.255.31 ... +255.255.31 / C.-32768 ... C.32767	Parameter index or a constant value. See Parameter 10.04 for information on the difference.	-
96.12	EXT AO2 PTR	Defines the source or constant for value EXT AO2 PTR of parameter 96.06 .	1000 = 1 mA
	-255.255.31 ... +255.255.31 / C.-32768 ... C.32767	Parameter index or a constant value. See Parameter 10.04 for information on the difference.	-
98 OPTION MODULES		Activation of the option modules. The parameter settings will remain the same even though the application macro is changed (parameter 99.02).	
98.02	COMM. MODULE LINK	Activates the external serial communication and selects the interface. See the chapter Fieldbus control .	
	NO	No communication	1
	FIELDBUS	The drive communicates via CH0 on the RDCO board (optional). See also parameter group 51 COMM MOD DATA .	2
	ADVANT	The drive communicates with an ABB Advant OCS system via CH0 on the RDCO board (optional). See also parameter group 70 DDCS CONTROL .	3
	STD MODBUS	The drive communicates with a Modbus controller via the Modbus Adapter Module (RMBA) in option slot 1 of the drive. See also parameter group 52 STANDARD MODBUS .	4
	CUSTOMISED	The drive communicates via a customer specified link. The control sources are defined by parameters 90.04 and 90.05 .	5
98.03	DI/O EXT MODULE 1	Activates the communication to the digital I/O extension module 1 (optional) and defines the type and connection interface of the module. See parameters 14.04 and 14.05 for selecting the drive states that are indicated through the relay outputs.	
	NO	Inactive	1 or 2
	RDIO-SLOT1	Communication active. Module type: RDIO. Connection interface: Option slot 1 of the drive.	3
	RDIO-SLOT2	Communication active. Module type: RDIO. Connection interface: Option slot 2 of the drive.	4
	RDIO-DDCS	Communication active. Module type: RDIO. Connection interface: Optional I/O module adapter (AIMA) that communicates with the drive through a fibre optic DDCS link. Note: Module node number must be set to 2. For directions, see <i>User's Manual for RDIO Module</i> (Code: 3AFE 64485733 [English]).	5
98.04	DI/O EXT MODULE 2	Activates the communication to the digital I/O extension module 2 (optional) and defines the type and connection interface of the module. See parameters 14.06 and 14.07 for selecting the drive states that are indicated through the relay outputs.	
	NO	Inactive	1 or 2
	RDIO-SLOT1	Communication active. Module type: RDIO. Connection interface: Option slot 1 of the drive.	3
	RDIO-SLOT2	Communication active. Module type: RDIO. Connection interface: Option slot 2 of the drive.	4

Index	Name/Selection	Description	FbEq
	RDIO-DDCS	Communication active. Module type: RDIO. Connection interface: Optional I/O module adapter (AIMA) that communicates with the drive through a fibre optic DDCS link. Note: Module node number must be set to 3. For directions, see <i>User's Manual for RDIO Module</i> (Code: 3AFE 64485733 [English]).	5
98.06	AI/O EXT MODULE	Activates the communication to the analogue I/O extension module (optional), and defines the type and connection interface of the module. Module inputs: Values AI5 and AI6 in the drive application program are connected to module inputs 1 and 2. See parameters 98.08 and 98.09 for the signal type definitions. Module outputs: See parameters 96.01 and 96.06 for selecting the drive signals that are indicated through module outputs 1 and 2.	
	NO	Communication inactive.	1 or 2
	RAIO-SLOT1	Communication active. Module type: RAIO. Connection interface: Option slot 1 of the drive.	3
	RAIO-SLOT2	Communication active. Module type: RAIO. Connection interface: Option slot 2 of the drive.	4
	RAIO-DDCS	Communication active. Module type: RAIO. Connection interface: Optional I/O module adapter (AIMA) that communicates with the drive through a fibre optic DDCS link. Note: Module node number must be set to 5. For directions, see <i>User's Manual for RAIO Module</i> (Code: 3AFE 64484567 [English]).	5
98.07	COMM PROFILE	Defines the profile on which the communication with the fieldbus or another drive is based. Visible only when fieldbus communication is activated by parameter 98.02.	
	ABB DRIVES	ABB Drives communication profile.	0
	CSA2.8/3.0	Communication profile used by application program versions 2.8 and 3.0.	65535
98.08	AI/O EXT AI1 FUNC	Defines the signal type for input 1 of the analogue I/O extension module (AI5 in the drive application program). The setting must match the signal connected to the module. Note: The communication must be activated by parameter 98.06.	
	UNIP AI5	Unipolar.	1
	BIPO AI5	Bipolar.	2
98.09	AI/O EXT AI2 FUNC	Defines the signal type for input 2 of the analogue I/O extension module (AI6 in the drive application program). The setting must match the signal connected to the module. Note: The communication must be activated by parameter 98.06.	
	UNIP AI6	Unipolar.	1
	BIPO AI6	Bipolar.	2
99 START-UP DATA		Language selection. Definition of motor set-up data.	
99.01	LANGUAGE	Selects the display language. Note: Not all listed languages are necessarily supported.	
	ENGLISH	International English.	0
	ENGLISH AM	American English. If selected, the unit of power used is HP instead of kW.	1
	DEUTSCH	German.	2
	ITALIANO	Italian.	3

Index	Name/Selection	Description	FbEq
	ESPAÑOL	Spanish.	4
	PORTUGUES	Portuguese.	5
	NEDERLANDS	Dutch.	6
	FRANCAIS	French.	7
	DANSK	Danish.	8
	SUOMI	Finnish.	9
	SVENSKA	Swedish.	10
	CESKY	Czech.	11
	POLSKI	Polish.	12
	PO-RUS	Russian.	13
99.02	APPLICATION MACRO	Selects the application macro. See the chapter Application macros for more information. Note: When you change the default parameter values of a macro, the new settings become valid immediately and stay valid even if the power of the drive is switched off and on. However, backup of the default parameter settings (factory settings) of each standard macro is still available. See parameter 99.03 .	
	MULTIMASTER	Multipump control macro in use.	1
	PFC TRAD	PFC TRAD macro in use.	2
	HAND/AUTO	Hand/Auto macro in use.	3
	LEVEL CTRL	Level control macro in use.	4
	USER 1 LOAD	User 1 macro loaded into use. Before loading, check that the saved parameter settings and the motor model are suitable for the application.	5
	USER 1 SAVE	Save User 1 macro. Stores the current parameter settings and the motor model. Note: There are parameters that are not included in the macros. See parameter 99.03 .	6
	USER 2 LOAD	User 2 macro loaded into use. Before loading, check that the saved parameter settings and the motor model are suitable for the application.	7
	USER 2 SAVE	Save User 2 macro. Stores the current parameter settings and the motor model. Note: There are parameters that are not included in the macros. See parameter 99.03 .	8
99.03	APPLIC RESTORE	Restores the original settings of the active application macro (99.02). - If a standard (i.e. other than a User) macro is active, the parameter values are restored to the default settings (factory settings). Exceptions: parameter settings in parameter group 99 remain unchanged. The motor model remains unchanged. - If User Macro 1 or 2 is active, the parameter values are restored to the last saved values. In addition, the last saved motor model are restored. Exceptions: Settings of parameters 16.05 and 99.02 remain unchanged. Note: The parameter settings and the motor model are restored according to the same principles when a macro is changed to another.	
	NO	No action.	0
	YES	Restore original settings.	65535
99.04	MOTOR CTRL MODE	Selects the motor control mode.	
	DTC	Direct Torque Control. This mode is suitable for most applications.	0

Index	Name/Selection	Description	FbEq
	SCALAR	<p>Scalar control. Use scalar control only in those special cases where DTC cannot be used. Scalar control mode is recommended</p> <ul style="list-style-type: none"> - for multimotor drives with variable number of motors - when the nominal current of the motor is less than 1/6 of the nominal output current of the drive (inverter) - the drive is used for test purposes with no motor connected. <p>Note: The outstanding motor control accuracy of the DTC cannot be achieved in scalar control. The differences between the scalar and DTC control modes are pointed out in this manual in relevant parameter lists. Some standard features are disabled in scalar control mode: Motor Identification Run (group 99 START-UP DATA), Speed Limits (group 20 LIMITS), Torque Limit (group 20 LIMITS), DC Hold (group 21 START/STOP), DC Magnetizing (group 21 START/STOP), Speed Controller Tuning (group 23 SPEED CTRL), Flux Optimization (group 26 MOTOR CONTROL), Flux Braking (group 26 MOTOR CONTROL), Underload Function (group 30 FAULT FUNCTIONS), Motor Phase Loss Protection (group 30 FAULT FUNCTIONS), Motor Stall Protection (group 30 FAULT FUNCTIONS).</p>	65535
99.05	MOTOR NOM VOLTAGE	Defines the nominal motor voltage. Must be equal to the value on the motor rating plate.	
	$1/2 \dots 2 \cdot U_N$	<p>Voltage. Allowed range is $1/2 \dots 2 \cdot U_N$ of the drive.</p> <p>Note: The stress on the motor insulations is always dependent on the drive supply voltage. This also applies to the case where the motor voltage rating is lower than the rating of the drive and the supply of the drive.</p>	1 = 1 V
99.06	MOTOR NOM CURRENT	Defines the nominal motor current. Must be equal to the value on the motor rating plate.	
	$0 \dots 2 \cdot I_{2hd}$	<p>Allowed range: approx. $1/6 \dots 2 \cdot I_{2hd}$ of ACS800 (parameter 99.04 = DTC). Allowed range: approx. $0 \dots 2 \cdot I_{2hd}$ of ACS800 (parameter 99.04 = SCALAR).</p>	1 = 0.1 A
99.07	MOTOR NOM FREQ	Defines the nominal motor frequency.	
	8 ... 300 Hz	Nominal frequency (50 or 60 Hz typically)	800 ... 30000
99.08	MOTOR NOM SPEED	Defines the nominal motor speed. Must be equal to the value on the motor rating plate. The motor synchronous speed or another approximate value must not be given instead!	
	1 ... 18000 rpm	Nominal motor speed	1 ... 18000
99.09	MOTOR NOM POWER	Defines the nominal motor power. Set exactly as on the motor rating plate.	
	0 ... 9000 kW	Nominal motor power	0 ... 90000
99.10	MOTOR ID RUN	<p>Selects the type of the motor identification. During the identification, the drive will identify the characteristics of the motor for optimum motor control. The ID Run Procedure is described in the chapter Start-up; and control through the I/O.</p> <p>Note: The ID Run (STANDARD or REDUCED) should be selected if:</p> <ul style="list-style-type: none"> - The operation point is near zero speed, and/or - Operation at torque range above the motor nominal torque within a wide speed range and without any measured speed feedback is required. <p>Note: The ID Run (STANDARD or REDUCED) cannot be performed if parameter 99.04 = SCALAR.</p>	

Index	Name/Selection	Description	FbEq
	NO	No ID Run. The motor model is calculated at first start by magnetising the motor for 20 to 60 s at zero speed. This can be selected in most applications.	1
	STANDARD	<p>Standard ID Run. Guarantees the best possible control accuracy. The ID Run takes about one minute.</p> <p>Note: The motor must be de-coupled from the driven equipment.</p> <p>Note: Check the direction of rotation of the motor before starting the ID Run. During the run, the motor will rotate in the forward direction.</p> <p> WARNING! The motor will run at up to approximately 50 ... 80% of the nominal speed during the ID Run. ENSURE THAT IT IS SAFE TO RUN THE MOTOR BEFORE PERFORMING THE ID RUN!</p>	2
	REDUCED	<p>Reduced ID Run. Should be selected instead of the Standard ID Run:</p> <ul style="list-style-type: none"> - if mechanical losses are higher than 20% (i.e. the motor cannot be de-coupled from the driven equipment) - if flux reduction is not allowed while the motor is running (i.e. in case of a motor with an integrated brake supplied from the motor terminals). <p>Note: Check the direction of rotation of the motor before starting the ID Run. During the run, the motor will rotate in the forward direction.</p> <p> WARNING! The motor will run at up to approximately 50 ... 80% of the nominal speed during the ID Run. ENSURE THAT IT IS SAFE TO RUN THE MOTOR BEFORE PERFORMING THE ID RUN!</p>	3
99.11	DEVICE NAME	Defines the name for the drive or application. The name is visible on the control panel display in the Drive Selection Mode. Note: The name can be edited only by using a drive PC tool (e.g. DriveWindow®).	

Fault tracing

Chapter overview

The chapter lists all warning and fault messages including the possible cause and corrective actions.

Safety



WARNING! Only qualified electricians are allowed to maintain the drive. The *Safety Instructions* on the first pages of the appropriate hardware manual must be read before you start working with the drive.

Warning and fault indications

A warning or fault message on the panel display indicates abnormal drive status. Most warning and fault causes can be identified and corrected using this information. If not, an ABB representative should be contacted.

If the drive is operated with the control panel detached, the red LED in the panel mounting platform indicates the fault condition. (Note: Some drive types are not fitted with the LEDs as standard.)

The four digit code number in brackets after the message is for the fieldbus communication (see the chapter *Fieldbus control*).

How to reset

The drive can be reset either by pressing the keypad **RESET** key, by digital input or fieldbus, or switching the supply voltage off for a while. When the fault has been removed, the motor can be restarted.

Fault history

When a fault is detected, it is stored in the Fault History. The latest faults and warnings are stored together with the time stamp at which the event was detected. See the chapter *Control panel* for more information.

Warning messages generated by the drive

WARNING	CAUSE	WHAT TO DO
ACS 800 TEMP (4210)	The drive temperature is excessive. A warning is given if the inverter module temperature exceeds 115 °C.	Check ambient conditions. Check air flow and fan operation. Check heatsink fins for dust pick-up. Check motor power against unit power.
AI < MIN FUNC (8110) (programmable Fault Function 30.01)	An analogue control signal is below minimum allowed value. This can be caused by incorrect signal level or a failure in the control wiring.	Check for proper analogue control signal levels. Check the control wiring. Check Fault Function parameters.
AUTOCHANGE	The autochange function is being performed.	Refer to the description of parameters 42.06 and 42.07.
BACKUP USED	A PC-stored backup of drive parameters is downloaded into use.	Wait until download is completed.
CALIBRA REQ	Calibration of output current transformers required. Displayed at start if drive is in scalar control (parameter 99.04) and scalar flystart feature is on (parameter 21.08).	Calibration starts automatically. Wait for a while.
CALIBRA DONE	Calibration of output current transformers completed.	Continue normal operation.
CHOKO OTEMP (ff82)	Excessive temperature of drive output filter. Supervision is in use in step-up drives.	Stop drive. Let it cool down. Check ambient temperature. Check filter fan rotates in correct direction and air flows freely.
COMM MODULE (7510) (programmable Fault Function)	Cyclical communication between the drive and the master is lost.	Check the status of fieldbus communication. See the chapter <i>Fieldbus control</i> , or appropriate fieldbus adapter manual. Check parameter settings: - group 51 (for fieldbus adapter) - group 52 (for Standard Modbus Link) Check cable connections. Check if the bus master is not configured, or does not send/receive messages.
EARTH FAULT (2330) (programmable Fault Function 30.17)	The load on the incoming mains system is out of balance. This can be caused by a fault in the motor, motor cable, or an internal malfunction.	Check motor. Check motor cable. Check there are no power factor correction capacitors or surge absorbers in the motor cable.
F TO MS CM LOSS (programmable Fault Function 60.18)	In a Multipump configuration, the master does not receive messages from a follower.	Check fibre optic cabling between the drives on the Multipump link. If the drives are connected in a ring, check that all drives are powered.
ID DONE	The drive has performed the motor identification magnetisation and is ready for operation. This warning belongs to the normal start-up procedure.	Continue drive operation.

WARNING	CAUSE	WHAT TO DO
ID MAGN	Motor identification magnetisation is on. This warning belongs to the normal start-up procedure.	Wait until the drive indicates that motor identification is completed.
ID MAGN REQ	Motor identification is required. This warning belongs to the normal start-up procedure. The drive expects the user to select how the motor identification should be performed: By Identification Magnetisation or by ID Run.	Start the Identification Magnetisation by pressing the Start key, or select the ID Run and start (see parameter 99.10).
ID N CHANGED	The ID number of the drive has been changed from 1.	Change the ID number back to 1. See the chapter <i>Control panel</i> .
ID RUN SEL	Motor Identification Run is selected, and the drive is ready to start the ID Run. This warning belongs to the ID Run procedure.	Press Start key to start the Identification Run.
INLET LOW INLET VERY LOW (programmable Fault Function 44.01 ... 44.06)	Pressure at pump/fan inlet too low.	Check for a closed valve on the inlet side of the pump/fan. Check piping for leaks.
MACRO CHANGE	Macro is restoring or User macro is being saved.	Wait until the drive has finished the task.
MOTOR STALL (7121) (programmable Fault Function 30.10)	The motor is operating in the stall region. This can be caused by excessive load or insufficient motor power.	Check motor load and the ratings of the drive. Check Fault Function parameters.
MOTOR STARTS	Motor Identification Run starts. This warning belongs to the ID Run procedure.	Wait until the drive indicates that motor identification is completed.
MOTOR TEMP (4310) (programmable Fault Function 30.04 ... 30.09)	The motor temperature is excessive. This can be caused by excessive load, insufficient motor power, inadequate cooling or incorrect start-up data.	Check motor ratings, load and cooling. Check start-up data. Check Fault Function parameters.
MS INV LOSS (programmable Fault Function 60.17)	The drive cannot detect a master on a Multipump link, and is not itself allowed to become master.	Check fibre optic cabling between the drives on the Multipump link. Check that a sufficient number of drives are allowed to become master on the link.
OUTLET HIGH OUTLET VERY HIGH (programmable Fault Function 44.08 ... 44.14)	Pressure at pump/fan outlet too high.	Check piping for blocks.

WARNING	CAUSE	WHAT TO DO
PANEL LOSS (5300) (programmable Fault Function 30.02)	A control panel selected as the active control location for the drive has ceased communicating.	Check the panel connection (see the hardware manual). Check control panel connector. Replace control panel in the mounting platform. Check Fault Function parameters.
REPLACE FAN	Running time of the inverter cooling fan has exceeded its estimated lifespan.	Change the fan. Reset fan run time counter 01.44 .
RUN DISABLE	No Run enable signal received.	Check the setting of parameter 16.01 . Switch on the signal or check the wiring of the selected source.
SLEEP MODE	The sleep function has entered the sleeping mode.	Refer to the description of parameter group 43.
START INTERLOCK	No Start Interlock signal received.	Check the circuit connected to the Start Interlock input on the RMIO board.
SYNCRO SPEED	The value of the motor nominal speed set to parameter 99.08 is not correct: The value is too near the synchronous speed of the motor. Tolerance is 0.1%.	Check nominal speed from motor rating plate and set parameter 99.08 exactly accordingly.
THERMISTOR (4311) (programmable Fault Function 30.04 ... 30.05)	The motor temperature is excessive. Motor thermal protection mode selection is THERMISTOR.	Check motor ratings and load. Check start-up data. Check thermistor connections to digital input DI6.
T MEAS ALM	Motor temperature measurement is out of the acceptable range.	Check connections of the motor temperature measurement circuit.
UNDERLOAD (ff6a) (programmable Fault Function 30.13)	Motor load is too low. This can be caused by a release mechanism in the driven equipment.	Check for a problem in the driven equipment. Check Fault Function parameters.

Warning messages generated by the control panel

WARNING	CAUSE	WHAT TO DO
DOWNLOADING FAILED	Download function of the panel has failed. No data has been copied from panel to drive.	Make sure the panel is in local mode. Retry (there might be interference on the link). Contact ABB representative.
DRIVE INCOMPATIBLE DOWNLOADING NOT POSSIBLE	Program versions in the panel and drive do not match. It is not possible to copy data from panel to the drive.	Check program versions (see parameter group 33 INFORMATION).
DRIVE IS RUNNING DOWNLOADING NOT POSSIBLE	Downloading is not possible while the motor is running.	Stop motor. Perform downloading.
NO COMMUNICATION (X)	Cabling problem or a hardware malfunction on the Panel Link.	Check Panel Link connections. Press RESET key. The panel reset may take up to half a minute, please wait.
	(4) = Panel type not compatible with version of the drive application program.	Check panel type and version of the drive application program. The panel type is printed on the cover of the panel. The application program version is stored in parameter 33.02 .
NO FREE ID NUMBERS ID NUMBER SETTING NOT POSSIBLE	The Panel Link already includes 31 stations.	Disconnect another station from the link to free an ID number.
NOT UPLOADED DOWNLOADING NOT POSSIBLE	No upload function has been performed.	Perform the upload function before downloading. See the chapter Control panel .
UPLOADING FAILED	Upload function of the panel has failed. No data has been copied from the drive to the panel.	Retry (there might be interference on the link). Contact ABB representative.
WRITE ACCESS DENIED PARAMETER SETTING NOT POSSIBLE	Certain parameters do not allow changes while motor is running. If tried, no change is accepted, and a warning is displayed.	Stop motor, then change parameter value.
	Parameter lock is on.	Open the parameter lock (see parameter 16.02).

Fault messages generated by the drive

FAULT	CAUSE	WHAT TO DO
ACS 800 TEMP (4210)	Excessive internal temperature. Trip level of inverter module temperature is 125 °C.	Check ambient conditions. Check air flow and fan operation. Check heatsink fins for dust pick-up. Check motor power against unit power.
AI < MIN FUNC (8110) (programmable Fault Function 30.01)	Analogue control signal is below minimum allowed value due to incorrect signal level or failure in the control wiring.	Check for proper analogue control signal levels. Check control wiring. Check Fault Function parameters.
BACKUP ERROR	Failure when restoring PC-stored backup of drive parameters.	Retry. Check connections. Check that parameters are compatible with drive.
CTRL B TEMP (4110)	Control board temperature is lower than -5 ... 0 °C or exceeds +73 ... 82 °C.	Check air flow and fan operation.
BR BROKEN (7111)	Brake resistor is not connected or it is damaged. The resistance rating of the brake resistor is too high.	Check the resistor and the resistor connection. Check that the resistance rating meets the specification.
BC SHORT CIR (7113)	Short circuit in brake chopper IGBT(s).	Replace brake chopper. Ensure brake resistor is connected and not damaged.
BR WIRING (7111)	Wrong connection of brake resistor.	Check resistor connection. Ensure brake resistor is not damaged.
COMM MODULE (7510) (programmable Fault Function)	Cyclical communication with drive and master station is lost.	Check status of fieldbus communication. See the chapter <i>Fieldbus control</i> , or appropriate fieldbus adapter manual. Check parameter settings: - group 51 (for fieldbus adapter), or - group 52 (for Standard Modbus Link) Check cable connections. Check if master can communicate.
CURR MEAS (2211)	Current transformer failure in output current measurement circuit.	Check current transformer connections to Main Circuit Interface Board, INT.
DC HIGH RUSH (FF80)	Drive supply voltage is excessive. When supply voltage is over 124% of the voltage rating of the unit (415, 500 or 690 V), motor speed rushes to trip level (40% of the nominal speed).	Check supply voltage level, rated voltage of the drive and allowed voltage range of the drive.

FAULT	CAUSE	WHAT TO DO
DC OVERVOLT (3210)	Excessive intermediate circuit DC voltage. DC overvoltage trip limit is $1.3 \cdot U_{1max}$, where U_{1max} is the maximum value of the mains voltage range. For 400 V units, U_{1max} is 415 V. For 500 V units, U_{1max} is 500 V. Actual voltage in the intermediate circuit corresponding to the mains voltage trip level is 728 VDC for 400 V units and 877 VDC for 500 V units.	Check that the overvoltage controller is on (Parameter 20.05). Check mains for static or transient overvoltage. Check brake chopper and resistor (if used). Check deceleration time. Use coast-to-stop function (if applicable). Retrofit the frequency converter with a brake chopper and a brake resistor.
DC UNDERVOLT (3220)	Intermediate circuit DC voltage is not sufficient due to missing mains phase, a blown fuse or a rectifier bridge internal fault. DC undervoltage trip limit is $0.65 \cdot U_{1min}$, where U_{1min} is the minimum value of the mains voltage range. For 400 V and 500 V units, U_{1min} is 380 V. Actual voltage in the intermediate circuit corresponding to the mains voltage trip level is 334 VDC	Check mains supply and fuses.
EARTH FAULT (2330) (programmable Fault Function 30.17)	Load on the incoming mains system is out of balance due to fault in the motor, motor cable or an internal malfunction.	Check motor. Check motor cable. Check there are no power factor correction capacitors or surge absorbers in the motor cable.
EXTERNAL FLT (9000) (programmable Fault Function 30.03)	Fault in one of the external devices. (This information is configured through one of the programmable digital inputs.)	Check external devices for faults. Check parameter 30.03 EXTERNAL FAULT.
FAN OVERTEMP (ff83)	Excessive temperature of drive output filter fan. Supervision is in use in step-up drives.	Stop drive. Let it cool down. Check ambient temperature. Check fan rotates in correct direction and air flows freely.
ID RUN FAIL	Motor ID Run is not completed successfully.	Check maximum speed (Parameter 20.02). It should be at least 80% of the nominal speed of the motor (Parameter 99.08).
IN CHOKE TEMP (ff81)	Excessive input choke temperature.	Stop drive. Let it cool down. Check ambient temperature. Check that fan rotates in correct direction and air flows freely.
INLET LOW INLET VERY LOW (programmable Fault Function 44.01 ... 44.06)	Pressure at pump/fan inlet too low.	Check for a closed valve on the inlet side of the pump/fan. Check piping for leaks.

FAULT	CAUSE	WHAT TO DO
I/O COMM ERR (7000)	Communication error on the control board, channel CH1. Electromagnetic interference.	Check connections of fibre optic cables on channel CH1. Check all I/O modules (if present) connected to channel CH1. Check for proper earthing of the equipment. Check for highly emissive components nearby.
LINE CONV (ff51)	Fault on the line side converter.	Shift panel from motor-side converter control board to line-side converter control board. See line side converter manual for fault description.
MOTOR PHASE (ff56) (programmable Fault Function 30.16)	One of the motor phases is lost due to fault in the motor, motor cable, thermal relay (if used) or internal fault.	Check motor and motor cable. Check thermal relay (if used). Check Fault Function parameters. Disable this protection.
MOTOR TEMP (4310) (programmable Fault Function 30.04 ... 30.09)	Motor temperature is too high (or appears to be too high) due to excessive load, insufficient motor power, inadequate cooling or incorrect start-up data.	Check motor ratings and load. Check start-up data. Check Fault Function parameters.
MOTOR STALL (7121) (programmable Fault Function 30.10 ... 30.12)	Motor is operating in the stall region due to e.g. excessive load or insufficient motor power.	Check motor load and the drive ratings. Check Fault Function parameters.
MS INV LOSS (programmable Fault Function 60.17)	The drive cannot detect a master on a Multipump link, and is not itself allowed to become master.	Check fibre optic cabling between the drives on the Multipump link. If the drives are connected in a ring, check that all drives are powered. Check that a sufficient number of drives are allowed to become master on the link.
NO MOT DATA (ff52)	Motor data is not given or motor data does not match with inverter data.	Check motor data given by parameters 99.04 ... 99.09.
OUTLET HIGH OUTLET VERY HIGH (programmable Fault Function 44.08 ... 44.14)	Pressure at pump/fan outlet too high.	Check piping for blocks.
OVERCURRENT (2310)	Output current is excessive. Overcurrent trip limit is $1.65 \dots 3.5 \cdot I_{\max}$ depending on drive type.	Check motor load. Check acceleration time. Check motor and motor cable (including phasing). Check there are no power factor correction capacitors or surge absorbers in the motor cable. Check encoder cable (including phasing).

FAULT	CAUSE	WHAT TO DO
OVERFREQ (7123)	<p>Motor is turning faster than the highest allowed speed due to incorrectly set minimum/maximum speed, insufficient braking torque or changes in the load when using torque reference.</p> <p>Trip level is 40 Hz over the operating range absolute maximum speed limit (Direct Torque Control mode active) or frequency limit (Scalar Control active). The operating range limits are set by parameters 20.01 and 20.02 (DTC mode active) or 20.07 and 20.08 (Scalar Control active).</p>	<p>Check minimum/maximum speed settings.</p> <p>Check adequacy of motor braking torque.</p> <p>Check applicability of torque control.</p> <p>Check need for a brake chopper and resistor(s).</p>
PANEL LOSS (5300) (programmable Fault Function 30.02)	A control panel or DriveWindow [®] selected as active control location for the drive has ceased communicating.	<p>Check panel connection (see appropriate hardware manual).</p> <p>Check control panel connector.</p> <p>Replace control panel in the mounting platform.</p> <p>Check Fault Function parameters.</p> <p>Check DrivesWindow connection.</p>
PPCC LINK (5210)	Fibre optic link to the INT board is faulty.	Check fibre optic cables.
RUN DISABLE	No Run enable signal received.	Check the setting of parameter 16.01 . Switch on the signal or check the wiring of the selected source.
SC (INU 1) SC (INU 2) SC (INU 3) SC (INU 4)	<p>Short circuit in inverter unit of several parallel inverter modules. The number refers to the faulty inverter module number.</p> <p>INT board fibre optic connection fault in inverter unit consisting of several parallel inverter modules. The number refers to the inverter module number.</p>	<p>Check motor and motor cable.</p> <p>Check power semiconductors (IGBT power plates) of inverter module. (INU 1 stands for inverter module 1 etc.).</p> <p>Check connection from inverter module Main Circuit Interface Board, INT to PPCC Branching Unit, PBU. (Inverter module 1 is connected to PBU CH1 etc.)</p>
SHARE IO COMM LOSS	Analogue input data sharing is enabled but no data can be received.	<p>Check the fibre optic cabling between the drives.</p> <p>Check the analogue input signal wiring.</p>
SHORT CIRC (2340)	<p>Short-circuit in the motor cable(s) or motor.</p> <p>Output bridge of the converter unit is faulty.</p>	<p>Check motor and motor cable.</p> <p>Check there are no power factor correction capacitors or surge absorbers in the motor cable.</p> <p>Consult ABB representative.</p>
SLOT OVERLAP	Two option modules have the same connection interface selection.	Check connection interface selections in group 98 OPTION MODULES .
START INHIBIT (ff7a)	Optional start inhibit hardware logic is activated.	Check start inhibit circuit (GPS board).

FAULT	CAUSE	WHAT TO DO
START SEL WRONG	A pulse-type start/stop command is selected for external control location 2 (EXT2) when either the Multipump or Level control macro is active.	Select a non-pulse start/stop source at parameter 10.02 EXT 2 STRT/STP/DI .
SUPPLY PHASE (3130)	Intermediate circuit DC voltage is oscillating due to a missing supply phase, a blown fuse or a rectifier bridge internal fault. A trip occurs when the DC voltage ripple is 13 percent of the DC voltage.	Check mains fuses. Check for mains supply imbalance.
THERMISTOR (4311) (programmable Fault Function 30.04 ... 30.05)	Excessive motor temperature (detected by the motor thermal protection function, which has selection THERMISTOR active) .	Check motor ratings and load. Check start-up data. Check thermistor connections. Check thermistor cabling.
UNDERLOAD (ff6a) (programmable Fault Function 30.13 ... 30.15)	Motor load is too low due to e.g. release mechanism in the driven equipment.	Check for a problem in the driven equipment. Check Fault Function parameters.
USER MACRO	No User Macro saved or the file is defective.	Create User Macro.
THERMAL MODE	Motor thermal protection mode is set to DTC for a high-power motor.	See parameter 30.05 .

Pump control application examples

Overview

This chapter contains the following pump control application examples:

- 2-pump station with 1 drive
- Multipump configuration with 2 (or more) drives
- Level control configuration with 2 (or more) drives
- Pump station remote-controlled through the Internet.

2-pump station with 1 drive

The pumps are used for pressure boosting. Pump alternation and sleep function are used. The application also includes the following additional features:

- Manual control switches for selection between conventional PFC control and direct-on-line connection of the motors (S1, S2). The switches are of the three-position type:
A = PFC control in use.
0 = Motor is off.
H = PFC control is by-passed and motor is connected direct-on-line.
- Drive start inhibit switch (S3).

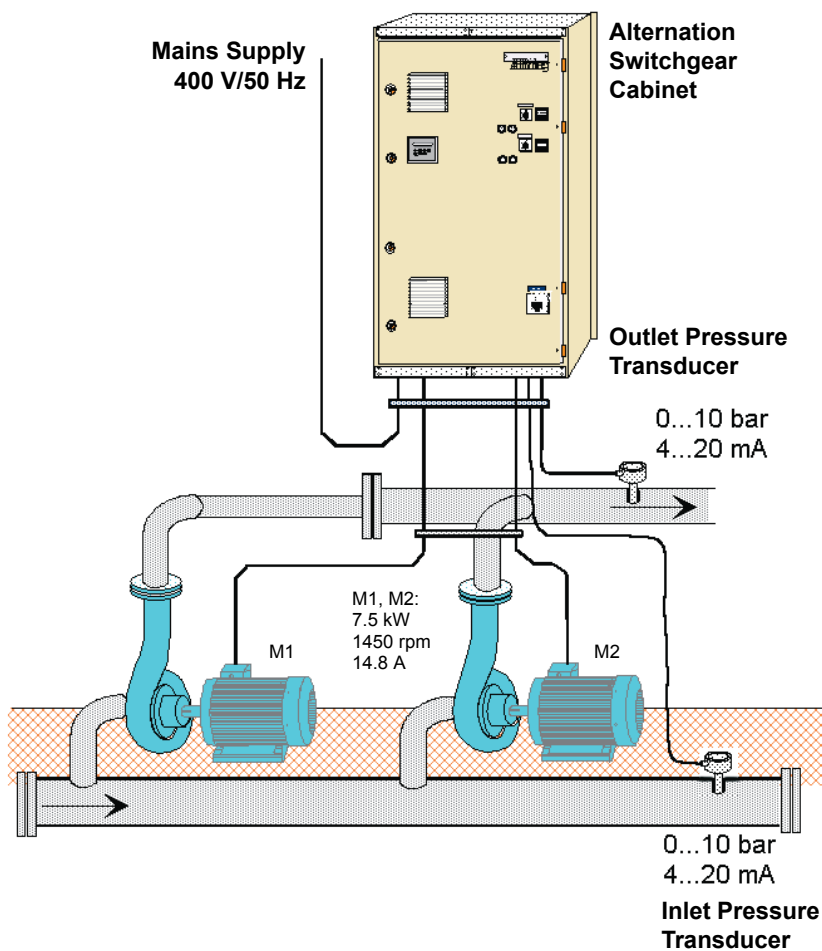

Sheet 1 of 3

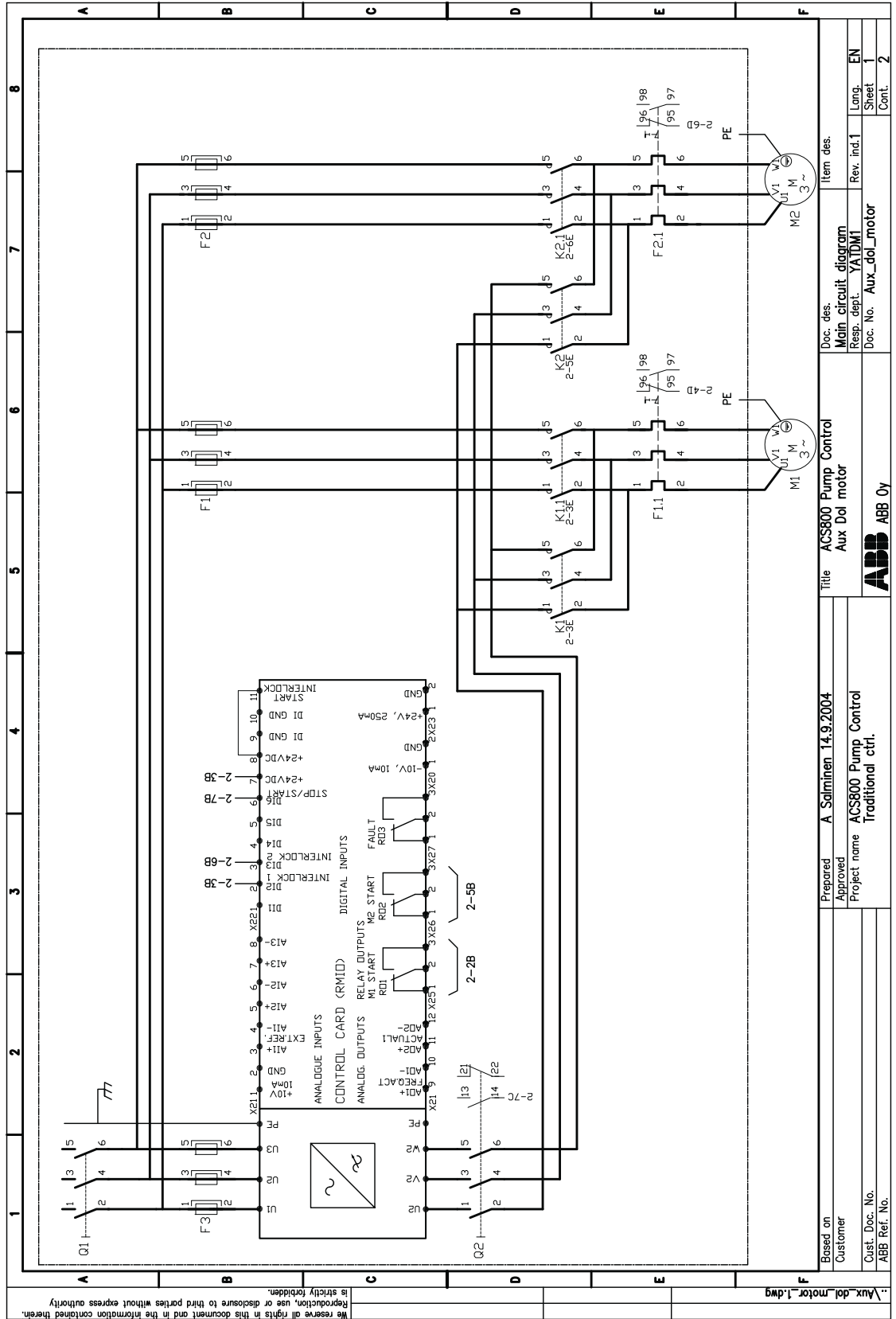

We reserve all rights in this document and in the information contained therein. Reproduction, use or disclosure to third parties without express authority is strictly forbidden.

1: Aux_dol_motor_1.dwg

Based on	Customer	Prepared	A. Salminen 14.9.2004	Title	ACS800 Pump Control	Doc. des.	Item des.
Cust. Doc. No.	ABB Ref. No.	Approved		Project name	Aux Dol motor	Resp. dept.	YADM1
		Project name	Traditional ctrl.			Doc. No.	Aux_dol_motor
				ABB	ABB Oy		
						Rev. ind.1	Rev. ind.1
						Sheet	1
						Cont.	2

Sheet 2 of 3

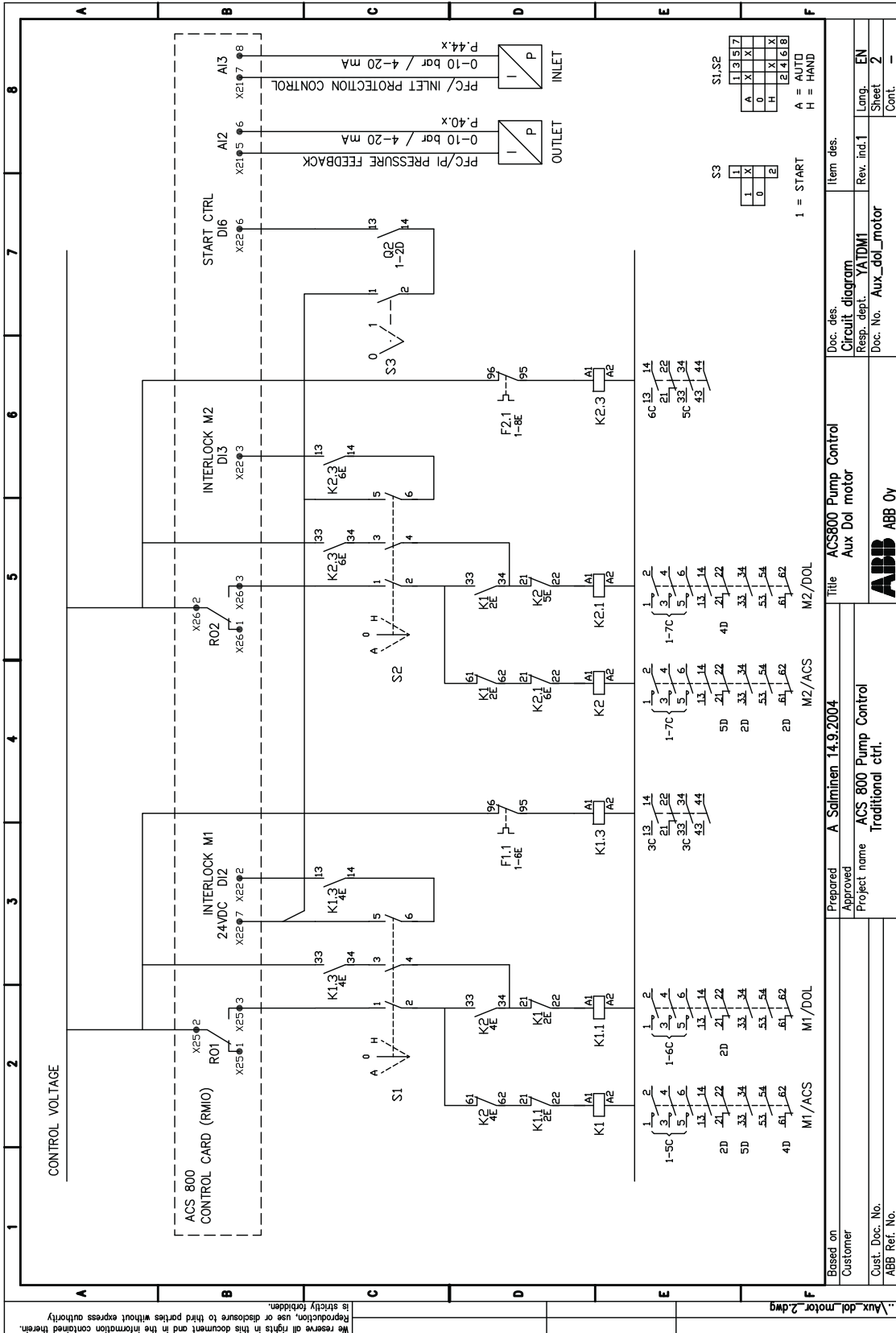

..Aux_dol_motor_2.dwg
 We reserve all rights in this document and in the information contained therein.
 Reproduction, use or disclosure to third parties without express authority
 is strictly forbidden.

Sheet 3 of 3 (Pressure sensor connection examples)

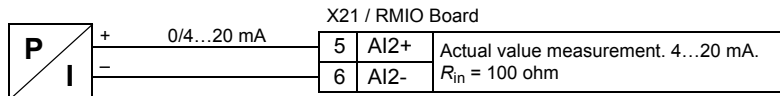

Note: The sensor must be powered externally.

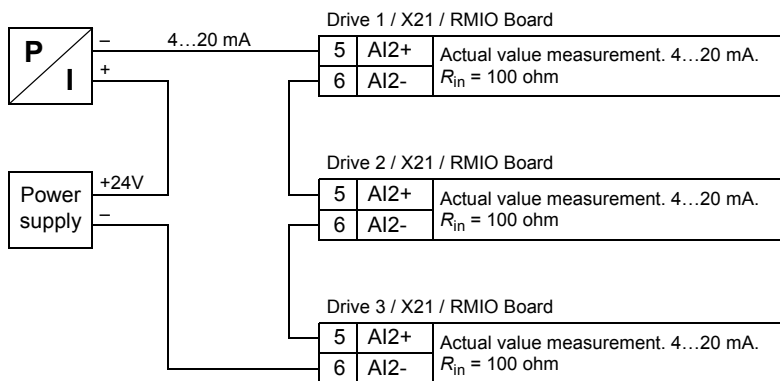
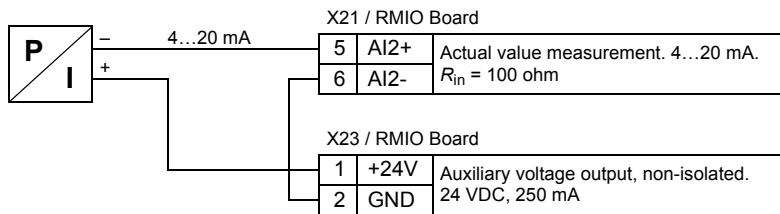
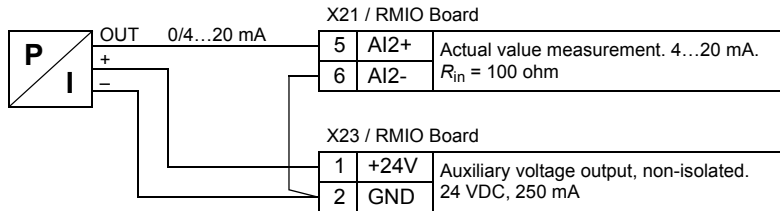

Multipump configuration with 2 (or more) drives

Wiring diagram

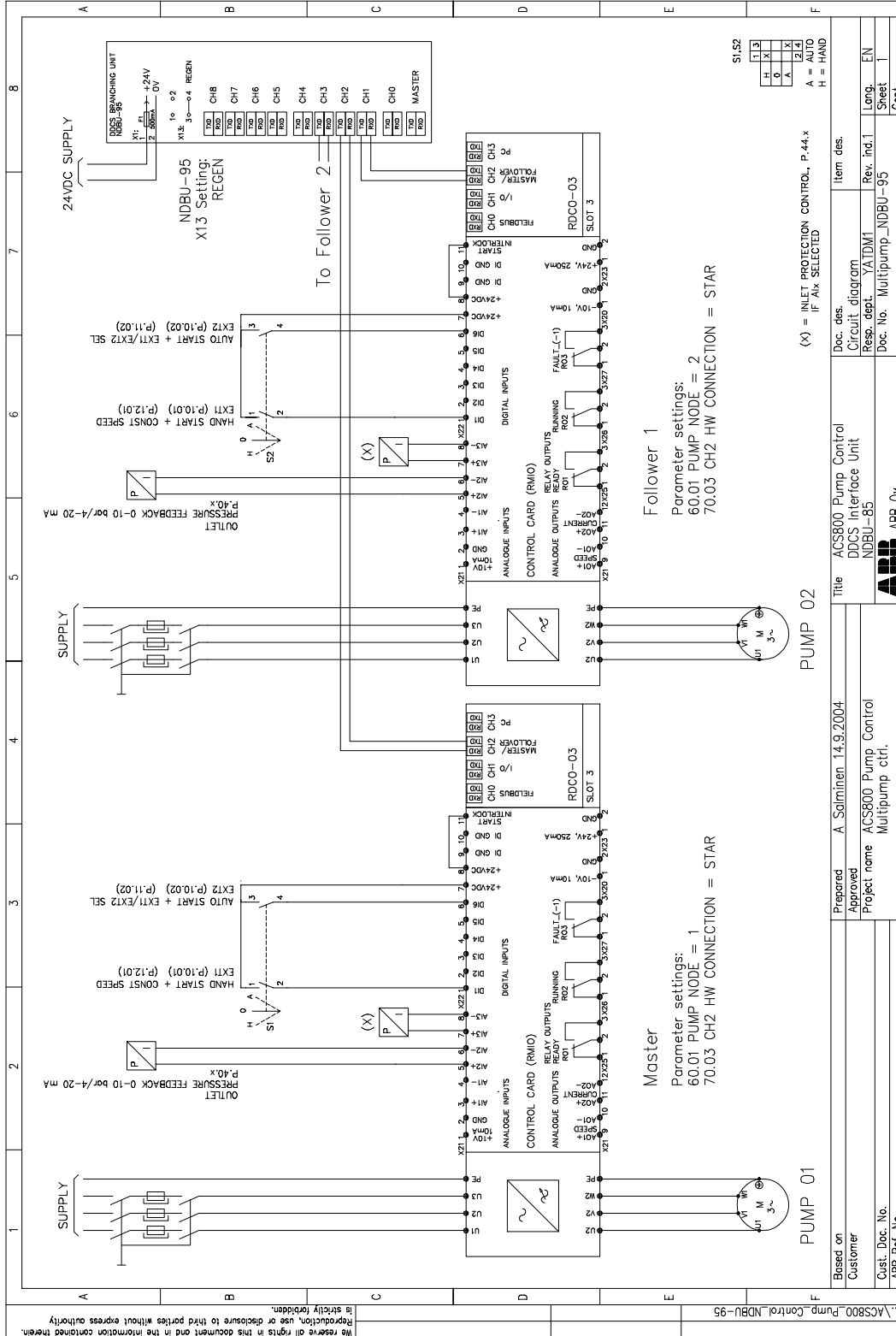

Optical fibre connections

Ring

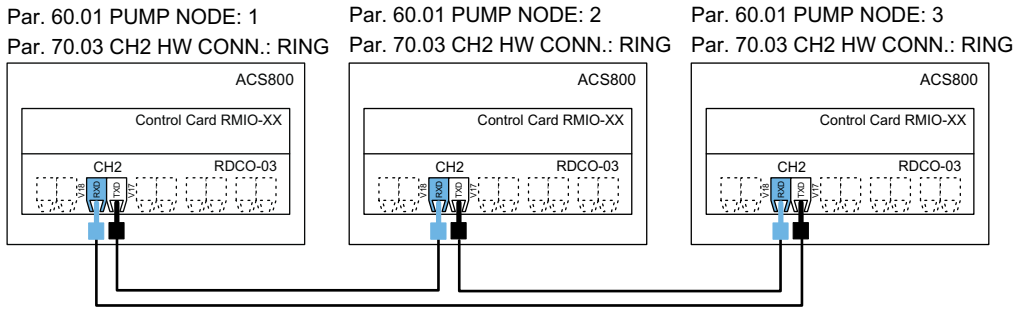

Star

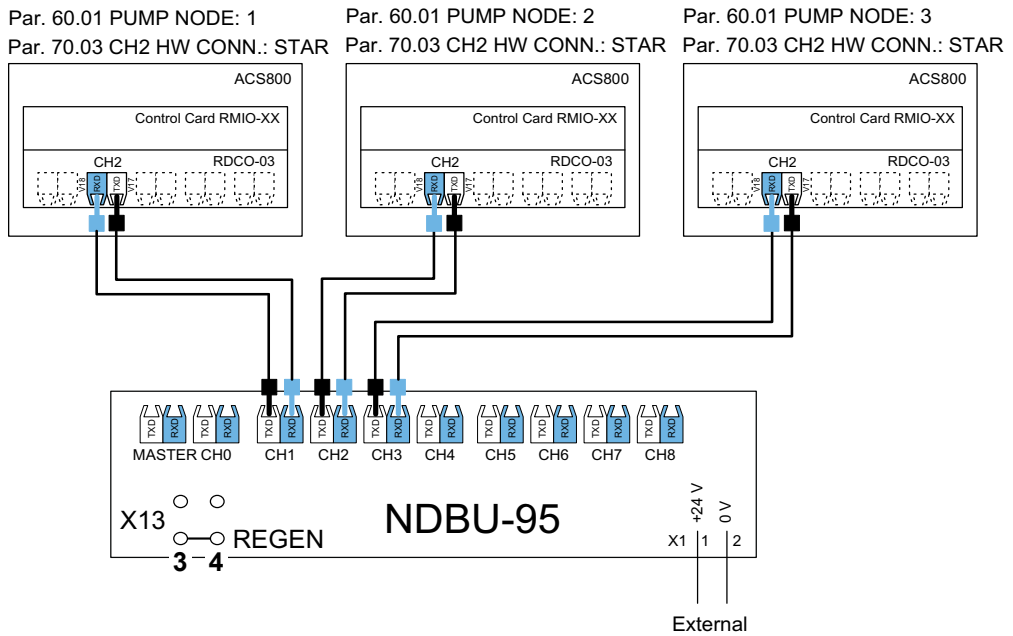

Level control configuration with 2 drives

Wiring diagram

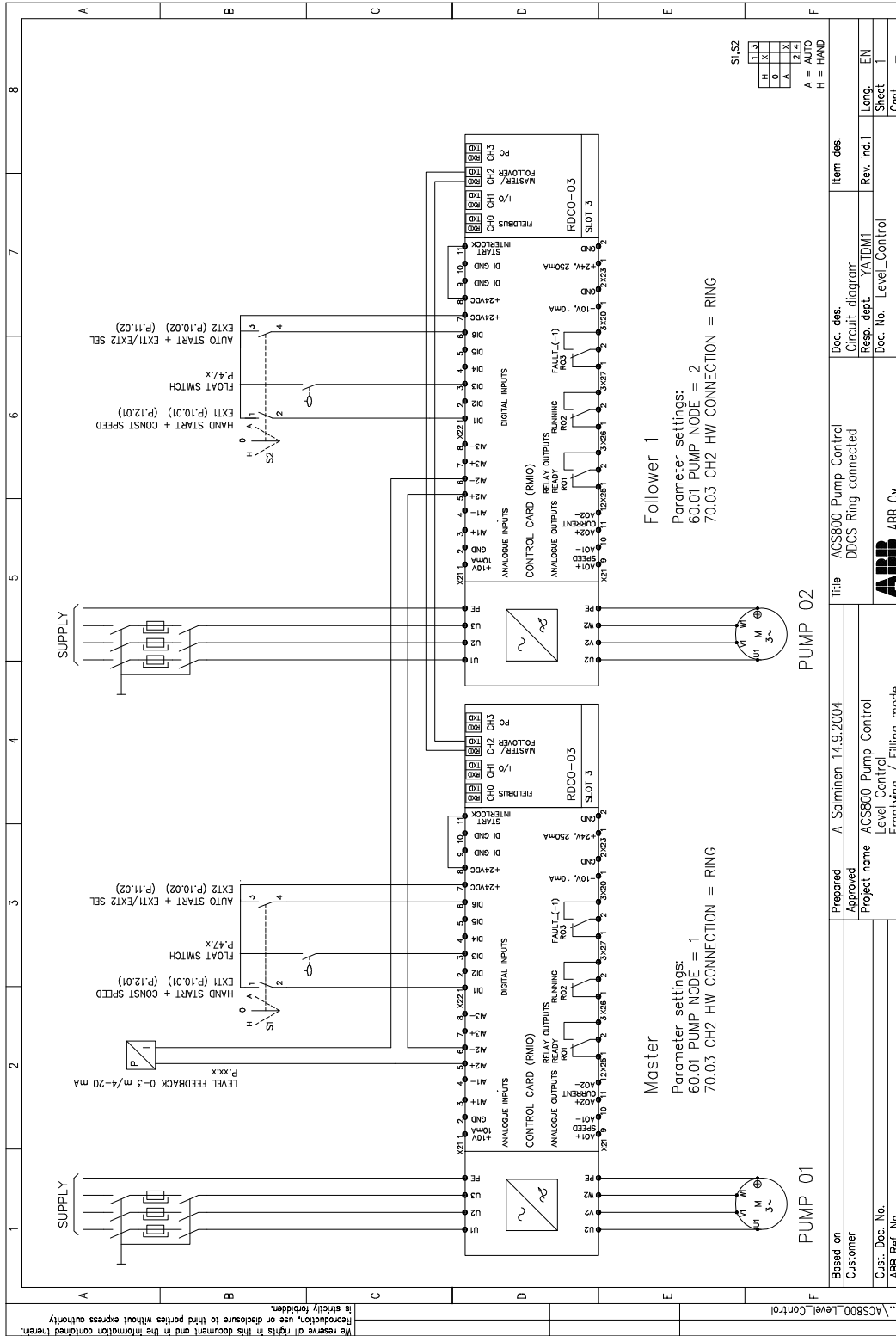

Pump station remote-controlled through the Internet

Pump stations are often located in remote sites and far from supervisory sites. The PSA-01 Server is a device that can be used to control remote stations through the Internet in order to cut maintenance costs. The PSA-01 maintains a database of data and alarms it receives from the monitored stations, and informs service personnel through SMS (Short Message Service) in case something goes wrong with any of the stations.

The PSA-01 has built-in web pages that enable easy system configuration and access to the database. These features can also be used by the local or global ABB support if necessary.

The picture below presents the system architecture. The system components are as follows:

PSA-01 Server

- Web interface for configuring the system and browsing the database
- GSM module for sending SMS messages to service personnel (SIM card required)
- Email system for sending and receiving email messages
- Provision to export database information
- Access to the NETA-01 Ethernet Adapter Module
- Username and password protection for each pump station

NETA-01 Intelligent Ethernet Adapter

- Built-in web pages for parameter adjustment, monitoring, and diagnosing of the drive over the Internet
- Email client for sending predefined emails to the PSA-01 Server
- Modbus TCP interface for control
- Can be used with LAN, WLAN, analogue modem, xDSL and GPRS

Supervisory site

- Standard PC with an Internet browser needed to access the PSA-01 Server and the Java Virtual Machine (free plugin) to use the NETA-01
- Mobile phones for service personnel
- PSA-01 Server that can receive emails from multiple stations

Optional ABB remote support

- Standard PC that can be used to access the PSA-01 Server database, and drive settings via the NETA-01 Ethernet Adapter

Alternatively, Modbus TCP master software or hardware can be used to monitor remote stations. The Modbus TCP master can use the OPC interface for client application to ease integration. This option is also shown in the picture below.

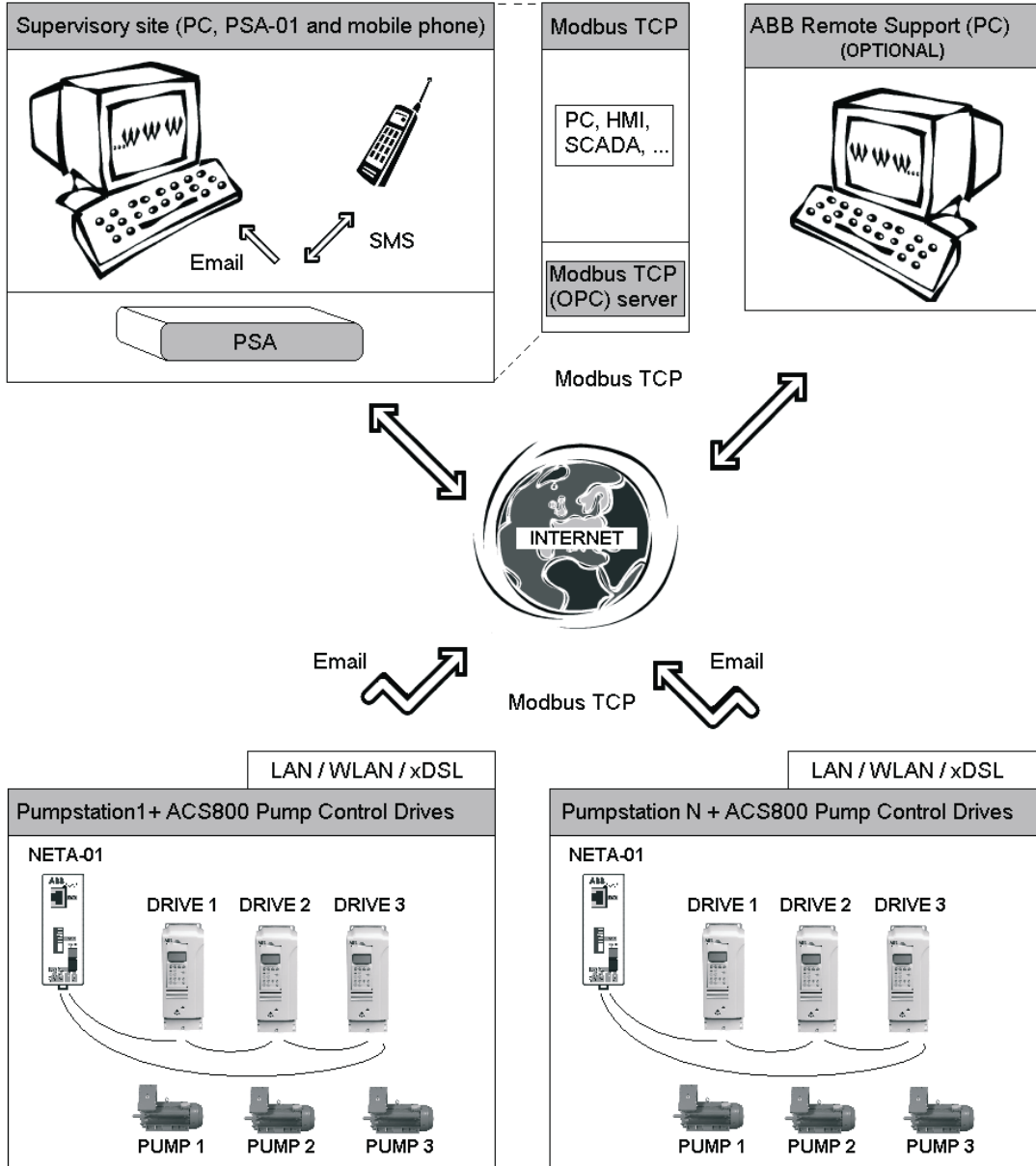

Fieldbus control

Chapter overview

The chapter describes how the drive can be controlled by external devices over a communication network.

System overview

The drive can be connected to an external control system – usually a fieldbus controller – via an adapter module connected to fibre optic cable CH0 on the RDCO communication module (optional). For connection to an Advant Fieldbus 100 system, an external AF 100 interface is used.

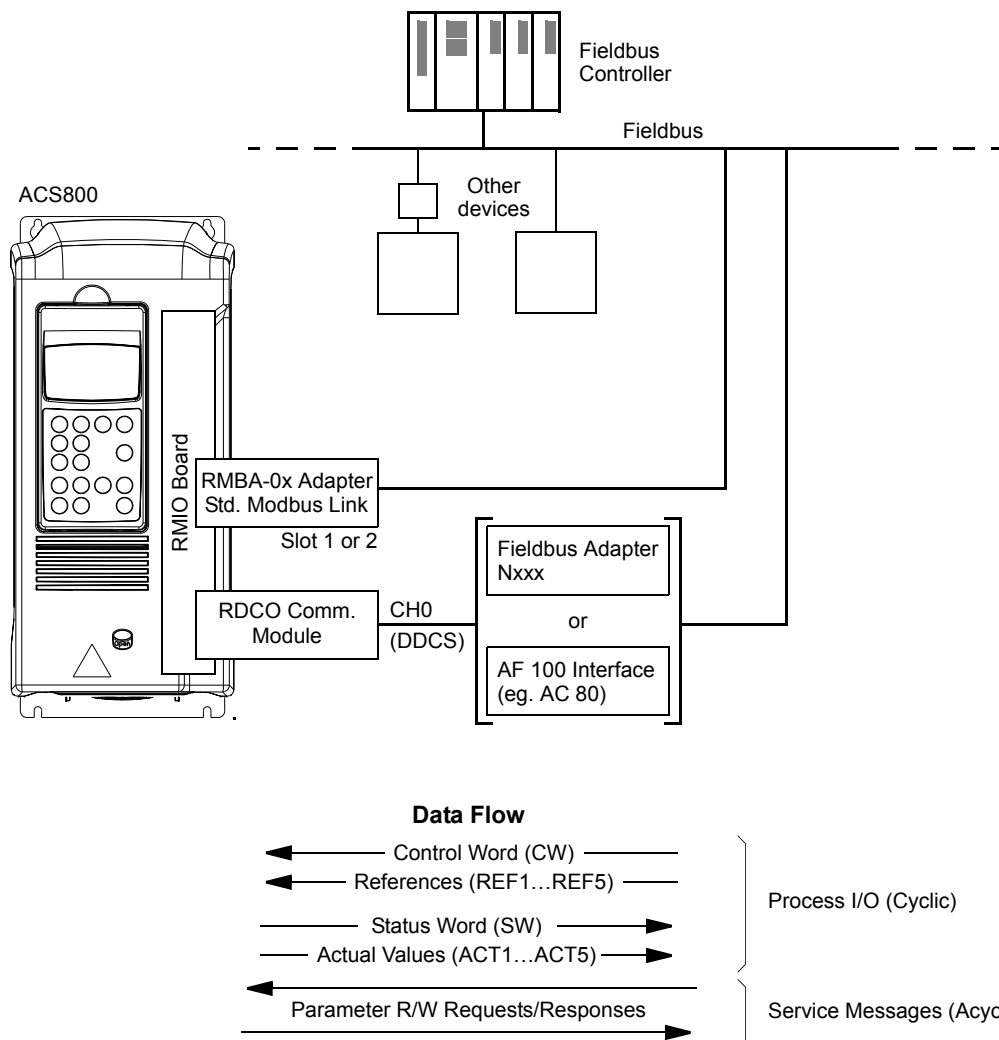

Figure 1 Fieldbus control.

The drive can be set to receive all of its control information through the fieldbus interface, or the control can be distributed between the fieldbus interface and other available sources, e.g. digital and analogue inputs.

Setting up communication through a fieldbus adapter module

Before configuring the drive for fieldbus control, the adapter module must be mechanically and electrically installed according to the instructions given in the *Hardware Manual* of the drive, and the module manual.

The communication between the drive and the fieldbus adapter module is then activated by setting parameter [98.02](#). After the communication is initialised, the configuration parameters of the module become available in the drive at parameter group 51.

Table 1 Communication set-up parameters for fieldbus adapter connection.

Parameter	Alternative settings	Setting for fieldbus control	Function/Information
COMMUNICATION INITIALISATION			
98.02 COMM. MODULE LINK	NO; FIELDBUS; ADVANT; STD MODBUS; CUSTOMISED	FIELDBUS	Initialises communication between drive and fieldbus adapter module. Activates module set-up parameters (Group 51).
98.07 COMM PROFILE	ABB DRIVES; CSA 2.8/3.0	ABB DRIVES	Selects the communication profile used by the drive. See section <i>Communication Profiles</i> below.
ADAPTER MODULE CONFIGURATION			
51.01 MODULE TYPE	–	–	Displays the type of the fieldbus adapter module.
51.02 (FIELDBUS PARAMETER 2)	These parameters are adapter module-specific. For more information, see the module manual. Note that not all of these parameters are necessarily visible.		
•••			
51.26 (FIELDBUS PARAMETER 26)			
51.27 FBA PAR REFRESH*	(0) DONE; (1) REFRESH	–	Validates any changed adapter module configuration parameter settings. After refreshing, the value reverts automatically to DONE.
51.28 FILE CPI FW REV*	xyz (binary coded decimal)	–	Displays the required CPI firmware revision of the fieldbus adapter as defined in the configuration file stored in the memory of the drive. The CPI firmware version of the fieldbus adapter (refer to par. 51.32) must contain the same or a later CPI version to be compatible. x = major revision number; y = minor revision number; z = correction number. Example: 107 = revision 1.07.

Parameter	Alternative settings	Setting for fieldbus control	Function/Information
51.29 FILE CONFIG ID*	xyz (binary coded decimal)	–	Displays the fieldbus adapter module configuration file identification stored in the memory of the drive. This information is drive application program-dependent.
51.30 FILE CONFIG REV*	xyz (binary coded decimal)	–	Displays the fieldbus adapter module configuration file revision stored in the memory of the drive. x = major revision number; y = minor revision number; z = correction number. Example: 1 = revision 0.01.
51.31 FBA STATUS	(0) IDLE; (1) EXEC. INIT; (2) TIME OUT; (3) CONFIG ERROR; (4) OFF-LINE; (5) ON-LINE; (6) RESET	–	Displays the status of the adapter module. IDLE = Adapter not configured. EXEC. INIT = Adapter initialising. TIME OUT = A timeout has occurred in the communication between the adapter and the drive. CONFIG ERROR = Adapter configuration error. The major or minor revision code of the CPI firmware revision stored in the adapter differs from that stated in the configuration file in the memory of the drive. OFF-LINE = Adapter is off-line. ON-LINE = Adapter is on-line. RESET = Adapter performing a hardware reset.
51.32 FBA CPI FW REV	–	–	Displays the CPI program revision of the module inserted in slot 1. x = major revision number; y = minor revision number; z = correction number. Example: 107 = revision 1.07.
51.33 FBA APPL FW REV	–	–	Displays the application program revision of the module inserted in slot 1. x = major revision number; y = minor revision number; z = correction number. Example: 107 = revision 1.07.

*Parameters 51.27 to 51.33 are only visible with a type Rxxx fieldbus adapter installed.

After the parameters in group 51 have been set, the drive control parameters (shown in [Table 4](#)) must be checked and adjusted where necessary.

The new settings will take effect when the drive is next powered up.

Control through the Standard Modbus Link

An RMBA-01 Modbus Adapter installed in slot 1 or 2 of the drive forms an interface called the Standard Modbus Link. The Standard Modbus Link can be used for external control of the drive by a Modbus controller (RTU protocol only).

It is possible to switch the control between the Standard Modbus Link and another fieldbus adapter, in which case the RMBA-01 is installed in slot 2, the fieldbus adapter in slot 1.

Communication set-up

The communication through the Standard Modbus Link is initialised by setting parameter [98.02](#) to STD MODBUS. Then, the communication parameters in group 52 must be adjusted. See the table below.

Table 2 Communication set-up parameters for the Standard Modbus Link.

Parameter	Alternative Settings	Setting for Control through the Standard Modbus Link	Function/Information
COMMUNICATION INITIALISATION			
98.02 COMM. MODULE LINK	NO; FIELDBUS; ADVANT; STD MODBUS; CUSTOMISED	STD MODBUS	Initialises communication between drive (Standard Modbus Link) and Modbus-protocol controller. Activates communication parameters in group 52.
98.07 COMM PROFILE	ABB DRIVES; CSA 2.8/3.0	ABB DRIVES	Selects the communication profile used by the drive. See section <i>Communication Profiles</i> below.
COMMUNICATION PARAMETERS			
52.01 STATION NUMBER	1 to 247	–	Specifies the station number of the drive on the Standard Modbus Link.
52.02 BAUDRATE	600; 1200; 2400; 4800; 9600; 19200	–	Communication speed for the Standard Modbus Link.
52.03 PARITY	ODD; EVEN; NONE1STOPBIT; NONE2STOPBIT	–	Parity setting for the Standard Modbus Link.

After the parameters in group 52 have been set, the drive control parameters (shown in [Table 4](#)) should be checked and adjusted where necessary.

Modbus addressing

In the Modbus controller memory, the Control Word, the Status Word, the references, and the actual values are mapped as follows:

Data from fieldbus controller to drive		Data from drive to fieldbus controller	
Address	Contents	Address	Contents
40001	Control Word	40004	Status Word
40002	Reference 1	40005	Actual 1
40003	Reference 2	40006	Actual 2
40007	Reference 3	40010	Actual 3
40008	Reference 4	40011	Actual 4
40009	Reference 5	40012	Actual 5

More information on Modbus communication is available from the Modicon website <http://www.modicon.com>.

Setting up an Advant Fieldbus 100 (AF 100) connection

The connection of a drive to an AF (Advant Fieldbus) 100 bus is similar to other fieldbusses, with the exception that one of the AF 100 interfaces listed below is substituted for the fieldbus adapter. The AF 100 interface is connected to channel CH0 on the RDCO board inside the drive using fibre optic cables.

The following is a list of suitable AF 100 interfaces:

- **CI810A Fieldbus Communication Interface (FCI)**
TB811 (5 MBd) or TB810 (10 MBd) Optical ModuleBus Port Interface required
- **Advant Controller 70 (AC 70)**
TB811 (5 MBd) or TB810 (10 MBd) Optical ModuleBus Port Interface required
- **Advant Controller 80 (AC 80)**
Optical ModuleBus connection: TB811 (5 MBd) or TB810 (10 MBd) Optical ModuleBus Port Interface required
DriveBus connection: Connectible to RMIO-01/02 Board with RDCO-01 Communication Option.

One of the above interfaces may already be present on the AF 100 bus. If not, an Advant Fieldbus 100 Adapter kit (NAFA-01) is separately available, containing the CI810A Fieldbus Communication Interface, TB810 and TB811 Optical ModuleBus Port Interfaces, and a TC505 Trunk Tap. (More information on these components is available from the *S800 I/O User's Guide*, 3BSE 008 878 [ABB Industrial Systems, Västerås, Sweden]).

Optical component types

The TB811 Optical ModuleBus Port Interface is equipped with 5 MBd optical components, while the TB810 has 10 MBd components. All optical components on a fibre optic link must be of the same type since 5 MBd components do not communicate with 10 MBd components. The choice between TB810 and TB811 depends on the equipment it is connected to.

The TB811 (5 MBd) should be used when connecting to a drive with the following equipment:

- RMIO-01/02 Board with RDCO-02 Communication Option
- RMIO-01/02 Board with RDCO-03 Communication Option.

The TB810 (10 MBd) should be used when connecting to the following equipment:

- RMIO-01/02 Board with RDCO-01 Communication Option
- NDBU-85/95 DDCS Branching Units.

Communication Set-up

The communication between the drive and the AF 100 interface is activated by setting parameter [98.02](#) to ADVANT.

Table 3 Communication set-up parameters for AF 100 connection.

Parameter	Alternative Settings	Setting for Control through CH0	Function/Information
COMMUNICATION INITIALISATION			
98.02 COMM. MODULE LINK	NO; FIELDBUS; ADVANT; STD MODBUS, CUSTOMISED	ADVANT	Initialises communication between drive (fibre optic channel CH0) and AF 100 interface. The transmission speed is 4 Mbit/s.
98.07 COMM PROFILE	ABB DRIVES; CSA 2.8/3.0	ABB DRIVES	Selects the communication profile used by the drive. See section <i>Communication Profiles</i> below.

After the communication activation parameters have been set, the AF 100 interface must be programmed according to its documentation, and the drive control parameters (shown in [Table 4](#)) checked and adjusted where necessary.

In an Optical ModuleBus connection, the channel 0 address (parameter [70.01](#)) is calculated from the value of the POSITION terminal in the appropriate database element (for the AC 80, DRISTD) as follows:

1. Multiply the hundreds of the value of POSITION by 16.
2. Add the tens and ones of the value of POSITION to the result.

For example, if the POSITION terminal of the DRISTD database element has the value of 110 (the tenth drive on the Optical ModuleBus ring), parameter [70.01](#) must be set to $16 \times 1 + 10 = 26$.

In an AC 80 DriveBus connection, the drives are addressed 1 to 12. The drive address (set with parameter [70.01](#)) is related to the value of the DRNR terminal of ACSRX PC element.

Drive control parameters

After the fieldbus communication has been set up, the drive control parameters listed in [Table 4](#) below should be checked and adjusted where necessary.

The **Setting for fieldbus control** column gives the value to use when the fieldbus interface is the desired source or destination for that particular signal. The **Function/Information** column gives a description of the parameter.

The fieldbus signal routes and message composition are explained later under **The fieldbus control interface**.

Table 4 Drive control parameters to be checked and adjusted for fieldbus control.

Parameter	Setting for fieldbus control	Function/Information
CONTROL COMMAND SOURCE SELECTION		
10.01 EXT 1 STRT/STP/DI	COMM. MODULE	Enables the fieldbus Control Word (except bit 11) when EXT1 is selected as the active control location.
10.02 EXT 2 STRT/STP/DI	COMM. MODULE	Enables the fieldbus Control Word (except bit 11) when EXT2 is selected as the active control location.
10.03 DIRECTION	FORWARD, REVERSE or REQUEST	Enables rotation direction control as defined by parameters 10.01 and 10.02.
11.02 EXT1/EXT2 SELECT	COMM. MODULE	Enables EXT1/EXT2 selection by fieldbus Control Word bit 11 EXT CTRL LOC.
11.03 EXT REF1 SELECT	COMM. MODULE	Fieldbus reference REF1 is used when EXT1 is selected as the active control location. See section <i>References</i> below for information on the alternative settings.
11.06 EXT REF2 SELECT	COMM. MODULE	Fieldbus reference REF2 is used when EXT2 is selected as the active control location. See section <i>References</i> below for information on the alternative settings.
OUTPUT SIGNAL SOURCE SELECTION		
14.01 RELAY RO1 OUTPUT	COMM. MODULE	Enables Relay output RO1 control by fieldbus reference REF3 bit 13.
14.02 RELAY RO2 OUTPUT	COMM. MODULE	Enables Relay output RO2 control by fieldbus reference REF3 bit 14.
14.03 RELAY RO3 OUTPUT	COMM. MODULE	Enables Relay output RO3 control by fieldbus reference REF3 bit 15.
15.01 ANALOGUE OUTPUT1	COMM. MODULE	Directs the contents of fieldbus reference REF4 to Analogue output AO1. Scaling: 20000 = 20 mA
15.06 ANALOGUE OUTPUT2	COMM. MODULE	Directs the contents of fieldbus reference REF5 to Analogue output AO2. Scaling: 20000 = 20 mA.

Parameter	Setting for fieldbus control	Function/Information
SYSTEM CONTROL INPUTS		
16.01 RUN ENABLE	COMM. MODULE	Enables the control of the Run Enable signal through fieldbus Control Word bit 3.
16.04 FAULT RESET SEL	COMM. MODULE	Enables fault reset through fieldbus Control Word bit 7.
16.07 PARAMETER BACKUP	DONE; SAVE	Saves parameter value changes (including those made through fieldbus control) to permanent memory.
COMMUNICATION FAULT FUNCTIONS		
30.19 COMM FAULT FUNC	FAULT; NO; PRESET FREQ; LAST FREQ	Determines drive action in case fieldbus communication is lost. Note: The communication loss detection is based on monitoring of received Main and Auxiliary data sets (whose sources are selected with parameters 90.04 and 90.05 respectively).
30.20 MAIN REF DS T-OUT	0.10 ... 60.00 s	Defines the time between Main Reference data set loss detection and the action selected with parameter 30.19.
30.21 COMM FAULT RO/AO	ZERO; LAST VALUE	Determines the state in which Relay outputs RO1 to RO3 and Analogue outputs AO1 and AO2 are left upon loss of the Auxiliary Reference data set.
30.22 AUX REF DS T-OUT	0.00 ... 60.00 s	Defines the time between Auxiliary Reference data set loss detection and the action selected with parameter 30.19. Note: This supervision function is disabled if this parameter, or parameters 90.01, 90.02 and 90.03 are set to 0.
FIELDBUS REFERENCE TARGET SELECTION (Not visible when 98.02 is set to NO.)		
90.01 AUX DS REF3	0 ... 8999	Defines the drive parameter into which the value of fieldbus reference REF3 is written. Format: xyyy , where xx = parameter group (10 to 89), yy = parameter Index. E.g. 3001 = parameter 30.01.
90.02 AUX DS REF4	0 ... 8999	Defines the drive parameter into which the value of fieldbus reference REF4 is written. Format: see parameter 90.01.
90.03 AUX DS REF5	0 ... 8999	Defines the drive parameter into which the value of fieldbus reference REF5 is written. Format: see parameter 90.01.
90.04 MAIN DS SOURCE	1 (Fieldbus Control) or 81 (Standard Modbus Control)	If 98.02 is set to CUSTOMISED, this parameter selects the source from which the drive reads the Main Reference data set (comprising the fieldbus Control Word, fieldbus reference REF1, and fieldbus reference REF2).

Parameter	Setting for fieldbus control	Function/Information
90.05 AUX DS SOURCE	3 (Fieldbus Control) or 83 (Standard Modbus Control)	If 98.02 is set to CUSTOMISED, this parameter selects the source from which the drive reads the Auxiliary Reference data set (comprising fieldbus references REF3, REF4 and REF5).
ACTUAL SIGNAL SELECTION FOR FIELDBUS (Not visible when 98.02 is set to NO.)		
92.01 MAIN DS STATUS WORD	302 (Fixed)	The Status Word is transmitted to as the first word of the Main Actual Signal data set.
92.02 MAIN DS ACT1	0 ... 9999	Selects the Actual signal or parameter value to be transmitted as the second word (ACT1) of the Main Actual Signal data set. Format: (x)xyy, where (x)x = actual signal group or parameter group, yy = actual signal or parameter index. E.g. 103 = actual signal 01.03 FREQUENCY; 2202 = parameter 22.02 ACCEL TIME 1.
92.03 MAIN DS ACT2	0 ... 9999	Selects the Actual signal or parameter value to be transmitted as the third word (ACT2) of the Main Actual Signal data set. Format: see parameter 92.02.
92.04 AUX DS ACT3	0 ... 9999	Selects the Actual signal or parameter value to be transmitted as the first word (ACT3) of the Auxiliary Actual Signal data set. Format: see parameter 92.02.
92.05 AUX DS ACT4	0 ... 9999	Selects the Actual signal or parameter value to be transmitted as the second word (ACT4) of the Auxiliary Actual Signal data set. Format: see parameter 92.02.
92.06 AUX DS ACT5	0 ... 9999	Selects the Actual signal or parameter value to be transmitted as the third word (ACT5) of the Auxiliary Actual Signal data set. Format: see parameter 92.02.

The fieldbus control interface

The communication between a fieldbus system and the drive employs *data sets*. One data set (abbreviated DS) consists of three 16-bit words called data words (DW). The Pump Control Application Program supports the use of four data sets, two in each direction.

The two data sets for controlling the drive are referred to as the Main Reference data set and the Auxiliary Reference data set. The sources from which the drive reads the Main and Auxiliary Reference data sets are defined by parameters 90.04 and 90.05 respectively. The contents of the Main Reference data set are fixed. The contents of the Auxiliary Reference data set can be selected using parameters 90.01, 90.02 and 90.03.

The two data sets containing actual information on the drive are referred to as the Main Actual Signal data set and the Auxiliary Actual Signal data set. The contents of both data sets are partly selectable with the parameters at group 92.

Data from fieldbus controller to drive			Data from drive to fieldbus controller		
Word	Contents	Selector	Word	Contents	Selector
Main Reference data set			Main Actual Signal data set		
1st word	Control Word	(Fixed)	1st word	Status Word	(Fixed)
2nd word	Reference 1	(Fixed)	2nd word	Actual 1	Par. 92.02
3rd word	Reference 2	(Fixed)	3rd word	Actual 2	Par. 92.03
Auxiliary Reference data set			Aux. Actual Signal data set		
1st word	Reference 3	Par. 90.01	1st word	Actual 3	Par. 92.04
2nd word	Reference 4	Par. 90.02	2nd word	Actual 4	Par. 92.05
3rd word	Reference 5	Par. 90.03	3rd word	Actual 5	Par. 92.06

The update time for the Main Reference and Main Actual Signal data sets is 6 milliseconds; for the Auxiliary Reference and Auxiliary Actual Signal data sets, it is 100 milliseconds.

The Control Word and the Status Word

The Control Word (CW) is the principal means of controlling the drive from a fieldbus system. It is effective when the active control location (EXT1 or EXT2, see parameters 10.01 and 10.02) is set to COMM. MODULE.

The Control Word is sent by the fieldbus controller to the drive. The drive switches between its states according to the bit-coded instructions of the Control Word.

The Status Word (SW) is a word containing status information, sent by the drive to the fieldbus controller.

See text under [Communication profiles](#) below for information on the composition of the Control Word and the Status Word.

References

References (REF) are 16-bit signed integers. A negative reference (indicating reversed direction of rotation) is formed by calculating the two's complement from the corresponding positive reference value.

Fieldbus reference selection

Fieldbus reference (sometimes called COM.REF in signal selection contexts) is selected by setting a Reference selection parameter – 11.03 or 11.06 – to COMM. MODULE.

The fieldbus reference is read every 6 milliseconds by the drive.

Fieldbus reference scaling

Reference	Application Macro Used	Reference Type	Range	Scaling	Notes
REF1	(any)	Frequency	-32765 ... 32765	-20000 = [Par. 11.05] 0 = 0 20000 = [Par. 11.05]	Not limited by Pars. 11.04/11.05. (Final reference limited by 20.01/20.02.)
REF2	PFC TRAD	Controller Reference	-32765 ... 32765	-10000 = [Par. 11.08] 0 = 0 10000 = [Pa. 11.08]	
	Multipump				
	Level Control	N/A	N/A	N/A	N/A
	Hand/Auto	Frequency	-32765 ... 32765	-20000 = [Par. 11.05] 0 = 0 20000 = [Par. 11.05]	Not limited by Pars. 11.07/11.08. (Final reference limited by 20.01/20.02.)

Actual values

Actual Values (ACT) are 16-bit words containing information on selected operations of the drive. The functions to be monitored are selected with the parameters in group 92. The scaling of the integers sent to the master as Actual Values depends on the selected function; please refer to the chapter [Actual signals and parameters](#).

Block diagram: Control data input from fieldbus (for type Nxxx fieldbus adapters)

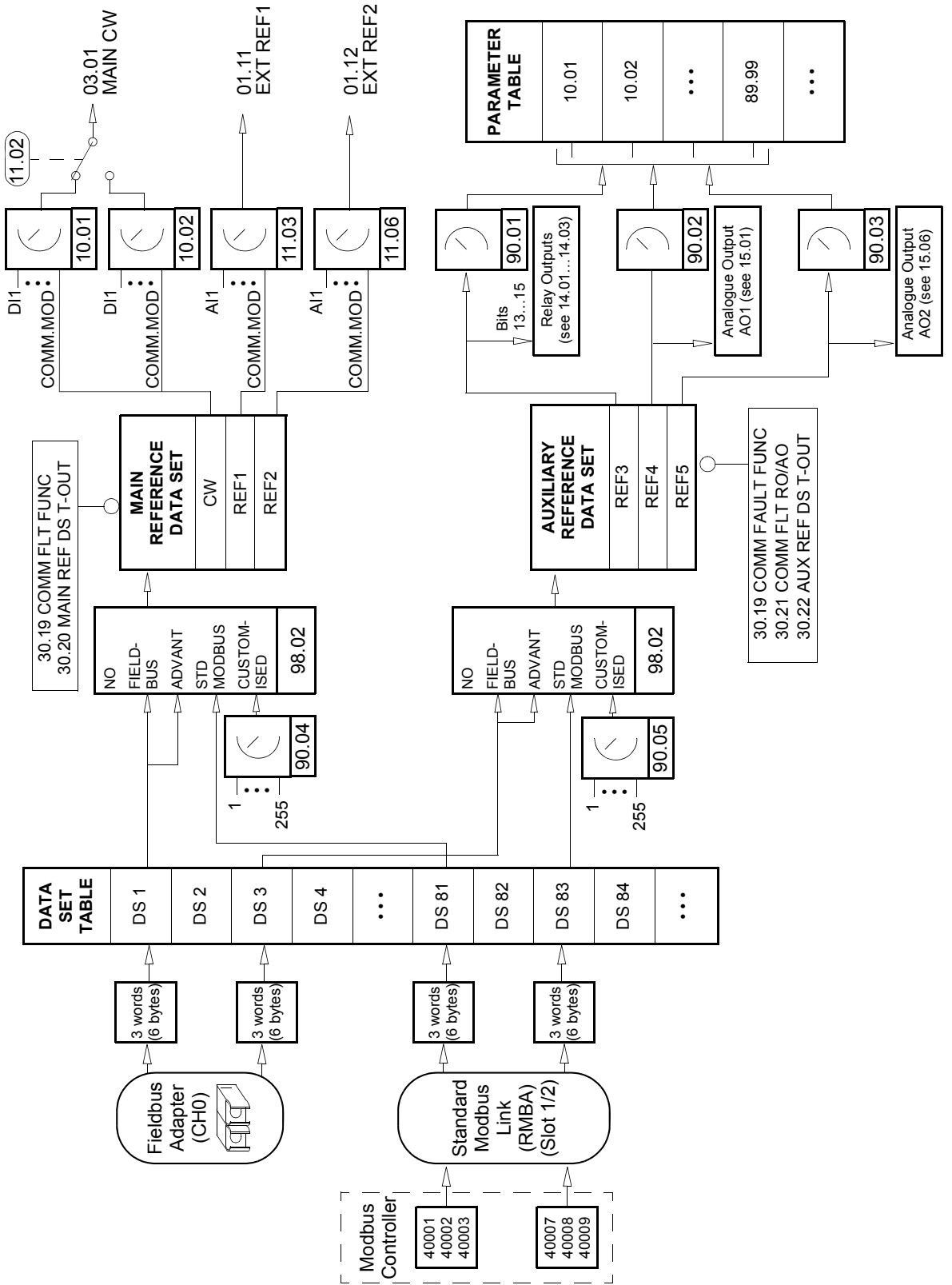

Block diagram: Actual value selection for fieldbus (for type Nxxx fieldbus adapters)

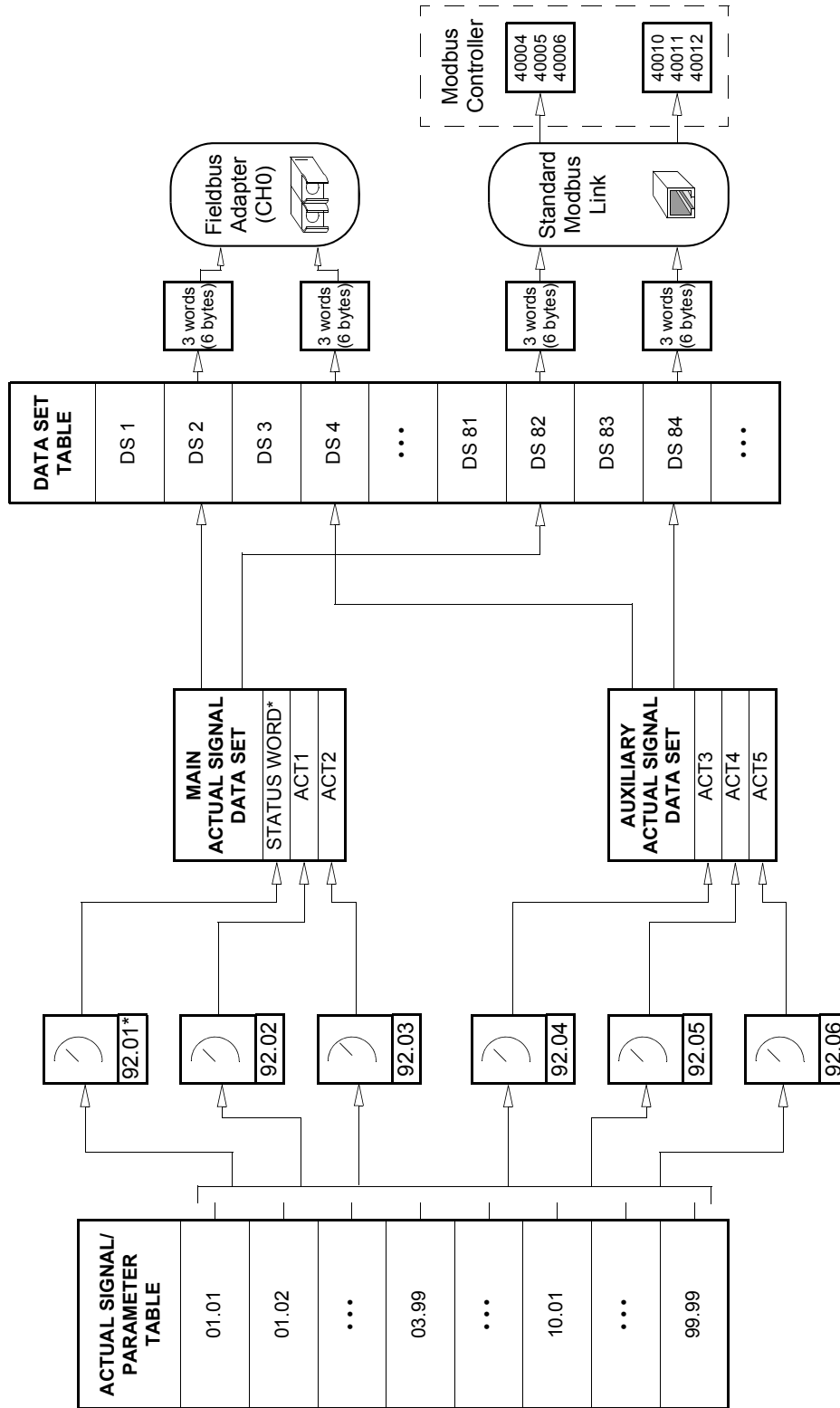

* Fixed to 03.02 MAIN STATUS WORD.

Communication profiles

The PFC Application Program supports two communication profiles:

- ABB Drives communication profile (default)
- CSA 2.8/3.0 communication profile.

The ABB Drives communication profile derives from the PROFIBUS control interface and provides a variety of control and diagnostic functions.

The CSA 2.8/3.0 communication profile can be selected for backward compatibility with PFC Application Program versions 2.8 and 3.0. This eliminates the need for reprogramming the PLC when drives with the above-mentioned program versions are replaced.

The Control Word and Status Word for the CSA 2.8/3.0 communication profile are detailed below.

Note: The communication profile selector parameter (98.07) affects both optical CH0 and the Standard Modbus channels.

ABB Drives communication profile

The ABB Drives communication profile is active when parameter 98.07 is set to ABB DRIVES. The Control Word, Status Word, and reference scaling for the profile are described below.

The ABB Drives communication profile can be used through both EXT1 and EXT2. The Control Word commands are in effect when par. 10.01 or 10.02 (whichever control location is active) is set to COMM. MODULE.

Table 5 The Control Word (Actual signal 03.01) for the ABB Drives communication profile. The upper case boldface text refers to the states shown in Figure 2.

Bit	Name	Value	Enter STATE/Description
0	OFF1 CONTROL	1	Enter READY TO OPERATE .
		0	Stop along currently active deceleration ramp (22.03/22.05). Enter OFF1 ACTIVE ; proceed to READY TO SWITCH ON unless other interlocks (OFF2, OFF3) are active.
1	OFF2 CONTROL	1	Continue operation (OFF2 inactive).
		0	Emergency OFF, coast to stop. Enter OFF2 ACTIVE ; proceed to SWITCH-ON INHIBITED .
2	OFF3 CONTROL	1	Continue operation (OFF3 inactive).
		0	Emergency stop, stop within time defined by par. 22.07. Enter OFF3 ACTIVE ; proceed to SWITCH-ON INHIBITED . Warning: Ensure motor and driven machine can be stopped using this stop mode.
3	INHIBIT_ OPERATION	1	Enter OPERATION ENABLED. (Note: The Run Enable signal must be active; see parameter 16.01. If par. 16.01 is set to COMM. MODULE, this bit also activates the Run Enable signal.)
		0	Inhibit operation. Enter OPERATION INHIBITED .
4	RAMP_OUT_ ZERO	1	Normal operation. Enter RAMP FUNCTION GENERATOR: OUTPUT ENABLED .
		0	Force Ramp Function Generator output to zero. Drive ramps to stop (current and DC voltage limits in force).
5	RAMP_HOLD	1	Enable ramp function. Enter RAMP FUNCTION GENERATOR: ACCELERATOR ENABLED .
		0	Halt ramping (Ramp Function Generator output held).
6	RAMP_IN_ ZERO	1	Normal operation. Enter OPERATING .
		0	Force Ramp Function Generator input to zero.
7	RESET	0 ⇒ 1	Fault reset if an active fault exists. Enter SWITCH-ON INHIBITED .
		0	Continue normal operation.
8	INCHING_1	1	Not in use.
		1 ⇒ 0	Not in use.
9	INCHING_2	1	Not in use.
		1 ⇒ 0	Not in use.
10	REMOTE_CMD	1	Fieldbus control enabled.
		0	Control Word <> 0 or Reference <> 0: Retain last Control Word and Reference. Control Word = 0 and Reference = 0: Fieldbus control enabled. Reference and deceleration/acceleration ramp are locked.
11	EXT CTRL LOC	1	Select External Control Location EXT2. Effective if par. 11.02 is set to COMM. MODULE.
		0	Select External Control Location EXT1. Effective if par. 11.02 is set to COMM. MODULE.
12 ... 15	Reserved		

Table 6 The Status Word (Actual signal 03.02) for the ABB Drives communication profile. The upper case boldface text refers to the states shown in Figure 2.

Bit	Name	Value	STATE/Description
0	RDY_ON	1	READY TO SWITCH ON.
		0	NOT READY TO SWITCH ON.
1	RDY_RUN	1	READY TO OPERATE.
		0	OFF1 ACTIVE.
2	RDY_REF	1	OPERATION ENABLED.
		0	OPERATION INHIBITED.
3	TRIPPED	1	FAULT.
		0	No fault.
4	OFF_2_STA	1	OFF2 inactive.
		0	OFF2 ACTIVE.
5	OFF_3_STA	1	OFF3 inactive.
		0	OFF3 ACTIVE.
6	SWC_ON_INHIB	1	SWITCH-ON INHIBITED.
		0	
7	ALARM	1	Warning/Alarm.
		0	No Warning/Alarm.
8	AT_SETPOINT	1	OPERATING. Actual value equals reference value (= is within tolerance limits).
		0	Actual value differs from reference value (= is outside tolerance limits).
9	REMOTE	1	Drive control location: REMOTE (EXT1 or EXT2).
		0	Drive control location: LOCAL.
10	ABOVE_LIMIT	1	Actual frequency or speed value equals or is greater than supervision limit (par. 32.02). Valid in both rotation directions regardless of value of par. 32.02.
		0	Actual frequency or speed value is within supervision limit.
11	EXT CTRL LOC	1	External Control Location EXT2 selected.
		0	External Control Location EXT1 selected.
12	RUN ENABLE	1	Run Enable signal received.
		0	No Run Enable received.
13, 14	Reserved		
15		1	Communication error detected by fieldbus adapter module (on fibre optic channel CH0).
		0	Fieldbus adapter (CH0) communication OK.

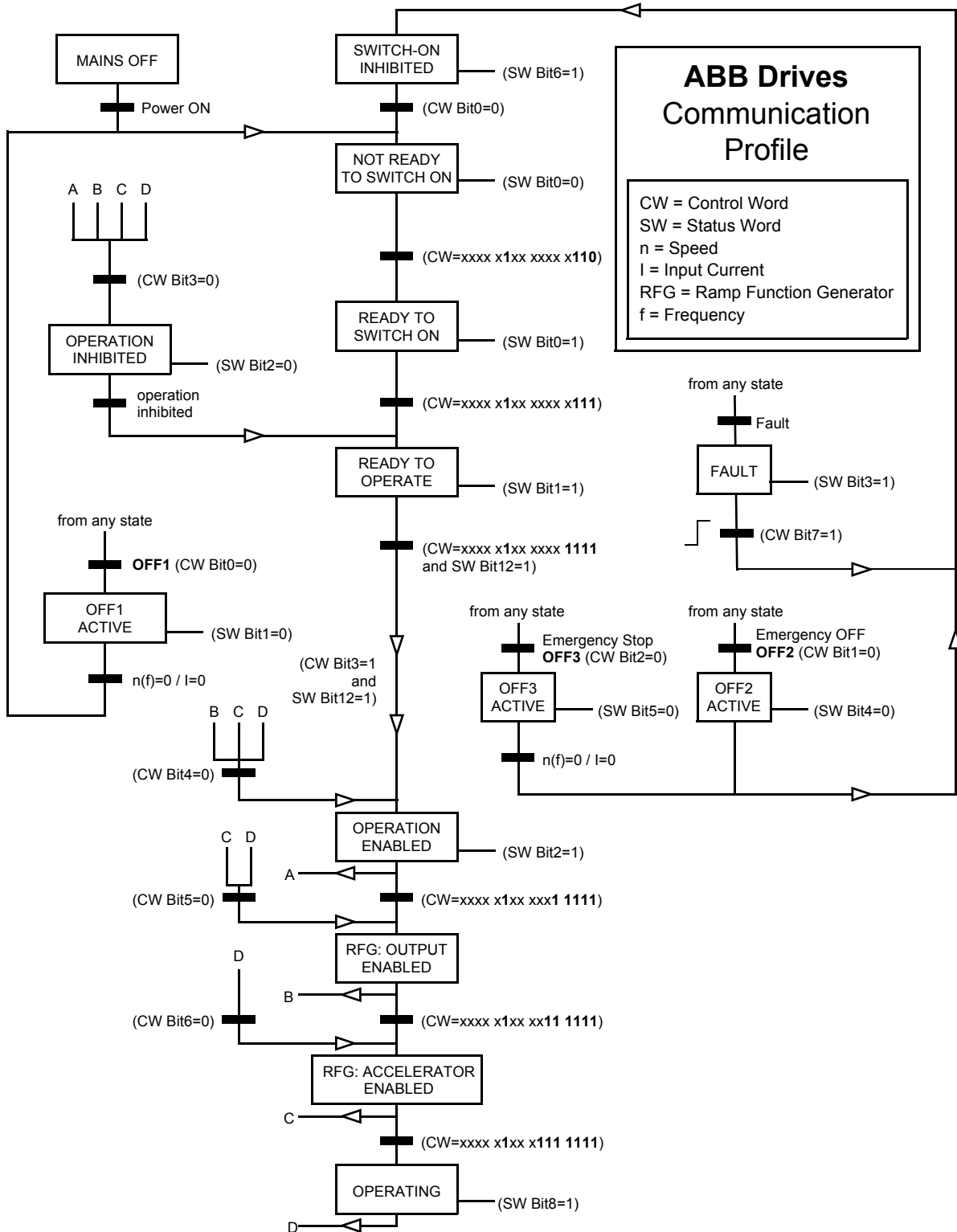

Figure 2 State Machine for the ABB Drives communication profile.

CSA 2.8/3.0 communication profile

The CSA 2.8/3.0 communication profile is active when parameter 98.07 is set to CSA 2.8/3.0. The Control Word and Status Word for the profile are described below.

Table 7 Control Word for the CSA 2.8/3.0 communication profile.

Bit	Name	Value	Description
0	Reserved		
1	ENABLE	1	Enabled
		0	Coast to stop
2	Reserved		
3	START/STOP	0 ⇒ 1	Start
		0	Stop according to parameter 21.03 STOP FUNCTION
4	Reserved		
5	CNTRL_MODE	1	Select control mode 2
		0	Select control mode 1
6	Reserved		
7	Reserved		
8	RESET_FAULT	0 ⇒ 1	Reset drive fault
9 ... 15	Reserved		

Table 8 Status Word for the CSA 2.8/3.0 communication profile.

Bit	Name	Value	Description
0	READY	1	Ready to start
		0	Initialising, or initialising error
1	ENABLE	1	Enabled
		0	Coast to stop
2	Reserved		
3	RUNNING	1	Running with selected reference
		0	Stopped
4	Reserved		
5	REMOTE	1	Drive in Remote mode
		0	Drive in Local mode
6	Reserved		
7	AT_SETPOINT	1	Drive at reference
		0	Drive not at reference
8	FAULTED	1	A fault is active
		0	No active faults
9	WARNING	1	A warning is active
		0	No active warnings
10	LIMIT	1	Drive at a limit
		0	Drive at no limit
11 ... 15	Reserved		

Diverse status, fault, alarm and limit words

Table 9 The Auxiliary Status Word (Actual signal 03.03).

Bit	Name	Description
0	Reserved	
1	OUT OF WINDOW	Speed difference is out of the window (in speed control)*.
2	Reserved	
3	MAGNETIZED	Flux has been formed in the motor.
4	Reserved	
5	SYNC RDY	Position counter synchronised.
6	1 START NOT DONE	Drive has not been started after changing the motor parameters in group 99.
7	IDENTIF RUN DONE	Motor ID Run successfully completed.
8	START INHIBITION	Prevention of unexpected start-up active.
9	LIMITING	Control at a limit. See actual signal 03.04 LIMIT WORD 1 below.
10	TORQ CONTROL	Torque reference is followed*.
11	ZERO SPEED	Absolute value of motor actual speed is below zero speed limit (4% of synchronous speed).
12	INTERNAL SPEED FB	Internal speed feedback followed.
13	M/F COMM ERR	Master/Follower link (on CH2) communication error*.
14 ... 15	Reserved	

*See *Master/Follower Application Guide* (3AFY 58962180 [English]).

Table 10 Limit Word 1 (Actual signal 03.04).

Bit	Name	Active Limit
0	TORQ MOTOR LIM	Pull-out limit.
1	SPD_TOR_MIN_LIM	Speed control torque min. limit.
2	SPD_TOR_MAX_LIM	Speed control torque max. limit.
3	TORQ_USER_CUR_LIM	User-defined current limit.
4	TORQ_INV_CUR_LIM	Internal current limit.
5	TORQ_MIN_LIM	Any torque min. limit.
6	TORQ_MAX_LIM	Any torque max. limit.
7	TREF_TORQ_MIN_LIM	Torque reference min. limit.
8	TREF_TORQ_MAX_LIM	Torque reference max. limit.
9	FLUX_MIN_LIM	Flux reference min. limit.
10	FREQ_MIN_LIMIT	Speed/Frequency min. limit.
11	FREQ_MAX_LIMIT	Speed/Frequency max. limit.
12	DC_UNDERVOLT	DC undervoltage limit.
13	DC_OVERVOLT	DC overvoltage limit.
14	TORQUE LIMIT	Any torque limit.
15	FREQ_LIMIT	Any speed/frequency limit.

Table 11 Fault Word 1 (Actual signal 03.05).

Bit	Name	Description
0	SHORT CIRC	For the possible causes and remedies, see the chapter Fault tracing .
1	OVERCURRENT	
2	DC OVERVOLT	
3	ACS 800 TEMP	
4	EARTH FAULT	
5	THERMISTOR	
6	MOTOR TEMP	
7	SYSTEM_FAULT	A fault is indicated by the System Fault Word (Actual signal 03.07).
8	UNDERLOAD	For the possible causes and remedies, see the chapter Fault tracing .
9	OVERFREQ	
10 ... 15	Reserved	

Table 12 Fault Word 2 (Actual signal 03.06).

Bit	Name	Description
0	SUPPLY PHASE	For the possible causes and remedies, see the chapter <i>Fault tracing</i> .
1	NO MOT DATA	
2	DC UNDERVOLT	
3	Reserved	
4	RUN DISABLE	For the possible causes and remedies, see the chapter <i>Fault tracing</i> .
5	Reserved	
6	I/O COMM ERR	For the possible causes and remedies, see the chapter <i>Fault tracing</i> .
7	CTRL B TEMP	
8	EXTERNAL FLT	
9	OVER SWFREQ	Switching overfrequency fault.
10	AI < MIN FUNC	For the possible causes and remedies, see the chapter <i>Fault tracing</i> .
11	PPCC LINK	
12	COMM MODULE	
13	PANEL LOSS	
14	MOTOR STALL	
15	MOTOR PHASE	

Table 13 The System Fault Word (Actual signal 03.07).

Bit	Name	Description
0	FLT (F1_7)	Factory default parameter file error.
1	USER MACRO	User Macro file error.
2	FLT (F1_4)	FEPROM operating error.
3	FLT (F1_5)	FEPROM data error.
4	FLT (F2_12)	Internal time level 2 overflow.
5	FLT (F2_13)	Internal time level 3 overflow.
6	FLT (F2_14)	Internal time level 4 overflow.
7	FLT (F2_15)	Internal time level 5 overflow.
8	FLT (F2_16)	State machine overflow.
9	FLT (F2_17)	Application program execution error.
10	FLT (F2_18)	Application program execution error.
11	FLT (F2_19)	Illegal instruction.
12	FLT (F2_3)	Register stack overflow.
13	FLT (F2_1)	System stack overflow.
14	FLT (F2_0)	System stack underflow.
15	Reserved	

Table 14 Alarm Word 1 (Actual signal 03.08).

Bit	Name	Description
0	START INHIBIT	For the possible causes and remedies, see the chapter Fault tracing .
1	START INTERLOCK	Start interlock signal is on (starting possible).
2	THERMISTOR	For the possible causes and remedies, see the chapter Fault tracing .
3	MOTOR TEMP	
4	ACS 800 TEMP	
5 ... 11	Reserved	
12	COMM MODULE	For the possible causes and remedies, see the chapter Fault tracing .
13	Reserved	
14	EARTH FAULT	For the possible causes and remedies, see the chapter Fault tracing .
15	Reserved	

Table 15 Alarm Word 2 (Actual signal 03.09).

Bit	Name	Description
0	Reserved	
1	UNDERLOAD (ff6A)	For the possible causes and remedies, see the chapter Fault tracing .
2 ... 6	Reserved	
7	POWFAIL FILE	Error in restoring POWERFAIL.DDF.
8	ALM (OS_17)	Error in restoring POWERDOWN.DDF.
9	MOTOR STALL (7121)	For the possible causes and remedies, see the chapter Fault tracing .
10	AI < MIN FUNC (8110)	
11, 12	Reserved	
13	PANEL LOSS (5300)	For the possible causes and remedies, see the chapter Fault tracing .
14, 15	Reserved	

Table 16 Alarm Word 3 (Actual signal 03.10).

Bit	Name	Description
0	REPLACE FAN	For the possible causes and remedies, see the chapter Fault tracing .
1	SYNCRO SPEED	
2 ... 15	Reserved	

Table 17 Limit Word INV (Actual signal 03.30)

The LIMIT WORD INV word includes faults and warnings which occur when the output current limit of the drive is exceeded. The current limit protects the drive in various cases, e.g. integrator overload and high IGBT temperature.

Bit	Name	Description
0	INTEGRAT 200	Current limit at 200% integrator overload. Temperature model is not active.*
1	INTEGRAT 150	Current limit at 150% integrator overload. Temperature model is not active.*
2	INT LOW FREQ	Current limit at high IGBT temperature with low output frequency (<10 Hz). Temperature model is not active.*
3	INTG PP TEMP	Current limit at high IGBT temperature. Temperature model is not active.*
4	PP OVER TEMP	Current limit at high IGBT temperature. Temperature model is active.*
5	PP OVERLOAD	Current limit at high IGBT junction to case temperature. Temperature model is active.* If the IGBT junction to case temperature continues to rise in spite of the current limitation, PP OVERLOAD warning or fault occurs. See the chapter Fault tracing .
6	INV POW LIM	Current limit at inverter output power limit.
7	INV TRIP CUR	Current limit at inverter overcurrent trip limit.
8	OVERLOAD CUR	Maximum inverter overload current limit. See parameter 20.03 .
9	CONT DC CUR	Continuous DC current limit.
10	CONT OUT CUR	Continuous output current limit (I_{contmax}).
11 ... 15	Reserved	
*Only active with ACS 600 hardware.		

Table 18 PFC Status Word (Actual signal 05.01)

Bit	Name	Value	Description
0	PFC REF	1	An external process reference is in use.
		0	An internal process reference is in use.
1	PFC REF STEP	1	A reference step is active.
		0	No reference steps are active.
2	PFC REF BOOST	1	Sleep boost active.
		0	Sleep boost inactive.
3	PFC REF INLET	1	Low inlet pressure protection active (see parameter group 44).
		0	(Normal operation)
4	PFC REF OUTLET	1	High outlet pressure protection active (see parameter group 44).
		0	(Normal operation)
5	CONT DEV	1	Negative deviation between reference and actual signal.
		0	Positive deviation between reference and actual signal.
6	PROFILE HIGH	1	See parameter group 44.
		0	
7	AUX MOTORS OK	1	Interlocks/auxiliary motors mismatch.
		0	Interlocks and the number of auxiliary motors match.
8	AUTOCHANGE	1	Autochange mode active.
		0	Autochange mode inactive.
9	SLEEP MODE	1	Sleep mode active.
		0	Sleep mode inactive.
10	PI FREEZE	1	PI input or output frozen.
		0	PI input and output free.
11	ANTI-JAM STATUS	1	Anti-jam sequence in progress.
		0	Anti-jam sequence not in progress.
12 ... 15	Reserved		

Table 19 PFC Alarm Word (Actual signal 05.02)

Bit	Name	Description
0	INLET LOW	For the possible causes and remedies, see the chapter Fault tracing .
1	OUTLET HIGH	
2	INLET VERY LOW	
3	OUTLET VERY HIGH	
4	MS INV LOSS	
5	F TO MS CM LOSS	
6 ... 15	Reserved	

Table 20 PFC Fault Word (Actual signal 05.03)

Bit	Name	Description
0	INLET LOW	For the possible causes and remedies, see the chapter Fault tracing .
1	OUTLET HIGH	
2	INLET VERY LOW	
3	OUTLET VERY HIGH	
4	MS INV LOSS	
5	START SEL WRONG	
6 ... 15	Reserved	

Table 21 LC (Level control) Status Word (Actual signal 05.21)

Bit	Name	Description
0	LOW LEVEL 1	In Level control, each bit indicates if a certain pre-defined level has been reached.
1	LOW LEVEL 2	
2	STOP LEVEL	
3	START1 LEVEL	
4	START2 LEVEL	
5	START3 LEVEL	
6	START4 LEVEL	
7	START5 LEVEL	
8	START6 LEVEL	
9	START7 LEVEL	
10	START8 LEVEL	
11	HIGH LEVEL 1	
12	HIGH LEVEL 2	
13	REF SPEED	Indicates whether the drive is running at efficiency speed (par. 47.20) or high speed (par. 47.21). 0 = Efficiency speed 1 = High speed
14 ... 15	Reserved	

Analogue extension module

Chapter overview

The chapter describes the use of analogue extension module RAIO as an speed reference interface of ACS800 equipped with the Pump Control Application Program.

Speed control through the analogue extension module

Only the use of a bipolar input (\pm signal range) is covered here. The use of unipolar input corresponds to that of a standard unipolar input when:

- the settings described below are done, and
- the communication between the module and the drive is activated by parameter [98.06](#).

Basic checks

Ensure the drive is:

- installed and commissioned, and
- the external start and stop signals are connected.

Ensure the extension module:

- settings are adjusted. (See below.)
- is installed and reference signal is connected to AI1.
- is connected to the drive.

Settings of the analogue extension module and the drive

- Set the module node address to 5 (not required if installed to the option slot of the drive).
- Select the signal type for the module input AI1 (switch).
- Select the operation mode (unipolar/bipolar) of the module input (switch).
- Ensure the drive parameter settings correspond to the mode of the module inputs (parameter [98.08](#) and [98.09](#)).
- Set the drive parameters (see the appropriate subsection on the following pages).

Parameter settings: bipolar input in basic speed control

The table below lists the parameters that affect the handling of the speed reference received through the extension module bipolar input AI1 (AI5 of the drive).

Parameter	Setting
98.06 AI/O EXT MODULE	RAIO-SLOT1
98.08 AI/O EXT AI1 FUNC	BIPO AI5
10.03 DIRECTION	FORWARD; REVERSE; REQUEST ⁽¹⁾
11.02 EXT1/EXT2 SELECT	EXT1
11.03 EXT REF1 SELECT	AI5
11.04 EXT REF1 MINIMUM	minREF1
11.05 EXT REF1 MAXIMUM	maxREF1
13.16 MINIMUM AI5	minAI5
13.17 MAXIMUM AI5	maxAI5
13.18 SCALE AI5	100%
13.20 INVERT AI5	NO
30.01 AI<MIN FUNCTION	⁽²⁾

The figure below presents the speed reference corresponding to bipolar input AI1 of the extension module .

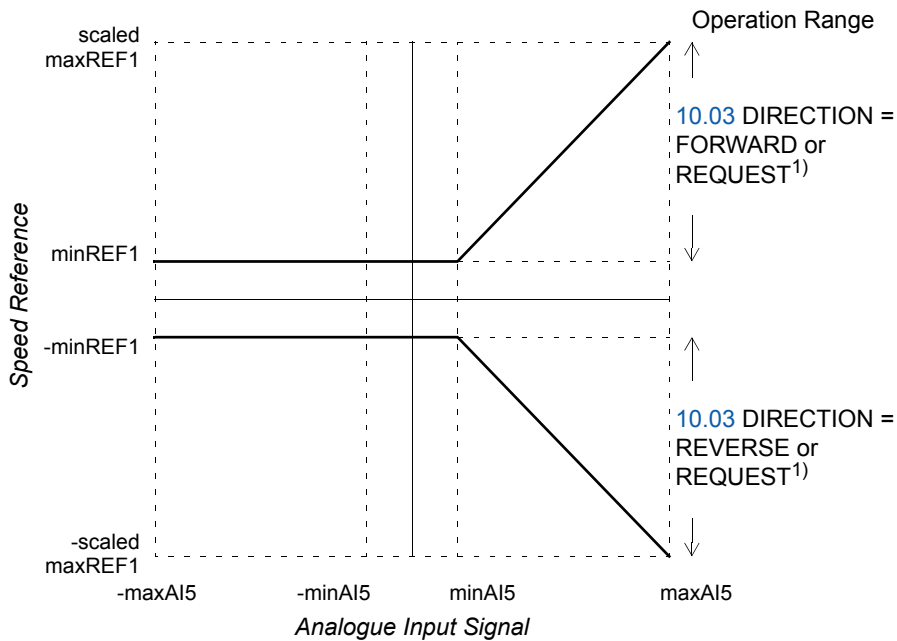

- minAI5 = 13.16 MINIMUM AI5
- maxAI5 = 13.17 MAXIMUM AI5
- scaled maxREF1 = 13.18 SCALE AI5 x 11.05 EXT REF1 MAXIMUM
- minREF1 = 11.04 EXT REF1 MINIMUM

1) For the negative speed range, the drive must receive a separate reverse command.
 2) Set if supervision of living zero is used.

Additional data: actual signals and parameters

Chapter overview

This chapter lists the actual signal and parameter lists with some additional data. For the descriptions, see chapter *Actual signals and parameters*.

Terms and abbreviations

Term	Definition
PB	Parameter address for the fieldbus communication through an NPBA-12 PROFIBUS Adapter.
FbEq	Fieldbus equivalent: The scaling between the value shown on the panel and the integer used in serial communication.
Absolute maximum frequency	Value of 20.02 , or 20.01 if the absolute value of the minimum limit is greater than the maximum limit.
W	Write access is not allowed when the motor is running.

Fieldbus addresses

Rxxx adapter modules (such as RPBA-01, RDNA-01, etc.)

See the appropriate fieldbus adapter module User's Manual.

Nxxx adapter modules (such as NPBA-12, NDNA-02, etc.)

NPBA-12 PROFIBUS Adapter:

- See column **PB** in the tables below.

NIBA-01 InterBus-S Adapter:

- $xyy \times 100 + 12288$ converted into hexadecimal, where xyy = drive parameter number
- Example: The index for drive parameter 13.09 is $1309 + 12288 = 13597$ (decimal) = 351Dh.

NMBA-01 Modbus Adapter and NMBP-01 Modbus Plus Adapter:

- $4xyy$, where xyy = drive parameter number

Actual signals

Index	Name	Short name	FbEq	Unit	Range	PB	
01	ACTUAL SIGNALS						
01.02	MOTOR SPEED FILT	MOTOR SP	-2000 = -100% 2000 = 100% of speed corresponding to absolute maximum frequency	rpm		2	
01.03	FREQUENCY	FREQUENC	-100 = -1 Hz 100 = 1 Hz	Hz		3	
01.04	MOTOR CURRENT	MOTOR CU	10 = 1 A	A		4	
01.05	MOTOR TORQ FILT2	MOTOR TO	-10000 = -100% 10000 = 100% of motor nominal torque	%		5	
01.06	POWER	POWER	0 = 0% 1000 = 100% of motor nominal power	%		6	
01.07	DC VOLTAGE	DC VOLTA	1 = 1 V	V		7	
01.08	MAINS VOLTAGE	MAINS VO	1 = 1 V	V		8	
01.09	MOTOR VOLTAGE	MOTOR VO	1 = 1 V	V		9	
01.10	PP TEMPERATURE	PP TEMPE	1 = 1 °C	C		10	
01.11	EXTERNAL REF 1	EXTERNAL	1 = 1 rpm	rpm		11	
01.12	EXTERNAL REF 2	EXTERNAL	0 = 0% 10000 = 100% (Note 1)	%		12	
01.13	CTRL LOCATION	CTRL LOC	(1,2) LOCAL; (3) EXT1; (4) EXT2		LOCAL; EXT1; EXT2	13	
01.14	TIME OF USAGE	TIME OF	1 = 1 h	h		14	
01.15	KILOWATT HOURS	KILOWATT	1 = 100 kWh	kWh		15	
01.16	APPL BLOCK OUTPUT	APPL BLO	0 = 0% 10000 = 100%	%		16	
01.17	DI6-1 STATUS	DI6-1 ST				17	
01.18	AI1 [V]	AI1 [V]	1 = 0.001 V	V		18	
01.19	AI2 [mA]	AI2 [mA]	1 = 0.001 mA	mA		19	
01.20	AI3 [mA]	AI3 [mA]	1 = 0.001 mA	mA		20	
01.21	RO3-1 STATUS	RO3-1 ST				21	
01.22	AO1 [mA]	AO1 [mA]	1 = 0.001 mA	mA		22	
01.23	AO2 [mA]	AO2 [mA]	1 = 0.001 mA	mA		23	
01.24	ACTUAL VALUE 1	ACTUAL V	0 = 0% 10000 = 100%	%		24	
01.25	ACTUAL VALUE 2	ACTUAL V	0 = 0% 10000 = 100%	%		25	
01.26	CONTROL DEVIATION	CONTROL	-10000 = -100% 10000 = 100%	%		26	
01.27	ACTUAL FUNC OUT	ACTUAL F				27	
01.28	EXT AO1 [mA]	EXT AO1	1 = 0.001 mA	mA		28	
01.29	EXT AO2 [mA]	EXT AO2	1 = 0.001 mA	mA		29	
01.30	PP 1 TEMP	PP 1 TEM	1 = 1 °C	°C		30	
01.31	PP 2 TEMP	PP 2 TEM	1 = 1 °C	°C		31	
01.32	PP 3 TEMP	PP 3 TEM	1 = 1 °C	°C		32	
01.33	PP 4 TEMP	PP 4 TEM	1 = 1 °C	°C		33	
01.37	MOTOR TEMP EST	MOTOR TE	1 = 1 °C	°C		37	
01.38	AI5 [mA]	AI5 [mA]	1 = 0.001 mA	mA		38	
01.39	AI6 [mA]	AI6 [mA]	1 = 0.001 mA	mA		39	
01.40	DI7-12 STATUS	DI7..12 S	1 = 1			40	
01.41	EXT RO STATUS	EXT RO S	1 = 1			41	
01.42	PFC OPERATION TIM	PFC OPER	1 = 1	h		42	

Additional data: actual signals and parameters

Index	Name	Short name	FbEq	Unit	Range	PB	
01.43	MOTOR RUN-TIME	MOTOR RU	1 = 10 h	h		43	
01.44	FAN ON-TIME	FAN ON-T	1 = 10 h	h		44	
01.45	CTRL BOARD TEMP	CTRL BOA	1 = 1 °C	°C		45	
01.47	M/F STATE	M/F STAT	(0,1) FOLLOWER; (2) MASTER		FOLLOWER; MASTER	47	
01.48	START COUNTER	START CO	1 = 1			48	
01.50	SAVED KWH	SAV KWH	1 = 100 kWh	kWh	0...999 999	-	
01.51	SAVED GWH	SAV GWH	1 = 1 GWh	GWh	1...8388607	-	
01.52	SAVED AMOUNT	SAV AM	1 = 100 cur	local; EUR; USD	0...999 999	-	
01.53	SAVED AMOUNT M	SAV AM M	1 = 1 Mcur	local; EUR; USD	1...8388607	-	
01.54	SAVED CO2	SAV CO2	1 = 100 kg	kg	0...999 999	-	
01.55	SAVED CO2 KTON	SAV CO2K	1 = 1 kton	kton	1...8388607	-	
02	ACTUAL SIGNALS						
02.01	SPEED REF 2	SPEED RE	0 = 0%	rpm		51	
02.02	SPEED REF 3	SPEED RE	20000 = 100% of motor absolute max. frequency	rpm		52	
02.09	TORQUE REF 2	TORQUE R	0 = 0%	%		59	
02.10	TORQUE REF 3	TORQUE R	10000 = 100% of motor nominal torque	%		60	
02.13	TORQ USED REF	TORQ USE		%		63	
02.17	SPEED ESTIMATED	SPEED ES	0 = 0% 20000 = 100% of motor absolute max. frequency	rpm		67	
02.19	MOTOR ACCELERATIO	MOTOR AC	1 = 1 rpm/s	rpm/s		69	
03	INTERNAL DATA						
03.01	MAIN CONTROL WORD	MAIN CON	(Note 2)		0 ... 65535 (Decimal)	76	
03.02	MAIN STATUS WORD	MAIN STA	(Note 2)		0 ... 65535 (Decimal)	77	
03.03	AUX STATUS WORD	AUX STAT	(Note 2)		0 ... 65535 (Decimal)	78	
03.04	LIMIT WORD 1	LIMIT WO	(Note 2)		0 ... 65535 (Decimal)	79	
03.05	FAULT WORD 1	FAULT WO	(Note 2)		0 ... 65535 (Decimal)	80	
03.06	FAULT WORD 2	FAULT WO	(Note 2)		0 ... 65535 (Decimal)	81	
03.07	SYSTEM FAULT WORD	SYSTEM F	(Note 2)		0 ... 65535 (Decimal)	82	
03.08	ALARM WORD 1	ALARM WO	(Note 2)		0 ... 65535 (Decimal)	83	
03.09	ALARM WORD 2	ALARM WO	(Note 2)		0 ... 65535 (Decimal)	84	
03.10	ALARM WORD 3	ALARM WO	(Note 2)		0 ... 65535 (Decimal)	85	
03.19	INT INIT FAULT	INT INIT			0 ... 65535 (Decimal)	93	
03.20	FAULT CODE 1 LAST	FAULT CO			0 ... 65535 (Decimal)	94	
03.21	FAULT CODE 2 LAST	FAULT CO			0 ... 65535 (Decimal)	95	
03.22	FAULT CODE 3 LAST	FAULT CO			0 ... 65535 (Decimal)	96	

Index	Name	Short name	FbEq	Unit	Range	PB	
03.23	FAULT CODE 4 LAST	FAULT CO			0 ... 65535 (Decimal)	97	
03.24	FAULT CODE 5 LAST	FAULT CO			0 ... 65535 (Decimal)	98	
03.25	WARN CODE 1 LAST	WARN COD			0 ... 65535 (Decimal)	99	
03.26	WARN CODE 2 LAST	WARN COD			0 ... 65535 (Decimal)	-	
03.27	WARN CODE 3 LAST	WARN COD			0 ... 65535 (Decimal)	-	
03.28	WARN CODE 4 LAST	WARN COD			0 ... 65535 (Decimal)	-	
03.29	WARN CODE 5 LAST	WARN COD			0 ... 65535 (Decimal)	-	
03.30	LIMIT WORD INV	LIMIT WO			0 ... 65535 (Decimal)	-	
05	PFC WORDS						
05.01	PFC STATUS	PFC STAT	(Note 2)		0 ... 65535 (Decimal)	-	
05.02	PFC ALARM WORD	PFC ALAR	(Note 2)		0 ... 65535 (Decimal)	-	
05.03	PFC FAULT WORD	PFC FAUL	(Note 2)		0 ... 65535 (Decimal)	-	
05.04	PFC ACT REF	PFC ACT		%	-500 ... 500	-	
05.05	APPLIC REF AS Hz	APPLIC R		Hz	-500 ... 500	-	
05.06	AUX ON	AUX ON	1 = 1			-	
05.07	WAKE UP ACT	WAKE UP		%	-500 ... 500	-	
05.08	BOOST ACT	BOOST AC		%	-500 ... 500	-	
05.11	ACT FLOW	ACT FLOW		m ³ /h		-	
05.12	SUM FLOW	SUM FLOW		m ³		-	
05.13	PRESSURE DEV	PRESSURE		bar		-	
05.15	SHARE AI1	SHARE AI	1 = 0.001 V	V		-	
05.16	SHARE AI2	SHARE AI	1 = 0.001 mA	mA		-	
05.17	SHARE AI3	SHARE AI	1 = 0.001 mA	mA		-	
05.21	LC STATUS	LC STATU	(Note 2)			-	
05.23	ACT LEVEL	ACT LEVE		%		-	
09	ACTUAL SIGNALS						
09.01	AI1 SCALED	AI1 SCAL	20000 = 10 V		0 ... 20000	-	
09.02	AI2 SCALED	AI2 SCAL	20000 = 20 mA		0 ... 20000	-	
09.03	AI3 SCALED	AI3 SCAL	20000 = 20 mA		0 ... 20000	-	
09.04	AI5 SCALED	AI5 SCAL	20000 = 20 mA		0 ... 20000	-	
09.05	AI6 SCALED	AI6 SCAL	20000 = 20 mA		0 ... 20000	-	
09.06	DS MCW	DS MCW	0 ... 65535 (Decimal)		0 ... 65535 (Decimal)	-	
09.07	MASTER REF1	MASTER R	-32768 ... 32767		-32768 ... 32767	-	
09.08	MASTER REF2	MASTER R	-32768 ... 32767		-32768 ... 32767	-	
09.09	AUX DS VAL1	AUX DS V	-32768 ... 32767		-32768 ... 32767	-	
09.10	AUX DS VAL2	AUX DS V	-32768 ... 32767		-32768 ... 32767	-	
09.11	AUX DS VAL3	AUX DS V	-32768 ... 32767		-32768 ... 32767	-	
09.12	LCU ACT SIGNAL 1	LCU ACT1	-	-	-	-	
09.13	LCU ACT SIGNAL 2	LCU ACT2	-	-	-	-	

(Note 1) Percent of maximum process reference (PFC TRAD macro) or maximum frequency (Hand/ Auto macro).

(Note 2) The contents of these data words are detailed in the chapter [Fieldbus control](#).

Parameters

Index	Name/Selection	Default setting						PB	W
		MULTIMAS-TER	PFC TRAD	HAND/AUTO	LEVEL CTRL	USER 1	USER 2		
10	START/STOP/DIR								
10.01	EXT 1 STRT/STP/DI	DI1	DI1	DI1	DI1			101	W
10.02	EXT 2 STRT/STP/DI	DI6	DI6	DI6	DI6			102	W
10.03	DIRECTION	FORWARD	FORWARD	FORWARD	FORWARD			103	W
10.04	EXT 1 STRT PTR	0	0	0	0			104	W
10.05	EXT 2 STRT PTR	0	0	0	0			105	W
11	REFERENCE SELECT								
11.02	EXT1/EXT2 SELECT	EXT2	EXT2	DI5	EXT2			127	W
11.03	EXT REF1 SELECT	AI1	AI1	AI1	AI1			128	W
11.04	EXT REF1 MINIMUM	0 Hz	0 Hz	0 Hz	0 Hz			129	
11.05	EXT REF1 MAXIMUM	52 Hz	52 Hz	52 Hz	52 Hz			130	
11.06	EXT REF2 SELECT	AI1	AI1	AI2	AI1			131	W
11.07	EXT REF2 MINIMUM	0%	0%	0%	0%			132	
11.08	EXT REF2 MAXIMUM	100%	100%	100%	100%			133	
11.09	EXT 1/2 SEL PTR	0	0	0	0			134	
11.10	EXT 1 REF PTR	0	0	0	0			135	
11.11	EXT 2 REF PTR	0	0	0	0			136	
12	CONSTANT FREQ								
12.01	CONST FREQ SEL	NOT SEL	NOT SEL	NOT SEL	NOT SEL			151	
12.02	CONST FREQ 1	25 Hz	25 Hz	25 Hz	25 Hz			152	
12.03	CONST FREQ 2	30 Hz	30 Hz	30 Hz	30 Hz			153	
12.04	CONST FREQ 3	35 Hz	35 Hz	35 Hz	35 Hz			154	
13	ANALOGUE INPUTS								
13.01	MINIMUM AI1	0 V	0 V	0 V	0 V			176	
13.02	MAXIMUM AI1	10 V	10 V	10 V	10 V			177	
13.03	SCALE AI1	100.0%	100.0%	100.0%	100.0%			178	
13.04	FILTER AI1	0.10 s	0.10 s	0.10 s	0.10 s			179	
13.05	INVERT AI1	NO	NO	NO	NO			180	
13.06	MINIMUM AI2	4 mA	4 mA	4 mA	4 mA			181	
13.07	MAXIMUM AI2	20 mA	20 mA	20 mA	20 mA			182	
13.08	SCALE AI2	100.0%	100.0%	100.0%	100.0%			183	
13.09	FILTER AI2	0.10 s	0.10 s	0.10 s	0.10 s			184	
13.10	INVERT AI2	NO	NO	NO	NO			185	
13.11	MINIMUM AI3	4 mA	4 mA	4 mA	4 mA			186	
13.12	MAXIMUM AI3	20 mA	20 mA	20 mA	20 mA			187	
13.13	SCALE AI3	100.0%	100.0%	100.0%	100.0%			188	
13.14	FILTER AI3	0.10 s	0.10 s	0.10 s	0.10 s			189	
13.15	INVERT AI3	NO	NO	NO	NO			190	
13.16	MINIMUM AI5	4 mA	4 mA	4 mA	4 mA			191	
13.17	MAXIMUM AI5	20 mA	20 mA	20 mA	20 mA			192	
13.18	SCALE AI5	100.0%	100.0%	100.0%	100.0%			193	
13.19	FILTER AI5	0.10 s	0.10 s	0.10 s	0.10 s			194	
13.20	INVERT AI5	NO	NO	NO	NO			195	
13.21	MINIMUM AI6	4 mA	4 mA	4 mA	4 mA			196	
13.22	MAXIMUM AI6	20 mA	20 mA	20 mA	20 mA			197	
13.23	SCALE AI6	100.0%	100.0%	100.0%	100.0%			198	
13.24	FILTER AI6	0.10 s	0.10 s	0.10 s	0.10 s			199	
13.25	INVERT AI6	NO	NO	NO	NO			200	
14	RELAY OUTPUTS								
14.01	RELAY RO1 OUTPUT	READY	M1 START	READY	READY			201	W
14.02	RELAY RO2 OUTPUT	RUNNING	M2 START	RUNNING	RUNNING			202	W
14.03	RELAY RO3 OUTPUT	FAULT(-1)	FAULT	FAULT(-1)	FAULT(-1)			203	W
14.04	RDIO MOD1 RO1	READY	READY	READY	READY			204	W

Index	Name/Selection	Default setting						PB	W
		MULTIMAS-TER	PFC TRAD	HAND/AUTO	LEVEL CTRL	USER 1	USER 2		
14.05	RDIO MOD1 RO2	RUNNING	RUNNING	RUNNING	RUNNING			205	W
14.06	RDIO MOD2 RO1	FAULT	FAULT	FAULT	FAULT			206	W
14.07	RDIO MOD2 RO2	FAULT(-1)	FAULT(-1)	FAULT(-1)	FAULT(-1)			207	W
14.08	RO PTR1	0	0	0	0			208	W
14.09	RO PTR2	0	0	0	0			209	W
14.10	RO PTR3	0	0	0	0			210	W
14.11	RO PTR4	0	0	0	0			211	W
14.12	RO PTR5	0	0	0	0			212	W
14.13	RO PTR6	0	0	0	0			213	W
14.14	RO PTR7	0	0	0	0			214	W
15	ANALOGUE OUTPUTS								
15.01	ANALOGUE OUTPUT1	FREQUENCY	FREQUENCY	FREQUENCY	FREQUENCY			226	W
15.02	INVERT AO1	NO	NO	NO	NO			227	
15.03	MINIMUM AO1	0 mA	0 mA	0 mA	0 mA			228	
15.04	FILTER AO1	2.00 s	2.00 s	2.00 s	2.00 s			229	
15.05	SCALE AO1	100%	100%	100%	100%			230	
15.06	ANALOGUE OUTPUT2	ACTUAL 1	ACTUAL 1	CURRENT	ACTUAL 1			231	W
15.07	INVERT AO2	NO	NO	NO	NO			232	
15.08	MINIMUM AO2	0 mA	0 mA	0 mA	0 mA			233	
15.09	FILTER AO2	2.00 s	2.00 s	2.00 s	2.00 s			234	
15.10	SCALE AO2	100%	100%	100%	100%			235	
15.11	AO1 PTR	0	0	0	0			236	
15.12	AO2 PTR	0	0	0	0			237	
16	SYSTEM CTR INPUT								
16.01	RUN ENABLE	YES	YES	YES	YES			251	W
16.02	PARAMETER LOCK	OPEN	OPEN	OPEN	OPEN			252	
16.03	PASS CODE	0	0	0	0			253	
16.04	FAULT RESET SEL	NOT SEL	NOT SEL	NOT SEL	NOT SEL			254	W
16.05	USER MACRO IO CHG	NOT SEL	NOT SEL	NOT SEL	NOT SEL			255	W
16.06	LOCAL LOCK	FALSE	FALSE	FALSE	FALSE			256	
16.07	PARAMETER BACKUP	DONE	DONE	DONE	DONE			257	
16.08	RUN ENA PTR	0	0	0	0			258	
16.09	CTRL BOARD SUPPLY	INTERNAL 24V	INTERNAL 24V	INTERNAL 24V	INTERNAL 24V			259	
16.10	FAULT RESET PTR	0	0	0	0			260	
16.12	RESET COUNTER	NO	NO	NO	NO			-	
20	LIMITS								
20.01	MINIMUM FREQ	0.00 Hz	0.00 Hz	0.00 Hz	0.00 Hz			351	
20.02	MAXIMUM FREQ	(calculated)	(calculated)	(calculated)	(calculated)			352	
20.03	MAXIMUM CURRENT A	(drive type-specific)	(drive type-specific)	(drive type-specific)	(drive type-specific)			353	
20.04	MAXIMUM TORQUE	300.0%	300.0%	300.0%	300.0%			354	
20.05	OVERVOLTAGE CTL	ON	ON	ON	ON			355	
20.06	UNDERVOLTAGE CTL	ON	ON	ON	ON			356	
20.07	PI MIN FREQ	0.00 Hz	0.00 Hz	0.00 Hz	0.00 Hz			357	
20.11	P MOTORING LIM	300.0%	300.0%	300.0%	300.0%			361	
20.12	P GENERATING LIM	-300.0%	-300.0%	-300.0%	-300.0%			362	
21	START/STOP								
21.01	START FUNCTION	AUTO	AUTO	AUTO	AUTO			376	W
21.02	CONST MAGN TIME	500.0 ms	500.0 ms	500.0 ms	500.0 ms			377	W

Additional data: actual signals and parameters

Index	Name/Selection	Default setting						PB	W
		MULTIMAS-TER	PFC TRAD	HAND/AUTO	LEVEL CTRL	USER 1	USER 2		
21.03	STOP FUNCTION	RAMP	COAST	COAST	RAMP			378	
21.07	RUN ENABLE FUNC	RAMP STOP	COAST STOP	COAST STOP	RAMP STOP			382	
21.08	SCALAR FLYSTART	OFF	OFF	OFF	OFF			383	W
21.09	START INTRL FUNC	OFF2 STOP	OFF2 STOP	OFF2 STOP	OFF2 STOP			384	
22	ACCEL/DECEL								
22.01	ACC/DEC 1/2 SEL	ACC/DEC 1	ACC/DEC 1	ACC/DEC 1	ACC/DEC 1			401	W
22.02	ACCEL TIME 1	3.00 s	3.00 s	3.00 s	3.00 s			402	
22.03	DECEL TIME 1	3.00 s	3.00 s	3.00 s	3.00 s			403	
22.04	ACCEL TIME 2	1.00 s	1.00 s	1.00 s	1.00 s			404	
22.05	DECEL TIME 2	1.00 s	1.00 s	1.00 s	1.00 s			405	
22.06	SHAPE TIME	0.00 s	0.00 s	0.00 s	0.00 s			406	
22.07	STOP RAMP TIME	3.00 s	3.00 s	3.00 s	3.00 s			407	
22.08	ACC PTR	0	0	0	0			408	
22.09	DEC PTR	0	0	0	0			409	
23	SPEED CTRL								
23.01	KPS	10.0	10.0	10.0	10.0			426	
23.02	TIS	2.50 s	2.50 s	2.50 s	2.50 s			427	
23.03	SLIP GAIN	0.0%	0.0%	0.0%	0.0%			428	
25	CRITICAL FREQ								
25.01	CRIT FREQ SELECT	OFF	OFF	OFF	OFF			476	
25.02	CRIT FREQ 1 LOW	0 Hz	0 Hz	0 Hz	0 Hz			477	
25.03	CRIT FREQ 1 HIGH	0 Hz	0 Hz	0 Hz	0 Hz			478	
25.04	CRIT FREQ 2 LOW	0 Hz	0 Hz	0 Hz	0 Hz			479	
25.05	CRIT FREQ 2 HIGH	0 Hz	0 Hz	0 Hz	0 Hz			480	
26	MOTOR CONTROL								
26.01	FLUX OPTIMIZATION	NO	NO	NO	NO			501	W
26.02	FLUX BRAKING	YES	YES	YES	YES			502	W
26.03	IR COMPENSATION	0.0%	0.0%	0.0%	0.0%			503	W
26.04	HEX FIELD WEAKEN	OFF	OFF	OFF	OFF			504	W
30	FAULT FUNCTIONS								
30.01	AI<MIN FUNCTION	FAULT	FAULT	FAULT	FAULT			601	
30.02	PANEL LOSS	FAULT	FAULT	FAULT	FAULT			602	
30.03	EXTERNAL FAULT	NOT SEL	NOT SEL	NOT SEL	NOT SEL			603	
30.04	MOT THERM PROT	NO	NO	NO	NO			604	
30.05	MOTOR THERM PMODE	DTC	DTC	DTC	DTC			605	
30.06	MOTOR THERM TIME	(calculated)	(calculated)	(calculated)	(calculated)			606	
30.07	MOTOR LOAD CURVE	100.0%	100.0%	100.0%	100.0%			607	
30.08	ZERO SPEED LOAD	74.0%	74.0%	74.0%	74.0%			608	
30.09	BREAK POINT	45.0 Hz	45.0 Hz	45.0 Hz	45.0 Hz			609	
30.10	STALL FUNCTION	FAULT	FAULT	FAULT	FAULT			610	
30.11	STALL FREQ HI	20.0 Hz	20.0 Hz	20.0 Hz	20.0 Hz			611	
30.12	STALL TIME	20.00 s	20.00 s	20.00 s	20.00 s			612	
30.13	UNDERLOAD FUNCTIO	NO	NO	NO	NO			613	
30.14	UNDERLOAD TIME	600 s	600 s	600 s	600 s			614	
30.15	UNDERLOAD CURVE	1	1	1	1			615	
30.16	MOTOR PHASE LOSS	NO	NO	NO	NO			616	
30.17	EARTH FAULT	FAULT	FAULT	FAULT	FAULT			617	
30.18	PRESET FREQ	10.00 Hz	10.00 Hz	10.00 Hz	10.00 Hz			618	
30.19	COMM FAULT FUNC	FAULT	FAULT	FAULT	FAULT			619	
30.20	MAIN REF DS T-OUT	1.00 s	1.00 s	1.00 s	1.00 s			620	

Index	Name/Selection	Default setting						PB	W
		MULTIMAS-TER	PFC TRAD	HAND/AUTO	LEVEL CTRL	USER 1	USER 2		
30.21	COMM FAULT RO/AO	ZERO	ZERO	ZERO	ZERO			621	
30.22	AUX REF DS T-OUT	3.00 s	3.00 s	3.00 s	3.00 s			622	
30.23	LIMIT WARNING	0000000	0000000	0000000	0000000			623	
31	AUTOMATIC RESET								
31.01	NUMBER OF TRIALS	0	0	0	0			626	
31.02	TRIAL TIME	30.0 s	30.0 s	30.0 s	30.0 s			627	
31.03	DELAY TIME	0.0 s	0.0 s	0.0 s	0.0 s			628	
31.04	OVERCURRENT	NO	NO	NO	NO			629	
31.05	OVERVOLTAGE	NO	NO	NO	NO			630	
31.06	UNDERVOLTAGE	NO	NO	NO	NO			631	
31.07	AI SIGNAL<MIN	NO	NO	NO	NO			632	
32	SUPERVISION								
32.01	FREQ1 FUNCTION	NO	NO	NO	NO			651	
32.02	FREQ1 LIMIT	0 Hz	0 Hz	0 Hz	0 Hz			652	
32.03	FREQ2 FUNCTION	NO	NO	NO	NO			653	
32.04	FREQ2 LIMIT	0 Hz	0 Hz	0 Hz	0 Hz			654	
32.05	CURRENT FUNCTION	NO	NO	NO	NO			655	
32.06	CURRENT LIMIT	0 A	0 A	0 A	0 A			656	
32.07	REF1 FUNCTION	NO	NO	NO	NO			657	
32.08	REF1 LIMIT	0 Hz	0 Hz	0 Hz	0 Hz			658	
32.09	REF2 FUNCTION	NO	NO	NO	NO			659	
32.10	REF2 LIMIT	0%	0%	0%	0%			660	
32.11	ACT1 FUNCTION	NO	NO	NO	NO			661	
32.12	ACT1 LIMIT	0%	0%	0%	0%			662	
32.13	ACT2 FUNCTION	NO	NO	NO	NO			663	
32.14	ACT2 LIMIT	0%	0%	0%	0%			664	
32.15	RESET START CNT	NO	NO	NO	NO			665	
33	INFORMATION								
33.01	SW PACKAGE VER	(Version)	(Version)	(Version)	(Version)			676	
33.02	APPLIC NAME	(Version)	(Version)	(Version)	(Version)			677	
33.03	TEST DATE	(Date)	(Date)	(Date)	(Date)			678	
40	PI-CONTROLLER								
40.01	PI GAIN	2.5	2.5	N/A	N/A			851	
40.02	PI INTEG TIME	3.00 s	3.00 s	N/A	N/A			852	
40.03	ERROR VALUE INV	NO	NO	N/A	N/A			853	
40.04	ACTUAL VALUE SEL	ACT1	ACT1	N/A	N/A			854	
40.05	ACTUAL1 INPUT SEL	AI2	AI2	N/A	N/A			855	
40.06	ACTUAL2 INPUT SEL	AI3	AI3	N/A	N/A			856	
40.07	ACT1 MINIMUM	0%	0%	N/A	N/A			857	
40.08	ACT1 MAXIMUM	100%	100%	N/A	N/A			858	
40.09	ACT2 MINIMUM	0%	0%	N/A	N/A			859	
40.10	ACT2 MAXIMUM	100%	100%	N/A	N/A			860	
40.11	ACT1 UNIT SCALE	0.10	0.10	N/A	N/A			861	
40.12	ACTUAL 1 UNIT	bar	bar	N/A	N/A			862	
40.13	ACT2 UNIT SCALE	0.10	0.10	N/A	N/A			863	
40.14	ACTUAL 2 UNIT	bar	bar	N/A	N/A			864	
40.15	ACTUAL FUNC SCALE	0.10	0.10	N/A	N/A			865	
40.16	ACTUAL1 PTR	0	0	N/A	N/A			866	
41	PFC-CONTROL 1								
41.01	SET POINT 1/2 SEL	SET POINT 1	SET POINT 1	N/A	N/A			876	
41.02	SET POINT 1 SRCE	INTERNAL	INTERNAL	N/A	N/A			877	
41.03	SPOINT 1 INTERNAL	40.0%	40.0%	N/A	N/A			878	
41.04	SPOINT 2 INTERNAL	40.0%	40.0%	N/A	N/A			879	
41.05	REFERENCE STEP 1	0.0%	0.0%	N/A	N/A			880	

Additional data: actual signals and parameters

Index	Name/Selection	Default setting						PB	W
		MULTIMAS- TER	PFC TRAD	HAND/AUTO	LEVEL CTRL	USER 1	USER 2		
41.06	REFERENCE STEP 2	0.0%	0.0%	N/A	N/A			881	
41.07	REFERENCE STEP 3	0.0%	0.0%	N/A	N/A			882	
41.08	REFERENCE STEP 4	0.0%	0.0%	N/A	N/A			883	
41.09	REFERENCE STEP 5	0.0%	0.0%	N/A	N/A			884	
41.10	REFERENCE STEP 6	0.0%	0.0%	N/A	N/A			885	
41.11	REFERENCE STEP 7	0.0%	0.0%	N/A	N/A			886	
41.12	START FREQ 1	50.0 Hz	50.0 Hz	N/A	N/A			887	
41.13	START FREQ 2	50.0 Hz	50.0 Hz	N/A	N/A			888	
41.14	START FREQ 3	50.0 Hz	50.0 Hz	N/A	N/A			889	
41.15	START FREQ 4	50.0 Hz	50.0 Hz	N/A	N/A			890	
41.16	START FREQ 5	50.0 Hz	50.0 Hz	N/A	N/A			891	
41.17	START FREQ 6	50.0 Hz	50.0 Hz	N/A	N/A			892	
41.18	START FREQ 7	50.0 Hz	50.0 Hz	N/A	N/A			893	
41.19	LOW FREQ 1	25.0 Hz	25.0 Hz	N/A	N/A			894	
41.20	LOW FREQ 2	25.0 Hz	25.0 Hz	N/A	N/A			895	
41.21	LOW FREQ 3	25.0 Hz	25.0 Hz	N/A	N/A			896	
41.22	LOW FREQ 4	25.0 Hz	25.0 Hz	N/A	N/A			897	
41.23	LOW FREQ 5	25.0 Hz	25.0 Hz	N/A	N/A			898	
41.24	LOW FREQ 6	25.0 Hz	25.0 Hz	N/A	N/A			899	
41.25	LOW FREQ 7	25.0 Hz	25.0 Hz	N/A	N/A			900	
41.26	FOLLOWER START DL	5.0 s	5.0 s	N/A	N/A			-	
41.27	FOLLOWER STOP DLY	3.0 s	3.0 s	N/A	N/A			-	
42	PFC CONTROL 2								
42.01	NBR OF AUX MOTORS	N/A	ONE	N/A	N/A			901	
42.02	AUX MOT START DLY	N/A	5.0 s	N/A	N/A			902	
42.03	AUX MOT STOP DLY	N/A	3.0 s	N/A	N/A			903	
42.04	INTERLOCKS	N/A	SET 1	N/A	N/A			904	
42.06	AUTOCHANGE INTERV	N/A	0 h 00 min	N/A	N/A			906	
42.07	AUTOCHANGE LEVEL	N/A	0.0 Hz	N/A	N/A			907	
42.08	FREQ TIME ON DLY	N/A	0.0 s	N/A	N/A			908	
42.09	FREQ TIME OFF DLY	N/A	0.0 s	N/A	N/A			909	
42.10	PFC START DELAY	N/A	500 ms	N/A	N/A			910	
42.11	REGUL BYPASS CTRL	N/A	NO	N/A	N/A			911	
43	SLEEP FUNCTION								
43.01	SLEEP SELECTION	INTERNAL	INTERNAL	N/A	N/A			926	
43.02	SLEEP DELAY	60.0 s	60.0 s	N/A	N/A			927	
43.03	SLEEP LEVEL	0.0 Hz	0.0 Hz	N/A	N/A			928	
43.04	WAKE UP SEL MODE	WAKE UP 1	WAKE UP 1	N/A	N/A			929	
43.05	WAKE UP LEVEL	0.0%	0.0%	N/A	N/A			930	
43.06	WAKE UP DELAY	0.0 s	0.0 s	N/A	N/A			931	
43.07	SLEEP BOOST STEP	0.0%	0.0%	N/A	N/A			932	
43.08	SLEEP BOOST TIME	0.0 s	0.0 s	N/A	N/A			933	
43.09	SLEEP1 SEL PTR	0	0	N/A	N/A			934	
43.10	SLEEP2 SEL PTR	0	0	N/A	N/A			935	
44	PFC PROTECTION								
44.01	INPUT PROT CTRL	NOT SEL	NOT SEL	NOT SEL	NOT SEL			951	
44.02	AI MEASURE INLET	NOT USED	NOT USED	NOT USED	NOT USED			952	
44.03	AI IN LOW LEVEL	0.0%	0.0%	0.0%	0.0%			953	
44.04	VERY LOW CTRL	NOT SEL	NOT SEL	NOT SEL	NOT SEL			954	

Index	Name/Selection	Default setting						PB	W
		MULTIMAS-TER	PFC TRAD	HAND/AUTO	LEVEL CTRL	USER 1	USER 2		
44.05	AI IN VERY LOW	0.0%	0.0%	0.0%	0.0%			955	
44.06	DI STATUS INLET	NOT USED	NOT USED	NOT USED	NOT USED			956	
44.07	INPUT CTRL DLY	0 s	0 s	0 s	0 s			957	
44.08	INLET FORCED REF	0%	0%	0%	0%			958	
44.09	OUTPUT PROT CTRL	NOT SEL	NOT SEL	NOT SEL	NOT SEL			959	
44.10	AI MEASURE OUTLET	NOT USED	NOT USED	NOT USED	NOT USED			960	
44.11	AI OUT HIGH LEVEL	0.0%	0.0%	0.0%	0.0%			961	
44.12	VERY HIGH CTRL	NOT SEL	NOT SEL	NOT SEL	NOT SEL			962	
44.13	AI OUT VERY HIGH	0%	0%	0%	0%			963	
44.14	DI STATUS OUTLET	NOT USED	NOT USED	NOT USED	NOT USED			964	
44.15	OUTPUT CTRL DLY	0 s	0 s	0 s	0 s			965	
44.16	OUTLET FORCED REF	0%	0%	0%	0%			966	
44.17	PI REF DEC TIME	1.00 s	1.00 s	1.00 s	1.00 s			967	
44.18	APPL PROFILE CTRL	APPL OUTPUT	APPL OUTPUT	APPL OUTPUT	APPL OUTPUT			968	
44.19	PROFILE OUTP LIM	100%	100%	100%	100%			969	
44.20	PROF LIMIT ON DLY	0.0 h	0.0 h	0.0 h	0.0 h			970	
44.21	PI REF FREEZE	NO	NO	NO	NO			971	
44.22	PI OUT FREEZE	NO	NO	NO	NO			972	
45	FLOWCONTROL								
45.01	FLOW MODE	OFF	OFF	OFF	OFF			976	
45.02	SUM FLOW RESET	OFF	OFF	OFF	OFF			977	
45.03	MAX INLET PRESSUR	0.00 bar	0.00 bar	0.00 bar	0.00 bar			978	
45.04	MAX OUTLET PRESSU	0.00 bar	0.00 bar	0.00 bar	0.00 bar			979	
45.07	Q1	0.0 m ³ /h	0.0 m ³ /h	0.0 m ³ /h	0.0 m ³ /h			982	
45.08	H1	0.0 m	0.0 m	0.0 m	0.0 m			983	
45.09	Q2	0.0 m ³ /h	0.0 m ³ /h	0.0 m ³ /h	0.0 m ³ /h			984	
45.10	H2	0.0 m	0.0 m	0.0 m	0.0 m			985	
45.11	Q3	0.0 m ³ /h	0.0 m ³ /h	0.0 m ³ /h	0.0 m ³ /h			986	
45.12	H3	0.0 m	0.0 m	0.0 m	0.0 m			987	
45.13	Q4	0.0 m ³ /h	0.0 m ³ /h	0.0 m ³ /h	0.0 m ³ /h			988	
45.14	H4	0.0 m	0.0 m	0.0 m	0.0 m			989	
45.15	Q5	0.0 m ³ /h	0.0 m ³ /h	0.0 m ³ /h	0.0 m ³ /h			990	
45.16	H5	0.0 m	0.0 m	0.0 m	0.0 m			991	
45.17	FLOW CALC MODE	Q-H CURVE	Q-H CURVE	Q-H CURVE	Q-H CURVE			992	
45.18	Q H Q KW BRKPOINT	0.00 m	0.00 m	0.00 m	0.00 m			993	
45.19	DENSITY	1000.0 kg/m ³	1000.0 kg/m ³	1000.0 kg/m ³	1000.0 kg/m ³			994	
45.20	PUMP KW1	0.0 kW	0.0 kW	0.0 kW	0.0 kW			995	
45.21	PUMP Q1	0.0 m ³ /h	0.0 m ³ /h	0.0 m ³ /h	0.0 m ³ /h			996	
45.22	PUMP KW2	0.0 kW	0.0 kW	0.0 kW	0.0 kW			997	
45.23	PUMP Q2	0.0 m ³ /h	0.0 m ³ /h	0.0 m ³ /h	0.0 m ³ /h			998	
45.24	PUMP KW3	0.0 kW	0.0 kW	0.0 kW	0.0 kW			999	
45.25	PUMP Q3	0.0 m ³ /h	0.0 m ³ /h	0.0 m ³ /h	0.0 m ³ /h			1000	
45.26	EFFICIENCY	100.0%	100.0%	100.0%	100.0%			-	
45.27	PUMP NOM SPEED	1500 rpm	1500 rpm	1500 rpm	1500 rpm			-	
45.28	PUMP INLET SEL	NOT SEL	NOT SEL	NOT SEL	NOT SEL			-	
45.29	PUMP OUTLET SEL	NOT SEL	NOT SEL	NOT SEL	NOT SEL			-	
45.30	FLOW CALC GAIN	1.00	1.00	1.00	1.00			-	
45.31	PUMP INLET DIAM	1.00 m	1.00 m	1.00 m	1.00 m			-	
45.32	PUMP OUTLET DIAM	1.00 m	1.00 m	1.00 m	1.00 m			-	

Additional data: actual signals and parameters

Index	Name/Selection	Default setting						PB	W
		MULTIMAS- TER	PFC TRAD	HAND/AUTO	LEVEL CTRL	USER 1	USER 2		
45.33	SENSOR HGT DIFF	0.00 m	0.00 m	0.00 m	0.00 m			-	
45.34	FLOW RESET PTR	0	0	0	0			-	
45.36	CALC LOW SPEED	0.00 Hz	0.00 Hz	0.00 Hz	0.00 Hz			-	
46	ANTI JAM								
46.01	A JAM ENABLE1	NOT SEL	NOT SEL	NOT SEL	NOT SEL			1001	
46.02	A JAM ENABLE MF	MASTER	N/A	N/A	MASTER			1002	
46.03	A JAM TRIGG MODE	NOT SEL	NOT SEL	NOT SEL	NOT SEL			1003	
46.04	A JAM FWDSTEPLEV	0.0%	0.0%	0.0%	0.0%			1004	
46.05	A JAM REVSTEPLEV	0.0%	0.0%	0.0%	0.0%			1005	
46.06	A JAM FWDSTEP TIM	0.00 s	0.00 s	0.00 s	0.00 s			1006	
46.07	A JAM REVSTEP TIM	0.00 s	0.00 s	0.00 s	0.00 s			1007	
46.08	A JAM STEP OFFTIM	0.00 s	0.00 s	0.00 s	0.00 s			1008	
46.09	A JAM I TRIGG LE	0.00 A	0.00 A	0.00 A	0.00 A			1009	
46.10	A JAM TIMETRIG LE	0.00 h	0.00 h	0.00 h	0.00 h			1010	
46.11	A JAM COUNT	0	0	0	0			1011	
46.12	A JAM ENB1 POINT	0	0	0	0			1012	
47	LEVEL CONTROL								
47.02	PUMP DIRECTION	N/A	N/A	N/A	EMPTYING				
47.03	CONTROL MODE	N/A	N/A	N/A	COMMON STOP				
47.04	LEVEL SOURCE SEL	N/A	N/A	N/A	AI2				
47.05	LOW LEVEL1	N/A	N/A	N/A	0.00%				
47.06	LOW LEVEL 2	N/A	N/A	N/A	NOT SEL				
47.07	STOP LEVEL	N/A	N/A	N/A	20.00%				
47.08	START1 LEVEL	N/A	N/A	N/A	40.00%				
47.09	START2 LEVEL	N/A	N/A	N/A	50.00%				
47.10	START3 LEVEL	N/A	N/A	N/A	60.00%				
47.11	START4 LEVEL	N/A	N/A	N/A	65.00%				
47.12	START5 LEVEL	N/A	N/A	N/A	70.00%				
47.13	START6 LEVEL	N/A	N/A	N/A	75.00%				
47.14	START7 LEVEL	N/A	N/A	N/A	80.00%				
47.15	START8 LEVEL	N/A	N/A	N/A	85.00%				
47.16	HIGH LEVEL1	N/A	N/A	N/A	90.00%				
47.17	HIGH LEVEL 2	N/A	N/A	N/A	NOT SEL				
47.18	LEVEL DELAY	N/A	N/A	N/A	1.00 s				
47.19	RANDOM COEF	N/A	N/A	N/A	0.00%				
47.20	EFFICIENCY SPEED	N/A	N/A	N/A	90.00%				
47.21	HIGH LEVEL SPEED	N/A	N/A	N/A	100.0%				
49	ENERGY OPT								
49.01	ENERGY TARIFF1	0.000 c/E	0.000 c/E	0.000 c/E	0.000 c/E			-	
49.02	E TARIFF UNIT	EUR	EUR	EUR	EUR			-	
49.03	PUMP REF POWER	100.00%	100.00%	100.00%	100.00%			-	
49.04	ENERGY RESET	DONE	DONE	DONE	DONE			-	
51	COMM MOD DATA							1026	
								...	
52	STANDARD MODBUS								
52.01	STATION NUMBER	1	1	1	1			1051	
52.02	BAUDRATE	9600	9600	9600	9600			1052	
52.03	PARITY	ODD	ODD	ODD	ODD			1053	
60	MASTER- FOLLOWER								
60.01	PUMP NODE	1	N/A	N/A	1			1195	
60.02	FOLLOWER MODE	AUTO	N/A	N/A	AUTO			1196	

Index	Name/Selection	Default setting						PB	W
		MULTIMAS-TER	PFC TRAD	HAND/AUTO	LEVEL CTRL	USER 1	USER 2		
60.03	FOLLOWER REF	50.0 Hz	N/A	N/A	N/A			1197	
60.04	AUTOCHANGE STYLE	NO	N/A	N/A	NO			1198	
60.05	AUTOCHANGE INTERV	3 min	N/A	N/A	3 min			1199	
60.07	NUM PUMPS ALLOWED	8	N/A	N/A	3			1201	
60.08	MASTER ENABLE	YES	N/A	N/A	YES			1202	
60.09	PUMP RUNTIME SEL	NO	N/A	N/A	NO			1203	
60.10	PUMP RUNTIME	0 h	N/A	N/A	0 h			1204	
60.11	PUMP RUNTIME DIFF	1 h	N/A	N/A	1 h			1205	
60.12	PUMP CLASS SEL	PAR CLASS1	N/A	N/A	PAR CLASS1			1206	
60.13	PUMP CLASS 1	1	N/A	N/A	1			1207	
60.14	PUMP CLASS 2	1	N/A	N/A	1			1208	
60.17	MASTER LOSS	LAST SPEED	N/A	N/A	LAST SPEED			1211	
60.18	F T M COMM LOSS	FOLL CTRL	N/A	N/A	FOLL CTRL			1212	
60.19	COMM DELAY	1.0 s	N/A	N/A	1.0 s			-	
60.20	ALL FOLL LOST	CONTINUE	N/A	N/A	CONTINUE			-	
60.21	MIN PUMP	0	N/A	N/A	0			-	
60.22	INV ORDER CORR	OPT CONTROL	N/A	N/A	OPT CONTROL			-	
60.23	RAMP ACCEL TIME	1.0 s	N/A	N/A	1.0 s			-	
60.24	RAMP DECEL TIME	1.0 s	N/A	N/A	1.0 s			-	
60.25	MASTER LOCATION	IN STARTED	N/A	N/A	IN STARTED			-	
65	SHARE IO								
65.01	SHARE IO ACTIVE	NO	NO	NO	NO			1285	
65.02	REPLACE IO	0000000	0000000	0000000	0000000			1286	
65.03	SECONDARY SOURCE	NO	NO	NO	NO			1287	
65.04	SHARE IO COM LOST	CONTINUE	CONTINUE	CONTINUE	CONTINUE			1288	
65.05	IO COM LOST DELAY	5.0 s	5.0 s	5.0 s	5.0 s			1289	
70	DDCS CONTROL								
70.01	CH0 NODE ADDR	1	1	1	1			1375	
70.02	CH3 NODE ADDR	1	1	1	1			1376	
70.03	CH2 HW CONNECTION	RING	RING	RING	RING			1377	
83	ADAPT PROG CNTRL								
83.01	ADAPT PROG CMD	EDIT	EDIT	EDIT	EDIT			1609	W
83.02	EDIT CMD	NO	NO	NO	NO			1610	
83.03	EDIT BLOCK	0	0	0	0			1611	
83.04	TIMELEV SEL	100 ms	100 ms	100 ms	100 ms			1612	
83.05	PASSCODE	0	0	0	0			1613	
84	ADAPTIVE PROGRAM								
84.01	STATUS	-	-	-	-			1628	
84.02	FAULTED PAR	0	0	0	0			1629	
84.05	BLOCK1	NO	NO	NO	NO			1630	
84.06	INPUT1	0	0	0	0			1631	
84.07	INPUT2	0	0	0	0			1632	
84.08	INPUT3	0	0	0	0			1633	
84.09	OUTPUT	0	0	0	0			1634	

Additional data: actual signals and parameters

Index	Name/Selection	Default setting						PB	W
		MULTIMAS- TER	PFC TRAD	HAND/AUTO	LEVEL CTRL	USER 1	USER 2		
...	
84.79	OUTPUT	0	0	0	0			1644	
85	USER CONSTANTS								
85.01	CONSTANT1	0	0	0	0			1645	
85.02	CONSTANT2	0	0	0	0			1646	
85.03	CONSTANT3	0	0	0	0			1647	
85.04	CONSTANT4	0	0	0	0			1648	
85.05	CONSTANT5	0	0	0	0			1649	
85.06	CONSTANT6	0	0	0	0			1650	
85.07	CONSTANT7	0	0	0	0			1651	
85.08	CONSTANT8	0	0	0	0			1652	
85.09	CONSTANT9	0	0	0	0			1653	
85.10	CONSTANT10	0	0	0	0			1654	
85.11	STRING1	MESSAGE1	MESSAGE1	MESSAGE1	MESSAGE1			1655	
85.12	STRING2	MESSAGE2	MESSAGE2	MESSAGE2	MESSAGE2			1656	
85.13	STRING3	MESSAGE3	MESSAGE3	MESSAGE3	MESSAGE3			1657	
85.14	STRING4	MESSAGE4	MESSAGE4	MESSAGE4	MESSAGE4			1658	
85.15	STRING5	MESSAGE5	MESSAGE5	MESSAGE5	MESSAGE5			1659	
90	D SET REC ADDR								
90.01	AUX DS REF3	0	0	0	0			1735	
90.02	AUX DS REF4	0	0	0	0			1736	
90.03	AUX DS REF5	0	0	0	0			1737	
90.04	MAIN DS SOURCE	1	1	1	1			1738	
90.05	AUX DS SOURCE	3	3	3	3			1739	
92	D SET TR ADDR								
92.01	MAIN DS STATUS WORD	302	302	302	302			1771	
92.02	MAIN DS ACT1	102	102	102	102			1772	
92.03	MAIN DS ACT2	105	105	105	105			1773	
92.04	AUX DS ACT3	305	305	305	305			1774	
92.05	AUX DS ACT4	308	308	308	308			1775	
92.06	AUX DS ACT5	306	306	306	306			1776	
95	HARDWARE SPECIFI								
95.06	LCU Q POW REF	0	0	0	0			1830	
95.07	LCU DC REF	0	0	0	0			1831	
95.08	LCU PAR1 SEL	106	106	106	106			1832	
95.09	LCU PAR2 SEL	110	110	110	110			1833	
96	ANALOGUE OUTPUTS								
96.01	EXT AO1 SEL	FREQUENCY	FREQUENCY	FREQUENCY	FREQUENCY			1843	
96.02	INVERT EXT AO1	NO	NO	NO	NO			1844	
96.03	MINIMUM EXT AO1	0 mA	0 mA	0 mA	0 mA			1845	
96.04	FILTER EXT AO1	0.10 s	0.10 s	0.10 s	0.10 s			1846	
96.05	SCALE EXT AO1	100%	100%	100%	100%			1847	
96.06	EXT AO2 SEL	CURRENT	CURRENT	CURRENT	CURRENT			1848	
96.07	INVERT EXT AO2	NO	NO	NO	NO			1849	
96.08	MINIMUM EXT AO2	0 mA	0 mA	0 mA	0 mA			1850	
96.09	FILTER EXT AO2	2.00 s	2.00 s	2.00 s	2.00 s			1851	
96.10	SCALE EXT AO2	100%	100%	100%	100%			1852	
96.11	EXT AO1 PTR	0	0	0	0			1853	
96.12	EXT AO2 PTR	0	0	0	0			1854	
98	OPTION MODULES								
98.02	COMM. MODULE LINK	NO	NO	NO	NO			1902	W
98.03	DI/O EXT MODULE 1	NO	NO	NO	NO			1903	W

Index	Name/Selection	Default setting						PB	W
		MULTIMAS- TER	PFC TRAD	HAND/AUTO	LEVEL CTRL	USER 1	USER 2		
98.04	DI/O EXT MODULE 2	NO	NO	NO	NO			1904	W
98.06	AI/O EXT MODULE	NO	NO	NO	NO			1906	W
98.07	COMM PROFILE	ABB DRIVES	ABB DRIVES	ABB DRIVES	ABB DRIVES			1907	W
98.08	AI/O EXT AI1 FUNC	UNIP AI5	UNIP AI5	UNIP AI5	UNIP AI5			1908	W
98.09	AI/O EXT AI2 FUNC	UNIP AI6	UNIP AI6	UNIP AI6	UNIP AI6			1909	W
99	START-UP DATA								
99.01	LANGUAGE	ENGLISH	ENGLISH	ENGLISH	ENGLISH			1926	W
99.02	APPLICATION MACRO	MULTIMAS- TER	PFC TRAD	HAND/AUTO	LEVEL CTRL			1927	W
99.03	APPLIC RESTORE	NO	NO	NO	NO			1928	W
99.04	MOTOR CTRL MODE	DTC	DTC	DTC	DTC			1929	W
99.05	MOTOR NOM VOLTAGE	0 V	0 V	0 V	0 V			1930	W
99.06	MOTOR NOM CURRENT	0.0 A	0.0 A	0.0 A	0.0 A			1931	W
99.07	MOTOR NOM FREQ	50.0 Hz	50.0 Hz	50.0 Hz	50.0 Hz			1932	W
99.08	MOTOR NOM SPEED	1 rpm	1 rpm	1 rpm	1 rpm			1933	W
99.09	MOTOR NOM POWER	0.0 kW	0.0 kW	0.0 kW	0.0 kW			1934	W
99.10	MOTOR ID RUN	NO	NO	NO	NO			1935	W
99.11	DEVICE NAME	-	-	-	-			1936	

Further information

Product and service inquiries

Address any inquiries about the product to your local ABB representative, quoting the type designation and serial number of the unit in question. A listing of ABB sales, support and service contacts can be found by navigating to www.abb.com/drives and selecting *Sales, Support and Service network*.

Product training

For information on ABB product training, navigate to www.abb.com/drives and select *Training courses*.

Providing feedback on ABB Drives manuals

Your comments on our manuals are welcome. Go to www.abb.com/drives and select *Document Library – Manuals feedback form (LV AC drives)*.

Document library on the Internet

You can find manuals and other product documents in PDF format on the Internet. Go to www.abb.com/drives and select *Document Library*. You can browse the library or enter selection criteria, for example a document code, in the search field.



3AFE68478952 REV C
EFFECTIVE: 2010-04-26 EN

ABB Oy
Drives
P.O. Box 184
FI-00381 HELSINKI
FINLAND
Telephone +358 10 22 11
Fax +358 10 22 22681
www.abb.com/drives

ABB Inc.
Automation Technologies
Drives & Motors
16250 West Glendale Drive
New Berlin, WI 53151
USA
Telephone 262 785-3200
1-800-HELP-365
Fax 262 780-5135
www.abb.com/drives

ABB Beijing Drive Systems Co. Ltd.
No. 1, Block D, A-10 Jiuxianqiao Beilu
Chaoyang District
Beijing, P.R. China, 100015
Telephone +86 10 5821 7788
Fax +86 10 5821 7618
www.abb.com/drives